



**Russell**<sup>®</sup>  
By Rheem

# MODEL: RAC(A/X)ZS iR Packaged Air Conditioner

FORM NO. SRR-992

## Russell<sup>®</sup> By Rheem Packaged Air Conditioner



### RAC(A/X)ZS

• Cooling Efficiencies: 15.2 SEER2



## TABLE OF CONTENTS

Unit Features & Benefits .....	3-4
Model Number Identification .....	5
Dimensional Data .....	6-9
Typical Installations .....	10
General Data .....	11-13
General Data Notes .....	14
Gross Systems Performance Data .....	15-18
Indoor Airflow Performance .....	19-24
Electrical Data .....	25-26
Electric Heater Kits .....	27-28
Accessories .....	29-41
Limited Warranty .....	44

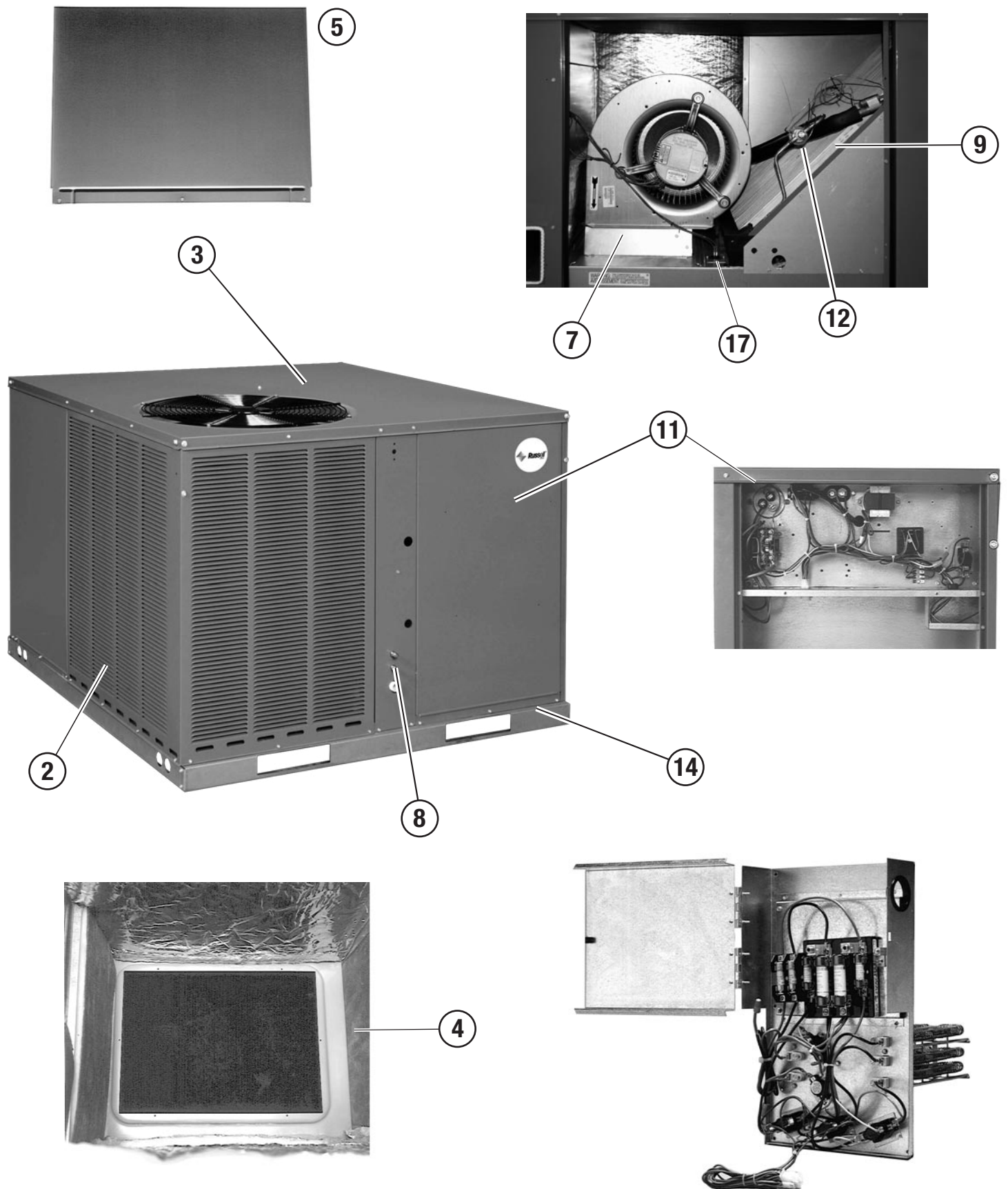

## FEATURES AND BENEFITS

1. The Two-Stage Compressor modulates between two capacity settings—67% and 100%—providing more precise temperature control, lower humidity and greater efficiency in comparison to single stage compressors. It uses 70% fewer moving parts which also increases efficiency and reliability.
2. Louvered condenser compartment to protect the coil against yard hazards and/or weather extremes.
3. One-piece top with a drip flange to help keep water out of the unit.
4. Drawn supply and return air openings feature a one-inch tall flange to prevent water migration into the ductwork.
5. Access panels have “weep holes” and channels to further help manage water run-off.
6. All models are shipped ready for horizontal application.
7. Easily accessible blower section complete with slide-out blower.
8. Refrigerant connections are conveniently located for easy service diagnostics.
9. Micro Channel evaporator and condenser delivers superior performance with less refrigerant charge and less weight than conventional copper tube/aluminum fin coils. In addition the all aluminum construction has superior protection against formicary corrosion and aluminum tube rubbing potential. It is easier to clean and has a more robust surface.
10. Supplemental electric heat strips up to 15 kW are available (field installed) for periods of extreme cold temperatures. Single point wiring simplifies installation.
11. Easily accessible control box.
12. Thermal expansion valve standard on all models for superior superheat control, reliability, and energy efficiency at all operating conditions.
13. Solid core liquid line. Filter drier standard on all models (not shown).
14. Rugged baserail included for improved installation and handling.
15. Molded compressor plug.
16. All units are complete factory charged and are factory quality run tested.
17. A double sloped evaporator coil drain pan assures all water is removed from the unit to improve indoor air quality.

## Packaged Air Conditioner

<u>R</u>	<u>AC</u>	<u>A</u>	<u>Z</u>	<u>S</u>	<u>036</u>	<u>A</u>	<u>J</u>	<u>T</u>	<u>000</u>	<u>N</u>	<u>A</u>
Brand	Product Category	Platform	Refrigerant	Tier	Capacity	Major Series	Voltage	Drive	Electric Heat Input	Control	Minor Series
R - Russell® By Rheem	AC - Air Conditioner	A - Resipack Convertible X - Resipack Convertible	Z - R410A	S - Mid Tier (EStar 15.2 SEER2)	024 - 24,000 [7.03 kW] 036 - 36,000 [10.55 kW] 048 - 48,000 [14.07 kW] 060 - 60,000 [17.58 kW]	A - 1st Design	J - 1ph, 208-230/60 C - 3ph, 208-230/60 D - 3ph, 460/60	T - Constant Torque	000 - No Electric Heat	N - Non-Communicating	A - 1st Design

[ ] Designates Metric Conversions

Available Models
RACAZS024AJT000NA
RACAZS036AJT000NA
RACAZS036ACT000NA
RACAZS036ADT000NA
RACXZS048AJT000NA
RACXZS048ACT000NA
RACXZS048ADT000NA
RACXZS060AJT000NA
RACXZS060ACT000NA
RACXZS060ADT000NA

**NOTE:** Heater kits available to purchase for field installation.

# UNIT DIMENSIONS PACKAGED AIR CONDITIONERS RACAZS

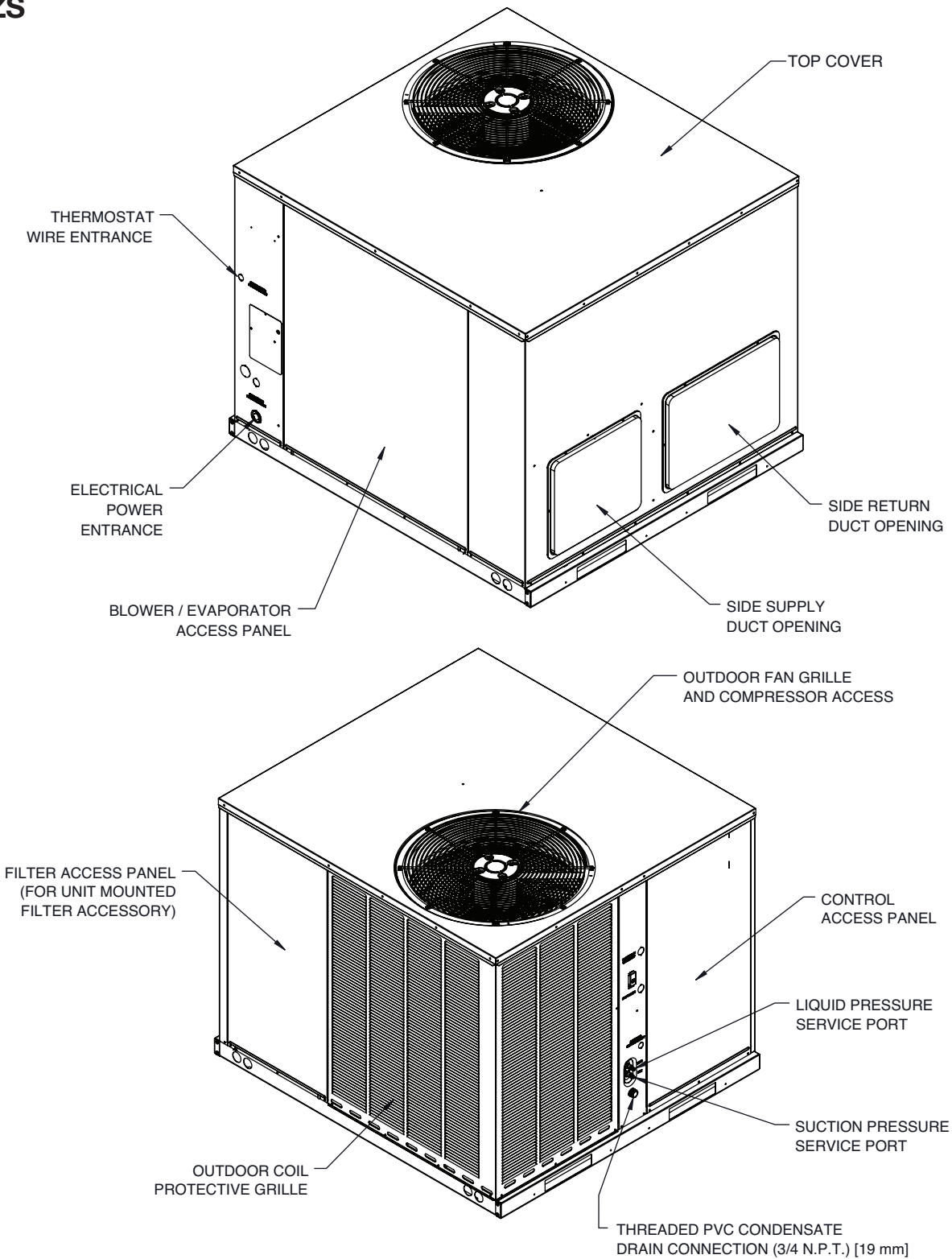
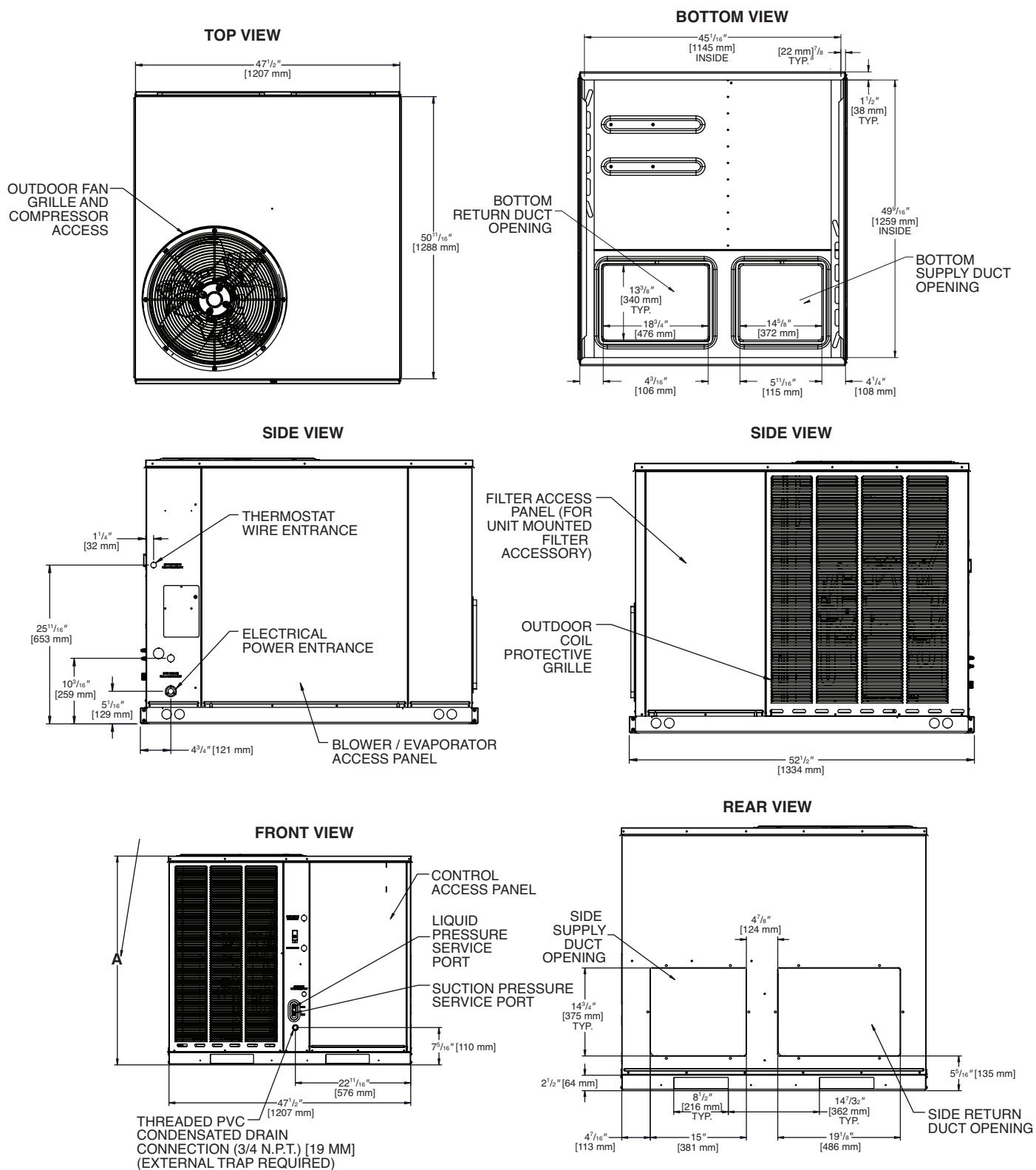

Illustration  
ST-A1333-01

[ ] Designates Metric Conversions

# RACAZS DIMENSIONAL DATA



[ ] Designates Metric Conversions

MODEL #	HEIGHT "A"
024	35-15/16
036	41

Illustration  
ST-A1333-02

# UNIT DIMENSIONS PACKAGED AIR CONDITIONERS RACXZS

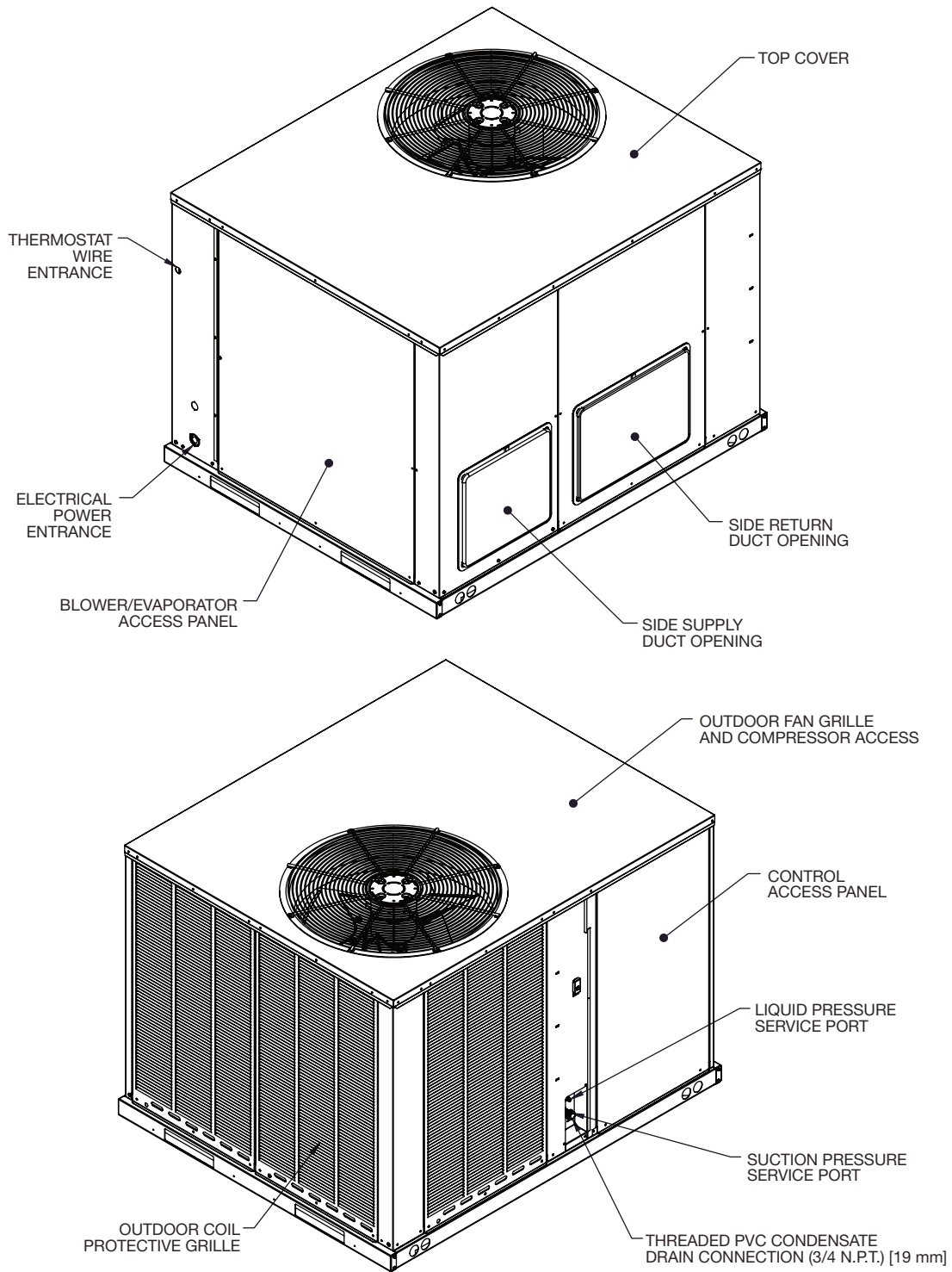

Illustration  
ST-A1334-01

[ ] Designates Metric Conversions



# UNIT DIMENSIONS

## PACKAGED AIR CONDITIONERS

### RACXZS

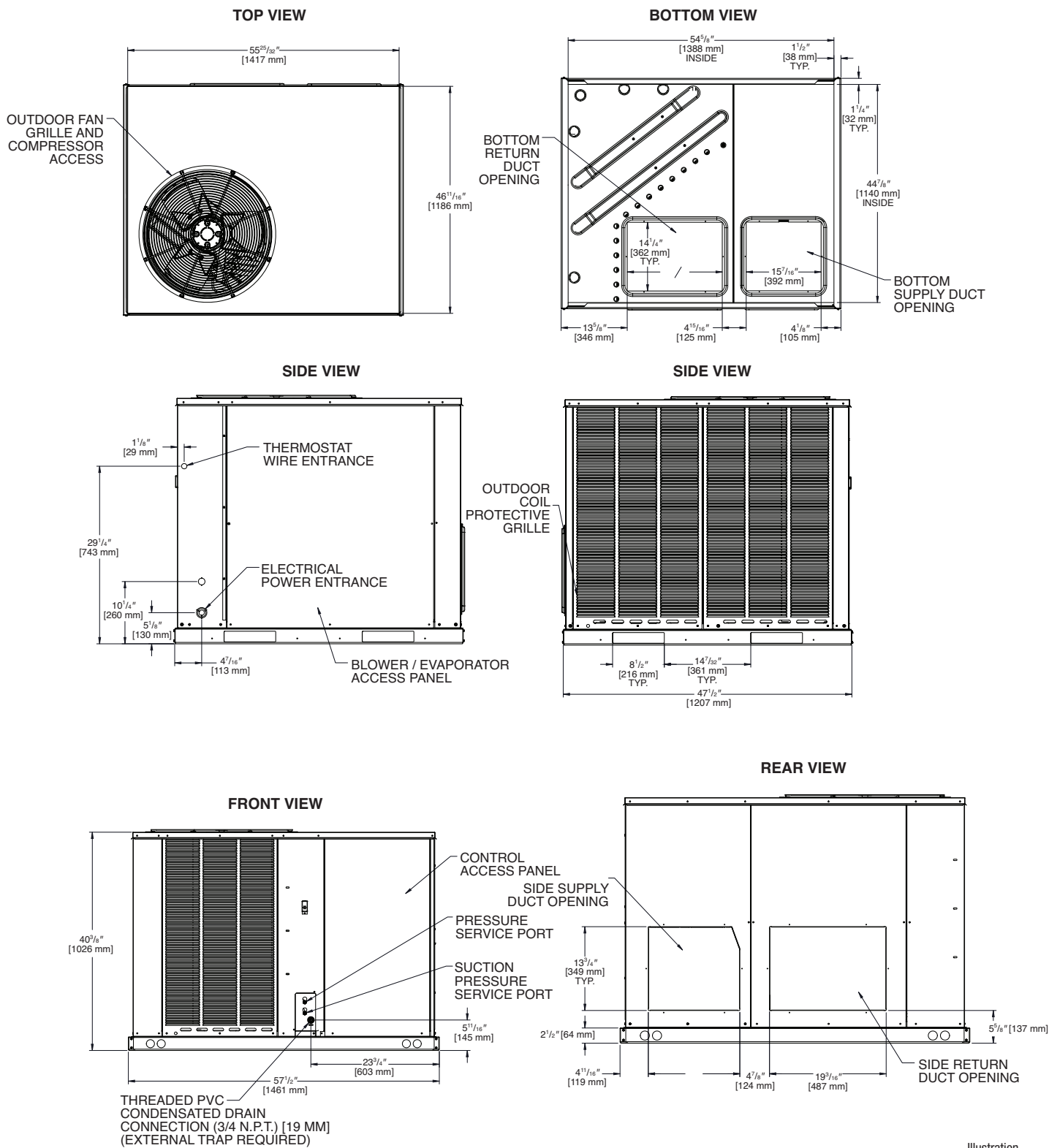
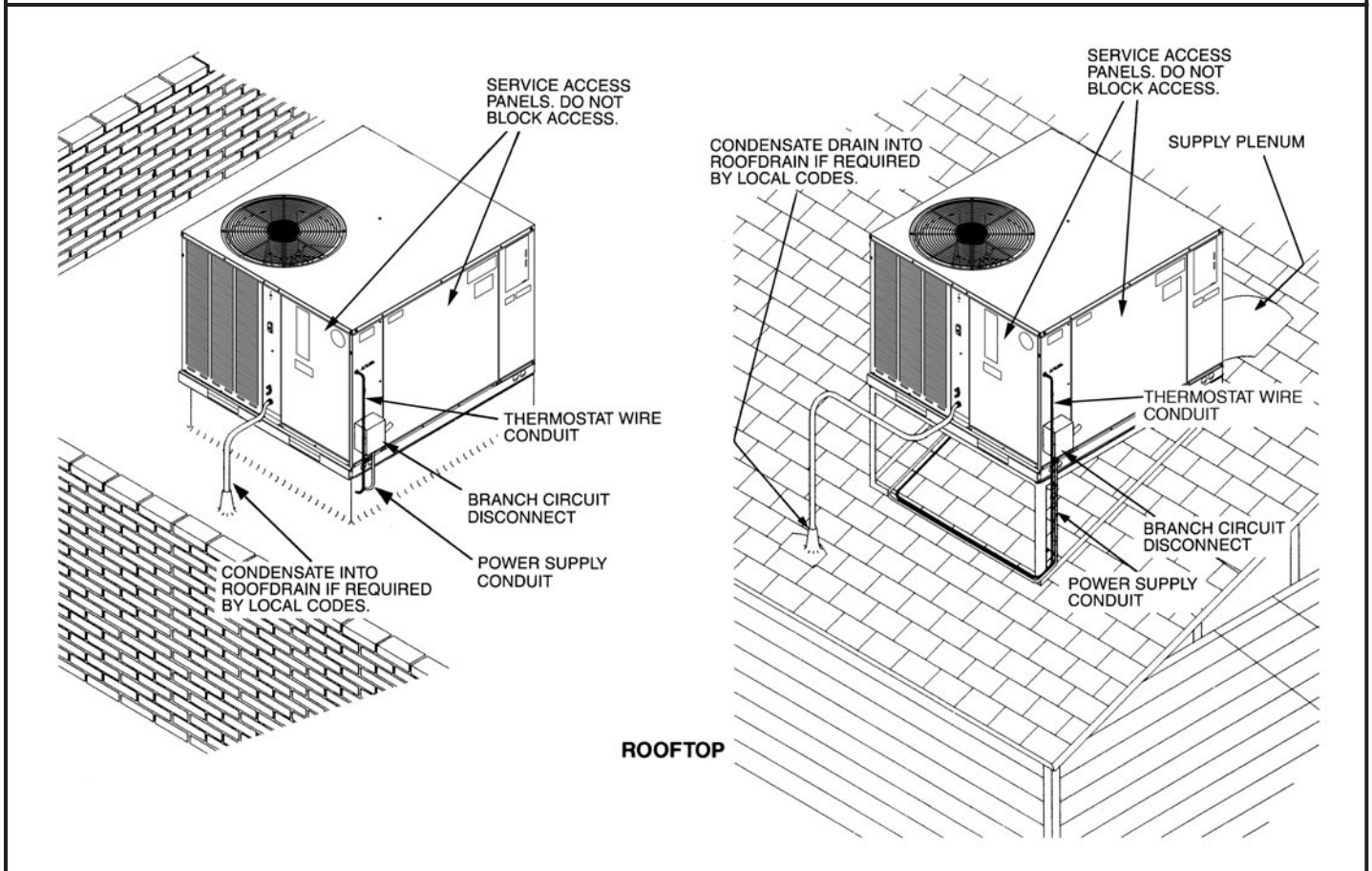
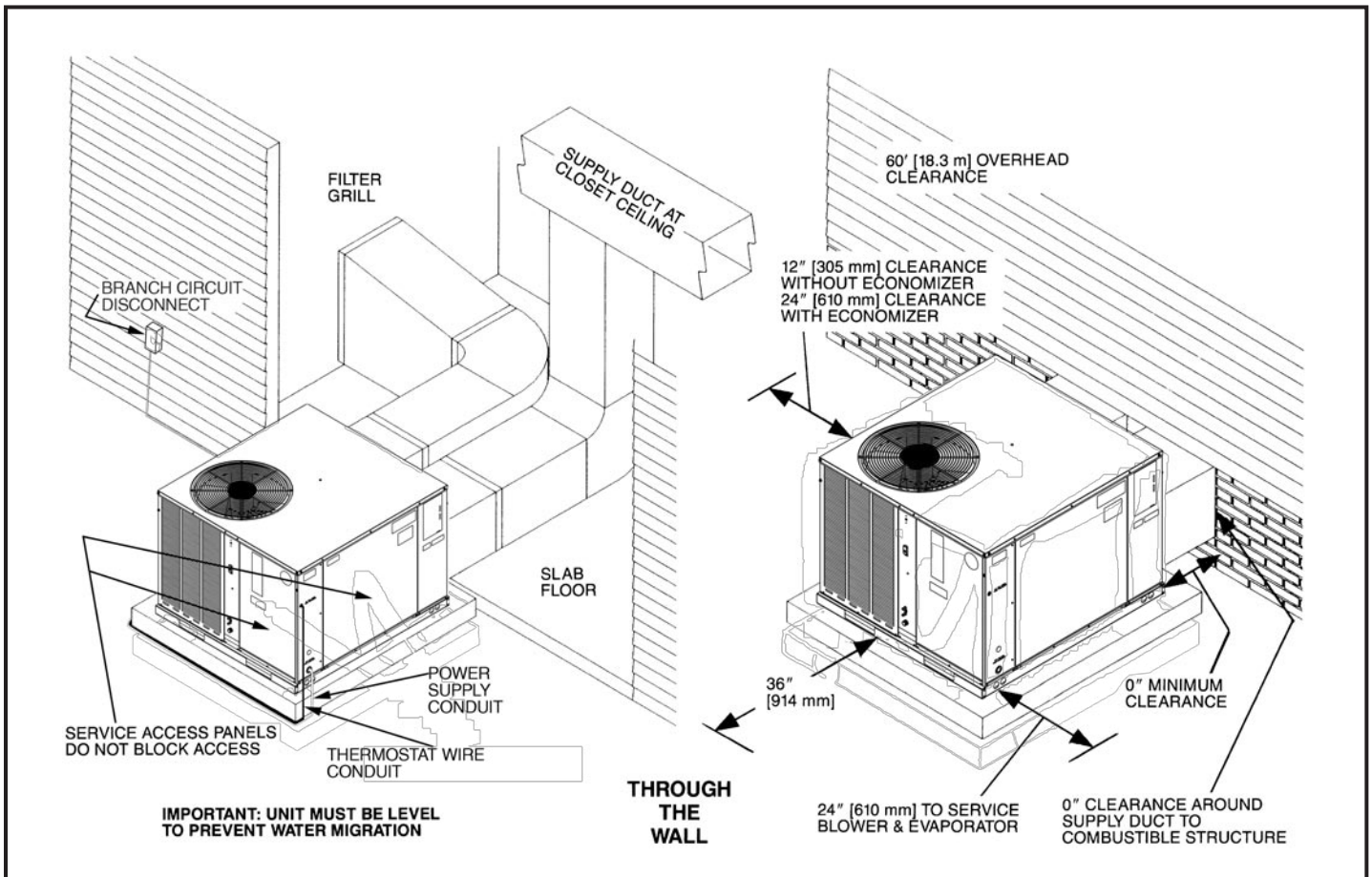

Illustration  
ST-A1334-02

[ ] Designates Metric Conversions



[ ] Designates Metric Conversions

## NOMINAL SIZES 2-5 TONS [7.0-17.6 kW]

Model RAC(A/X)ZS Series	024AJT	036ACT	036ADT	036AJT
<b>Cooling Performance<sup>1</sup></b>				<b>CONTINUED</b> →
Gross Cooling Capacity Btu [kW]	24,200 [7.09]	35,800 [10.49]	35,800 [10.49]	36,200 [10.61]
EER2/SEER2 <sup>2</sup>	11.5/15.2	12/16	12/16	11.5/15.2
Nominal CFM/AHRI Rated CFM [L/s]	800/815 [378/385]	1200/1200 [566/566]	1200/1200 [566/566]	1200/1200 [566/566]
AHRI Net Cooling Capacity Btu [kW]	23,400 [6.86]	35,000 [10.25]	35,000 [10.25]	35,000 [10.25]
Net Sensible Capacity Btu [kW]	16,600 [4.86]	25,800 [7.56]	25,800 [7.56]	25,800 [7.56]
Net Latent Capacity Btu [kW]	6,800 [1.99]	9,200 [2.7]	9,200 [2.7]	9,200 [2.7]
Net System Power kW	1.98	2.86	2.86	2.94
<b>Compressor</b>				
No./Type	1/Scroll	1/Scroll	1/Scroll	1/Scroll
<b>Outdoor Sound Rating (dB)<sup>3</sup></b>	74	71	71	71
<b>Outdoor Coil—Fin Type</b>	Louvered	Louvered	Louvered	Louvered
Tube Type	MicroChannel	MicroChannel	MicroChannel	MicroChannel
MicroChannel Depth in. [mm]	0.709 [18]	0.472 [12]	0.472 [12]	0.472 [12]
Face Area sq. ft. [sq. m]	9.77 [0.91]	16.26 [1.51]	16.26 [1.51]	16.26 [1.51]
Rows / FPI [FPcm]	1 / 23 [9]	1 / 23 [9]	1 / 23 [9]	1 / 23 [9]
<b>Indoor Coil—Fin Type</b>	Louvered	Louvered	Louvered	Louvered
Tube Type	MicroChannel	MicroChannel	MicroChannel	MicroChannel
MicroChannel Depth in. [mm]	1 [25.4]	1 [25.4]	1 [25.4]	1 [25.4]
Face Area sq. ft. [sq. m]	3.54 [0.33]	4 [0.37]	4 [0.37]	4 [0.37]
Rows / FPI [FPcm]	1 / 20 [8]	1 / 20 [8]	1 / 20 [8]	1 / 20 [8]
Refrigerant Control	TX Valves	TX Valves	TX Valves	TX Valves
Drain Connection No./Size in. [mm]	1/0.75 [19.05]	1/0.75 [19.05]	1/0.75 [19.05]	1/0.75 [19.05]
<b>Outdoor Fan—Type</b>	Propeller	Propeller	Propeller	Propeller
No. Used/Diameter in. [mm]	1/22 [558.8]	1/22 [558.8]	1/22 [558.8]	1/22 [558.8]
Drive Type/No. Speeds	Direct/1	Direct/1	Direct/1	Direct/1
CFM [L/s]	2500 [1180]	3250 [1534]	3250 [1534]	3250 [1534]
No. Motors/HP	1 at 1/6 HP	1 at 1/3 HP	1 at 1/3 HP	1 at 1/3 HP
Motor RPM	825	825	825	825
<b>Indoor Fan—Type</b>	FC Centrifugal	FC Centrifugal	FC Centrifugal	FC Centrifugal
No. Used/Diameter in. [mm]	1/10x9 [254x229]	1/12x9 [305x229]	1/12x9 [305x229]	1/12x9 [305x229]
Drive Type	Direct	Direct	Direct	Direct
No. Speeds	Multiple	Multiple	Multiple	Multiple
No. Motors	1	1	1	1
Motor HP	1/3	1	1	1
Motor RPM	1050	1050	1300	1050
Motor Frame Size	48	48	48	48
<b>Filter—Type</b>	Field Supplied	Field Supplied	Field Supplied	Field Supplied
Furnished	No	No	No	No
(NO.) Size Recommended in. [mm x mm x mm]	(1)1x24x24 [25x610x610]	(1)1x24x24 [25x610x610]	(1)1x24x24 [25x610x610]	(1)1x24x24 [25x610x610]
<b>Refrigerant Charge Oz. [g]</b>	48 [1361]	60 [1701]	60 [1701]	60 [1701]
<b>Weights</b>				
Net Weight lbs. [kg]	354 [161]	428 [194]	428 [194]	428 [194]
Ship Weight lbs. [kg]	362 [164]	436 [198]	436 [198]	436 [198]

See Page 14 for Notes.

[ ] Designates Metric Conversions

## NOMINAL SIZES 2-5 TONS [7.0-17.6 kW]

Model RAC(A/X)ZS Series	048ACT	048ADT	048AJT	060ACT
<b>Cooling Performance<sup>1</sup></b>				<b>CONTINUED</b> →
Gross Cooling Capacity Btu [kW]	48,500 [14.21]	48,500 [14.21]	49,000 [14.36]	59,000 [17.29]
EER2/SEER2 <sup>2</sup>	12/16	12/16	11.5/15.2	11.5/15.2
Nominal CFM/AHRI Rated CFM [L/s]	1600/1525 [755/720]	1600/1525 [755/720]	1600/1525 [755/720]	2000/1800 [944/849]
AHRI Net Cooling Capacity Btu [kW]	47,500 [13.92]	47,500 [13.92]	47,500 [13.92]	57,000 [16.7]
Net Sensible Capacity Btu [kW]	33,300 [9.76]	33,300 [9.76]	33,300 [9.76]	39,000 [11.43]
Net Latent Capacity Btu [kW]	14,200 [4.16]	14,200 [4.16]	14,200 [4.16]	18,000 [5.27]
Net System Power kW	3.84	3.84	3.94	4.82
<b>Compressor</b>				
No./Type	1/Scroll	1/Scroll	1/Scroll	1/Scroll
<b>Outdoor Sound Rating (dB)<sup>3</sup></b>	81	81	81	83
<b>Outdoor Coil—Fin Type</b>	Louvered	Louvered	Louvered	Louvered
Tube Type	MicroChannel	MicroChannel	MicroChannel	MicroChannel
MicroChannel Depth in. [mm]	1 [25.4]	1 [25.4]	1 [25.4]	1 [25.4]
Face Area sq. ft. [sq. m]	15.98 [1.48]	15.98 [1.48]	15.98 [1.48]	15.98 [1.48]
Rows / FPI [FPcm]	1 / 23 [9]	1 / 23 [9]	1 / 23 [9]	1 / 23 [9]
<b>Indoor Coil—Fin Type</b>	Louvered	Louvered	Louvered	Louvered
Tube Type	MicroChannel	MicroChannel	MicroChannel	MicroChannel
MicroChannel Depth in. [mm]	1 [25.4]	1 [25.4]	1 [25.4]	1.26 [32]
Face Area sq. ft. [sq. m]	7.07 [0.66]	7.07 [0.66]	7.07 [0.66]	6.96 [0.65]
Rows / FPI [FPcm]	1 / 20 [8]	1 / 20 [8]	1 / 20 [8]	1 / 20 [8]
Refrigerant Control	TX Valves	TX Valves	TX Valves	TX Valves
Drain Connection No./Size in. [mm]	1/0.75 [19.05]	1/0.75 [19.05]	1/0.75 [19.05]	1/0.75 [19.05]
<b>Outdoor Fan—Type</b>	Propeller	Propeller	Propeller	Propeller
No. Used/Diameter in. [mm]	1/24 [609.6]	1/24 [609.6]	1/24 [609.6]	1/24 [609.6]
Drive Type/No. Speeds	Direct/1	Direct/1	Direct/1	Direct/1
CFM [L/s]	4300 [2029]	4300 [2029]	4300 [2029]	4300 [2029]
No. Motors/HP	1 at 1/3 HP	1 at 1/3 HP	1 at 1/3 HP	1 at 1/3 HP
Motor RPM	1050	1050	1050	1050
<b>Indoor Fan—Type</b>	FC Centrifugal	FC Centrifugal	FC Centrifugal	FC Centrifugal
No. Used/Diameter in. [mm]	1/12x9 [305x229]	1/12x9 [305x229]	1/12x9 [305x229]	1/12x9 [305x229]
Drive Type	Direct	Direct	Direct	Direct
No. Speeds	Multiple	Multiple	Multiple	Multiple
No. Motors	1	1	1	1
Motor HP	1	1	1	1
Motor RPM	1050	1050	1050	1050
Motor Frame Size	48	48	48	48
<b>Filter—Type</b>	Field Supplied	Field Supplied	Field Supplied	Field Supplied
Furnished	No	No	No	No
(NO.) Size Recommended in. [mm x mm x mm]	(2)1x16x30 [25x406x762]	(2)1x16x30 [25x406x762]	(2)1x16x30 [25x406x762]	(2)1x16x30 [25x406x762]
<b>Refrigerant Charge Oz. [g]</b>	90 [2552]	90 [2552]	90 [2552]	100 [2835]
<b>Weights</b>				
Net Weight lbs. [kg]	455 [206]	455 [206]	455 [206]	460 [209]
Ship Weight lbs. [kg]	465 [211]	465 [211]	465 [211]	470 [213]

See Page 14 for Notes.

[ ] Designates Metric Conversions

## NOMINAL SIZES 2-5 TONS [7.0-17.6 kW]

Model RAC(A/X)ZS Series	060ADT	060AJT
<b>Cooling Performance<sup>1</sup></b>		
Gross Cooling Capacity Btu [kW]	59,000 [17.29]	59,000 [17.29]
EER2/SEER2 <sup>2</sup>	11.5/15.2	11.5/15.2
Nominal CFM/AHRI Rated CFM [L/s]	2000/1800 [944/849]	2000/1800 [944/849]
AHRI Net Cooling Capacity Btu [kW]	57,000 [16.7]	57,000 [16.7]
Net Sensible Capacity Btu [kW]	39,000 [11.43]	39,000 [11.43]
Net Latent Capacity Btu [kW]	18,000 [5.27]	18,000 [5.27]
Net System Power kW	4.82	5
<b>Compressor</b>		
No./Type	1/Scroll	1/Scroll
<b>Outdoor Sound Rating (dB)<sup>3</sup></b>		
	83	83
<b>Outdoor Coil—Fin Type</b>		
Tube Type	Louvered	Louvered
MicroChannel Depth in. [mm]	MicroChannel	MicroChannel
MicroChannel Depth in. [mm]	1 [25.4]	1 [25.4]
Face Area sq. ft. [sq. m]	15.98 [1.48]	15.98 [1.48]
Rows / FPI [FPcm]	1 / 23 [9]	1 / 23 [9]
<b>Indoor Coil—Fin Type</b>		
Tube Type	Louvered	Louvered
Tube Type	MicroChannel	MicroChannel
MicroChannel Depth in. [mm]	1.26 [32]	1.26 [32]
Face Area sq. ft. [sq. m]	6.96 [0.65]	6.96 [0.65]
Rows / FPI [FPcm]	1 / 20 [8]	1 / 20 [8]
Refrigerant Control	TX Valves	TX Valves
Drain Connection No./Size in. [mm]	1/0.75 [19.05]	1/0.75 [19.05]
<b>Outdoor Fan—Type</b>		
	Propeller	Propeller
No. Used/Diameter in. [mm]	1/24 [609.6]	1/24 [609.6]
Drive Type/No. Speeds	Direct/1	Direct/1
CFM [L/s]	4300 [2029]	4300 [2029]
No. Motors/HP	1 at 1/3 HP	1 at 1/3 HP
Motor RPM	1050	1050
<b>Indoor Fan—Type</b>		
	FC Centrifugal	FC Centrifugal
No. Used/Diameter in. [mm]	1/12x9 [305x229]	1/12x9 [305x229]
Drive Type	Direct	Direct
No. Speeds	Multiple	Multiple
No. Motors	1	1
Motor HP	1	1
Motor RPM	1050	1050
Motor Frame Size	48	48
<b>Filter—Type</b>		
	Field Supplied	Field Supplied
Furnished	No	No
(NO.) Size Recommended in. [mm x mm x mm]	(2)1x16x30 [25x406x762]	(2)1x16x30 [25x406x762]
<b>Refrigerant Charge Oz. [g]</b>		
	100 [2835]	100 [2835]
<b>Weights</b>		
Net Weight lbs. [kg]	460 [209]	460 [209]
Ship Weight lbs. [kg]	470 [213]	470 [213]

See Page 14 for Notes.

[ ] Designates Metric Conversions

**NOTES:**

1. Cooling Performance is rated at 95°F ambient, 80°F entering dry bulb, 67°F entering wet bulb. Gross capacity does not include the effect of blower motor heat. AHRI capacity is net and includes the effect of blower motor heat. Units are suitable for operation to  $\pm 20\%$  of nominal cfm. Units are certified in accordance with the Unitary Air Conditioner Equipment certification program, which is based on AHRI Standard 210/240 or 360.
2. EER2 and/or SEER2 are rated at AHRI conditions and in accordance with DOE test procedures.
3. Outdoor Sound Rating shown is tested in accordance with AHRI Standard 270.

**GROSS SYSTEMS PERFORMANCE DATA—RACA ZS024A**

ENTERING INDOOR AIR @ 80°F [26.7°C] dbE ①											
wbE		71°F [21.7°C]			67°F [19.4°C]			63°F [17.2°C]			
CFM [L/s]		900 [425]	825 [389]	650 [307]	900 [425]	825 [389]	650 [307]	900 [425]	825 [389]	650 [307]	
DR ①		.05	.09	.12	.05	.09	.12	.05	.09	.12	
OUTDOOR DRY BULB TEMPERATURE °F [°C]	75 [23.9]	Total BTUH [kW] Sens BTUH [kW] Power	28.7 [8.4] 16.1 [4.7] 1.7	28.2 [8.3] 15.5 [4.5] 1.7	27.1 [7.9] 13.9 [4.1] 1.6	27.1 [7.9] 19.4 [5.7] 1.7	26.6 [7.8] 18.6 [5.5] 1.7	25.6 [7.5] 16.7 [4.9] 1.6	25.7 [7.5] 23.4 [6.9] 1.7	25.3 [7.4] 22.4 [6.6] 1.6	24.3 [7.1] 20.2 [5.9] 1.6
	80 [26.7]	Total BTUH [kW] Sens BTUH [kW] Power	28.0 [8.2] 15.3 [4.5] 1.8	27.5 [8.1] 14.7 [4.3] 1.7	26.4 [7.7] 13.3 [3.9] 1.7	26.4 [7.7] 18.6 [5.5] 1.7	25.9 [7.6] 17.8 [5.2] 1.7	24.9 [7.3] 16.1 [4.7] 1.7	25.0 [7.3] 22.6 [6.6] 1.7	24.6 [7.2] 21.6 [6.3] 1.7	23.7 [6.9] 19.5 [5.7] 1.7
	85 [29.4]	Total BTUH [kW] Sens BTUH [kW] Power	27.2 [8.0] 14.7 [4.3] 1.8	26.8 [7.9] 14.1 [4.1] 1.8	25.8 [7.6] 12.7 [3.7] 1.8	25.6 [7.5] 17.9 [5.2] 1.8	25.2 [7.4] 17.2 [5.0] 1.8	24.2 [7.1] 15.5 [4.5] 1.8	24.3 [7.1] 21.9 [6.4] 1.8	23.9 [7.0] 21.0 [6.2] 1.8	23.0 [6.7] 18.9 [5.5] 1.8
	90 [32.2]	Total BTUH [kW] Sens BTUH [kW] Power	26.5 [7.8] 14.1 [4.1] 1.9	26.0 [7.6] 13.5 [4.0] 1.9	25.0 [7.3] 12.2 [3.6] 1.9	24.9 [7.3] 17.3 [5.1] 1.9	24.5 [7.2] 16.6 [4.9] 1.9	23.5 [6.9] 15.0 [4.4] 1.9	23.5 [6.9] 21.3 [6.2] 1.9	23.2 [6.8] 20.4 [6.0] 1.9	22.3 [6.5] 18.4 [5.4] 1.8
	95 [35]	Total BTUH [kW] Sens BTUH [kW] Power	25.7 [7.5] 13.6 [4.0] 2.0	25.3 [7.4] 13.1 [3.8] 2.0	24.3 [7.1] 11.8 [3.5] 2.0	24.1 [7.1] 16.9 [5.0] 2.0	23.7 [6.9] 16.2 [4.7] 2.0	22.8 [6.7] 14.6 [4.3] 1.9	22.8 [6.7] 20.8 [6.1] 2.0	22.4 [6.6] 20.0 [5.9] 2.0	21.5 [6.3] 18.0 [5.3] 1.9
	100 [37.8]	Total BTUH [kW] Sens BTUH [kW] Power	24.9 [7.3] 13.3 [3.9] 2.1	24.5 [7.2] 12.7 [3.7] 2.1	23.6 [6.9] 11.5 [3.4] 2.1	23.3 [6.8] 16.5 [4.8] 2.1	22.9 [6.7] 15.8 [4.6] 2.1	22.0 [6.4] 14.3 [4.2] 2.0	22.0 [6.4] 20.5 [6.0] 2.1	21.6 [6.3] 19.7 [5.8] 2.1	20.8 [6.1] 17.7 [5.2] 2.0
	105 [40.6]	Total BTUH [kW] Sens BTUH [kW] Power	24.1 [7.1] 13.0 [3.8] 2.2	23.7 [6.9] 12.5 [3.7] 2.2	22.8 [6.7] 11.3 [3.3] 2.2	22.5 [6.6] 16.3 [4.8] 2.2	22.1 [6.5] 15.6 [4.6] 2.2	21.3 [6.2] 14.1 [4.1] 2.2	21.2 [6.2] 20.2 [5.9] 2.2	20.8 [6.1] 19.4 [5.7] 2.2	20.0 [5.9] 17.5 [5.1] 2.1
	110 [43.3]	Total BTUH [kW] Sens BTUH [kW] Power	23.2 [6.8] 12.9 [3.8] 2.3	22.9 [6.7] 12.4 [3.6] 2.3	22.0 [6.4] 11.1 [3.3] 2.3	21.6 [6.3] 16.1 [4.7] 2.3	21.3 [6.2] 15.5 [4.5] 2.3	20.5 [6.0] 13.9 [4.1] 2.3	20.3 [5.9] 20.1 [5.9] 2.3	20.0 [5.9] 19.3 [5.7] 2.3	19.2 [5.6] 17.4 [5.1] 2.2
	115 [46.1]	Total BTUH [kW] Sens BTUH [kW] Power	22.4 [6.6] 12.9 [3.8] 2.5	22.0 [6.4] 12.3 [3.6] 2.4	21.2 [6.2] 11.1 [3.3] 2.4	20.8 [6.1] 16.1 [4.7] 2.4	20.4 [6.0] 15.4 [4.5] 2.4	19.6 [5.7] 13.9 [4.1] 2.4	19.4 [5.7] 19.4 [5.7] 2.4	19.1 [5.6] 19.1 [5.6] 2.4	18.4 [5.4] 17.4 [5.1] 2.4
	120 [48.9]	Total BTUH [kW] Sens BTUH [kW] Power	21.5 [6.3] 12.9 [3.8] 2.6	21.1 [6.2] 12.4 [3.6] 2.6	20.3 [5.9] 11.2 [3.3] 2.5	19.9 [5.8] 16.2 [4.7] 2.6	19.6 [5.7] 15.5 [4.5] 2.5	18.8 [5.5] 14.0 [4.1] 2.5	18.6 [5.5] 18.6 [5.5] 2.6	18.3 [5.4] 18.3 [5.4] 2.5	17.6 [5.2] 17.4 [5.1] 2.5
	125 [51.7]	Total BTUH [kW] Sens BTUH [kW] Power	20.6 [6.0] 13.1 [3.8] 2.7	20.2 [5.9] 12.6 [3.7] 2.7	19.5 [5.7] 11.3 [3.3] 2.6	19.0 [5.6] 16.4 [4.8] 2.7	18.7 [5.5] 15.7 [4.6] 2.7	17.9 [5.2] 14.1 [4.1] 2.6	17.6 [5.2] 17.6 [5.2] 2.7	17.4 [5.1] 17.4 [5.1] 2.7	16.7 [4.9] 16.7 [4.9] 2.6

DR —Depression ratio  
dbE —Entering air dry bulb  
wbE —Entering air wet bulb

Total —Total capacity x 1000 BTUH  
Sens —Sensible capacity x 1000 BTUH  
Power —KW input

NOTES: ① When the entering air dry bulb is other than 80°F [27°C], adjust the sensible capacity from the table by adding [1.10 x CFM x (1 - DR) x (dbE - 80)].

[ ] Designates Metric Conversions

## GROSS SYSTEMS PERFORMANCE DATA – RACA ZS036A

		ENTERING INDOOR AIR @ 80°F [26.7°C] dbE ①									
wbE		71°F [21.7°C]			67°F [19.4°C]			63°F [17.2°C]			
CFM [L/s]		1325 [625]	1200 [566]	950 [448]	1325 [625]	1200 [566]	950 [448]	1325 [625]	1200 [566]	950 [448]	
DR ①		.05	.09	.12	.05	.09	.12	.05	.09	.12	
COOLING DRY BULB TEMPERATURE °F [°C]	75 [23.9]	Total BTUH [kW] Sens BTUH [kW] Power	43.6 [12.8] 25.0 [7.3] 2.5	42.8 [12.5] 23.8 [7.0] 2.5	41.2 [12.1] 21.5 [6.3] 2.5	41.1 [12.0] 29.9 [8.8] 2.5	40.3 [11.8] 28.5 [8.4] 2.5	38.8 [11.4] 25.8 [7.6] 2.4	38.5 [11.3] 34.2 [10.0] 2.5	37.8 [11.1] 32.6 [9.6] 2.5	36.4 [10.7] 29.4 [8.6] 2.4
	80 [26.7]	Total BTUH [kW] Sens BTUH [kW] Power	42.4 [12.4] 24.3 [7.1] 2.6	41.6 [12.2] 23.1 [6.8] 2.6	40.0 [11.7] 20.9 [6.1] 2.6	39.8 [11.7] 29.2 [8.6] 2.6	39.1 [11.5] 27.8 [8.1] 2.6	37.6 [11.0] 25.1 [7.4] 2.5	37.3 [10.9] 33.5 [9.8] 2.6	36.6 [10.7] 31.9 [9.3] 2.6	35.2 [10.3] 28.8 [8.4] 2.5
	85 [29.4]	Total BTUH [kW] Sens BTUH [kW] Power	41.2 [12.1] 23.6 [6.9] 2.8	40.4 [11.8] 22.5 [6.6] 2.7	38.9 [11.4] 20.3 [5.9] 2.7	38.6 [11.3] 28.5 [8.4] 2.7	37.9 [11.1] 27.2 [8.0] 2.7	36.5 [10.7] 24.6 [7.2] 2.6	36.1 [10.6] 32.8 [9.6] 2.7	35.4 [10.4] 31.3 [9.2] 2.7	34.1 [10.0] 28.2 [8.3] 2.6
	90 [32.2]	Total BTUH [kW] Sens BTUH [kW] Power	39.9 [11.7] 23.0 [6.7] 2.9	39.2 [11.5] 21.9 [6.4] 2.8	37.7 [11.0] 19.8 [5.8] 2.8	37.4 [11.0] 27.9 [8.2] 2.8	36.7 [10.8] 26.6 [7.8] 2.8	35.3 [10.3] 24.0 [7.0] 2.8	34.9 [10.2] 32.2 [9.4] 2.8	34.2 [10.0] 30.7 [9.0] 2.8	32.9 [9.6] 27.7 [8.1] 2.7
	95 [35]	Total BTUH [kW] Sens BTUH [kW] Power	38.7 [11.3] 22.4 [6.6] 3.0	38.0 [11.1] 21.3 [6.2] 3.0	36.6 [10.7] 19.3 [5.7] 2.9	36.2 [10.6] 27.3 [8.0] 3.0	35.5 [10.4] 26.0 [7.6] 2.9	34.2 [10.0] 23.5 [6.9] 2.9	33.6 [9.8] 31.6 [9.3] 2.9	33.0 [9.7] 30.1 [8.8] 2.9	31.8 [9.3] 27.2 [8.0] 2.9
	100 [37.8]	Total BTUH [kW] Sens BTUH [kW] Power	37.5 [11.0] 21.8 [6.4] 3.1	36.8 [10.8] 20.8 [6.1] 3.1	35.4 [10.4] 18.8 [5.5] 3.1	35.0 [10.3] 26.8 [7.9] 3.1	34.3 [10.1] 25.5 [7.5] 3.1	33.0 [9.7] 23.0 [6.7] 3.0	32.4 [9.5] 31.0 [9.1] 3.1	31.8 [9.3] 29.6 [8.7] 3.1	30.6 [9.0] 26.7 [7.8] 3.0
	105 [40.6]	Total BTUH [kW] Sens BTUH [kW] Power	36.3 [10.6] 21.3 [6.2] 3.3	35.6 [10.4] 20.3 [5.9] 3.3	34.3 [10.1] 18.3 [5.4] 3.2	33.7 [9.9] 26.2 [7.7] 3.3	33.1 [9.7] 25.0 [7.3] 3.2	31.9 [9.3] 22.6 [6.6] 3.2	31.2 [9.1] 30.5 [8.9] 3.2	30.6 [9.0] 29.1 [8.5] 3.2	29.5 [8.6] 26.3 [7.7] 3.1
	110 [43.3]	Total BTUH [kW] Sens BTUH [kW] Power	35.1 [10.3] 20.8 [6.1] 3.4	34.4 [10.1] 19.9 [5.8] 3.4	33.1 [9.7] 17.9 [5.2] 3.3	32.5 [9.5] 25.8 [7.6] 3.4	31.9 [9.3] 24.6 [7.2] 3.4	30.7 [9.0] 22.2 [6.5] 3.3	30.0 [8.8] 30.0 [8.8] 3.4	29.4 [8.6] 28.6 [8.4] 3.4	28.3 [8.3] 25.9 [7.6] 3.3
	115 [46.1]	Total BTUH [kW] Sens BTUH [kW] Power	33.8 [9.9] 20.4 [6.0] 3.6	33.2 [9.7] 19.5 [5.7] 3.6	32.0 [9.4] 17.6 [5.2] 3.5	31.3 [9.2] 25.3 [7.4] 3.6	30.7 [9.0] 24.2 [7.1] 3.5	29.6 [8.7] 21.8 [6.4] 3.5	28.8 [8.4] 28.8 [8.4] 3.6	28.2 [8.3] 28.2 [8.3] 3.5	27.2 [8.0] 25.5 [7.5] 3.5
	120 [48.9]	Total BTUH [kW] Sens BTUH [kW] Power	32.6 [9.6] 20.0 [5.9] 3.8	32.0 [9.4] 19.1 [5.6] 3.7	30.8 [9.0] 17.2 [5.0] 3.7	30.1 [8.8] 24.9 [7.3] 3.8	29.5 [8.6] 23.8 [7.0] 3.7	28.4 [8.3] 21.5 [6.3] 3.7	27.5 [8.1] 27.5 [8.1] 3.7	27.0 [7.9] 27.0 [7.9] 3.7	26.0 [7.6] 25.1 [7.4] 3.6
	125 [51.7]	Total BTUH [kW] Sens BTUH [kW] Power	31.4 [9.2] 19.7 [5.8] 4.0	30.8 [9.0] 18.7 [5.5] 3.9	29.7 [8.7] 16.9 [5.0] 3.9	28.9 [8.5] 24.6 [7.2] 3.9	28.3 [8.3] 23.4 [6.9] 3.9	27.3 [8.0] 21.2 [6.2] 3.8	26.3 [7.7] 26.3 [7.7] 3.9	25.8 [7.6] 25.8 [7.6] 3.9	24.9 [7.3] 24.8 [7.3] 3.8

DR —Depression ratio  
dbE —Entering air dry bulb  
wbE —Entering air wet bulb

Total —Total capacity x 1000 BTUH  
Sens —Sensible capacity x 1000 BTUH  
Power —KW input

NOTES: ① When the entering air dry bulb is other than 80°F [27°C], adjust the sensible capacity from the table by adding [1.10 x CFM x (1 - DR) x (dbE - 80)].

[ ] Designates Metric Conversions



**GROSS SYSTEMS PERFORMANCE DATA—RACXZS048A**

ENTERING INDOOR AIR @ 80°F [26.7°C] dbE ①											
wbE		71°F [21.7°C]			67°F [19.4°C]			63°F [17.2°C]			
CFM [L/s]		1850 [873]	1800 [850]	1325 [625]	1850 [873]	1800 [850]	1325 [625]	1850 [873]	1800 [850]	1325 [625]	
DR ①		.05	.09	.12	.05	.09	.12	.05	.09	.12	
OUTDOOR DRY BULB TEMPERATURE °F [°C]	75 [23.9]	Total BTUH [kW] Sens BTUH [kW] Power	59.5 [17.4] 32.5 [9.5] 3.5	59.2 [17.4] 32.1 [9.4] 3.5	56.3 [16.5] 28.2 [8.3] 3.4	55.4 [16.2] 37.8 [11.1] 3.4	55.1 [16.1] 37.4 [11.0] 3.4	52.4 [15.4] 32.8 [9.6] 3.4	51.5 [15.1] 42.6 [12.5] 3.4	51.2 [15.0] 42.1 [12.3] 3.4	48.8 [14.3] 36.9 [10.8] 3.3
	80 [26.7]	Total BTUH [kW] Sens BTUH [kW] Power	58.1 [17.0] 32.0 [9.4] 3.6	57.8 [16.9] 31.6 [9.3] 3.6	55.0 [16.1] 27.7 [8.1] 3.5	54.0 [15.8] 37.3 [10.9] 3.6	53.7 [15.7] 36.8 [10.8] 3.6	51.1 [15.0] 32.3 [9.5] 3.5	50.1 [14.7] 42.0 [12.3] 3.5	49.8 [14.6] 41.5 [12.2] 3.5	47.4 [13.9] 36.4 [10.7] 3.4
	85 [29.4]	Total BTUH [kW] Sens BTUH [kW] Power	56.6 [16.6] 31.3 [9.2] 3.7	56.3 [16.5] 30.9 [9.1] 3.7	53.6 [15.7] 27.1 [7.9] 3.6	52.5 [15.4] 36.6 [10.7] 3.7	52.3 [15.3] 36.2 [10.6] 3.7	49.8 [14.6] 31.7 [9.3] 3.6	48.6 [14.2] 41.4 [12.1] 3.7	48.4 [14.2] 40.8 [12.0] 3.6	46.1 [13.5] 35.8 [10.5] 3.6
	90 [32.2]	Total BTUH [kW] Sens BTUH [kW] Power	55.1 [16.1] 30.6 [9.0] 3.9	54.8 [16.1] 30.2 [8.9] 3.9	52.2 [15.3] 26.5 [7.8] 3.8	51.0 [14.9] 35.9 [10.5] 3.8	50.8 [14.9] 35.4 [10.4] 3.8	48.3 [14.2] 31.1 [9.1] 3.7	47.1 [13.8] 40.7 [11.9] 3.8	46.9 [13.7] 40.1 [11.8] 3.8	44.7 [13.1] 35.2 [10.3] 3.7
	95 [35]	Total BTUH [kW] Sens BTUH [kW] Power	53.6 [15.7] 29.8 [8.7] 4.0	53.3 [15.6] 29.4 [8.6] 4.0	50.7 [14.9] 25.8 [7.6] 3.9	49.5 [14.5] 35.1 [10.3] 4.0	49.2 [14.4] 34.7 [10.2] 4.0	46.9 [13.7] 30.4 [8.9] 3.9	45.6 [13.4] 39.9 [11.7] 4.0	45.4 [13.3] 39.4 [11.5] 4.0	43.2 [12.7] 34.5 [10.1] 3.9
	100 [37.8]	Total BTUH [kW] Sens BTUH [kW] Power	52.0 [15.2] 29.0 [8.5] 4.2	51.7 [15.2] 28.6 [8.4] 4.2	49.2 [14.4] 25.1 [7.4] 4.1	47.9 [14.0] 34.3 [10.1] 4.2	47.6 [14.0] 33.8 [9.9] 4.2	45.3 [13.3] 29.7 [8.7] 4.1	44.0 [12.9] 39.0 [11.4] 4.1	43.8 [12.8] 38.5 [11.3] 4.1	41.7 [12.2] 33.8 [9.9] 4.0
	105 [40.6]	Total BTUH [kW] Sens BTUH [kW] Power	50.3 [14.7] 28.1 [8.2] 4.4	50.0 [14.7] 27.7 [8.1] 4.4	47.6 [14.0] 24.3 [7.1] 4.3	46.2 [13.5] 33.3 [9.8] 4.4	46.0 [13.5] 32.9 [9.6] 4.4	43.8 [12.8] 28.9 [8.5] 4.3	42.3 [12.4] 38.1 [11.2] 4.3	42.1 [12.3] 37.6 [11.0] 4.3	40.1 [11.8] 33.0 [9.7] 4.2
	110 [43.3]	Total BTUH [kW] Sens BTUH [kW] Power	48.6 [14.2] 27.1 [7.9] 4.6	48.3 [14.2] 26.7 [7.8] 4.6	46.0 [13.5] 23.4 [6.9] 4.5	44.5 [13.0] 32.4 [9.5] 4.6	44.3 [13.0] 31.9 [9.3] 4.6	42.2 [12.4] 28.0 [8.2] 4.5	40.6 [11.9] 37.1 [10.9] 4.5	40.4 [11.8] 36.6 [10.7] 4.5	38.5 [11.3] 32.1 [9.4] 4.4
	115 [46.1]	Total BTUH [kW] Sens BTUH [kW] Power	46.8 [13.7] 26.0 [7.6] 4.8	46.6 [13.7] 25.7 [7.5] 4.8	44.4 [13.0] 22.5 [6.6] 4.7	42.7 [12.5] 31.3 [9.2] 4.8	42.5 [12.5] 30.9 [9.1] 4.8	40.5 [11.9] 27.1 [7.9] 4.7	38.9 [11.4] 36.1 [10.6] 4.7	38.7 [11.3] 35.6 [10.4] 4.7	36.8 [10.8] 31.2 [9.1] 4.6
	120 [48.9]	Total BTUH [kW] Sens BTUH [kW] Power	45.0 [13.2] 24.9 [7.3] 5.1	44.8 [13.1] 24.6 [7.2] 5.1	42.6 [12.5] 21.5 [6.3] 4.9	40.9 [12.0] 30.2 [8.9] 5.0	40.7 [11.9] 29.8 [8.7] 5.0	38.8 [11.4] 26.1 [7.6] 4.9	37.0 [10.8] 34.9 [10.2] 5.0	36.8 [10.8] 34.5 [10.1] 5.0	35.1 [10.3] 30.2 [8.9] 4.9
	125 [51.7]	Total BTUH [kW] Sens BTUH [kW] Power	43.1 [12.6] 23.7 [6.9] 5.3	42.9 [12.6] 23.4 [6.9] 5.3	40.9 [12.0] 20.5 [6.0] 5.2	39.0 [11.4] 29.0 [8.5] 5.3	38.8 [11.4] 28.6 [8.4] 5.3	37.0 [10.8] 25.1 [7.4] 5.1	35.2 [10.3] 33.7 [9.9] 5.2	35.0 [10.3] 33.3 [9.8] 5.2	33.3 [9.8] 29.2 [8.6] 5.1

DR —Depression ratio  
dbE —Entering air dry bulb  
wbE—Entering air wet bulb

Total —Total capacity x 1000 BTUH  
Sens —Sensible capacity x 1000 BTUH  
Power —KW input

NOTES: ① When the entering air dry bulb is other than 80°F [27°C], adjust the sensible capacity from the table by adding  $[1.10 \times \text{CFM} \times (1 - \text{DR}) \times (\text{dbE} - 80)]$ .

[ ] Designates Metric Conversions

### GROSS SYSTEMS PERFORMANCE DATA – RACAXZS060A

		ENTERING INDOOR AIR @ 80°F [26.7°C] dbE ①									
wbE		71°F [21.7°C]			67°F [19.4°C]			63°F [17.2°C]			
CFM [L/s]		2150 [1015]	1800 [850]	1550 [732]	2150 [1015]	1800 [850]	1550 [732]	2150 [1015]	1800 [850]	1550 [732]	
DR ①		.05	.09	.12	.05	.09	.12	.05	.09	.12	
OUTDOOR DRY BULB TEMPERATURE °F [°C]	75 [23.9]	Total BTUH [kW] Sens BTUH [kW] Power	71.4 [20.9] 40.3 [11.8] 4.3	69.0 [20.2] 37.0 [10.8] 4.2	67.2 [19.7] 34.6 [10.1] 4.2	66.7 [19.5] 46.2 [13.5] 4.2	64.4 [18.9] 42.4 [12.4] 4.2	62.8 [18.4] 39.6 [11.6] 4.1	62.0 [18.2] 52.1 [15.3] 4.2	59.9 [17.6] 47.8 [14.0] 4.1	58.4 [17.1] 44.7 [13.1] 4.0
	80 [26.7]	Total BTUH [kW] Sens BTUH [kW] Power	69.7 [20.4] 39.6 [11.6] 4.5	67.3 [19.7] 36.3 [10.6] 4.4	65.6 [19.2] 33.9 [9.9] 4.3	65.0 [19.1] 45.5 [13.3] 4.4	62.7 [18.4] 41.7 [12.2] 4.3	61.2 [17.9] 39.0 [11.4] 4.3	60.3 [17.7] 51.4 [15.1] 4.3	58.2 [17.1] 47.1 [13.8] 4.3	56.7 [16.6] 44.0 [12.9] 4.2
	85 [29.4]	Total BTUH [kW] Sens BTUH [kW] Power	67.9 [19.9] 38.8 [11.4] 4.7	65.6 [19.2] 35.6 [10.4] 4.6	63.9 [18.7] 33.3 [9.8] 4.5	63.2 [18.5] 44.7 [13.1] 4.6	61.0 [17.9] 41.0 [12.0] 4.5	59.5 [17.4] 38.3 [11.2] 4.5	58.5 [17.1] 50.6 [14.8] 4.5	56.5 [16.6] 46.4 [13.6] 4.4	55.1 [16.1] 43.4 [12.7] 4.4
	90 [32.2]	Total BTUH [kW] Sens BTUH [kW] Power	66.1 [19.4] 38.1 [11.2] 4.9	63.9 [18.7] 34.9 [10.2] 4.8	62.3 [18.3] 32.6 [9.6] 4.7	61.4 [18.0] 44.0 [12.9] 4.8	59.3 [17.4] 40.3 [11.8] 4.7	57.8 [16.9] 37.7 [11.0] 4.6	56.7 [16.6] 49.8 [14.6] 4.7	54.8 [16.1] 45.7 [13.4] 4.6	53.4 [15.7] 42.7 [12.5] 4.6
	95 [35]	Total BTUH [kW] Sens BTUH [kW] Power	64.4 [18.9] 37.3 [10.9] 5.1	62.2 [18.2] 34.2 [10.0] 5.0	60.6 [17.8] 32.0 [9.4] 4.9	59.7 [17.5] 43.2 [12.7] 5.0	57.6 [16.9] 39.6 [11.6] 4.9	56.2 [16.5] 37.0 [10.8] 4.9	55.0 [16.1] 49.1 [14.4] 4.9	53.1 [15.6] 45.0 [13.2] 4.8	51.8 [15.2] 42.1 [12.3] 4.8
	100 [37.8]	Total BTUH [kW] Sens BTUH [kW] Power	62.6 [18.3] 36.6 [10.7] 5.3	60.5 [17.7] 33.5 [9.8] 5.2	58.9 [17.3] 31.3 [9.2] 5.1	57.9 [17.0] 42.4 [12.4] 5.2	55.9 [16.4] 38.9 [11.4] 5.1	54.5 [16.0] 36.4 [10.7] 5.1	53.2 [15.6] 48.3 [14.2] 5.2	51.4 [15.1] 44.3 [13.0] 5.1	50.1 [14.7] 41.4 [12.1] 5.0
	105 [40.6]	Total BTUH [kW] Sens BTUH [kW] Power	60.8 [17.8] 35.8 [10.5] 5.5	58.8 [17.2] 32.8 [9.6] 5.4	57.3 [16.8] 30.7 [9.0] 5.4	56.1 [16.4] 41.7 [12.2] 5.5	54.2 [15.9] 38.2 [11.2] 5.4	52.9 [15.5] 35.7 [10.5] 5.3	51.4 [15.1] 47.6 [14.0] 5.4	49.7 [14.6] 43.6 [12.8] 5.3	48.4 [14.2] 40.8 [12.0] 5.2
	110 [43.3]	Total BTUH [kW] Sens BTUH [kW] Power	59.1 [17.3] 35.0 [10.3] 5.8	57.1 [16.7] 32.1 [9.4] 5.7	55.6 [16.3] 30.0 [8.8] 5.6	54.4 [15.9] 40.9 [12.0] 5.7	52.5 [15.4] 37.5 [11.0] 5.6	51.2 [15.0] 35.1 [10.3] 5.6	49.7 [14.6] 46.8 [13.7] 5.7	48.0 [14.1] 42.9 [12.6] 5.6	46.8 [13.7] 40.1 [11.8] 5.5
	115 [46.1]	Total BTUH [kW] Sens BTUH [kW] Power	57.3 [16.8] 34.3 [10.1] 6.1	55.4 [16.2] 31.4 [9.2] 6.0	54.0 [15.8] 29.4 [8.6] 5.9	52.6 [15.4] 40.2 [11.8] 6.0	50.8 [14.9] 36.8 [10.8] 5.9	49.5 [14.5] 34.4 [10.1] 5.8	47.9 [14.0] 46.1 [13.5] 5.9	46.3 [13.6] 42.2 [12.4] 5.8	45.1 [13.2] 39.5 [11.6] 5.8
	120 [48.9]	Total BTUH [kW] Sens BTUH [kW] Power	55.5 [16.3] 33.5 [9.8] 6.4	53.7 [15.7] 30.7 [9.0] 6.3	52.3 [15.3] 28.7 [8.4] 6.2	50.9 [14.9] 39.4 [11.5] 6.3	49.1 [14.4] 36.1 [10.6] 6.2	47.9 [14.0] 33.8 [9.9] 6.1	46.2 [13.5] 45.3 [13.3] 6.2	44.6 [13.1] 41.5 [12.2] 6.1	43.5 [12.7] 38.8 [11.4] 6.1
	125 [51.7]	Total BTUH [kW] Sens BTUH [kW] Power	53.8 [15.8] 32.8 [9.6] 6.7	51.9 [15.2] 30.0 [8.8] 6.6	50.6 [14.8] 28.1 [8.2] 6.5	49.1 [14.4] 38.6 [11.3] 6.6	47.4 [13.9] 35.4 [10.4] 6.5	46.2 [13.5] 33.1 [9.7] 6.4	44.4 [13.0] 44.4 [13.0] 6.5	42.9 [12.6] 40.8 [12.0] 6.4	41.8 [12.3] 38.2 [11.2] 6.3

DR —Depression ratio  
dbE —Entering air dry bulb  
wbE—Entering air wet bulb

Total —Total capacity x 1000 BTUH  
Sens —Sensible capacity x 1000 BTUH  
Power—KW input

NOTES: ① When the entering air dry bulb is other than 80°F [27°C], adjust the sensible capacity from the table by adding [1.10 x CFM x (1 - DR) x (dbE - 80)].

[ ] Designates Metric Conversions

**INDOOR AIRFLOW PERFORMANCE RACAZS/RACXZS - 208/230 VOLTS 1-PHASE**

Nominal Cooling Capacity Tons [kW]	Manufacturer Recommended Heat Pump Airflow (Min/Max)	Blower Size/ Motor HP [W] & # of Speeds	Motor Speed	External Static Pressure—Inches W.C. [kPa] (Side Discharge-Dry Coil)										
				0.1 [.02]	0.2 [.05]	0.3 [.07]	0.4 [.10]	0.5 [.12]	0.6 [.15]	0.7 [.17]	0.8 [.20]	0.9 [.22]	1.0 [.25]	
2.0 [7.03]	700 CFM / 900 CFM	10 x 9 Blower 1/3 HP [249W]	Tap 1 Low Heater Kit	CFM [l/s]	709 [335]	650 [307]	568 [268]	510 [241]	459 [217]	391 [185]	332 [157]	301 [142]	277 [131]	244 [115]
				RPM	580	646	707	757	806	869	910	950	990	1038
				Watts	68	76	81	86	90	97	101	104	109	113
			Tap 2 High Heater Kit	CFM [l/s]	855 [404]	802 [379]	758 [358]	706 [333]	582 [275]	545 [257]	514 [243]	471 [222]	422 [199]	380 [179]
				RPM	651	708	754	807	857	896	934	1009	1049	1079
				Watts	101	108	115	121	127	133	137	147	152	156
			Tap 3 AC Low	CFM [l/s]	773 [365]	720 [340]	665 [314]	584 [276]	531 [251]	479 [226]	427 [202]	365 [172]	322 [152]	303 [143]
				RPM	614	670	728	784	824	875	934	978	1015	1053
				Watts	82	88	95	101	105	111	117	122	126	131
			Tap 4 AC High	CFM [l/s]	1020 [481]	984 [464]	943 [445]	897 [423]	853 [403]	812 [383]	753 [355]	713 [336]	676 [319]	641 [303]
				RPM	745	786	827	871	915	960	1006	1043	1073	1107
				Watts	156	163	171	178	186	193	202	208	213	219
			Tap 5 AC Alt. High	CFM [l/s]	900 [425]	857 [404]	808 [381]	758 [358]	696 [328]	648 [306]	610 [288]	564 [266]	519 [245]	458 [216]
				RPM	677	729	776	828	882	920	957	1001	1059	1099
				Watts	115	121	129	136	143	149	154	160	168	174
3.0 [10.55]	1050 CFM / 1350 CFM	12 x 9T Blower 1/2 HP [373W]	Tap 1 Low Heater Kit	CFM [l/s]	869 [410]	804 [379]	675 [319]	549 [259]	487 [230]	406 [192]	340 [160]	301 [142]	229 [108]	174 [82]
				RPM	540	585	661	696	734	777	804	843	877	908
				Watts	84	90	100	104	109	114	117	123	127	131
			Tap 2 High Heater Kit	CFM [l/s]	1096 [517]	1046 [494]	992 [468]	872 [412]	791 [373]	716 [338]	655 [309]	585 [276]	506 [239]	426 [201]
				RPM	635	672	705	774	816	847	876	923	951	968
				Watts	142	150	156	168	176	183	187	196	201	204
			Tap 3 AC Low	CFM [l/s]	950 [448]	886 [418]	780 [368]	685 [323]	576 [272]	504 [238]	430 [203]	346 [163]	330 [156]	266 [126]
				RPM	563	606	673	720	755	805	833	856	898	926
				Watts	100	106	115	123	127	135	139	142	148	151
			Tap 4 AC High	CFM [l/s]	1405 [663]	1361 [642]	1317 [622]	1283 [606]	1237 [584]	1186 [560]	1072 [506]	1014 [479]	956 [451]	887 [419]
				RPM	768	796	828	852	878	904	978	1008	1034	1063
				Watts	271	279	289	295	302	310	332	339	349	357
			Tap 5 AC Alt. High	CFM [l/s]	1631 [770]	1598 [754]	1556 [734]	1510 [713]	1481 [699]	1442 [681]	1401 [661]	1359 [641]	1196 [564]	1091 [515]
				RPM	872	892	921	946	968	992	1018	1040	1102	1117
				Watts	413	420	430	440	448	457	467	475	476	459

**NOTES:** Italic type indicates airflow outside of manufacturers recommendation.  
Do not connect wiring to unspecified speed taps.

[ ] Designates Metric Conversions

**INDOOR AIRFLOW PERFORMANCE RACAZS/RACXZS - 208/230 VOLTS 1-PHASE (Con't.)**

Nominal Cooling Capacity Tons [kW]	Manufacturer Recommended Heat Pump Airflow (Min/Max)	Blower Size/ Motor HP [W] & # of Speeds	Motor Speed	External Static Pressure—Inches W.C. (kPa) (Side Discharge-Dry Coil)											
				0.1 [.02]	0.2 [.05]	0.3 [.07]	0.4 [.10]	0.5 [.12]	0.6 [.15]	0.7 [.17]	0.8 [.20]	0.9 [.22]	1.0 [.25]		
4.0 [14.07]	1400 CFM / 1800 CFM	12 x 9T Blower 3/4 HP [560W]	Tap 1 Low Heater Kit	CFM [l/s]	1095 [517]	1040 [491]	982 [464]	912 [431]	829 [391]	772 [365]	677 [320]	586 [277]	529 [250]	465 [219]	
				RPM	544	596	641	691	739	798	855	902	926	949	
				Watts	125	133	142	148	159	170	182	191	196	202	
			Tap 2 High Heater Kit	CFM [l/s]	1113 [525]	1050 [495]	993 [469]	943 [445]	797 [376]	756 [357]	698 [330]	612 [289]	541 [255]	477 [225]	419 [202]
				RPM	549	601	647	690	765	790	856	898	931	954	
				Watts	125	135	148	147	169	173	185	197	200	204	
			Tap 3 AC Low	CFM [l/s]	1436 [678]	1401 [661]	1346 [635]	1304 [615]	1263 [596]	1220 [576]	1163 [549]	1082 [511]	978 [461]	949 [448]	
				RPM	669	701	747	787	821	853	892	936	999	1011	
				Watts	239	249	265	277	286	297	309	321	342	345	
			Tap 4 AC High	CFM [l/s]	1712 [808]	1673 [790]	1647 [777]	1603 [757]	1565 [738]	1514 [714]	1480 [698]	1444 [682]	1403 [662]	1369 [646]	
				RPM	773	803	828	828	902	939	966	996	1022	1050	
				Watts	387	399	409	423	442	456	466	481	491	503	
			Tap 5 AC Alt. High	CFM [l/s]	1843 [870]	1809 [854]	1776 [838]	1749 [825]	1712 [808]	1670 [788]	1635 [772]	1598 [754]	1560 [736]	1527 [720]	
				RPM	821	853	878	905	935	974	1003	1030	1061	1091	
				Watts	475	491	503	516	529	548	562	574	589	604	
5.0 [17.58]	1750 CFM / 2250 CFM	12 x 9T Blower 1 HP [746W]	Tap 1 Low Heater Kit	CFM [l/s]	1121 [529]	1060 [500]	1003 [473]	949 [448]	835 [394]	764 [361]	692 [327]	632 [298]	0 [0]		
				RPM	588	637	683	725	798	839	878	909	0		
				Watts	157	168	177	187	203	211	219	226	0		
			Tap 2 High Heater Kit	CFM [l/s]	1442 [681]	1392 [657]	1344 [634]	1293 [610]	1243 [587]	1198 [565]	1170 [552]	1062 [501]	981 [463]	919 [434]	
				RPM	721	758	795	834	872	902	929	998	1042	1072	
				Watts	299	310	323	336	349	359	368	390	405	416	
			Tap 3 AC Low	CFM [l/s]	1404 [663]	1357 [640]	1307 [617]	1253 [591]	1205 [569]	1159 [547]	1093 [516]	998 [471]	931 [439]	869 [410]	
				RPM	696	734	772	812	849	879	930	986	1021	1052	
				Watts	271	283	295	308	319	329	345	363	374	384	
			Tap 4 AC High	CFM [l/s]	1974 [932]	1937 [914]	1899 [896]	1864 [880]	1822 [860]	1780 [840]	1738 [820]	1696 [800]	1650 [779]	1606 [758]	
				RPM	919	945	973	1000	1032	1061	1087	1116	1144	1168	
				Watts	712	729	745	761	780	797	812	829	845	859	
			Tap 5 AC Alt. High	CFM [l/s]	2084 [984]	2050 [967]	2015 [951]	1978 [934]	1940 [916]	1905 [899]	1862 [879]	1822 [860]	1777 [839]	1738 [820]	
				RPM	956	986	1014	1041	1065	1091	1121	1148	1171	1195	
				Watts	826	848	867	885	900	917	936	954	967	983	

NOTES: *Italic type* indicates airflow outside of manufacturer's recommendation.  
Do not connect wiring to unspecified speed taps.

DOWN DISCHARGE PRESSURE DROP (ADD TO EXTERNAL STATIC PRESSURE)				
CFM [L/s]	600 [283]	800 [378]	1000 [472]	1200 [566]
Pressure Drop—Includes W.C. [kPa]	0	.02 [.005]	.05 [.012]	.07 [.017]
			.1 [.025]	.12 [.030]
			.15 [.037]	.17 [.042]

[ I ] Designates Metric Conversions

**INDOOR AIRFLOW PERFORMANCE RACAZS/RACXZS - 208/230 VOLTS 3-PHASE**

Nominal Cooling Capacity Tons [kW]	Manufacturer Recommended Heat Pump Airflow (Min/Max)	Blower Size/ Motor HP [W] & # of Speeds	Motor Speed	External Static Pressure—Inches W.C. [kPa] (Side Discharge-Dry Coil)										
				0.1 [0.2]	0.2 [0.05]	0.3 [0.07]	0.4 [0.10]	0.5 [0.12]	0.6 [0.15]	0.7 [0.17]	0.8 [0.20]	0.9 [0.22]	1.0 [0.25]	
3.0 [10.55]	1050 CFM/ 1350 CFM	Tap 1 Low Heater Kit	CFM [l/s]	869 [410]	804 [379]	675 [319]	549 [259]	487 [230]	406 [192]	340 [160]	301 [142]	229 [108]	174 [82]	
			RPM	540	585	661	696	734	777	804	843	877	908	
			Watts	84	90	100	104	109	114	117	123	127	131	
		Tap 2 High Heater kit	CFM [l/s]	1096 [517]	1046 [494]	992 [468]	872 [412]	791 [373]	716 [338]	655 [309]	585 [276]	506 [239]	426 [201]	
			RPM	635	672	705	774	816	847	876	923	951	968	
			Watts	142	150	156	168	176	183	187	196	201	204	
		Tap 3 AC Low	CFM [l/s]	805 [380]	728 [344]	582 [275]	498 [235]	394 [186]	303 [143]	259 [122]	193 [91]	0 [0]	0 [0]	
			RPM	509	560	628	671	724	740	791	820	0	0	
			Watts	71	77	84	89	94	97	102	106	0	0	
		Tap 4 AC High	CFM [l/s]	1253 [591]	1203 [568]	1156 [546]	1109 [523]	1012 [478]	934 [441]	856 [404]	788 [372]	728 [344]	679 [320]	
			RPM	701	738	767	795	858	902	935	962	988	1029	
			Watts	198	207	215	220	235	245	254	259	266	276	
		Tap 5 AC Alt. High	CFM [l/s]	1516 [715]	1480 [698]	1440 [680]	1404 [663]	1352 [638]	1312 [619]	1268 [598]	1145 [540]	1089 [514]	1014 [479]	
			RPM	821	851	874	902	932	956	981	1055	1086	1100	
			Watts	337	348	354	365	372	381	389	414	421	420	
4.0 [14.07]	1400 CFM/ 1800 CFM	Tap 1 Low HeaterKit	CFM [l/s]	1113 [525]	1050 [495]	993 [469]	943 [445]	797 [376]	756 [357]	698 [330]	612 [289]	541 [255]	477 [225]	
			RPM	549	601	647	690	765	790	856	898	931	954	
			Watts	125	135	148	147	169	173	185	197	200	204	
		Tap 2 High Heater Kit	CFM [l/s]	1436 [678]	1401 [661]	1346 [635]	1304 [615]	1263 [596]	1220 [576]	1163 [549]	1082 [511]	978 [461]	949 [448]	
			RPM	669	701	747	787	821	853	892	936	999	1011	
			Watts	239	249	265	277	286	297	309	321	342	345	
		Tap 3 AC Low	CFM [l/s]	1113 [525]	1050 [495]	993 [469]	943 [445]	797 [376]	756 [357]	698 [330]	612 [289]	541 [255]	477 [225]	
			RPM	549	601	647	690	765	790	856	898	931	954	
			Watts	125	135	148	147	169	173	185	197	200	204	
		Tap 4 AC High	CFM [l/s]	1595 [753]	1555 [734]	1514 [714]	1463 [690]	1423 [672]	1390 [656]	1351 [637]	1311 [619]	1257 [593]	1214 [573]	
			RPM	724	759	789	836	867	902	928	956	993	1023	
			Watts	316	330	336	353	366	380	388	400	414	428	
		Tap 5 AC Alt. High	CFM [l/s]	1843 [870]	1809 [854]	1776 [838]	1749 [825]	1712 [808]	1670 [788]	1635 [772]	1598 [754]	1560 [736]	1527 [720]	
			RPM	821	853	878	905	935	974	1003	1030	1061	1091	
			Watts	475	491	503	516	529	548	562	574	589	604	

**NOTES:** Italic type indicates airflow outside of manufacturers recommendation.  
Do not connect wiring to unspecified speed taps.

[ ] Designates Metric Conversions

**INDOOR AIRFLOW PERFORMANCE RACAZS/RACXZS - 208/230 VOLTS 3-PHASE (Con't.)**

Nominal Cooling Capacity Tons [kW]	Manufacturer Recommended Heat Pump Airflow (Min/Max)	Blower Size/ Motor HP [W] & # of Speeds	Motor Speed	External Static Pressure—Inches W.C. [kPa] (Side Discharge-Dry Coil)													
				0.1 [0.2]	0.2 [0.05]	0.3 [0.07]	0.4 [0.10]	0.5 [0.12]	0.6 [0.15]	0.7 [0.17]	0.8 [0.20]	0.9 [0.22]	1.0 [0.25]				
5.0 [17.58]	1750 CFM/ 2250 CFM	12 x 9T Blower 1 HP [746W]	Tap 1 Low Heater Kit	CFM [l/s]	1121 [529]	1060 [500]	1003 [473]	949 [448]	835 [394]	764 [361]	692 [327]	632 [298]	0 [0]	0 [0]	0 [0]		
				RPM	588	637	683	725	798	839	878	909	0	0	0		
				Watts	157	168	177	187	203	211	219	226	0	0	0		
			Tap 2 High Heater Kit	CFM [l/s]	1442 [681]	1392 [657]	1344 [634]	1293 [610]	1243 [587]	1198 [565]	1170 [552]	1062 [501]	998	1042	919 [434]	1072	416
				RPM	721	758	795	834	872	902	929	951 [449]	882 [416]	818 [386]	756 [357]	1030	336
				Watts	299	310	323	336	349	359	368	306	285	276	285	317	327
			Tap 3 AC Low	CFM [l/s]	1319 [622]	1265 [597]	1208 [570]	1153 [544]	1123 [530]	1074 [507]	951 [449]	882 [416]	818 [386]	756 [357]	1030	336	336
				RPM	662	702	746	786	819	852	928	928	965	999	1030	336	336
				Watts	232	243	256	267	276	285	306	306	317	327	336	336	336
			Tap 4 AC High	CFM [l/s]	1872 [883]	1835 [866]	1794 [847]	1756 [829]	1715 [809]	1676 [791]	1629 [769]	1586 [749]	1545 [729]	1500 [708]	1129	732	732
				RPM	873	899	930	959	989	1020	1053	1081	1105	1129	732	732	732
				Watts	596	610	626	642	658	674	691	707	720	732	732	732	732
			Tap 5 AC Alt. High	CFM [l/s]	2084 [984]	2050 [967]	2015 [951]	1978 [934]	1940 [916]	1905 [899]	1862 [879]	1822 [860]	1777 [839]	1738 [820]	1195	983	983
				RPM	956	986	1014	1041	1065	1091	1121	1148	1171	1195	983	983	983
				Watts	826	848	867	885	900	917	936	954	967	983	983	983	983

NOTES: *Italic type indicates airflow outside of manufacturers recommendation.*  
Do not connect wiring to unspecified speed taps.

DOWN DISCHARGE PRESSURE DROP (ADD TO EXTERNAL STATIC PRESSURE)								
CFM [L/s]	600 [283]	800 [378]	1000 [472]	1200 [566]	1400 [661]	1600 [755]	1800 [849]	2000 [944]
Pressure Drop—Includes W.C. [kPa]	0	.02 [.005]	.05 [.012]	.07 [.017]	.1 [.025]	.12 [.030]	.15 [.037]	.17 [.042]

[ I ] Designates Metric Conversions

**INDOOR AIRFLOW PERFORMANCE RACAZS/RACXZS - 460 VOLTS 3-PHASE**

Nominal Cooling Capacity Tons [kW]	Manufacturer Recommended Heat Pump Airflow (Min/Max)	Blower Size/ Motor HP [W] & # of Speeds	Motor Speed	External Static Pressure—Inches W.C. [kPa]										
				0.1 [.02]	0.2 [.05]	0.3 [.07]	0.4 [.10]	0.5 [.12]	0.6 [.15]	0.7 [.17]	0.8 [.20]	0.9 [.22]	1.0 [.25]	
3.0 [10.55]	1050 CFM / 1350 CFM	12 x 9T Blower 1HP [746W]	Tap 1 Low Heater Kit	CFM [l/s]	880 [415]	799 [377]	668 [315]	542 [256]	481 [227]	399 [188]	317 [150]	286 [135]	217 [102]	150 [71]
				RPM	541	592	660	695	732	777	792	830	855	887
				Watts	82	89	98	102	108	112	115	118	123	128
			Tap 2 High Heater Kit	CFM [l/s]	1112 [525]	1050 [496]	991 [468]	880 [415]	798 [377]	716 [338]	646 [305]	589 [278]	507 [239]	410 [193]
				RPM	639	678	713	780	815	851	880	928	948	966
				Watts	136	143	149	162	168	175	181	187	194	197
			Tap 3 AC Low	CFM [l/s]	800 [378]	695 [328]	576 [272]	483 [228]	381 [180]	287 [135]	258 [122]	194 [92]	0 [0]	0 [0]
				RPM	517	583	628	670	720	738	777	812	0	0
				Watts	74	78	83	88	94	96	100	103	0	0
			Tap 4 AC High	CFM [l/s]	1271 [600]	1220 [576]	1171 [553]	1117 [527]	1015 [479]	935 [441]	859 [405]	787 [371]	723 [341]	675 [319]
				RPM	707	738	776	807	866	908	936	965	993	1030
				Watts	185	194	202	210	223	232	240	247	253	262
			Tap 5 AC Alt. High	CFM [l/s]	1549 [731]	1504 [710]	1469 [693]	1421 [671]	1379 [651]	1336 [631]	1283 [606]	1174 [554]	1107 [522]	1051 [496]
				RPM	830	857	884	913	937	961	991	1057	1086	1112
				Watts	307	317	325	333	342	350	360	382	393	402
4.0 [14.07]	1400 CFM / 1800 CFM	12 x 9T Blower 3/4 HP [560W]	Tap 1 Low Heater Kit	CFM [l/s]	1103 [521]	1050 [496]	993 [469]	937 [442]	820 [387]	787 [372]	680 [321]	621 [293]	530 [250]	465 [220]
				RPM	547	595	644	689	755	800	861	895	934	954
				Watts	123	133	143	151	164	173	185	191	200	204
			Tap 2 High Heater Kit	CFM [l/s]	1440 [680]	1401 [661]	1367 [645]	1318 [622]	1272 [600]	1220 [576]	1186 [560]	1104 [521]	991 [468]	958 [452]
				RPM	676	710	743	787	825	861	892	941	1006	1022
				Watts	240	252	262	275	287	299	308	324	346	351
			Tap 3 AC Low	CFM [l/s]	1018 [480]	957 [452]	898 [424]	789 [372]	706 [333]	641 [303]	540 [255]	461 [218]	403 [190]	358 [169]
				RPM	518	574	618	687	734	803	846	880	902	943
				Watts	103	113	120	132	140	151	158	164	168	174
			Tap 4 AC High	CFM [l/s]	1601 [755]	1557 [735]	1520 [717]	1485 [701]	1453 [686]	1400 [661]	1357 [641]	1322 [624]	1269 [599]	1182 [558]
				RPM	733	766	797	830	863	906	935	967	1005	1057
				Watts	314	327	339	352	364	381	391	402	418	437
			Tap 5 AC Alt. High	CFM [l/s]	1849 [872]	1804 [852]	1773 [837]	1740 [821]	1707 [806]	1675 [790]	1638 [773]	1599 [755]	1565 [738]	1525 [720]
				RPM	817	850	879	904	934	968	999	1034	1060	1096
				Watts	456	471	486	500	512	527	545	562	575	592

**NOTES:** Italic type indicates airflow outside of manufacturers recommendation.  
Do not connect wiring to unspecified speed taps.

**[ I ] Designates Metric Conversions**

**INDOOR AIRFLOW PERFORMANCE RACAZS/RACXZS - 460 VOLTS 3-PHASE**

Nominal Cooling Capacity Tons [kW]	Manufacturer Recommended Heat Pump Airflow (Min/Max)	Blower Size/ Motor HP [W] & # of Speeds	Motor Speed	External Static Pressure—Inches W.C. (kPa) (Side Discharge—Dry Coil)											
				0.1 [.02]	0.2 [.05]	0.3 [.07]	0.4 [.10]	0.5 [.12]	0.6 [.15]	0.7 [.17]	0.8 [.20]	0.9 [.22]	1.0 [.25]		
5.0 [17.58]	1750 CFM / 2250 CFM	Tap 1 Low Heater Kit	CFM [l/s]	1121 [529]	1060 [500]	1003 [473]	949 [448]	835 [394]	764 [361]	692 [327]	632 [298]	0 [0]	0 [0]	0 [0]	
			RPM	588	637	683	725	798	839	878	909	0	0	0	
			Watts	157	168	177	187	203	211	219	226	0	0	0	
		Tap 2 High Heater Kit	CFM [l/s]	1442 [681]	1392 [657]	1344 [634]	1293 [610]	1243 [587]	1198 [565]	1170 [552]	1062 [501]	981 [463]	919 [434]		
			RPM	721	758	795	834	872	902	929	998	1042	1072		
			Watts	299	310	323	336	349	359	368	390	405	416		
		Tap 3 AC Low	CFM [l/s]	1319 [622]	1265 [597]	1208 [570]	1153 [544]	1123 [530]	1074 [507]	951 [449]	882 [416]	818 [386]	756 [357]		
			RPM	662	702	746	786	819	852	928	965	999	1030		
			Watts	232	243	256	267	276	285	306	317	327	336		
		Tap 4 AC High	CFM [l/s]	1872 [883]	1835 [866]	1794 [847]	1756 [829]	1715 [809]	1676 [791]	1629 [769]	1586 [749]	1545 [729]	1500 [708]		
			RPM	873	899	930	959	989	1020	1053	1081	1105	1129		
			Watts	596	610	626	642	658	674	691	707	720	732		
		Tap 5 AC Alt. High	CFM [l/s]	2084 [984]	2050 [967]	2015 [951]	1978 [934]	1940 [916]	1905 [899]	1862 [879]	1822 [860]	1777 [839]	1738 [820]		
			RPM	956	986	1014	1041	1065	1091	1121	1148	1171	1195		
			Watts	826	848	867	885	900	917	936	954	967	983		

NOTES: Italic type indicates airflow outside of manufacturers recommendation.

Do not connect wiring to unspecified speed taps.

DOWN DISCHARGE PRESSURE DROP (ADD TO EXTERNAL STATIC PRESSURE)				
CFM [L/s]	600 [283]	800 [378]	1000 [472]	1200 [566]
Pressure Drop—Includes W.C. [kPa]	0	.02 [.005]	.05 [.012]	.07 [.017]
			.12 [.030]	.15 [.037]
			.17 [.042]	

[ ] Designates Metric Conversions



**ELECTRICAL DATA - RACA ZS SERIES**

		<b>024AJT</b>	<b>036ACT</b>	<b>036ADT</b>	<b>036AJT</b>
<b>Unit Information</b>	Unit Operating Voltage Range	187-253	187-253	414-506	187-253
	Volts	208/230	208/230	460	208/230
	Phase	1	3	3	1
	Hz	60	60	60	60
	Minimum Circuit Ampacity	18	17	10	25
	Minimum Overcurrent Protection Device Size	25	20	15	30
	Maximum Overcurrent Protection Device Size	25	25	15	40
<b>Compressor Motor</b>	No.	1	1	1	1
	Volts	208/230	208/230	460	208/230
	Phase	1	3	3	1
	RPM	3500	3500	3500	3500
	HP, Compressor 1				
	Amps (RLA), Comp. 1	10.9	8.8	4	15.3
	Amps (LRA), Comp. 1	55.2	70	31	78.1
	HP, Compressor 2				
	Amps (RLA), Comp. 2				
Amps (LRA), Comp. 2					
<b>Condenser Motor</b>	No.	1	1	1	1
	Volts	208/230	208/230	460	208/230
	Phase	1	1	1	1
	HP	1/6	1/3	1/3	1/3
	Amps (FLA, each)	0.6	1.5	0.8	1.5
	Amps (LRA, each)	1.5	3	1.6	3
<b>Evaporator Fan</b>	No.	1	1	1	1
	Volts	208/230	208/230	460	208/230
	Phase	1	1	1	1
	HP	1/3	1	1	1
	Amps (FLA, each)	2.8	4.1	4	4.1
	Amps (LRA, each)				

**ELECTRICAL DATA - RACXZS SERIES**

		<b>048ACT</b>	<b>048ADT</b>	<b>048AJT</b>	<b>060ACT</b>	<b>060ADT</b>	<b>060AJT</b>
<b>Unit Information</b>	Unit Operating Voltage Range	187-253	414-506	187-253	187-253	414-506	187-253
	Volts	208/230	460	208/230	208/230	460	208/230
	Phase	3	3	1	3	3	1
	Hz	60	60	60	60	60	60
	Minimum Circuit Ampacity	24	12	33	28	13	39
	Minimum Overcurrent Protection Device Size	30	15	40	35	15	45
	Maximum Overcurrent Protection Device Size	35	15	50	40	15	60
<b>Compressor Motor</b>	No.	1	1	1	1	1	1
	Volts	208/230	460	208/230	208/230	460	208/230
	Phase	3	3	1	3	3	1
	RPM	3500	3500	3500	3500	3500	3500
	HP, Compressor 1						
	Amps (RLA), Comp. 1	12.6	6	19.9	14	6.5	23.5
	Amps (LRA), Comp. 1	123	60	109	93	60	118
	HP, Compressor 2						
	Amps (RLA), Comp. 2						
Amps (LRA), Comp. 2							
<b>Condenser Motor</b>	No.	1	1	1	1	1	1
	Volts	208/230	460	208/230	208/230	208/230	208/230
	Phase	1	1	1	1	1	1
	HP	1/3	1/3	1/3	1/3	1/3	1/3
	Amps (FLA, each)	2	1	2	2	1	2
	Amps (LRA, each)	3.9	2.2	3.9	3.9	2.2	3.9
<b>Evaporator Fan</b>	No.	1	1	1	1	1	1
	Volts	208/230	460	208/230	208/230	460	208/230
	Phase	1	1	1	1	1	1
	HP	1	1	1	1	1	1
	Amps (FLA, each)	6	2.7	6	7.6	4	7.6
	Amps (LRA, each)						

208/240 VOLT, THREE PHASE, 60 Hz, AUXILIARY ELECTRIC HEATER KITS CHARACTERISTICS AND APPLICATION									
Single Power Supply for Both Unit and Heater Kit					Separate Power Supply for Both Unit and Heater Kit				
Model Number RACAZS	Heater Kit			Air Conditioner		Heater Kit		Air Conditioner	
	RXQJ-Heater Kit Nominal kW	Rated Heater kW @ 208/240 V	Heater Amp. @ 208/240 V	Unit Min. Ckt. Ampacity @ 208/240 V	Over Current Protective Device Size Min./Max	Min. Ckt. Ampacity 208/240V	Max. Fuse Size 208/240V	Min. Circuit Ampacity 208/240V	Over Current Protective Device Size Min./Max
036ACT000NA HEATER KW	NONE	—	—	17/17	25/25	—	—	17/17	25/25
	A05C	3.8/5	10.4/12	19/21	25/25	13/15	15/15	17/17	25/25
	A08C	5.7/7.6	15.9/18.3	25/28	25/30	20/23	20/25	17/17	25/25
	A10C	7.2/9.6	20/23.1	31/34	35/35	25/29	25/30	17/17	25/25
	A15C	10.8/14.4	30.1/34.7	43/49	45/50	38/44	40/45	17/17	25/25

480 VOLT, THREE PHASE, 60 Hz, AUXILIARY ELECTRIC HEATER KITS CHARACTERISTICS AND APPLICATION									
Single Power Supply for Both Unit and Heater Kit					Separate Power Supply for Both Unit and Heater Kit				
Model Number RACAZS	Heater Kit			Air Conditioner		Heater Kit		Air Conditioner	
	RXQJ-Heater Kit Nominal kW	Rated Heater kW @ 480 V	Heater Amp. @ 480 V	Unit Min. Ckt. Ampacity @ 480 V	Over Current Protective Device Size Min./Max	Min. Ckt. Ampacity 480V	Max. Fuse Size 480V	Min. Circuit Ampacity 480V	Over Current Protective Device Size Min./Max
036ADT000NA HEATER KW	NONE	—	—	10	15	—	—	10	15
	A05D	4.8	5.8	12	15	8	15	10	15
	A08D	7.6	9.1	16	20	12	15	10	15
	A10D	9.6	11.6	19	20	15	15	10	15
	A15D	14.4	17.3	26	30	22	25	10	15

208/240 VOLT, SINGLE PHASE, 60 Hz, AUXILIARY ELECTRIC HEATER KITS CHARACTERISTICS AND APPLICATION									
Single Power Supply for Both Unit and Heater Kit					Separate Power Supply for Both Unit and Heater Kit				
Model Number RACAZS	Heater Kit			Air Conditioner		Heater Kit		Air Conditioner	
	RXQJ-Heater Kit Nominal kW	Rated Heater kW @ 208/240 V	Heater Amp. @ 208/240 V	Unit Min. Ckt. Ampacity @ 208/240 V	Over Current Protective Device Size Min./Max	Min. Ckt. Ampacity 208/240V	Max. Fuse Size 208/240V	Min. Circuit Ampacity 208/240V	Over Current Protective Device Size Min./Max
024AJT000NA HEATER KW	NONE	—	—	18/18	25/25	—	—	18/18	25/25
	A05J	3.6/4.8	17.3/20	26/29	30/30	22/25	25/25	18/18	25/25
	A08J	5.7/7.6	27.4/31.6	39/44	40/45	35/40	35/40	18/18	25/25
	A10J	7.2/9.6	34.6/40	48/54	50/60	44/50	45/50	18/18	25/25
036AJT000NA HEATER KW	NONE	—	—	25/25	40/40	—	—	25/25	40/40
	A05J	3.6/4.8	17.3/20	27/31	40/40	22/25	25/25	25/25	40/40
	A08J	5.7/7.6	27.4/31.6	40/45	40/45	35/40	35/40	25/25	40/40
	A10J	7.2/9.6	34.6/40	49/56	50/60	44/50	45/50	25/25	40/40
	A15J	10.8/14.4	51.9/60	70/81	70/90	65/75	70/80	25/25	40/40

**208/240 VOLT, THREE PHASE, 60 Hz, AUXILIARY ELECTRIC HEATER KITS CHARACTERISTICS AND APPLICATION**

208/240 VOLT, THREE PHASE, 60 Hz, AUXILIARY ELECTRIC HEATER KITS CHARACTERISTICS AND APPLICATION									
Single Power Supply for Both Unit and Heater Kit					Separate Power Supply for Both Unit and Heater Kit				
Model Number RACXZS	Heater Kit			Air Conditioner		Heater Kit		Air Conditioner	
	RXQJ-Heater Kit Nominal kW	Rated Heater kW @ 208/240 V	Heater Amp. @ 208/240 V	Unit Min. Ckt. Ampacity @ 208/240 V	Over Current Protective Device Size Min./Max	Min. Ckt. Ampacity 208/240V	Max. Fuse Size 208/240V	Min. Circuit Ampacity 208/240V	Over Current Protective Device Size Min./Max
048ACT000NA HEATER KW	NONE	—	—	24/24	35/35	—	—	24/24	35/35
	A05C	3.8/5	10.4/12	24/24	35/35	13/15	15/15	24/24	35/35
	A08C	5.7/7.6	15.9/18.3	28/31	35/35	20/23	20/25	24/24	35/35
	A10C	7.2/9.6	20/23.1	33/37	35/40	25/29	25/30	24/24	35/35
	A15C	10.8/14.4	30.1/34.7	46/51	50/60	38/44	40/45	24/24	35/35
060ADT000NA HEATER KW	NONE	—	—	28/28	40/40	—	—	28/28	40/40
	A05C	3.8/5	10.4/12	28/28	40/40	13/15	15/15	28/28	40/40
	A08C	5.7/7.6	15.9/18.3	30/33	40/40	20/23	20/25	28/28	40/40
	A10C	7.2/9.6	20/23.1	35/39	40/40	25/29	25/30	28/28	40/40
	A15C	10.8/14.4	30.1/34.7	48/53	50/60	38/44	40/45	28/28	40/40

**480 VOLT, THREE PHASE, 60 Hz, AUXILIARY ELECTRIC HEATER KITS CHARACTERISTICS AND APPLICATION**

480 VOLT, THREE PHASE, 60 Hz, AUXILIARY ELECTRIC HEATER KITS CHARACTERISTICS AND APPLICATION									
Single Power Supply for Both Unit and Heater Kit					Separate Power Supply for Both Unit and Heater Kit				
Model Number RACXZS	Heater Kit			Air Conditioner		Heater Kit		Air Conditioner	
	RXQJ-Heater Kit Nominal kW	Rated Heater kW @ 480 V	Heater Amp. @ 480 V	Unit Min. Ckt. Ampacity @ 480 V	Over Current Protective Device Size Min./Max	Min. Ckt. Ampacity 480V	Max. Fuse Size 480V	Min. Circuit Ampacity 480V	Over Current Protective Device Size Min./Max
048ADT000NA HEATER KW	NONE	—	—	12	15	—	—	12	15
	A05D	4.8	5.8	12	15	8	15	12	15
	A08D	7.6	9.1	15	15	12	15	12	15
	A10D	9.6	11.6	18	20	15	15	12	15
	A15D	14.4	17.3	25	25	22	25	12	15
060ADT000NA HEATER KW	NONE	—	—	13	15	—	—	13	15
	A05D	4.8	5.8	13	15	8	15	13	15
	A08D	7.6	9.1	17	20	12	15	13	15
	A10D	9.6	11.6	20	20	15	15	13	15
	A15D	14.4	17.3	27	30	22	25	13	15

**208/240 VOLT, SINGLE PHASE, 60 Hz, AUXILIARY ELECTRIC HEATER KITS CHARACTERISTICS AND APPLICATION**

208/240 VOLT, SINGLE PHASE, 60 Hz, AUXILIARY ELECTRIC HEATER KITS CHARACTERISTICS AND APPLICATION									
Single Power Supply for Both Unit and Heater Kit					Separate Power Supply for Both Unit and Heater Kit				
Model Number RACXZS	Heater Kit			Air Conditioner		Heater Kit		Air Conditioner	
	RXQJ-Heater Kit Nominal kW	Rated Heater kW @ 208/240 V	Heater Amp. @ 208/240 V	Unit Min. Ckt. Ampacity @ 208/240 V	Over Current Protective Device Size Min./Max	Min. Ckt. Ampacity 208/240V	Max. Fuse Size 208/240V	Min. Circuit Ampacity 208/240V	Over Current Protective Device Size Min./Max
048AJT000NA HEATER KW	NONE	—	—	33/33	50/50	—	—	33/33	50/50
	A05J	3.6/4.8	17.3/20	33/33	50/50	22/25	25/25	33/33	50/50
	A08J	5.7/7.6	27.4/31.6	42/47	50/50	35/40	35/40	33/33	50/50
	B10J	7.2/9.6	34.6/40	51/58	60/60	44/50	45/50	33/33	50/50
	B15J	10.8/14.4	51.9/60	73/83	80/90	65/75	70/80	33/33	50/50
060AJT000NA HEATER	NONE	—	—	39/39	60/60	—	—	39/39	60/60
	A05J	3.6/4.8	17.3/20	39/39	60/60	22/25	25/25	39/39	60/60
	A08J	5.7/7.6	27.4/31.6	44/49	60/60	35/40	35/40	39/39	60/60
	B10J	7.2/9.6	34.6/40	53/60	60/60	44/50	45/50	39/39	60/60
	B15J	10.8/14.4	51.9/60	75/85	80/90	65/75	70/80	39/39	60/60

## ACCESSORY EQUIPMENT

Accessory Description	Model Application	Accessory Model No.
Roofcurb	RACA	RXSG-AAA08 (8" [203 mm] Height)
		RXSG-AAA14 (14" [356 mm] Height)
	RACX	RXSG-AXA14 (14" [356 mm] Height)
		RXSG-AXA24 (24" [610 mm] Height)
Curb Adapter ("A" footprint to "X" footprint)	RACX	RXRX-DXCAE
Duct Adapter Sideflow Square to Round Transition	RACA/X	AXMC-BA01
Supply & Return Diffusers	RACA/X	RXRN-BD15
Rectangular to Round Transition (Downflow)	RACA/X	RXMC-CA02 (16" [406 mm] Ducts)
		RXMC-CA03 (18" [457 mm] Ducts)
Economizers (Convertible)	RACA	AXRD-01RACAM3
	RACX	RXRE-11RXCAM3
Dual Enthalpy Kit	RACA	RXRX-AV04
	RACX	PD555460
Fresh Air Damper $\beta$	RACA	AXRF-FAA1 (Fixed-35%)
		AXRF-FAB1 (Motorized-35%)
	RACX	RXRF-FAA2 (Fixed-35%)
		RXRF-FAB2 (Motorized-35%)
Filter Kit	RACA	RXRY-B01
	RACX	RXRY-B02
Split Door Design Kit	RACX	RXRX-SDX01
Low Ambient Control	RACA/X	RXPZ-G01
Low Pressure Control	RACA/X	RXAC-C01
Phase Monitor Kit	3ph-RACA/X	RXRX-PM3A01

**NOTE:** High pressure switches are standard for RGEA/X Models.

## COMMON SUPPLY/RETURN CONCENTRIC AIR DIFFUSER

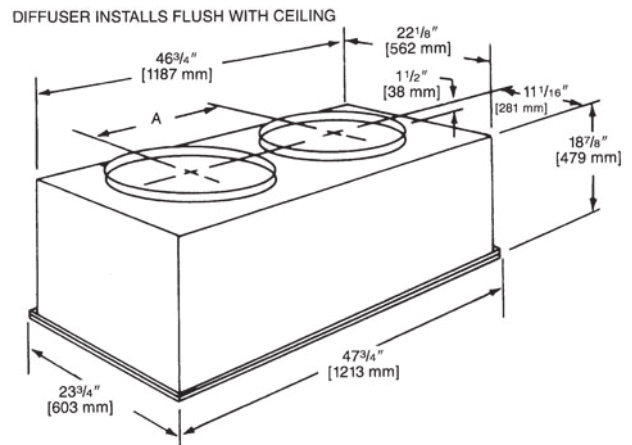
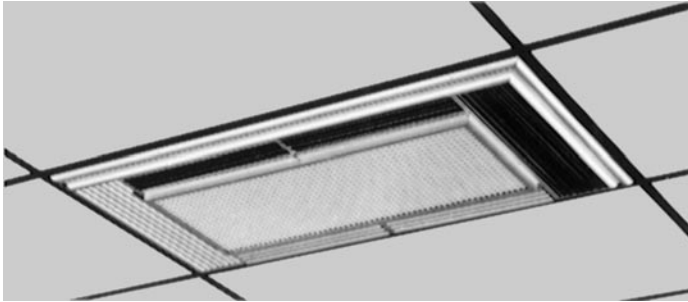

## SUPPLY/RETURN DIFFUSER

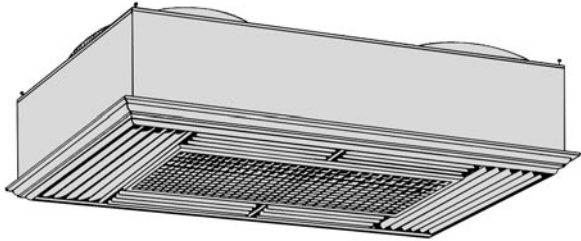

Designed to convert a side by side or an over and under arrangement into a concentric distribution of air. The diffuser is flush mounted, completely insulated, assembled, and internally baffled to provide four way supply air distribution with a center return. To make the assembly complete and ready to fit into a 2' [0.61 m] x 4' [1.22 m] suspended ceiling grid, the diffuser includes adjustable supply louvers, hanging rings, anti-sweat gasket, and round flanges for use with flexible ducts.

**NOTE:** The location of the combination supply and return diffuser should not exceed 10 feet [3.05 m] above the floor level for units @ 1000 CFM [472 L/s] or less and 12 [3.66 m] to 14 feet [4.27 m] above the floor level for units with CFM greater than 1000 [472 L/s]. If the diffuser is installed with a greater distance than recommended above, the supply air may become stratified above the required comfort area causing uncomfortable conditions.

## AIRFLOW/PRESSURE DROP INFORMATION (INCHES W.C. [kPa])

Accessory	Approximate CFM [L/s]-Supply Air			
	1300 [614]	1575 [743]	1800 [850]	2200 [1038]
Plenum & Supply/Return Duct	.07 [.017]	.10 [.024]	.12 [.030]	.17 [.042]
Diffuser	.09 [.022]	.13 [.032]	.16 [.040]	.24 [.060]
Economizer	.06 [.015]	.09 [.022]	.11 [.027]	.17 [.042]

## SUPPLY AIR/PERFORMANCE

Diffuser Airflow CFM [L/s]	Range of Throw Ft. [m]
800 [378]-1200 [566]	14 [4.27]-16 [4.88]
1600 [755]-2000 [944]	18 [5.49]-28 [8.53]

Model No. RXRN-	Diameter Inches [mm]	Shipping Wt. Lbs. [kg]	Dimension A Inches [mm]
BD15	16 [406]	90 [40.82]	20 1/2 [521]

# DUCT ADAPTERS RECTANGULAR TO ROUND TRANSITIONS (DOWNFLOW)

**RXMC-CA02**

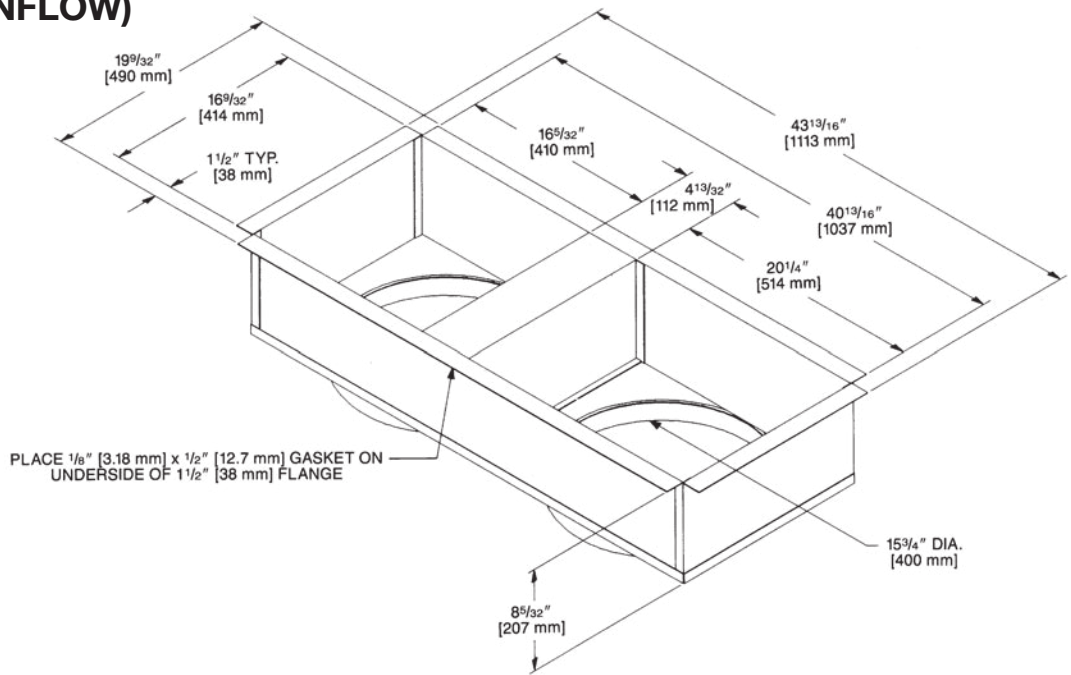

**RXMC-CA03**

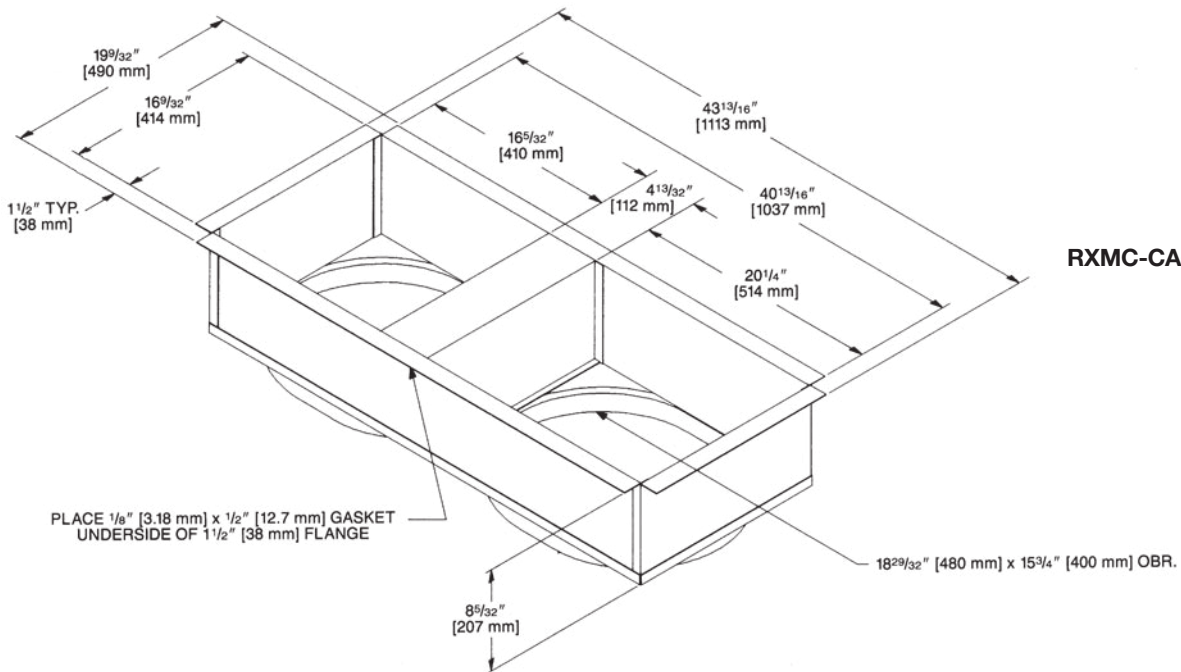

[ ] Designates Metric Conversions

## DUCT ADAPTER SIDEFLOW SQUARE TO ROUND TRANSITION AXMC-BA01

Adapts the side rectangular supply and return openings to 14" [356 mm] diameter round openings. Adapters provided with same finish as unit and also provided with thermal insulation.

[ ] Designates Metric Conversions

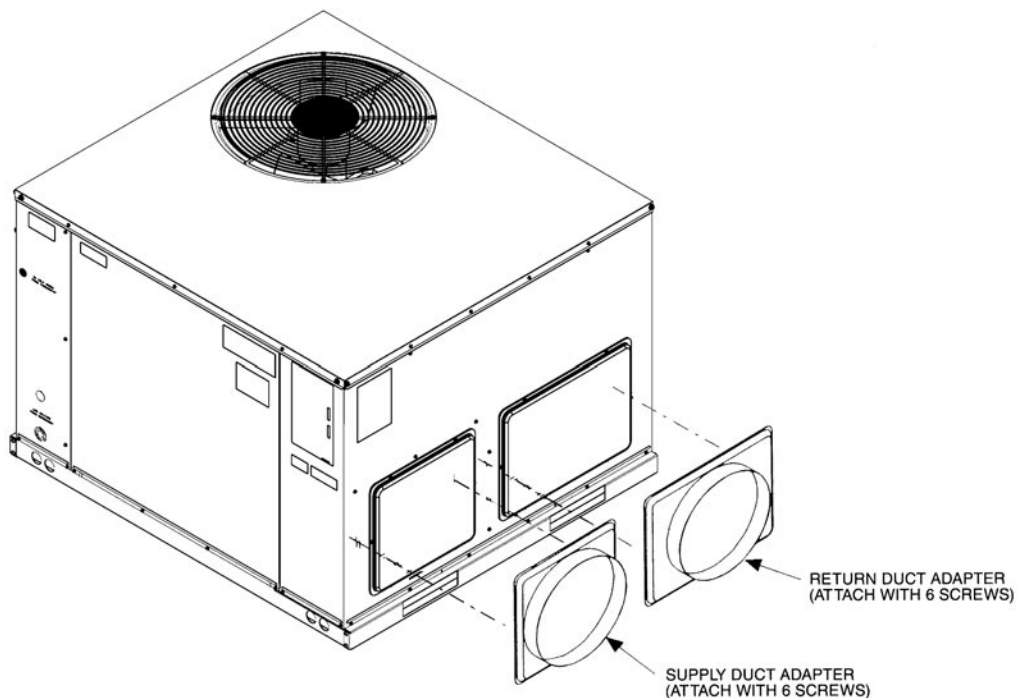



**ROOFCURB (Full Perimeter)**  
**RXSG-AAA08, RXSG-AAA14 - for**  
**the "A" cabinet.**

Hinged corners make for fast, easy set-up.

**RXSG-AAA08**  
**(8" [203 mm] High)**

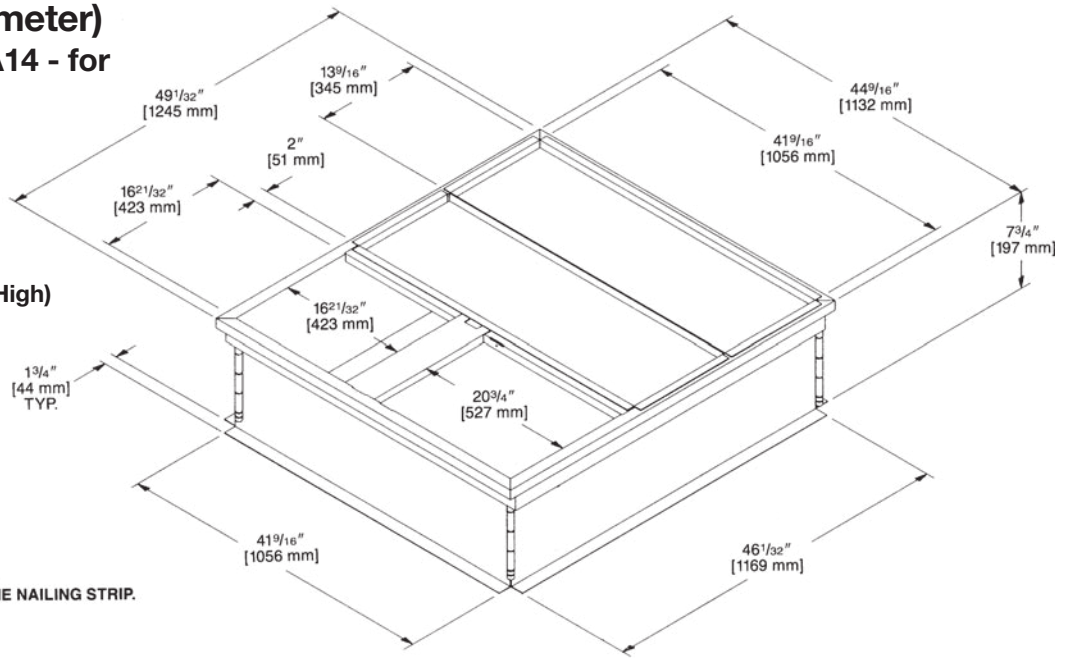

NOTE: PERIMETER OF ROOFCURB IS SUPPLIED WITH A NOMINAL 1" [25.4 mm] x 4" [102 mm] PINE NAILING STRIP.

**RXSG-AAA14**  
**(14" [356 mm] High)**

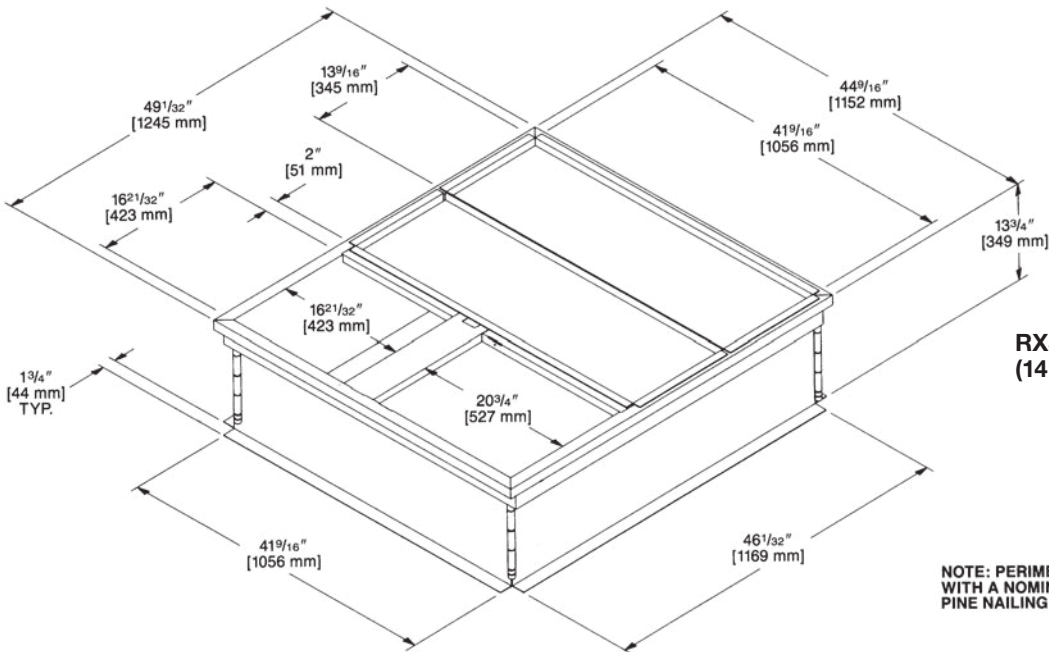

NOTE: PERIMETER OF ROOFCURB IS SUPPLIED WITH A NOMINAL 1" [25.4 mm] x 4" [102 mm] PINE NAILING STRIP.

[ ] Designates Metric Conversions

**ROOFCURB (Full Perimeter)**  
**RXSG-AXA14, RXSG-AXA24 - for**  
**the "X" cabinet.**

Hinged corners make for  
 fast, easy set-up.

**RXSG-AXA14**  
**(14" [356 mm] Height)**

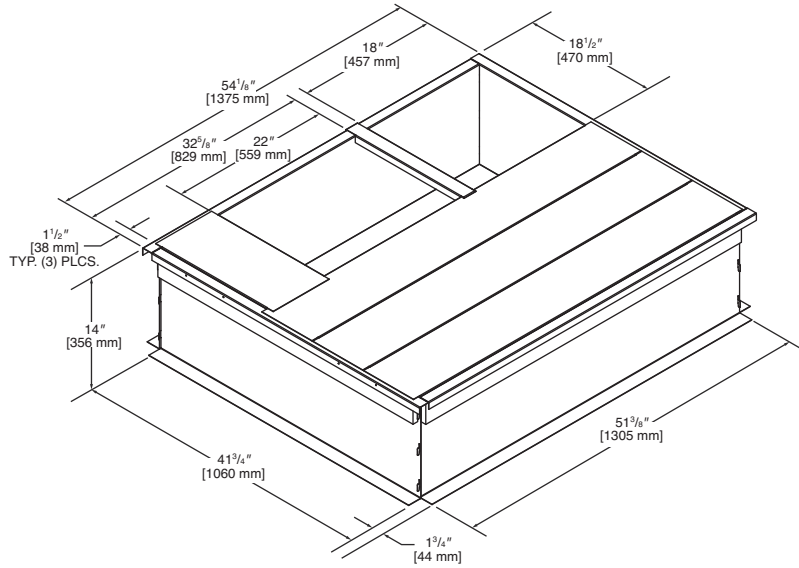

Illustration  
 ST-A1334-14-00

**RXSG-AXA24**  
**(24" [610 mm] Height)**

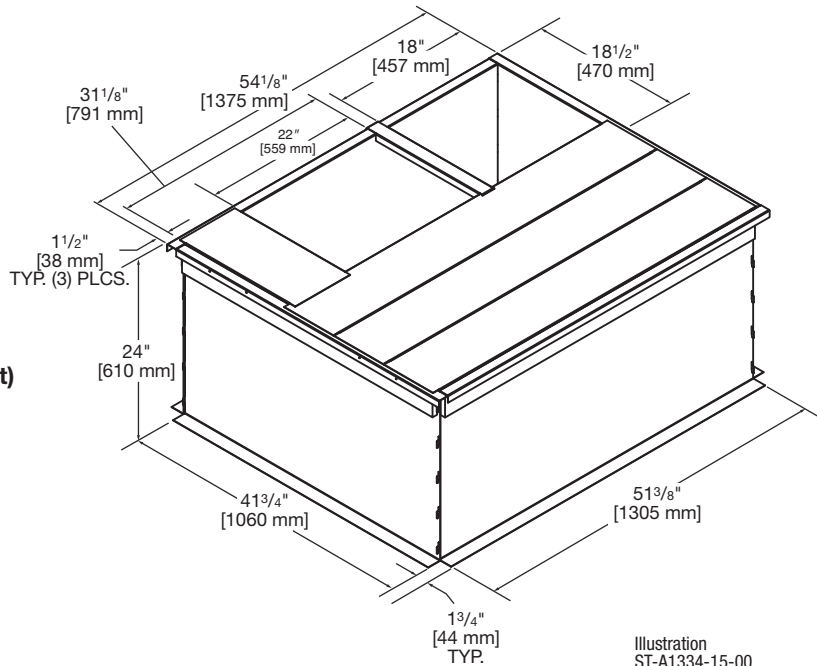
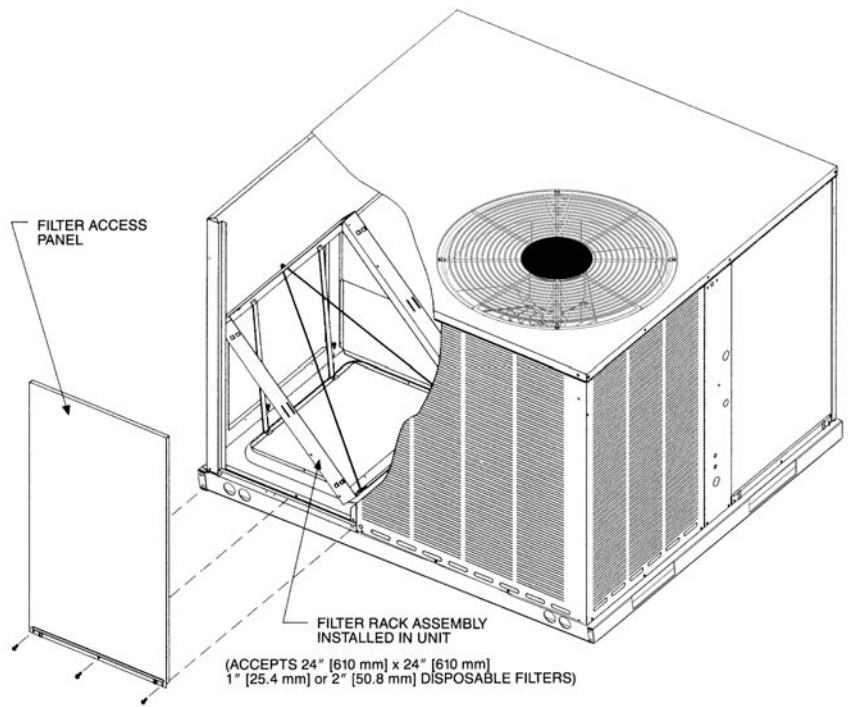

Illustration  
 ST-A1334-15-00



## FILTER KIT INSTALLATION RXRY-B01

For use in either vertical  
or horizontal discharge (with "A" cabinet).



Airflow Pressure Drop, Inches W.C. [kPa]		
CFM [L/s]	1" Filter	2" Filter
500 [236]	.02 [.0050]	.03 [.0075]
600 [283]	.02 [.0050]	.03 [.0075]
700 [330]	.03 [.0075]	.04 [.0101]
800 [378]	.04 [.0101]	.05 [.0124]
900 [425]	.05 [.0124]	.06 [.0149]
1000 [472]	.07 [.0174]	.08 [.0199]
1100 [519]	.08 [.0199]	.09 [.0224]
1200 [566]	.10 [.0249]	.12 [.0299]
1300 [614]	.13 [.0324]	.15 [.0373]
1400 [661]	.16 [.0398]	.19 [.0473]
1500 [708]	.19 [.0473]	.21 [.0523]
1600 [755]	.20 [.0498]	.23 [.0572]
1700 [802]	.21 [.0523]	.24 [.0598]
1800 [850]	.22 [.0548]	.25 [.0623]
1900 [897]	.24 [.0598]	.27 [.0672]
2000 [944]	.26 [.0647]	.29 [.0722]

[ ] Designates Metric Conversions

## FILTER KIT INSTALLATION

### RXRY-B02

For use in either vertical or horizontal discharge with the "X" cabinet.

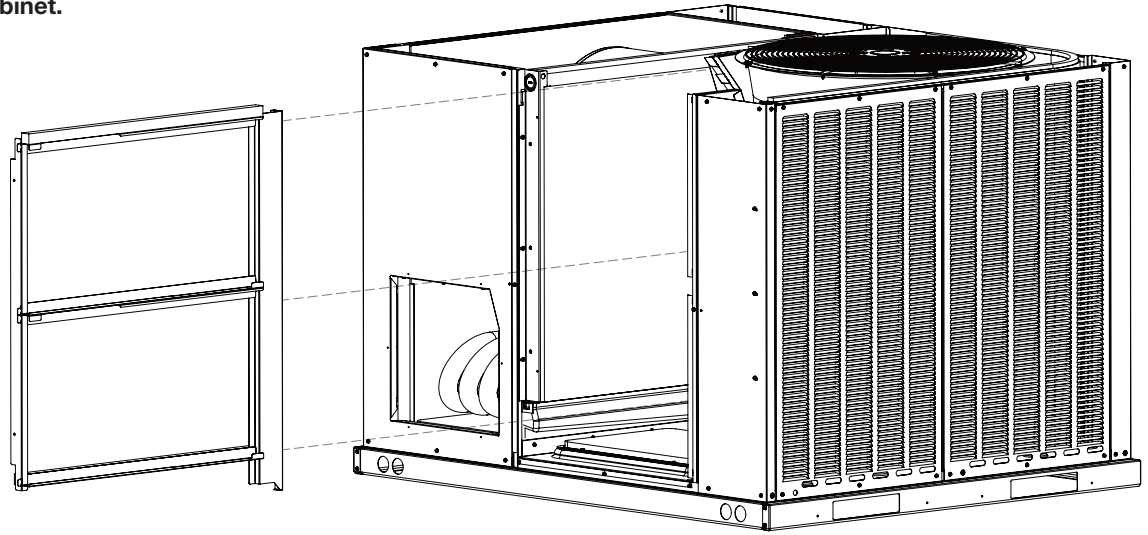

Illustration  
ST-A1352-01-00

Airflow Pressure Drop (1" filter)	
CFM [L/s]	Inches W.C. [kPa]
600 [283]	0.01 [0.002]
800 [378]	0.01 [0.002]
1000 [472]	0.02 [0.005]
1200 [566]	0.03 [0.008]
1400 [661]	0.05 [0.012]
1600 [755]	0.07 [0.017]
1800 [850]	0.08 [0.021]
2000 [944]	0.10 [0.026]

[ ] Designates Metric Conversions

## FRESH AIR DAMPER FOR USE ON RAC(A/X)ZS Series

### AXRF-FAA1 (Fixed - 0-35%) - RACA

### AXRF-FAA2 (Fixed - 0-35%) - RACX

The 0-35% manual outside Air Damper is designed to replace the unit return air duct cover. No drilling or damper assembly is required. The amount of outside air (0-35%) is controlled by simply adjusting the side damper.

### AXRF-FAB1 (Motorized - 0-35%) - RACA

### AXRF-FAB2 (Motorized - 0-35%) - RACX

The 0-35% motorized outside Air Damper is designed to replace the unit return air duct cover. No drilling or damper assembly is required. The control motor opens the adjustable slide damper when the unit blower motor is energized.

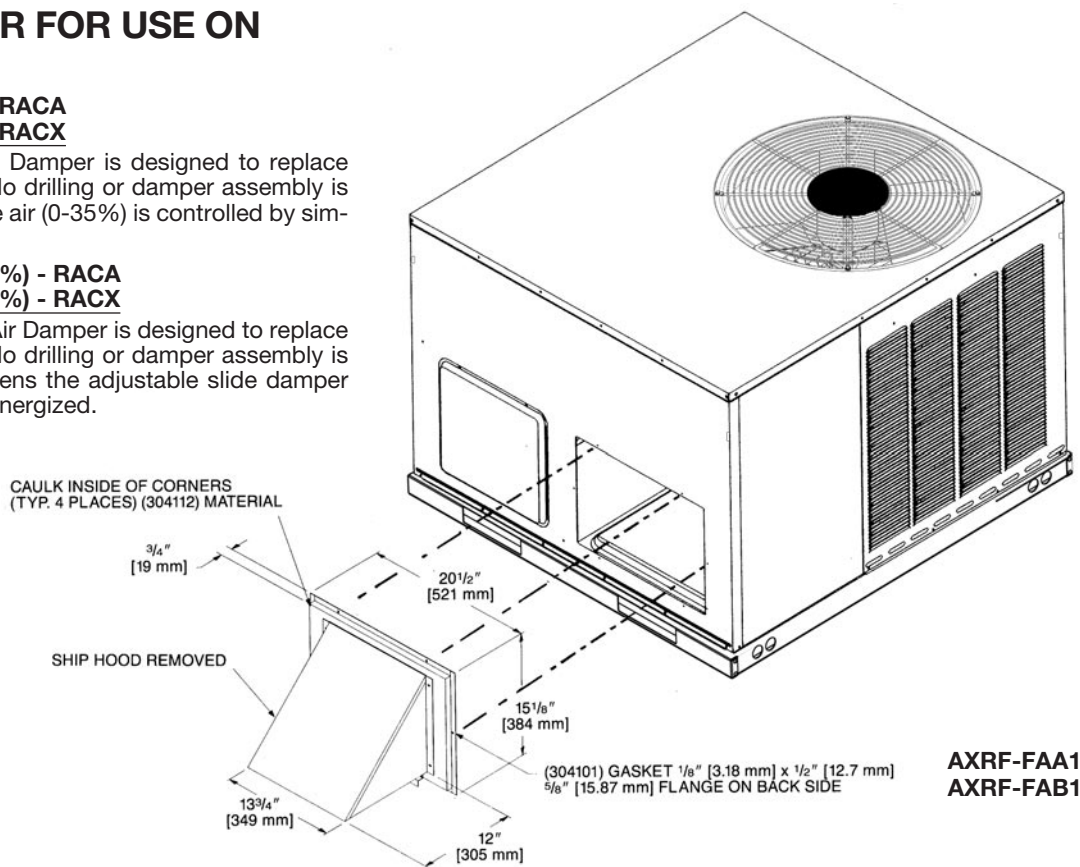

AXRF-FAA1  
AXRF-FAB1

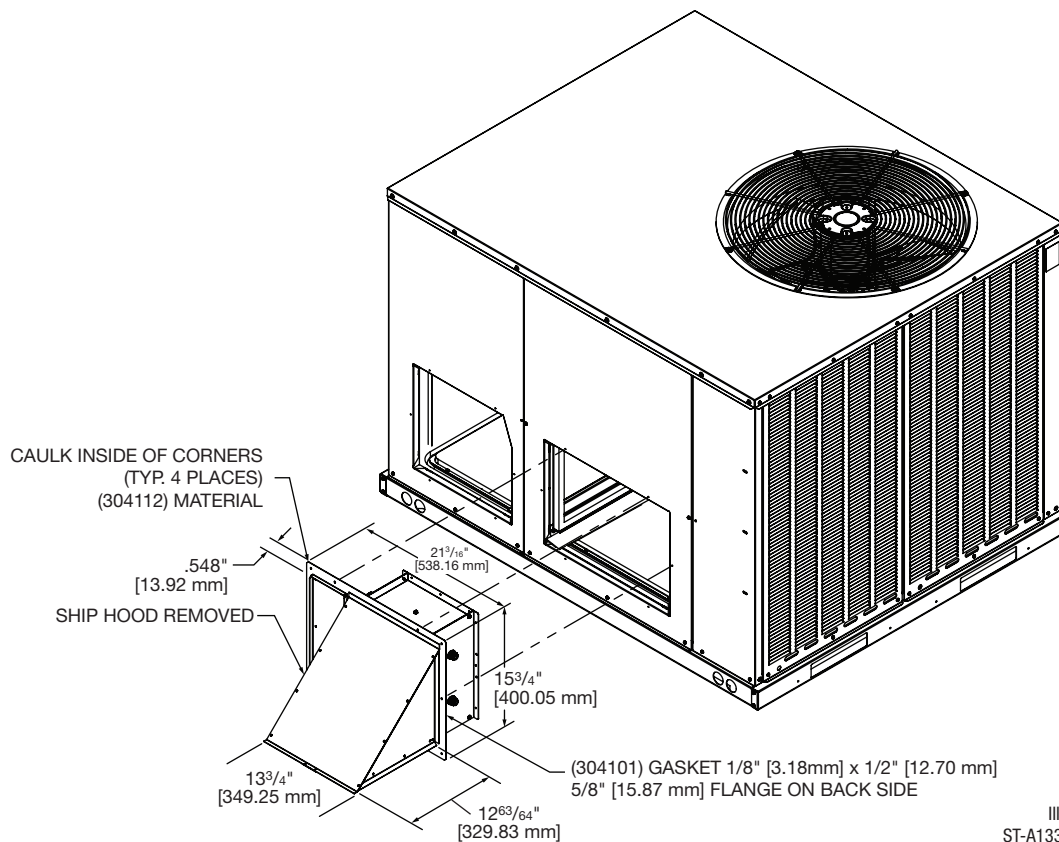

AXRF-FAA2  
AXRF-FAB2

Illustration  
ST-A1334-12-00

[ ] Designates Metric Conversions

## ECONOMIZERS

### AXRD-01RACAM3 (Fully Modulating) Horizontally and Vertically Applicable for the "A" cabinet.

- LCD Screen for Continuous diagnostic and system status
- Programmable set points for accurate positioning
- Simplified wiring and color coded terminals
- Onboard fault detection and diagnostics (FDD)
- Operational Checkout to verify installation
- Enthalpy sensors and actuator that communicate through a Syk Bus Network with the Jade Controller reducing wiring errors while providing more information
- CO2 sensor input for DCV (Demand Control Ventilation) applications
- RXRX-AV04 Dual Enthalpy kit available for field installation
- AMCA licensed class 1A low leak Dampers

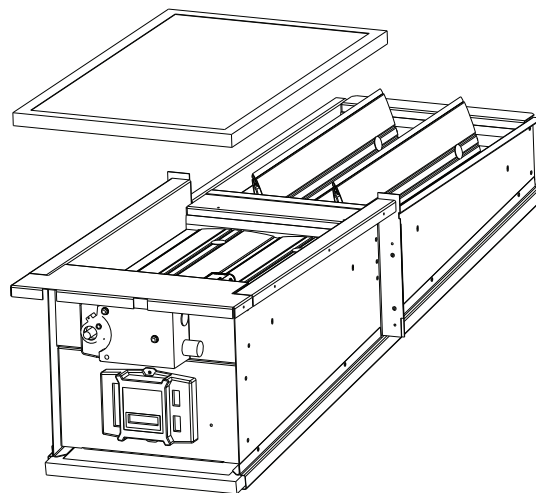
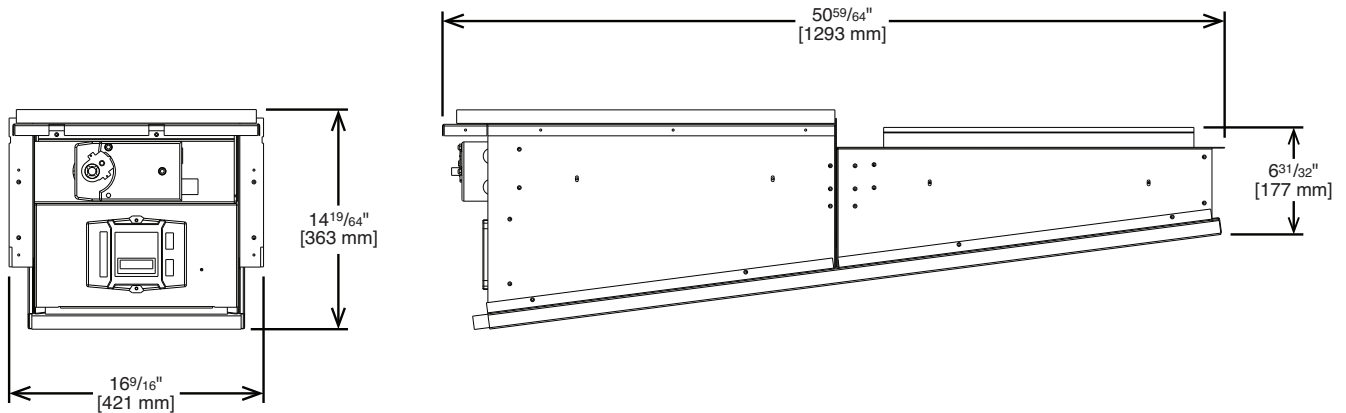
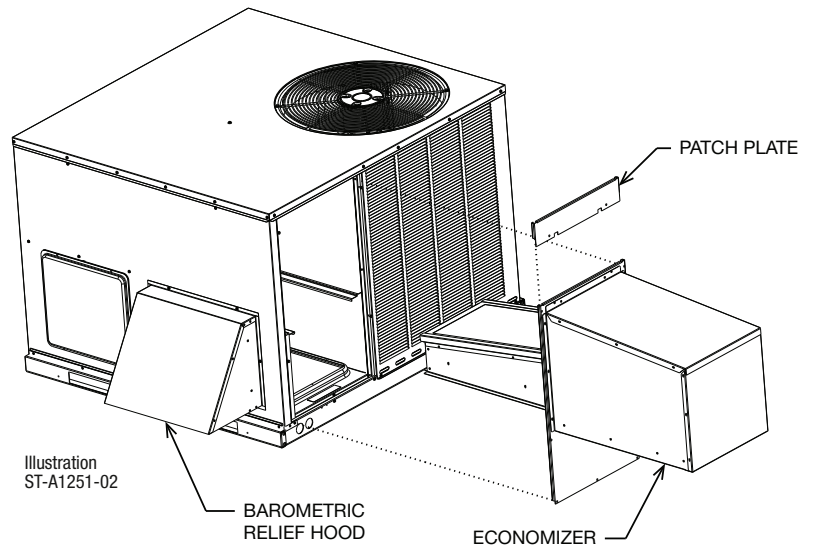

Illustration  
ST-A1251-11

[ ] Designates Metric Conversions

## ECONOMIZERS

### RXRE-11RXCAM3

Horizontally and Vertically Applicable for the "X" cabinet.

- LCD Screen for Continuous diagnostic and system status
- Programmable set points for accurate positioning
- Simplified wiring and color coded terminals
- Onboard fault detection and diagnostics (FDD)
- Operational Checkout to verify installation
- Enthalpy sensors and actuator that communicate with Siemens controller reducing wiring errors while providing more information
- Setup and configure the economizer controller before putting it into usage by using the Climatix Mobile app or the inbuilt display
- CO2 sensor input for demand control ventilation (DCV) applications
- RXRX-BV03 dual enthalpy kit available for field installation
- AMCA licensed class 1A low leak dampers

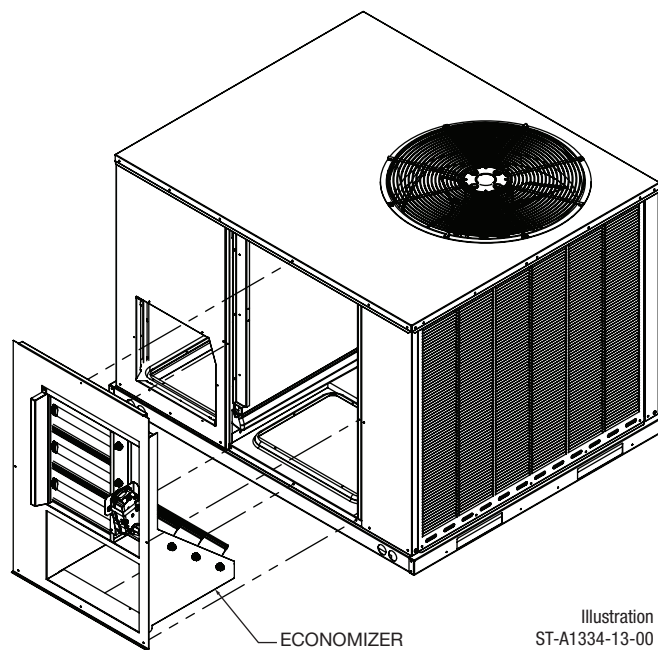

Illustration  
ST-A1334-13-00

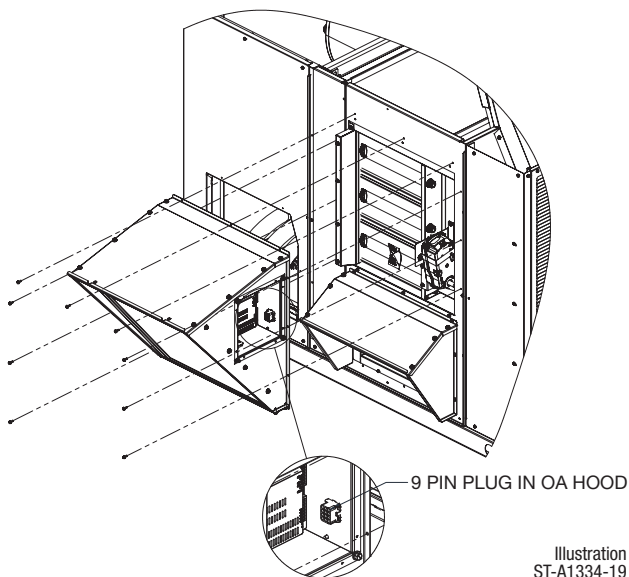
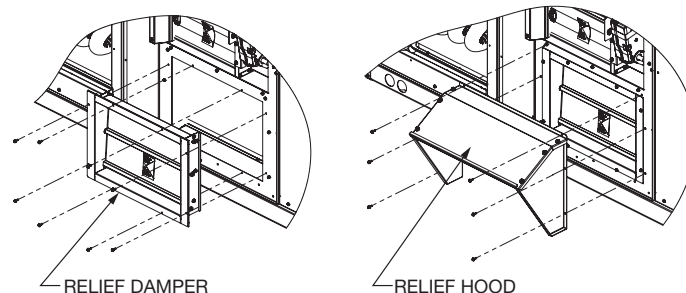

Illustration  
ST-A1334-19

#### VERTICAL APPLICATION



#### HORIZONTAL APPLICATION

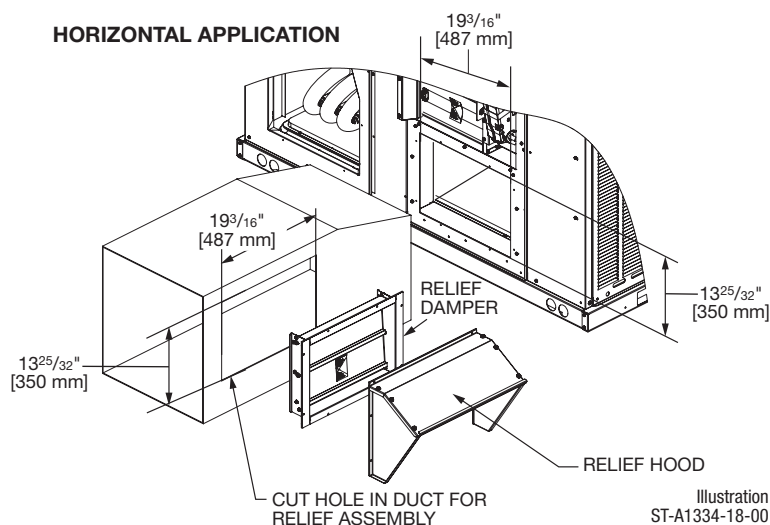

Illustration  
ST-A1334-18-00



## ELECTRIC HEATER KITS - RAC(A/X)ZS

ELECTRIC HEATER KIT MODELS	UNIT MODEL APPLICATION (15.2 SEER2 RAC(A/X)ZS)
RXQJ-A05J (208-240 volt, 1-ph, 5kw)	024/036/048/060*J
RXQJ-A08J (208-240 volt, 1-ph, 8kw)	024/036/048/060*J
RXQJ-A10J (208-240 volt, 1-ph, 10kw)	024/036*J
RXQJ-A15J (208-240 volt, 1-ph, 15kw)	036*J
RXQJ-B10J (208-240 volt, 1-ph, 10kw)	048/060*J
RXQJ-B15J (208-240 volt, 1-ph, 15kw)	048/060*J
RXQJ-A05C (208-240 volt, 3-ph, 5kw)	036/048/060*C
RXQJ-A08C (208-240 volt, 3-ph, 8kw)	036/048/060*C
RXQJ-A10C (208-240 volt, 3-ph, 10kw)	036/048/060*C
RXQJ-A15C (208-240 volt, 3-ph, 15kw)	036/048/060*C
RXQJ-A05D (460 volt, 3-ph, 5kw)	036/048/060*D
RXQJ-A08D (460 volt, 3-ph, 8kw)	036/048/060*D
RXQJ-A10D (460 volt, 3-ph, 10kw)	036/048/060*D
RXQJ-A15D (460 volt, 3-ph, 15kw)	036/048/060*D

### WARNING

ONLY ELECTRIC HEATER KITS SUPPLIED BY THIS MANUFACTURER AS DESCRIBED IN THIS PUBLICATION HAVE BEEN DESIGNED, TESTED, AND EVALUATED BY A NATIONALLY RECOGNIZED SAFETY TESTING AGENCY FOR USE WITH THIS UNIT. USE OF ANY OTHER MANUFACTURED ELECTRIC HEATERS INSTALLED WITHIN THIS UNIT MAY CAUSE HAZARDOUS CONDITIONS RESULTING IN PROPERTY DAMAGE, FIRE, BODILY INJURY OR DEATH.





**BEFORE PURCHASING THIS APPLIANCE, READ IMPORTANT ENERGY COST AND EFFICIENCY INFORMATION AVAILABLE FROM YOUR RETAILER.**

**GENERAL TERMS OF LIMITED WARRANTY\***

Russell® By Rheem will furnish a replacement for any part of this product which fails in normal use and service within the applicable periods stated, in accordance with the terms of the limited warranty.

**\*For complete details of the Limited and Conditional Warranties, including applicable terms and conditions, contact your local contractor or the Manufacturer for a copy of the product warranty certificate.**

**Conditional Parts (Registration Required)**

- 1 Phase, Residential Applications .....Ten (10) Years
- Compressor**
- 1 Phase, Residential Applications .....Ten (10) Years
- 1 & 3 Phase, Commercial Applications .....Five (5) Years
- Parts**
- 1 & 3 Phase, Commercial Applications .....One (1) Year

© 2024 Rheem Manufacturing Company. Russell By Rheem trademarks owned by Rheem Manufacturing Company.

In keeping with its policy of continuous progress and product improvement, Russell by Rheem reserves the right to make changes without notice.



**Russell® By Rheem**  
5600 Old Greenwood Road, Fort Smith, AR 72908

**Before proceeding with installation, refer to installation instructions packaged with each model, as well as complying with all Federal, State, Provincial, and Local codes, regulations, and practices.**