



## Ultra™ Plug-in Heat Pump with HydroBoost and LeakGuard (120V Shared Circuit)

### Efficiency

- Up to 3.46 UEF reduces operating cost
- ENERGY STAR® certified
- Title 24 Compliant (JA13 Ready)

### Performance

- Delivers hot water more efficiently than most standard electric water heaters
- Ambient operating range: 37-145°F is widest in class, offering more days of HP operation annually; designed to meet Northern Climate Spec (NEEA Tier 2)<sup>2</sup>
- Integrated HydroBoost mixing valve maximizes output performance

### Easy Installation

- Easy access side connections
- Factory installed plug-in power cord – plugs directly into a standard wall outlet
- Easily replaces a standard gas water heater

### Integration

- Demand Response Ready – Built-in EcoPort (CTA-2045 Port) allows easy connection to Utility programs
- LED Screen with built-in water sensor alert with audible alarm<sup>1</sup>
- Integrated EcoNet® Wi-Fi-connected<sup>2</sup> technology and free mobile app gives users control over water heater, allowing for customizable temperature, vacation settings, scheduling, energy savings and system monitoring at home or away
- Integrated leak detection and prevention system with factory installed auto water shut-off valve limits leaks to no more than 20 ounces of water<sup>1, 3</sup>

### LEAKGUARD™ WATER SHUT-OFF VALVE

- LeakSense™ Built-in Leak Detection System detects any leak large or small, internal or external<sup>1, 4</sup>

### Operation Modes

- Heat Pump
- Vacation/Away: 2-28 days (or placed on hold indefinitely)

### Plus...

- Premium grade anode rod extends the life of the tank
- 3/4" NPT water inlet and outlet; 3/4" condensate drain connections
- Easy access, top mounted washable air filter
- 2" Non-CFC foam insulation
- Enhanced flow brass drain valve
- Temperature and pressure relief valve installed
- Design certified to NSF/ANSI 372 (Lead Content)

### Warranty

- 10-Year limited tank and parts warranty  
See Residential Warranty Certificate for complete information

Units meet or exceed ANSI requirements and have been tested according to D.O.E. procedures. Units meet or exceed the energy efficiency requirements of NAECA, ASHRAE standard 90, ICC Code and all state energy efficiency performance criteria.

<sup>1</sup>Available with select models. <sup>2</sup>Wi-Fi broadband internet connection required. <sup>3</sup>Source: Ruud Leak-Sensing Data; testing under a vacuum lock using 50-gallon tank, no expansion tank, average tank pressure of 40 psi, assuming no additional faucets are opened. <sup>4</sup>Water leaks from the heater only, as tested across scenarios including a minimum of 5.5mL/hr volume leak rate, using most common installation scenarios.

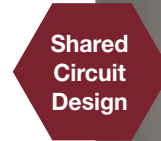

## Ultra Plug-in Heat Pump with HydroBoost and LeakGuard™ (120V Shared Circuit)

40, 50, 65 and 80-Gallon Capacities  
120 Volt / 1 PH Electric



These products meet a stringent set of our internally defined sustainability standards.



LEED Points = 3

See specifications chart on next page.

# Ultra Plug-in Heat Pump with HydroBoost and LeakGuard (120V Shared Circuit) Specifications

DESCRIPTION						ENERGY INFO	FEATURES			TANK DIMENSIONS (SEE SPACE REQUIREMENTS IN DIAGRAMS BELOW)			
NOMINAL GALLON CAPACITY	RATED GALLON CAPACITY	MODEL NUMBER	MODEL VARIANT	ELECTRIC BREAKER SIZE (MINIMUM)	AVERAGE ELECTRICAL WATTAGE	UNIFORM ENERGY FACTOR (UEF)	COMPRESSOR BTU/H	FIRST HR. RATING (GALLONS)	RECOVERY IN G.P.H 60° F RISE	HEIGHT A	DIAM. B	UNIT WT. (LBS)	APPROX. SHIP WT. (LBS.)
40	36	PROUH40 T0 RU120-MSO	700937	15	440W	2.8	4200	45	12	63"	20-1/4"	157	194
50	46	PROUH50 T0 RU120-MSO	700938	15	440W	3.0	4200	55	12	62"	22-1/4"	178	218
65	59	PROUH65 T0 RU120-MSO	700939	15	395W	3.33	4200	63	12	65"	24-1/4"	225	262
80	72	PROUH80 T0 RU120-MSO	700940	15	395W	3.46	4200	84	12	75"	24-1/4"	244	281

Uniform Energy Factor and rated gallon capacity based on Department of Energy (DOE) requirements. All units have integrated Wi-Fi control board.

*\*In cases of fused protection, a time delay fused protection will be required.*

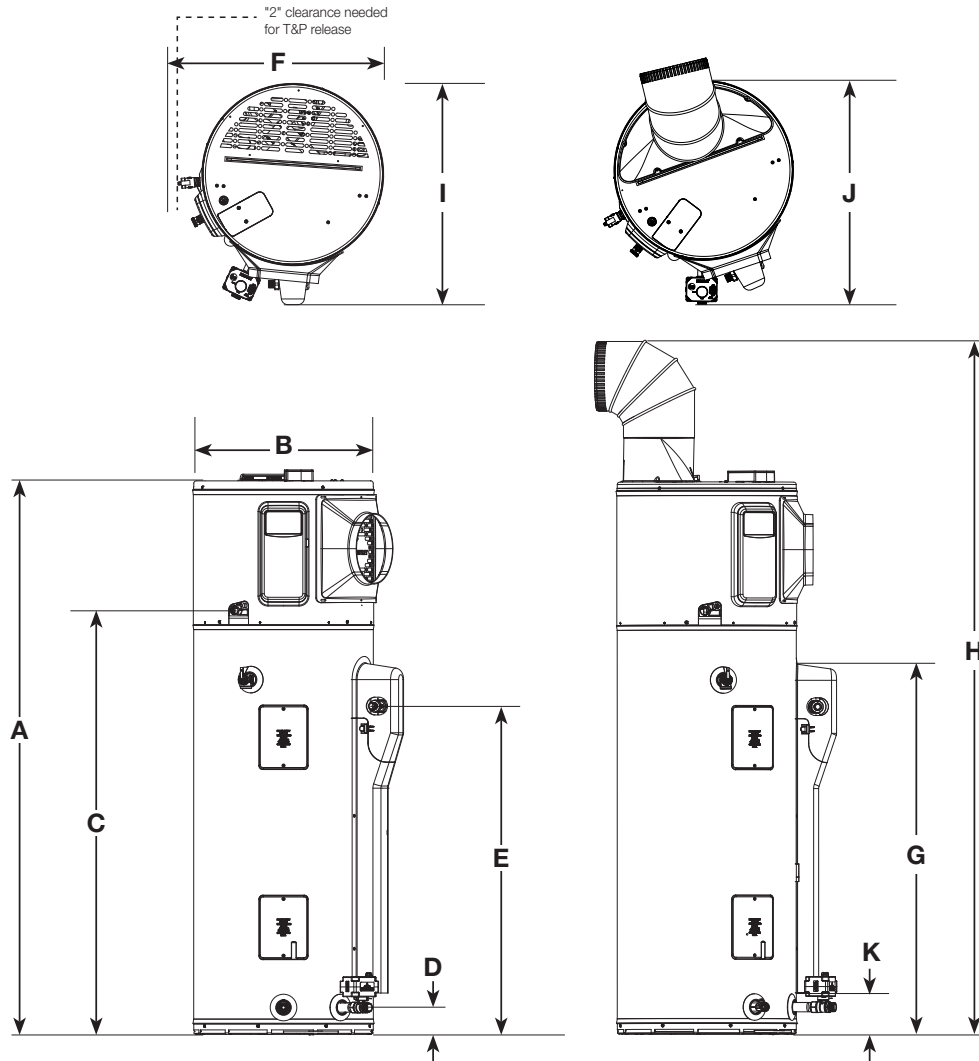

DESCRIPTION		DIMENSIONS (SHOWN IN INCHES)										
NOMINAL GALLON CAPACITY	MODEL NUMBER	A	B	C	D	E	F	G	H	I	J	K
40	PROUH40 T0 RU120-MSO	62-5/16	20-1/4	47	3-5/8	39-5/8	25-3/8	41-7/8	78-7/8	25	23-1/4	4-11/16
50	PROUH50 T0 RU120-MSO	61-3/4	22-1/4	47	3-5/8	39-5/8	27-3/8	41-1/2	78-5/8	27-3/8	25-9/16	4-5/16
65	PROUH65 T0 RU120-MSO	64-3/16	24-1/4	49	3-7/8	42-3/8	29-1/2	44-1-16	81-1/8	29	28-1/16	5
80	PROUH80 T0 RU120-MSO	74-3/16	24-1/4	59	3-7/8	42-3/8	29-1/2	54-5-16	91	29	27-3/8	5-1/16

# Plug-in Heat Pump with HydroBoost Water Heater Installation Guidelines to Provide Optimal Efficiency

## Heater: Not Ducted

Room size: Larger than 700 ft<sup>3</sup>  
(e.g. 7' x 10' x 10').

Requirements:  
No additional  
ventilation needed

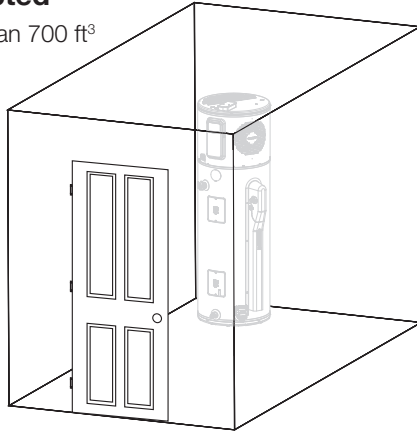

## Heater: Not Ducted

Room size: Smaller than 700 ft<sup>3</sup>  
(e.g. 7' x 10' x 10').

Requirements:  
Full louvered door OR  
two louvers top and  
bottom. See to right.

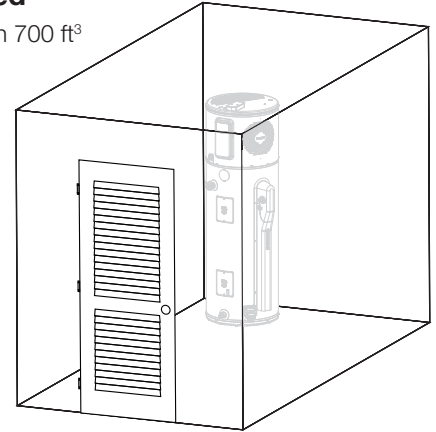

## Heater: Ducted With Inlet or Outlet Duct

Room size:  
Any size room

Requirements: Air gap  
under door equal to  
18 in<sup>2</sup> (0.75" clearance)

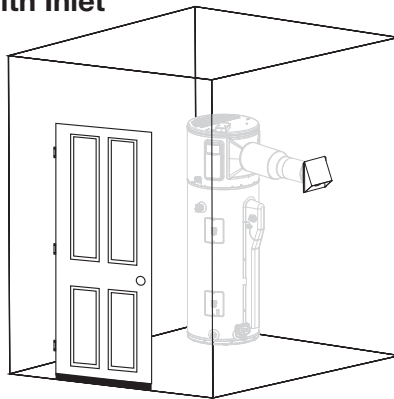

## Heater: Ducted With Inlet and Outlet Duct

Room size:  
Any size room

Requirements:  
No additional  
ventilation needed

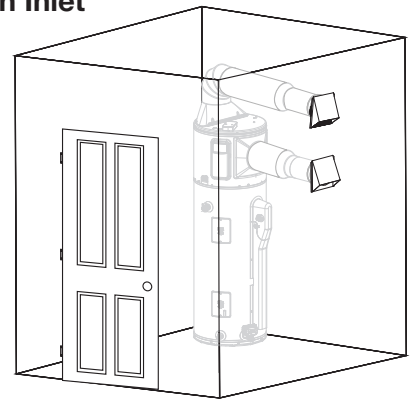

## Notice

If air temperature in installed location drops more than 15°F (8°C) during heating, air circulation is insufficient for efficient operation. Utilize ducting to direct cold exhaust air to another location

**For optimal operation, installation in gray US map zone is recommended. When choosing the proper water heater, consult your local plumbing contractor.**

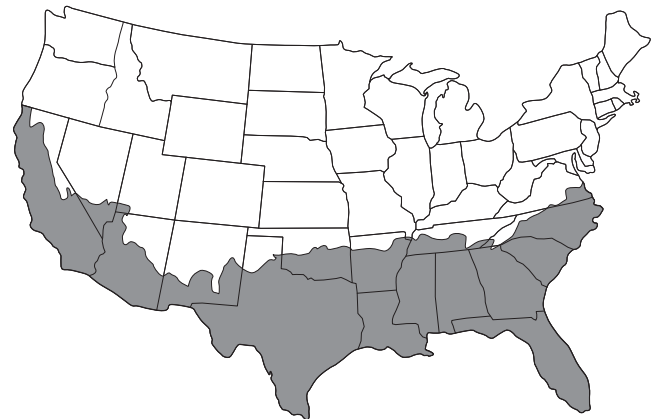
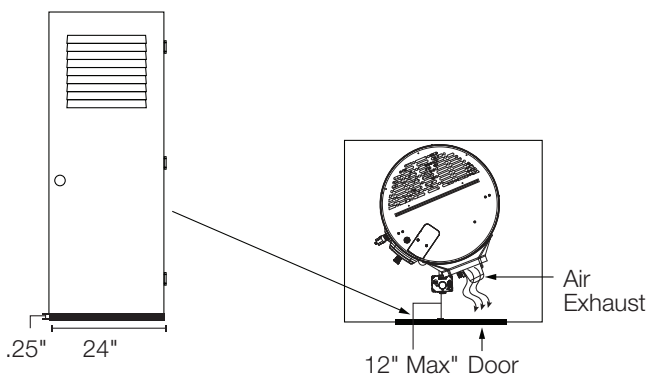

**Average Ambient Air Temp in January**

□ Below 37°F  
■ Above 37°F

## Heater: Not Ducted

Room size: Small Closet

Requirements:

- Air gap under door equals to 18 in<sup>2</sup> (0.75" clearance).
- Louver must be located the same height on door as the air exhaust on heater.
- Heater air exhaust must be positioned towards louver within one foot of door.

MINIMUM CLEARANCES (WITHOUT DUCTING)		
REAR	SIDES	TOP
0"	0"	6"



## Plug-in Heat Pump with HydroBoost Service Parts and Accessories List

PART NUMBER	DESCRIPTION	USE FOR
AP19134	Leak Sensor	Automatic detection of internal and external leaks
AP20180	Shutoff Valve	Automatic shut off of water supply to unit
AP21365	Inlet Duct Adapter	Allows for ducting to be connected on the top inlet
AP17829	Outlet Duct Adapter	Allows for ducting to be connected to the unit
SP20882	Earthquake Isolation Kit	Installations in seismic regions
SP20883	Vibration Isolation Kit	Installation on non-concrete floors
SP20884	8" Diameter UL Certified Termination Kit	Termination to the outside or to the attic with 8" diameter
SP20885	7" Diameter UL Certified Termination Kit	Termination to the outside or to the attic with 7" diameter
SP20886	6" Diameter UL Certified Termination Kit	Termination to the outside or to the attic with 6" diameter
SP20887	5" Diameter UL Certified Termination Kit	Termination to the outside or to the attic with 5" diameter
SP20888	8" Pro Approved Damper Kit	Exhaust only to the outside ducting configuration (no inlet duct)
SP20889	25' Flexible 8" Diameter Duct Kit	For up to 25' of ducting
SP20890	Rigid Elbow Duct Kit	Installation in tight places where space needs to be minimized

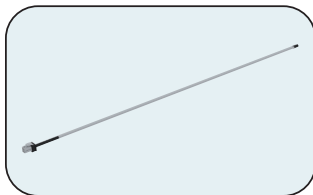

AP19134



AP20180

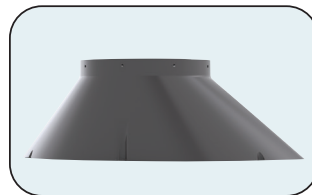

AP21365

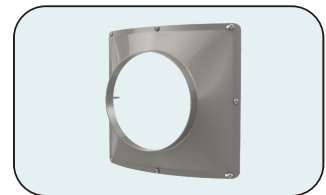

AP17829

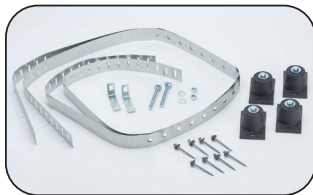

SP20882

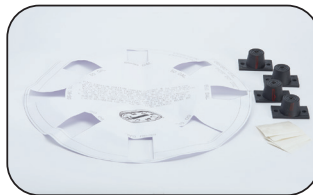

SP20883

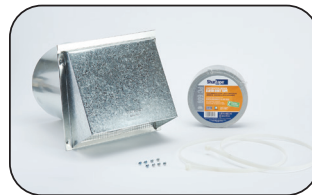

SP20884



SP20885



SP20886



SP20887



SP20888



SP20889



SP20890

*In keeping with its policy of continuous progress and product improvement, Ruud reserves the right to make changes without notice.*