



Vantix™ Line iR Packaged Heat Pump



RHPXZS

Nominal Sizes: 2 to 5 Tons [7.03 to 17.6 kW]

Cooling Efficiency: 15.2 SEER2

Heating Efficiency: 7.2 HSPF2



Table of Contents

Features & Benefits	3
Model Number Identification	4
Dimensional Data	5-6
Typical Installations	7
General Data.....	8-9
General Data Notes	10
Gross Systems Performance Data	11-18
Indoor Airflow Performance.....	19-20
Electrical Data.....	21
Electric Heater Kits.....	22-24
Accessories	25-33
Limited Warranty.....	36

Features and Benefits

- **Two-Stage Scroll Compressor:** For maximum efficiency and quiet operation
- **Louvered Condenser Compartment:** Protects the coil against yard hazards and easily removable for condenser coil cleaning
- **One-piece Top with Drip Flange:** Helps to keep water out of the unit
- **Supply and Return Air Openings:** Feature a one-inch tall flange to prevent water migration into the ductwork
- **Access Panels:** Easily removable and provides access to necessary components for serviceability
- **Side and Down Discharge Options:** Available on all models (Shipped horizontal flow standard)
- **Easily Accessible Blower Section:** Features a slide-out blower
- **Conveniently Located Refrigerant Connections:** For easy service diagnostics. Low pressure/loss of charge protection is standard on all models
- **Evaporator and Condenser Coils:** MicroChannel evaporator coil delivers superior performance with less refrigerant charge and less weight than conventional copper tube/aluminum fin coils
- **Supplemental Electric Heat Strips:** Up to 15 kW are available (field or factory installed) for periods of extreme cold temperatures. Single point wiring simplifies installation
- **Easily Accessible Control Box**
- **Thermal Expansion Valve:** Is standard on all models and provides superior superheat control, reliability, and energy efficiency at all operating conditions
- **Filter Drier:** Is standard on all models
- **Rugged Baserail:** Included for improved installation and handling
- **Reversing Valve Directs Flow of Refrigerant:** And reverses the refrigerant flow when heating is required

Packaged Heat Pumps

<u>R</u>	<u>HP</u>	<u>X</u>	<u>Z</u>	<u>S</u>	<u>024</u>	<u>A</u>	<u>J</u>	<u>T</u>	<u>00</u>	<u>0</u>	<u>N</u>	<u>A</u>
Brand	Product Category	Platform	Refrigerant	Tier	Capacity BTU/HR	Major Series	Voltage	Drive	Electric Heat	Electric Heat Configuration	Control	Minor Series
R - Russell® By Rheem	HP - Heat Pump	X - ResiPack Convertible	Z - R410A	S - Mid Tier (15.2 SEER2)	024 - 24,000 [7.03 kW] 036 - 36,000 [10.55 kW] 048 - 48,000 [14.07 kW] 060 - 60,000 [17.58 kW]	A - 1st Design	J - 1ph, 208-230/60 C - 3ph, 208-230/60	T - Constant Torque	00 - No Electric Heat 10 - 10 Kw Electric Heat 15 - 15 Kw Electric Heat	0 - No Electric Heat 1 - Electric Heat Factory Installed	N - Non-Communicating	A - 1st Design

[] Designates Metric Conversions

Available Models
RHPXZS024AJT000NA
RHPXZS024AJT101NA
RHPXZS036ACT000NA
RHPXZS036ACT101NA
RHPXZS036ACT151NA
RHPXZS036AJT000NA
RHPXZS036AJT101NA
RHPXZS036AJT151NA
RHPXZS048ACT000NA
RHPXZS048ACT151NA
RHPXZS048AJT000NA
RHPXZS048AJT151NA
RHPXZS060ACT000NA
RHPXZS060ACT151NA
RHPXZS060AJT000NA
RHPXZS060AJT151NA

NOTE: Further heater kits available to purchase for field installation.

DIMENSIONAL DATA

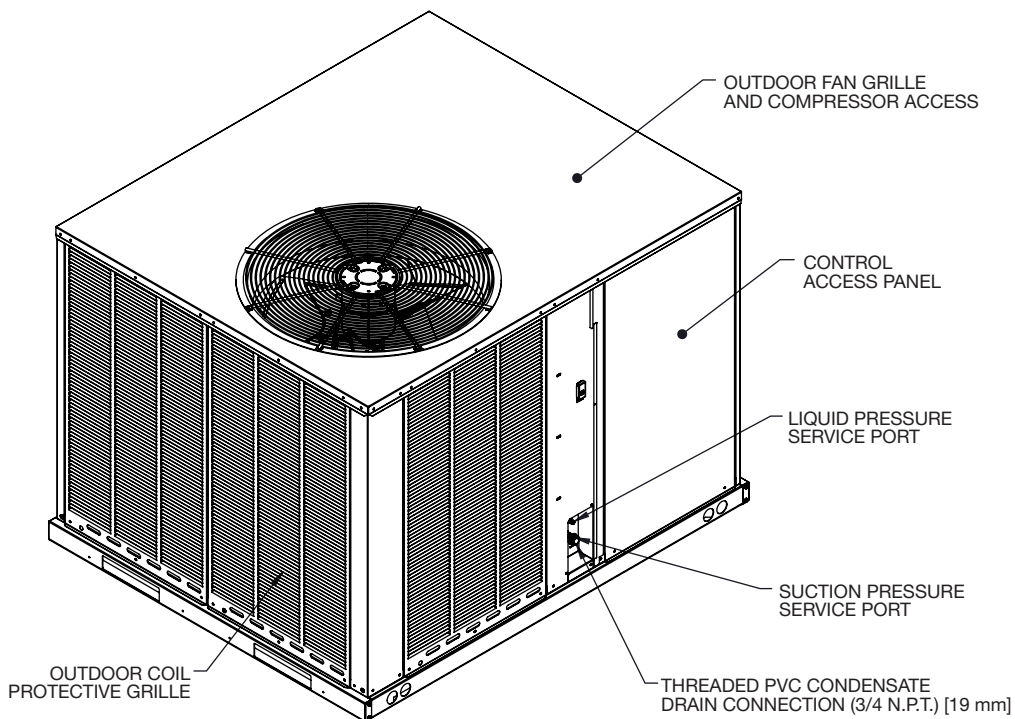
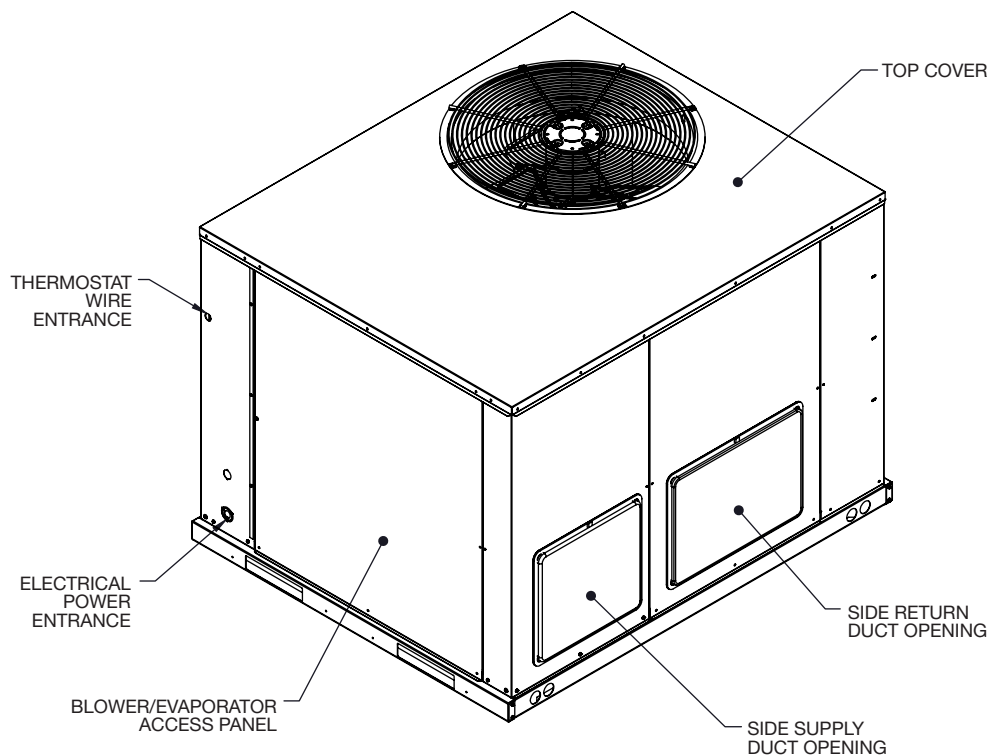

Illustration
ST-A1334-01

[] Designates Metric Conversions

DIMENSIONAL DATA

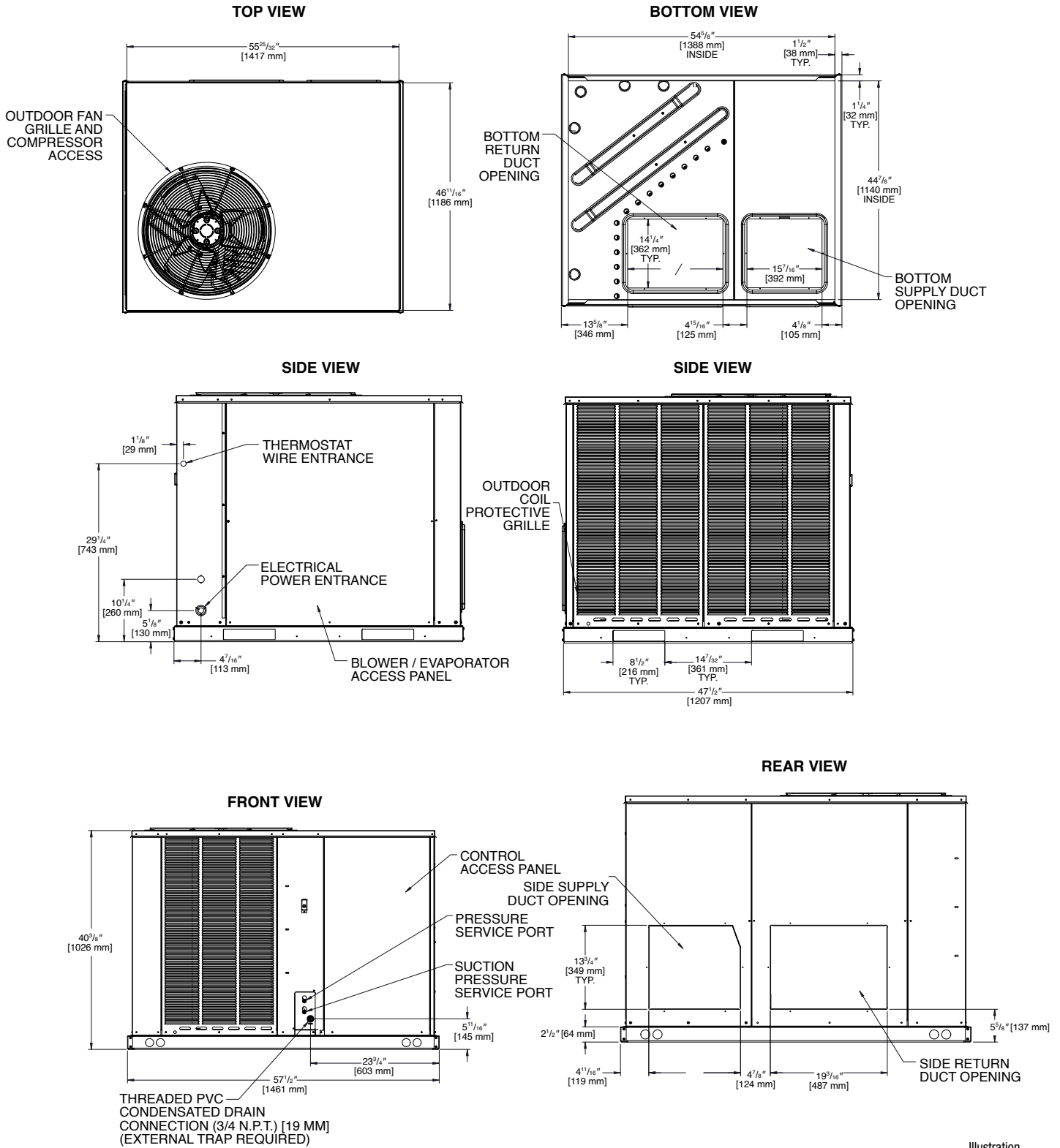
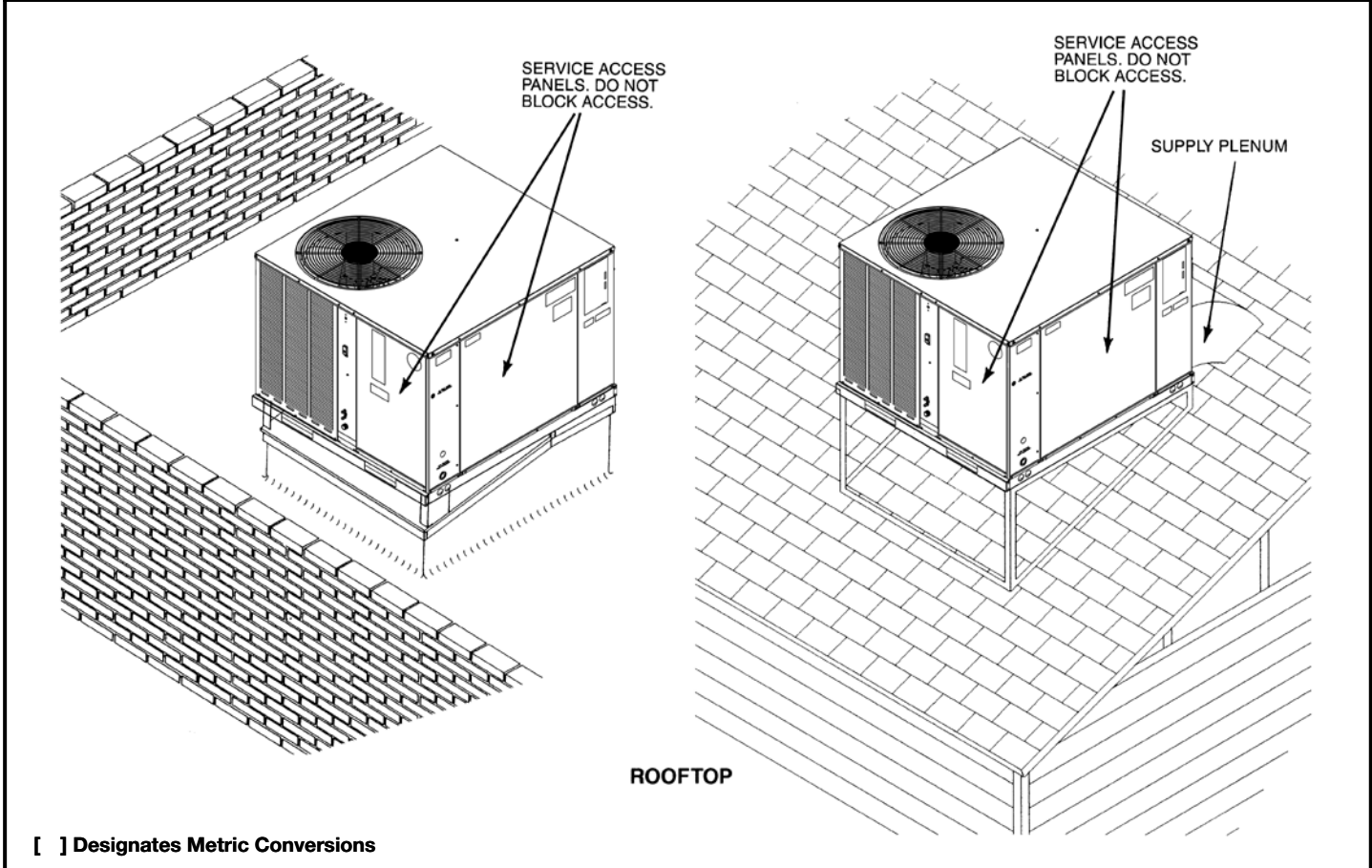
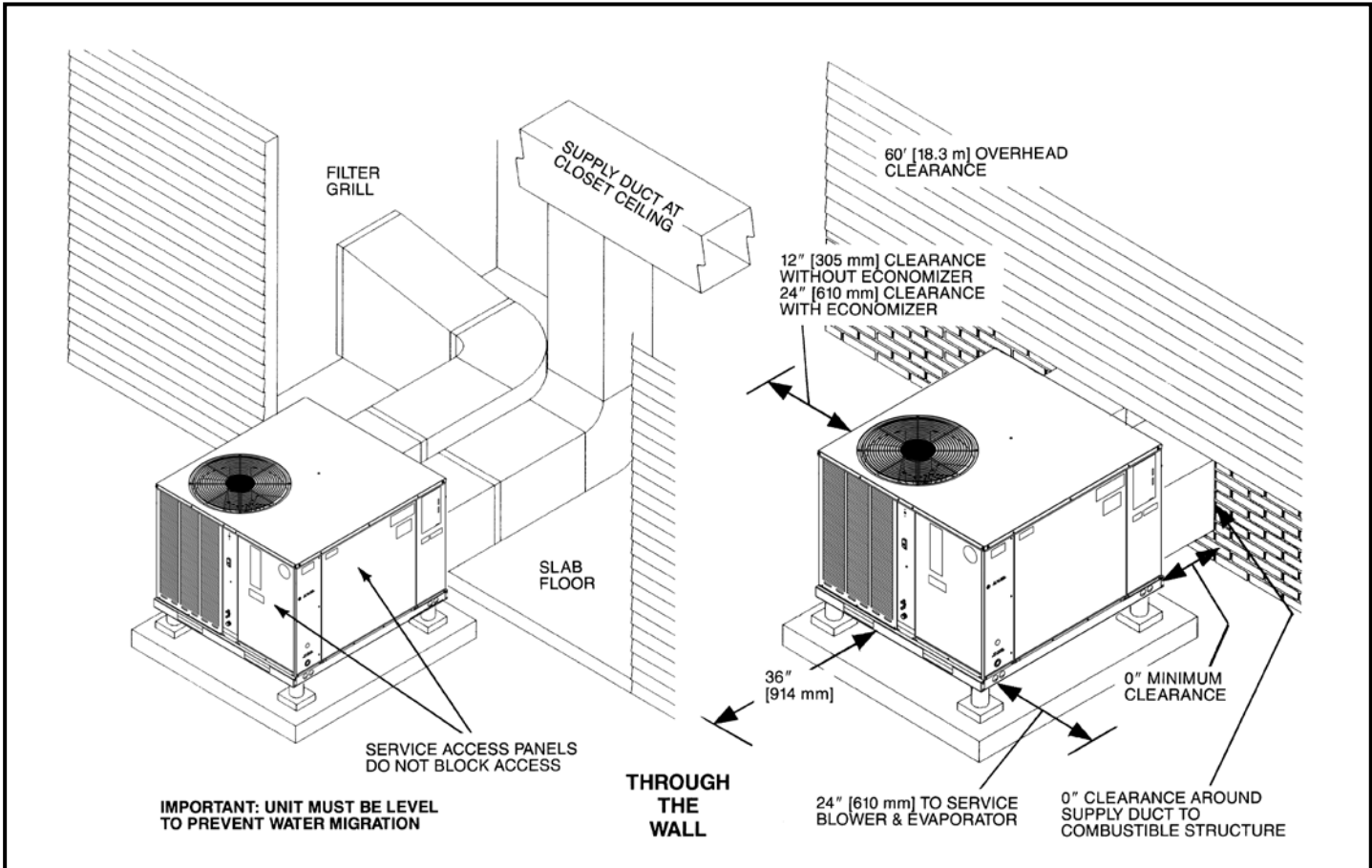

Illustration
ST-A1334-02

[] Designates Metric Conversions



[] Designates Metric Conversions

NOMINAL SIZES 2-5 TONS [7.03-17.6 kW]

Model RHPXZS- Series	RHPXZS024AJT000NA	RHPXZS036ACT000NA	RHPXZS036AJT000NA	RHPXZS048ACT000NA
Cooling Performance¹				CONTINUED →
Nominal Cooling Capacity Btu [kW]	24,000 [7.03]	36,000 [10.55]	36,000 [10.55]	48,000 [14.06]
EER2/SEER2 ²	11.5/15.2	11.5/15.2	11.5/15.2	11.5/15.2
Nominal CFM/AHRI Rated CFM [L/s]	800/850 [378/401]	1200/1200 [566/566]	1200/1200 [566/566]	1600/1470 [755/694]
AHRI Net Cooling Capacity Btu [kW]	23,600 [6.92]	35,000 [10.26]	35,000 [10.26]	47,000 [13.77]
Net Sensible Capacity Btu [kW]	17,600 [5.16]	26,200 [7.68]	26,200 [7.68]	33,700 [9.88]
Net Latent Capacity Btu [kW]	6,000 [1.76]	8,800 [2.58]	8,800 [2.58]	13,300 [3.90]
Net System Power kW	2.05	3.04	3.04	4.09
Heating Performance (Heat Pumps)				
High Temp. Btuh [kW] Rating	22,600 [7.03]	34,000 [9.96]	34,000 [9.96]	45,000 [13.19]
System Power KW/COP	1.74/3.80	2.66/3.75	2.66/3.75	3.52/3.75
Low Temp. Btuh [kW] Rating	14,000 [4.10]	20,200 [5.92]	20,200 [5.92]	29,000 [8.50]
System Power KW/COP	1.71/2.40	2.47/2.40	2.47/2.40	3.43/2.48
HSPF2 ² (Btu/Watts-hr)	7.2	7.2	7.2	7.2
Compressor				
No./Type	1/scroll	1/scroll	1/scroll	1/scroll
Outdoor Sound Rating (dB)³				
	77	80	80	81
Outdoor Coil—Fin Type				
Tube Type	Louvered	Louvered	Louvered	Louvered
MicroChannel Depth in. [mm]	MicroChannel	MicroChannel	MicroChannel	MicroChannel
Face Area sq. ft. [sq. m]	0.63 [16]	0.63 [16]	0.63 [16]	1 [25.4]
Rows/FPI [FPcm]	16 [1.49]	16 [1.49]	16 [1.49]	16 [1.49]
	1 / 16 [6]	1 / 16 [6]	1 / 16 [6]	1 / 16 [6]
Indoor Coil—Fin Type				
Tube Type	Louvered	Louvered	Louvered	Louvered
MicroChannel Depth in. [mm]	MicroChannel	MicroChannel	MicroChannel	MicroChannel
Face Area sq. ft. [sq. m]	1.26 [32]	1 [25.4]	1 [25.4]	1 [25.4]
Rows/FPI [FPcm]	7.08 [0.66]	7.08 [0.66]	7.08 [0.66]	7.08 [0.66]
	1 / 20 [8]	1 / 20 [8]	1 / 20 [8]	1 / 20 [8]
Refrigerant Control	TX Valves	TX Valves	TX Valves	TX Valves
Drain Connection No./Size in. [mm]	1/0.75 [19.05]	1/0.75 [19.05]	1/0.75 [19.05]	1/0.75 [19.05]
Outdoor Fan—Type				
No. Used/Diameter in. [mm]	Propeller	Propeller	Propeller	Propeller
Drive Type/No. Speeds	1/24 [609.6]	1/24 [609.6]	1/24 [609.6]	1/24 [609.6]
CFM [L/s]	Direct/1	Direct/1	Direct/1	Direct/1
No. Motors/HP	3650 [1722]	4500 [2173]	4500 [2173]	4200 [1982]
Motor RPM	1 at 1/6	1 at 1/3 HP	1 at 1/3 HP	1 at 1/3 HP
	850	825	825	825
Indoor Fan—Type				
No. Used/Diameter in. [mm]	FC Centrifugal	FC Centrifugal	FC Centrifugal	FC Centrifugal
Drive Type	1/12x9 [305x229]	1/12x9 [305x229]	1/12x9 [305x229]	1/12x9 [305x229]
No. Speeds	Direct	Direct	Direct	Direct
No. Motors	Multiple	Multiple	Multiple	Multiple
Motor HP	1	1	1	1
Motor RPM	1/3	1/2	1/2	3/4
Motor Frame Size	1075	1075	1075	1075
	48	48	48	48
Filter—Type				
Furnished	Field Supplied	Field Supplied	Field Supplied	Field Supplied
(NO.) Size Recommended in. [mm x mm x mm]	No	No	No	No
	(2)1x16x30 [25x406x762]	(2)1x16x30 [25x406x762]	(2)1x16x30 [25x406x762]	(2)1x16x30 [25x406x762]
Refrigerant Charge Oz. [g]				
	94.4 [2665]	80.0 [2268]	80.0 [2268]	132.8 [3760]
Weights				
Net Weight lbs. [kg]	443 [201]	439 [199]	439 [199]	485 [220]
Ship Weight lbs. [kg]	453 [206]	449 [204]	449 [204]	495 [225]

See Page 10 for Notes.

[] Designates Metric Conversions

NOMINAL SIZES 2-5 TONS [7.03-17.6 kW]

Model RHPXZS- Series	RHPXZS048AJT000NA	RHPXZS060ACT000NA	RHPXZS060AJT000NA
Cooling Performance¹			
Nominal Cooling Capacity Btu [kW]	48,000 [14.06]	60,000 [17.58]	60,000 [17.58]
EER2/SEER2 ²	11.5/15.2	11.5/15.2	11.5/15.2
Nominal CFM/AHRI Rated CFM [L/s]	1600/1470 [755/694]	2000/1825 [944/861]	2000/1825 [944/861]
AHRI Net Cooling Capacity Btu [kW]	47,000 [13.77]	58,000 [17.00]	58,000 [17.00]
Net Sensible Capacity Btu [kW]	33,700 [9.88]	42,300 [12.40]	42,300 [12.40]
Net Latent Capacity Btu [kW]	13,300 [3.90]	15,700 [4.60]	15,700 [4.60]
Net System Power kW	4.09	5.04	5.04
Heating Performance (Heat Pumps)			
High Temp. Btuh [kW] Rating	45,000 [13.19]	56,000 [16.41]	56,000 [16.41]
System Power KW/COP	3.52/3.75	4.38/3.75	4.38/3.75
Low Temp. Btuh [kW] Rating	29,000 [8.50]	35,200 [10.32]	35,200 [10.32]
System Power KW/COP	3.43/2.48	4.09/2.52	4.09/2.52
HSPF2 ² (Btu/Watts-hr)	7.2	7.2	7.2
Compressor			
No./Type	1/scroll	1/scroll	1/scroll
Outdoor Sound Rating (dB)³			
	81	77	77
Outdoor Coil—Fin Type			
	Louvered	Louvered	Louvered
Tube Type	MicroChannel	MicroChannel	MicroChannel
MicroChannel Depth in. [mm]	1 [25.4]	1.26 [32]	1.26 [32]
Face Area sq. ft. [sq. m]	16 [1.49]	16 [1.49]	16 [1.49]
Rows/FPI [FPcm]	1 / 16 [6]	1 / 16 [6]	1 / 16 [6]
Indoor Coil—Fin Type			
	Louvered	Louvered	Louvered
Tube Type	MicroChannel	MicroChannel	MicroChannel
MicroChannel Depth in. [mm]	1 [25.4]	1.26 [32]	1.26 [32]
Face Area sq. ft. [sq. m]	7.08 [0.66]	7.08 [0.66]	7.08 [0.66]
Rows/FPI [FPcm]	1 / 20 [8]	1 / 20 [8]	1 / 20 [8]
Refrigerant Control	TX Valves	TX Valves	TX Valves
Drain Connection No./Size in. [mm]	1/0.75 [19.05]	1/0.75 [19.05]	1/0.75 [19.05]
Outdoor Fan—Type			
	Propeller	Propeller	Propeller
No. Used/Diameter in. [mm]	1/24 [609.6]	1/24 [609.6]	1/24 [609.6]
Drive Type/No. Speeds	Direct/1	Direct/2	Direct/2
CFM [L/s]	4200 [1982]	4200 [1982]	4200 [1982]
No. Motors/HP	1 at 1/3 HP	1 at 1/2	1 at 1/2
Motor RPM	825	740/935	740/935
Indoor Fan—Type			
	FC Centrifugal	FC Centrifugal	FC Centrifugal
No. Used/Diameter in. [mm]	1/12x9 [305x229]	1/12x9 [305x229]	1/12x9 [305x229]
Drive Type	Direct	Direct	Direct
No. Speeds	Multiple	Multiple	Multiple
No. Motors	1	1	1
Motor HP	3/4	1	1
Motor RPM	1075	1050	1050
Motor Frame Size	48	48	48
Filter—Type			
	Field Supplied	Field Supplied	Field Supplied
Furnished	No	No	No
(NO.) Size Recommended in. [mm x mm x mm]	(2)1x16x30 [25x406x762]	(2)1x16x30 [25x406x762]	(2)1x16x30 [25x406x762]
Refrigerant Charge Oz. [g]			
	132.8 [3760]	156.8 [4445]	156.8 [4445]
Weights			
Net Weight lbs. [kg]	485 [220]	502 [232]	502 [232]
Ship Weight lbs. [kg]	495 [225]	512 [237]	512 [237]

See Page 10 for Notes.

[] Designates Metric Conversions

NOTES:

1. Cooling Performance is rated at 95°F ambient, 80°F entering dry bulb, 67°F entering wet bulb. Gross capacity does not include the effect of fan motor heat. AHRI capacity is net and includes the effect of fan motor heat. Units are suitable for operation to $\pm 20\%$ of nominal cfm. Units are certified in accordance with the Unitary Air Conditioner Equipment certification program, which is based on AHRI Standard 210/240 or 360.
2. EER2/SEER2 and HSPF2 are rated at AHRI conditions and in accordance with DOE test procedures.
3. Outdoor Sound Rating shown is tested in accordance with AHRI Standard 270.

COOLING PERFORMANCE DATA—RHPXZS024

		ENTERING INDOOR AIR @ 80°F [26.7°C] dbE ①									
		71°F [21.7°C]			67°F [19.4°C]			63°F [17.2°C]			
wbE		975 [460]	850 [401]	700 [330]	975 [460]	850 [401]	700 [330]	975 [460]	850 [401]	700 [330]	
CFM [L/s]		975 [460]	850 [401]	700 [330]	975 [460]	850 [401]	700 [330]	975 [460]	850 [401]	700 [330]	
DR ①		.05	.09	.12	.05	.09	.12	.05	.09	.12	
OUTDOOR DRY BULB TEMPERATURE	75 [23.9]	Total BTUH [kW] Sens BTUH [kW] Power	33.3 [9.8] 19.7 [5.8] 1.6	32.5 [9.5] 18.5 [5.4] 1.6	31.4 [9.2] 16.9 [5.0] 1.6	30.7 [9.0] 23.3 [6.8] 1.6	29.9 [8.8] 21.8 [6.4] 1.6	28.9 [8.5] 20.0 [5.9] 1.6	28.8 [8.4] 27.5 [8.1] 1.6	28.0 [8.2] 25.8 [7.6] 1.6	27.1 [7.9] 23.6 [6.9] 1.6
	80 [26.7]	Total BTUH [kW] Sens BTUH [kW] Power	32.4 [9.5] 19.3 [5.7] 1.7	31.5 [9.2] 18.0 [5.3] 1.7	30.5 [8.9] 16.5 [4.8] 1.7	29.7 [8.7] 22.8 [6.7] 1.7	29.0 [8.5] 21.3 [6.2] 1.7	28.0 [8.2] 19.6 [5.7] 1.7	27.8 [8.1] 27.1 [7.9] 1.7	27.1 [7.9] 25.3 [7.4] 1.7	26.2 [7.7] 23.2 [6.8] 1.7
	85 [29.4]	Total BTUH [kW] Sens BTUH [kW] Power	31.4 [9.2] 18.8 [5.5] 1.8	30.6 [9.0] 17.6 [5.2] 1.8	29.6 [8.7] 16.1 [4.7] 1.8	28.7 [8.4] 22.3 [6.5] 1.8	28.0 [8.2] 20.9 [6.1] 1.8	27.1 [7.9] 19.2 [5.6] 1.8	26.8 [7.9] 26.6 [7.8] 1.8	26.1 [7.6] 24.9 [7.3] 1.8	25.3 [7.4] 22.8 [6.7] 1.8
	90 [32.2]	Total BTUH [kW] Sens BTUH [kW] Power	30.4 [8.9] 18.3 [5.4] 1.9	29.6 [8.7] 17.1 [5.0] 1.9	28.6 [8.4] 15.7 [4.6] 1.8	27.7 [8.1] 21.8 [6.4] 1.9	27.0 [7.9] 20.4 [6.0] 1.9	26.1 [7.6] 18.7 [5.5] 1.8	25.8 [7.6] 25.8 [7.6] 1.9	25.1 [7.4] 24.4 [7.2] 1.9	24.3 [7.1] 22.4 [6.6] 1.8
	95 [35.0]	Total BTUH [kW] Sens BTUH [kW] Power	29.3 [8.6] 17.8 [5.2] 2.0	28.6 [8.4] 16.6 [4.9] 2.0	27.6 [8.1] 15.3 [4.5] 1.9	26.7 [7.8] 21.3 [6.2] 2.0	26.0 [7.6] 19.9 [5.8] 2.0	25.1 [7.4] 18.3 [5.4] 1.9	24.7 [7.2] 24.7 [7.2] 2.0	24.1 [7.1] 23.9 [7.0] 2.0	23.3 [6.8] 22.0 [6.4] 1.9
	100 [37.8]	Total BTUH [kW] Sens BTUH [kW] Power	28.3 [8.3] 17.2 [5.0] 2.1	27.5 [8.1] 16.1 [4.7] 2.1	26.6 [7.8] 14.8 [4.3] 2.0	25.6 [7.5] 20.8 [6.1] 2.1	25.0 [7.3] 19.4 [5.7] 2.1	24.2 [7.1] 17.8 [5.2] 2.0	23.7 [6.9] 23.7 [6.9] 2.1	23.1 [6.8] 23.1 [6.8] 2.1	22.3 [6.5] 21.5 [6.3] 2.0
	105 [40.6]	Total BTUH [kW] Sens BTUH [kW] Power	27.2 [8.0] 16.7 [4.9] 2.2	26.5 [7.8] 15.6 [4.6] 2.2	25.6 [7.5] 14.3 [4.2] 2.1	24.5 [7.2] 20.2 [5.9] 2.2	23.9 [7.0] 18.9 [5.5] 2.2	23.1 [6.8] 17.3 [5.1] 2.1	22.6 [6.6] 22.6 [6.6] 2.2	22.0 [6.4] 22.0 [6.4] 2.2	21.3 [6.2] 21.0 [6.2] 2.1
	110 [43.3]	Total BTUH [kW] Sens BTUH [kW] Power	26.1 [7.6] 16.1 [4.7] 2.3	25.4 [7.4] 15.1 [4.4] 2.3	24.6 [7.2] 13.8 [4.0] 2.3	23.5 [6.9] 19.6 [5.7] 2.3	22.8 [6.7] 18.4 [5.4] 2.3	22.1 [6.5] 16.9 [5.0] 2.3	21.5 [6.3] 21.5 [6.3] 2.3	21.0 [6.2] 21.0 [6.2] 2.3	20.3 [5.9] 20.3 [5.9] 2.3
	115 [46.1]	Total BTUH [kW] Sens BTUH [kW] Power	25.0 [7.3] 15.5 [4.5] 2.4	24.3 [7.1] 14.5 [4.2] 2.4	23.6 [6.9] 13.3 [3.9] 2.4	22.3 [6.5] 19.0 [5.6] 2.4	21.8 [6.4] 17.8 [5.2] 2.4	21.1 [6.2] 16.3 [4.8] 2.4	20.4 [6.0] 20.4 [6.0] 2.4	19.9 [5.8] 19.9 [5.8] 2.4	19.2 [5.6] 19.2 [5.6] 2.4
	120 [48.9]	Total BTUH [kW] Sens BTUH [kW] Power	23.9 [7.0] 14.9 [4.4] 2.6	23.2 [6.8] 13.9 [4.1] 2.5	22.5 [6.6] 12.8 [3.8] 2.5	21.2 [6.2] 18.4 [5.4] 2.6	20.7 [6.1] 17.2 [5.0] 2.5	20.0 [5.9] 15.8 [4.6] 2.5	19.3 [5.7] 19.3 [5.7] 2.6	18.8 [5.5] 18.8 [5.5] 2.5	18.2 [5.3] 18.2 [5.3] 2.5
	125 [51.7]	Total BTUH [kW] Sens BTUH [kW] Power	22.7 [6.7] 14.2 [4.2] 2.7	22.1 [6.5] 13.3 [3.9] 2.7	21.4 [6.3] 12.2 [3.6] 2.6	20.1 [5.9] 17.8 [5.2] 2.7	19.5 [5.7] 16.6 [4.9] 2.7	18.9 [5.5] 15.3 [4.5] 2.6	18.1 [5.3] 18.1 [5.3] 2.7	17.7 [5.2] 17.7 [5.2] 2.7	17.1 [5.0] 17.1 [5.0] 2.6

DR —Depression ratio
dbE —Entering air dry bulb
wbE—Entering air wet bulb

Total —Total capacity x 1000 BTUH
Sens —Sensible capacity x 1000 BTUH
Power—KW input

NOTES:

① When the entering air dry bulb is other than 80°F [27°C], adjust the sensible capacity from the table by adding [1.10 x CFM x (1 – DR) x (dbE – 80)].

[] Designates Metric Conversions

HEATING PERFORMANCE DATA—RHPXZS024

IDB		60°F [15.5°C]			70°F [21.1°C]			80°F [26.7°C]			
		CFM [L/s]	900 [425]	850 [401]	650 [307]	900 [425]	850 [401]	650 [307]	900 [425]	850 [401]	650 [307]
O U T D O O R D R Y B U L B T E M P E R A T U R E	0 [-17.8]	Total BTUH [kW] Power	8.4 [2.5] 1.4	8.3 [2.4] 1.4	8.2 [2.4] 1.5	8.7 [2.5] 1.6	8.7 [2.5] 1.6	8.5 [2.5] 1.7	9.1 [2.7] 1.8	9.0 [2.6] 1.8	8.9 [2.6] 1.9
	5 [-15]	Total BTUH [kW] Power	10.0 [2.9] 1.4	10.0 [2.9] 1.5	9.8 [2.9] 1.5	10.4 [3.0] 1.6	10.3 [3.0] 1.6	10.1 [3.0] 1.7	10.7 [3.1] 1.8	10.6 [3.1] 1.9	10.5 [3.1] 1.9
	10 [-12.2]	Total BTUH [kW] Power	11.7 [3.4] 1.5	11.6 [3.4] 1.5	11.4 [3.3] 1.5	12.0 [3.5] 1.7	11.9 [3.5] 1.7	11.7 [3.4] 1.7	12.3 [3.6] 1.9	12.3 [3.6] 1.9	12.1 [3.5] 1.9
	15 [-9.4]	Total BTUH [kW] Power	13.3 [3.9] 1.5	13.2 [3.9] 1.5	13.0 [3.8] 1.5	13.6 [4.0] 1.7	13.6 [4.0] 1.7	13.3 [3.9] 1.7	14.0 [4.1] 1.9	13.9 [4.1] 1.9	13.7 [4.0] 2.0
	20 [-6.7]	Total BTUH [kW] Power	14.9 [4.4] 1.5	14.9 [4.4] 1.5	14.6 [4.3] 1.6	15.3 [4.5] 1.7	15.2 [4.5] 1.7	15.0 [4.4] 1.8	15.6 [4.6] 1.9	15.5 [4.5] 1.9	15.3 [4.5] 2.0
	25 [-3.9]	Total BTUH [kW] Power	16.6 [4.9] 1.5	16.5 [4.8] 1.5	16.2 [4.7] 1.6	16.9 [5.0] 1.7	16.8 [4.9] 1.7	16.6 [4.9] 1.8	17.2 [5.0] 1.9	17.2 [5.0] 1.9	16.9 [5.0] 2.0
	30 [-1.1]	Total BTUH [kW] Power	18.2 [5.3] 1.6	18.1 [5.3] 1.6	17.8 [5.2] 1.6	18.5 [5.4] 1.7	18.5 [5.4] 1.8	18.2 [5.3] 1.8	18.9 [5.5] 2.0	18.8 [5.5] 2.0	18.5 [5.4] 2.0
	35 [1.7]	Total BTUH [kW] Power	19.9 [5.8] 1.6	19.8 [5.8] 1.6	19.4 [5.7] 1.6	20.2 [5.9] 1.8	20.1 [5.9] 1.8	19.8 [5.8] 1.8	20.5 [6.0] 2.0	20.4 [6.0] 2.0	20.1 [5.9] 2.1
	40 [4.4]	Total BTUH [kW] Power	21.5 [6.3] 1.6	21.4 [6.3] 1.6	21.0 [6.2] 1.7	21.8 [6.4] 1.8	21.7 [6.4] 1.8	21.4 [6.3] 1.9	22.2 [6.5] 2.0	22.1 [6.5] 2.0	21.7 [6.4] 2.1
	45 [7.2]	Total BTUH [kW] Power	23.1 [6.8] 1.6	23.0 [6.7] 1.6	22.6 [6.6] 1.7	23.5 [6.9] 1.8	23.4 [6.9] 1.8	23.0 [6.7] 1.9	23.8 [7.0] 2.0	23.7 [6.9] 2.0	23.3 [6.8] 2.1
50 [10.0]	Total BTUH [kW] Power	24.8 [7.3] 1.6	24.7 [7.2] 1.7	24.2 [7.1] 1.7	25.1 [7.4] 1.8	25.0 [7.3] 1.9	24.6 [7.2] 1.9	25.4 [7.4] 2.0	25.3 [7.4] 2.1	24.9 [7.3] 2.1	

IDB—Indoor air dry bulb

[] Designates Metric Conversions

COOLING PERFORMANCE DATA—RHPXZS036

		ENTERING INDOOR AIR @ 80°F [26.7°C] dbE ①									
		wbE	71°F [21.7°C]			67°F [19.4°C]			63°F [17.2°C]		
		CFM [L/s]	1375 [649]	1200 [566]	975 [460]	1375 [649]	1200 [566]	975 [460]	1375 [649]	1200 [566]	975 [460]
DR ①		.05	.09	.12	.05	.09	.12	.05	.09	.12	
OUTDOOR DRY BULB TEMPERATURE °F [°C]	75 [23.9]	Total BTUH [kW]	44.3 [13.0]	43.2 [12.7]	41.7 [12.2]	41.6 [12.2]	40.5 [11.9]	39.1 [11.5]	38.9 [11.4]	37.9 [11.1]	36.6 [10.7]
		Sens BTUH [kW]	26.0 [7.6]	24.4 [7.2]	22.2 [6.5]	31.1 [9.1]	29.1 [8.5]	26.5 [7.8]	36.2 [10.6]	33.9 [9.9]	30.9 [9.1]
		Power	2.5	2.5	2.5	2.5	2.5	2.4	2.5	2.4	2.4
	80 [26.7]	Total BTUH [kW]	43.4 [12.7]	42.3 [12.4]	40.8 [12.0]	40.6 [11.9]	39.6 [11.6]	38.2 [11.2]	38.0 [11.1]	37.0 [10.8]	35.7 [10.5]
		Sens BTUH [kW]	25.7 [7.5]	24.0 [7.0]	21.9 [6.4]	30.7 [9.0]	28.7 [8.4]	26.2 [7.7]	35.8 [10.5]	33.5 [9.8]	30.6 [9.0]
		Power	2.6	2.6	2.6	2.6	2.6	2.5	2.6	2.5	2.5
	85 [29.4]	Total BTUH [kW]	42.4 [12.4]	41.3 [12.1]	39.9 [11.7]	39.6 [11.6]	38.6 [11.3]	37.3 [10.9]	36.9 [10.8]	36.0 [10.6]	34.8 [10.2]
		Sens BTUH [kW]	25.2 [7.4]	23.6 [6.9]	21.6 [6.3]	30.3 [8.9]	28.3 [8.3]	25.9 [7.6]	35.4 [10.4]	33.1 [9.7]	30.2 [8.9]
		Power	2.8	2.7	2.7	2.7	2.7	2.6	2.7	2.7	2.6
	90 [32.2]	Total BTUH [kW]	41.3 [12.1]	40.2 [11.8]	38.8 [11.4]	38.5 [11.3]	37.5 [11.0]	36.2 [10.6]	35.8 [10.5]	34.9 [10.2]	33.7 [9.9]
		Sens BTUH [kW]	24.7 [7.2]	23.2 [6.8]	21.1 [6.2]	29.8 [8.7]	27.9 [8.2]	25.4 [7.4]	34.9 [10.2]	32.7 [9.6]	29.8 [8.7]
		Power	2.9	2.8	2.8	2.8	2.8	2.8	2.8	2.8	2.7
95 [35.0]	Total BTUH [kW]	40.1 [11.8]	39.1 [11.5]	37.7 [11.0]	37.3 [10.9]	36.4 [10.7]	35.1 [10.3]	34.7 [10.2]	33.8 [9.9]	32.6 [9.6]	
	Sens BTUH [kW]	24.2 [7.1]	22.6 [6.6]	20.6 [6.0]	29.2 [8.6]	27.3 [8.0]	24.9 [7.3]	34.3 [10.1]	32.1 [9.4]	29.3 [8.6]	
	Power	3.0	3.0	2.9	3.0	2.9	2.9	2.9	2.9	2.9	
100 [37.8]	Total BTUH [kW]	38.9 [11.4]	37.9 [11.1]	36.6 [10.7]	36.1 [10.6]	35.2 [10.3]	34.0 [10.0]	33.5 [9.8]	32.6 [9.6]	31.5 [9.2]	
	Sens BTUH [kW]	23.5 [6.9]	22.0 [6.4]	20.1 [5.9]	28.5 [8.4]	26.7 [7.8]	24.4 [7.2]	33.5 [9.8]	31.5 [9.2]	28.7 [8.4]	
	Power	3.2	3.1	3.1	3.1	3.1	3.0	3.1	3.1	3.0	
105 [40.6]	Total BTUH [kW]	37.6 [11.0]	36.6 [10.7]	35.3 [10.3]	34.8 [10.2]	33.9 [9.9]	32.8 [9.6]	32.1 [9.4]	31.3 [9.2]	30.3 [8.9]	
	Sens BTUH [kW]	22.8 [6.7]	21.3 [6.2]	19.5 [5.7]	27.8 [8.1]	26.0 [7.6]	23.7 [6.9]	32.1 [9.4]	30.8 [9.0]	28.1 [8.2]	
	Power	3.3	3.3	3.2	3.3	3.2	3.2	3.2	3.2	3.2	
110 [43.3]	Total BTUH [kW]	36.2 [10.6]	35.3 [10.3]	34.1 [10.0]	33.4 [9.8]	32.6 [9.6]	31.5 [9.2]	30.8 [9.0]	30.0 [8.8]	29.0 [8.5]	
	Sens BTUH [kW]	22.0 [6.4]	20.6 [6.0]	18.8 [5.5]	27.0 [7.9]	25.3 [7.4]	23.1 [6.8]	30.8 [9.0]	30.0 [8.8]	27.4 [8.0]	
	Power	3.5	3.4	3.4	3.4	3.4	3.3	3.4	3.4	3.3	
115 [46.1]	Total BTUH [kW]	34.8 [10.2]	33.9 [9.9]	32.7 [9.6]	32.0 [9.4]	31.2 [9.1]	30.1 [8.8]	29.3 [8.6]	28.6 [8.4]	27.6 [8.1]	
	Sens BTUH [kW]	21.1 [6.2]	19.8 [5.8]	18.0 [5.3]	26.1 [7.6]	24.5 [7.2]	22.3 [6.5]	29.3 [8.6]	28.6 [8.4]	26.7 [7.8]	
	Power	3.6	3.6	3.5	3.6	3.6	3.5	3.6	3.5	3.5	
120 [48.9]	Total BTUH [kW]	33.2 [9.7]	32.4 [9.5]	31.3 [9.2]	30.5 [8.9]	29.7 [8.7]	28.7 [8.4]	27.8 [8.1]	27.1 [7.9]	26.2 [7.7]	
	Sens BTUH [kW]	20.2 [5.9]	18.9 [5.5]	17.2 [5.0]	25.2 [7.4]	23.6 [6.9]	21.5 [6.3]	27.8 [8.1]	27.1 [7.9]	25.9 [7.6]	
	Power	3.8	3.8	3.7	3.8	3.7	3.7	3.8	3.7	3.7	
125 [51.7]	Total BTUH [kW]	31.7 [9.3]	30.8 [9.0]	29.8 [8.7]	28.9 [8.5]	28.2 [8.3]	27.2 [8.0]	26.2 [7.7]	25.6 [7.5]	24.7 [7.2]	
	Sens BTUH [kW]	19.2 [5.6]	17.9 [5.2]	16.4 [4.8]	24.2 [7.1]	22.6 [6.6]	20.7 [6.1]	26.2 [7.7]	25.6 [7.5]	24.7 [7.2]	
	Power	4.0	4.0	3.9	4.0	3.9	3.9	4.0	3.9	3.8	

DR —Depression ratio
dbE —Entering air dry bulb
wbE—Entering air wet bulb

Total —Total capacity x 1000 BTUH
Sens —Sensible capacity x 1000 BTUH
Power—KW input

NOTES:

① When the entering air dry bulb is other than 80°F [27°C], adjust the sensible capacity from the table by adding [1.10 x CFM x (1 – DR) x (dbE – 80)].

[] Designates Metric Conversions

HEATING PERFORMANCE DATA—RHPXZS036

IDB		60°F [15.5°C]			70°F [21.1°C]			80°F [26.7°C]			
CFM [L/s]		1300 [614]	1200 [566]	950 [448]	1300 [614]	1200 [566]	950 [448]	1300 [614]	1200 [566]	950 [448]	
O U T D O O R D R Y B U L B T E M P E R A T U R E °F [°C]	0 [-17.8]	Total BTUH [kW] Power	13.1 [3.8] 2.1	13.0 [3.8] 2.1	12.8 [3.8] 2.2	12.3 [3.6] 2.3	12.2 [3.6] 2.3	12.0 [3.5] 2.4	11.4 [3.3] 2.6	11.4 [3.3] 2.6	11.2 [3.3] 2.7
	5 [-15.0]	Total BTUH [kW] Power	15.5 [4.5] 2.1	15.4 [4.5] 2.1	15.2 [4.5] 2.2	14.7 [4.3] 2.3	14.6 [4.3] 2.4	14.4 [4.2] 2.4	13.8 [4.0] 2.6	13.8 [4.0] 2.6	13.6 [4.0] 2.7
	10 [-12.2]	Total BTUH [kW] Power	18.0 [5.3] 2.2	17.9 [5.2] 2.2	17.6 [5.2] 2.2	17.1 [5.0] 2.4	17.0 [5.0] 2.4	16.8 [4.9] 2.5	16.3 [4.8] 2.6	16.2 [4.7] 2.7	15.9 [4.7] 2.7
	15 [-9.4]	Total BTUH [kW] Power	20.4 [6.0] 2.2	20.3 [5.9] 2.2	20.0 [5.9] 2.3	19.6 [5.7] 2.4	19.4 [5.7] 2.4	19.1 [5.6] 2.5	18.7 [5.5] 2.7	18.6 [5.5] 2.7	18.3 [5.4] 2.8
	20 [-6.7]	Total BTUH [kW] Power	22.8 [6.7] 2.2	22.7 [6.7] 2.3	22.4 [6.6] 2.3	22.0 [6.4] 2.5	21.9 [6.4] 2.5	21.5 [6.3] 2.5	21.1 [6.2] 2.7	21.0 [6.2] 2.8	20.7 [6.1] 2.8
	25 [-3.9]	Total BTUH [kW] Power	25.3 [7.4] 2.3	25.1 [7.4] 2.3	24.7 [7.2] 2.4	24.4 [7.2] 2.5	24.3 [7.1] 2.5	23.9 [7.0] 2.6	23.6 [6.9] 2.8	23.4 [6.9] 2.8	23.1 [6.8] 2.9
	30 [-1.1]	Total BTUH [kW] Power	27.7 [8.1] 2.3	27.5 [8.1] 2.4	27.1 [7.9] 2.4	26.8 [7.9] 2.5	26.7 [7.8] 2.6	26.3 [7.7] 2.6	26.0 [7.6] 2.8	25.9 [7.6] 2.8	25.5 [7.5] 2.9
	35 [1.7]	Total BTUH [kW] Power	30.1 [8.8] 2.4	29.9 [8.8] 2.4	29.5 [8.6] 2.5	29.3 [8.6] 2.6	29.1 [8.5] 2.6	28.7 [8.4] 2.7	28.4 [8.3] 2.8	28.3 [8.3] 2.9	27.8 [8.1] 2.9
	40 [4.4]	Total BTUH [kW] Power	32.6 [9.6] 2.4	32.4 [9.5] 2.4	31.9 [9.3] 2.5	31.7 [9.3] 2.6	31.5 [9.2] 2.6	31.1 [9.1] 2.7	30.9 [9.1] 2.9	30.7 [9.0] 2.9	30.2 [8.9] 3.0
	45 [7.2]	Total BTUH [kW] Power	35.0 [10.3] 2.4	34.8 [10.2] 2.5	34.3 [10.1] 2.5	34.1 [10.0] 2.7	33.9 [9.9] 2.7	33.4 [9.8] 2.8	33.3 [9.8] 2.9	33.1 [9.7] 3.0	32.6 [9.6] 3.0
50 [10.0]	Total BTUH [kW] Power	37.4 [11.0] 2.5	37.2 [10.9] 2.5	36.6 [10.7] 2.6	36.6 [10.7] 2.7	36.4 [10.7] 2.7	35.8 [10.5] 2.8	35.7 [10.5] 3.0	35.5 [10.4] 3.0	35.0 [10.3] 3.1	

IDB—Indoor air dry bulb

[] Designates Metric Conversions

COOLING PERFORMANCE DATA—RHPXZS048

		ENTERING INDOOR AIR @ 80°F [26.7°C] dbE ①									
		71°F [21.7°C]			67°F [19.4°C]			63°F [17.2°C]			
wbE		1825 [861]	1475 [696]	1325 [625]	1825 [861]	1475 [696]	1325 [625]	1825 [861]	1475 [696]	1325 [625]	
CFM [L/s]		1825 [861]	1475 [696]	1325 [625]	1825 [861]	1475 [696]	1325 [625]	1825 [861]	1475 [696]	1325 [625]	
DR ①		.05	.09	.12	.05	.09	.12	.05	.09	.12	
OUTDOOR DRY BULB TEMPERATURE	75 [23.9]	Total BTUH [kW]	60.0 [17.6]	57.5 [16.9]	56.5 [16.6]	57.2 [16.8]	54.8 [16.1]	53.8 [15.8]	54.3 [15.9]	52.1 [15.3]	51.1 [15.0]
		Sens BTUH [kW]	35.9 [10.5]	32.3 [9.5]	30.8 [9.0]	40.9 [12.0]	36.8 [10.8]	35.1 [10.3]	46.0 [13.5]	41.4 [12.1]	39.4 [11.5]
		Power	3.4	3.3	3.3	3.4	3.3	3.3	3.3	3.3	3.3
	80 [26.7]	Total BTUH [kW]	58.4 [17.1]	56.0 [16.4]	55.0 [16.1]	55.6 [16.3]	53.3 [15.6]	52.3 [15.3]	52.8 [15.5]	50.6 [14.8]	49.7 [14.6]
		Sens BTUH [kW]	35.3 [10.3]	31.8 [9.3]	30.2 [8.9]	40.3 [11.8]	36.3 [10.6]	34.6 [10.1]	45.3 [13.3]	40.8 [12.0]	38.9 [11.4]
		Power	3.6	3.5	3.5	3.5	3.5	3.4	3.5	3.5	3.5
	85 [29.4]	Total BTUH [kW]	56.9 [16.7]	54.5 [16.0]	53.5 [15.7]	54.0 [15.8]	51.8 [15.2]	50.8 [14.9]	51.2 [15.0]	49.1 [14.4]	48.2 [14.1]
		Sens BTUH [kW]	34.7 [10.2]	31.2 [9.1]	29.7 [8.7]	39.7 [11.6]	35.7 [10.5]	34.0 [10.0]	44.7 [13.1]	40.3 [11.8]	38.4 [11.3]
		Power	3.7	3.7	3.6	3.7	3.7	3.6	3.7	3.6	3.6
	90 [32.2]	Total BTUH [kW]	55.3 [16.2]	53.0 [15.5]	52.0 [15.2]	52.5 [15.4]	50.3 [14.7]	49.4 [14.5]	49.6 [14.5]	47.6 [14.0]	46.7 [13.7]
		Sens BTUH [kW]	34.0 [10.0]	30.6 [9.0]	29.2 [8.6]	39.1 [11.5]	35.2 [10.3]	33.5 [9.8]	44.1 [12.9]	39.7 [11.6]	37.8 [11.1]
		Power	3.9	3.9	3.8	3.9	3.8	3.8	3.9	3.8	3.8
95 [35.0]	Total BTUH [kW]	53.7 [15.7]	51.5 [15.1]	50.6 [14.8]	50.9 [14.9]	48.8 [14.3]	47.9 [14.0]	48.1 [14.1]	46.1 [13.5]	45.2 [13.2]	
	Sens BTUH [kW]	33.4 [9.8]	30.1 [8.8]	28.7 [8.4]	38.5 [11.3]	34.6 [10.1]	33.0 [9.7]	43.5 [12.7]	39.2 [11.5]	37.3 [10.9]	
	Power	4.1	4.0	4.0	4.1	4.0	4.0	4.1	4.0	4.0	
100 [37.8]	Total BTUH [kW]	52.2 [15.3]	50.0 [14.7]	49.1 [14.4]	49.3 [14.4]	47.3 [13.9]	46.4 [13.6]	46.5 [13.6]	44.6 [13.1]	43.8 [12.8]	
	Sens BTUH [kW]	32.8 [9.6]	29.5 [8.6]	28.1 [8.2]	37.8 [11.1]	34.1 [10.0]	32.5 [9.5]	42.9 [12.6]	38.6 [11.3]	36.8 [10.8]	
	Power	4.3	4.2	4.2	4.3	4.2	4.2	4.3	4.2	4.1	
105 [40.6]	Total BTUH [kW]	50.6 [14.8]	48.5 [14.2]	47.6 [14.0]	47.8 [14.0]	45.8 [13.4]	44.9 [13.2]	44.9 [13.2]	43.1 [12.6]	42.3 [12.4]	
	Sens BTUH [kW]	32.2 [9.4]	29.0 [8.5]	27.6 [8.1]	37.2 [10.9]	33.5 [9.8]	31.9 [9.3]	42.3 [12.4]	38.1 [11.2]	36.2 [10.6]	
	Power	4.5	4.4	4.4	4.5	4.4	4.3	4.5	4.4	4.3	
110 [43.3]	Total BTUH [kW]	49.0 [14.4]	47.0 [13.8]	46.1 [13.5]	46.2 [13.5]	44.3 [13.0]	43.5 [12.7]	43.4 [12.7]	41.6 [12.2]	40.8 [12.0]	
	Sens BTUH [kW]	31.6 [9.3]	28.4 [8.3]	27.1 [7.9]	36.6 [10.7]	33.0 [9.7]	31.4 [9.2]	41.7 [12.2]	37.5 [11.0]	35.7 [10.5]	
	Power	4.7	4.6	4.5	4.7	4.6	4.5	4.6	4.6	4.5	
115 [46.1]	Total BTUH [kW]	47.5 [13.9]	45.5 [13.3]	44.7 [13.1]	44.6 [13.1]	42.8 [12.5]	42.0 [12.3]	41.8 [12.3]	40.1 [11.8]	39.3 [11.5]	
	Sens BTUH [kW]	31.0 [9.1]	27.9 [8.2]	26.6 [7.8]	36.0 [10.6]	32.4 [9.5]	30.9 [9.1]	41.0 [12.0]	36.9 [10.8]	35.2 [10.3]	
	Power	4.9	4.8	4.7	4.9	4.8	4.7	4.8	4.7	4.7	
120 [48.9]	Total BTUH [kW]	45.9 [13.5]	44.0 [12.9]	43.2 [12.7]	43.1 [12.6]	41.3 [12.1]	40.5 [11.9]	40.2 [11.8]	38.6 [11.3]	37.8 [11.1]	
	Sens BTUH [kW]	30.4 [8.9]	27.3 [8.0]	26.0 [7.6]	35.4 [10.4]	31.9 [9.3]	30.3 [8.9]	40.2 [11.8]	36.4 [10.7]	34.7 [10.2]	
	Power	5.0	4.9	4.9	5.0	4.9	4.9	5.0	4.9	4.9	
125 [51.7]	Total BTUH [kW]	44.3 [13.0]	42.5 [12.5]	41.7 [12.2]	41.5 [12.2]	39.8 [11.7]	39.0 [11.4]	38.7 [11.3]	37.1 [10.9]	36.4 [10.7]	
	Sens BTUH [kW]	29.7 [8.7]	26.8 [7.9]	25.5 [7.5]	34.8 [10.2]	31.3 [9.2]	29.8 [8.7]	38.7 [11.3]	35.8 [10.5]	34.1 [10.0]	
	Power	5.2	5.1	5.1	5.2	5.1	5.1	5.2	5.1	5.1	

DR —Depression ratio
dbE —Entering air dry bulb
wbE—Entering air wet bulb

Total —Total capacity x 1000 BTUH
Sens —Sensible capacity x 1000 BTUH
Power—KW input

NOTES:

① When the entering air dry bulb is other than 80°F [27°C], adjust the sensible capacity from the table by adding [1.10 x CFM x (1 – DR) x (dbE – 80)].

[] Designates Metric Conversions

HEATING PERFORMANCE DATA—RHPXZS048

IDB		60°F [15.5°C]			70°F [21.1°C]			80°F [26.7°C]			
		CFM [L/s]	1650 [779]	1475 [696]	1200 [566]	1650 [779]	1475 [696]	1200 [566]	1650 [779]	1475 [696]	1200 [566]
O U T D O O R D R Y B U L B T E M P E R A T U R E	0 [-17.8]	Total BTUH [kW] Power	18.4 [5.4] 3.4	18.2 [5.3] 3.4	18.0 [5.3] 3.5	17.5 [5.1] 3.7	17.3 [5.1] 3.7	17.1 [5.0] 3.8	16.6 [4.9] 4.0	16.4 [4.8] 4.1	16.2 [4.7] 4.2
	5 [-15]	Total BTUH [kW] Power	21.2 [6.2] 3.2	21.1 [6.2] 3.2	20.8 [6.1] 3.3	20.3 [5.9] 3.5	20.2 [5.9] 3.6	19.9 [5.8] 3.6	19.4 [5.7] 3.8	19.3 [5.7] 3.9	19.0 [5.6] 4.0
	10 [-12.2]	Total BTUH [kW] Power	24.1 [7.1] 3.1	23.9 [7] 3.1	23.6 [6.9] 3.2	23.2 [6.8] 3.4	23.0 [6.7] 3.4	22.7 [6.7] 3.5	22.3 [6.5] 3.7	22.1 [6.5] 3.8	21.8 [6.4] 3.8
	15 [-9.4]	Total BTUH [kW] Power	26.9 [7.9] 3.0	26.7 [7.8] 3.0	26.4 [7.7] 3.1	26.0 [7.6] 3.3	25.8 [7.6] 3.3	25.5 [7.5] 3.4	25.1 [7.4] 3.6	24.9 [7.3] 3.7	24.6 [7.2] 3.7
	20 [-6.7]	Total BTUH [kW] Power	29.8 [8.7] 2.9	29.5 [8.6] 3.0	29.1 [8.5] 3.0	28.9 [8.5] 3.2	28.6 [8.4] 3.3	28.3 [8.3] 3.4	28.0 [8.2] 3.5	27.7 [8.1] 3.6	27.4 [8.0] 3.7
	25 [-3.9]	Total BTUH [kW] Power	32.6 [9.6] 2.9	32.4 [9.5] 2.9	31.9 [9.3] 3.0	31.7 [9.3] 3.2	31.5 [9.2] 3.3	31.0 [9.1] 3.3	30.8 [9.0] 3.5	30.5 [8.9] 3.6	30.1 [8.8] 3.7
	30 [-1.1]	Total BTUH [kW] Power	35.5 [10.4] 2.9	35.2 [10.3] 2.9	34.7 [10.2] 3.0	34.6 [10.1] 3.2	34.3 [10.1] 3.3	33.8 [9.9] 3.3	33.7 [9.9] 3.5	33.4 [9.8] 3.6	32.9 [9.6] 3.7
	35 [1.7]	Total BTUH [kW] Power	38.3 [11.2] 3.0	38 [11.1] 3.0	37.5 [11.0] 3.1	37.4 [11.0] 3.3	37.1 [10.9] 3.3	36.6 [10.7] 3.4	36.5 [10.7] 3.6	36.2 [10.6] 3.6	35.7 [10.5] 3.7
	40 [4.4]	Total BTUH [kW] Power	41.2 [12.1] 3.0	40.8 [12] 3.1	40.3 [11.8] 3.2	40.3 [11.8] 3.4	39.9 [11.7] 3.4	39.4 [11.5] 3.5	39.3 [11.5] 3.7	39.0 [11.4] 3.7	38.5 [11.3] 3.8
	45 [7.2]	Total BTUH [kW] Power	44.0 [12.9] 3.2	43.7 [12.8] 3.2	43.1 [12.6] 3.3	43.1 [12.6] 3.5	42.7 [12.5] 3.5	42.2 [12.4] 3.6	42.2 [12.4] 3.8	41.8 [12.3] 3.9	41.3 [12.1] 4.0
50 [10.0]	Total BTUH [kW] Power	46.9 [13.7] 3.3	46.5 [13.6] 3.4	45.9 [13.5] 3.5	46.0 [13.5] 3.6	45.6 [13.4] 3.7	45.0 [13.2] 3.8	45.0 [13.2] 4.0	44.7 [13.1] 4.0	44.1 [12.9] 4.1	

IDB—Indoor air dry bulb

[] Designates Metric Conversions

COOLING PERFORMANCE DATA – RHPXZS060

		ENTERING INDOOR AIR @ 80°F [26.7°C] dbE ①									
		wbE	71°F [21.7°C]			67°F [19.4°C]			63°F [17.2°C]		
		CFM [L/s]	2225 [1050]	1825 [861]	1600 [755]	2225 [1050]	1825 [861]	1600 [755]	2225 [1050]	1825 [861]	1600 [755]
		DR ①	.05	.09	.12	.05	.09	.12	.05	.09	.12
OUTDOOR DRY BULB TEMPERATURE	75 [23.9]	Total BTUH [kW]	73.8 [21.6]	70.9 [20.8]	69.4 [20.3]	69.4 [20.3]	66.7 [19.5]	65.2 [19.1]	65.3 [19.1]	62.8 [18.4]	61.4 [18.0]
		Sens BTUH [kW]	43.4 [12.7]	39.4 [11.5]	37.1 [10.9]	51.1 [15.0]	46.3 [13.6]	43.6 [12.8]	57.9 [17.0]	52.5 [15.4]	49.5 [14.5]
		Power	4.2	4.1	4.1	4.2	4.1	4.1	4.2	4.1	4.0
	80 [26.7]	Total BTUH [kW]	72.0 [21.1]	69.2 [20.3]	67.7 [19.8]	67.6 [19.8]	65.0 [19.1]	63.6 [18.6]	63.5 [18.6]	61.1 [17.9]	59.7 [17.5]
		Sens BTUH [kW]	42.6 [12.5]	38.7 [11.3]	36.4 [10.7]	50.3 [14.7]	45.6 [13.4]	43.0 [12.6]	57.1 [16.7]	51.8 [15.2]	48.8 [14.3]
		Power	4.4	4.3	4.3	4.4	4.3	4.3	4.4	4.3	4.2
	85 [29.4]	Total BTUH [kW]	70.1 [20.5]	67.4 [19.8]	65.9 [19.3]	65.7 [19.3]	63.2 [18.5]	61.8 [18.1]	61.6 [18.1]	59.2 [17.4]	57.9 [17.0]
		Sens BTUH [kW]	41.7 [12.2]	37.9 [11.1]	35.7 [10.5]	49.4 [14.5]	44.8 [13.1]	42.2 [12.4]	56.2 [16.5]	51.0 [14.9]	48.1 [14.1]
		Power	4.6	4.6	4.5	4.6	4.5	4.5	4.6	4.5	4.4
	90 [32.2]	Total BTUH [kW]	68.0 [19.9]	65.4 [19.2]	64.0 [18.8]	63.6 [18.6]	61.2 [17.9]	59.8 [17.5]	59.5 [17.4]	57.2 [16.8]	56.0 [16.4]
		Sens BTUH [kW]	40.8 [12.0]	37.0 [10.8]	34.9 [10.2]	48.4 [14.2]	43.9 [12.9]	41.4 [12.1]	55.3 [16.2]	50.1 [14.7]	47.2 [13.8]
		Power	4.9	4.8	4.7	4.9	4.8	4.7	4.8	4.7	4.7
95 [35.0]	Total BTUH [kW]	65.8 [19.3]	63.3 [18.6]	61.9 [18.1]	61.4 [18.0]	59.1 [17.3]	57.8 [16.9]	57.3 [16.8]	55.1 [16.1]	53.9 [15.8]	
	Sens BTUH [kW]	39.7 [11.6]	36.0 [10.6]	34.0 [10.0]	47.4 [13.9]	43.0 [12.6]	40.5 [11.9]	54.2 [15.9]	49.2 [14.4]	46.4 [13.6]	
	Power	5.1	5.0	5.0	5.1	5.0	5.0	5.1	5.0	4.9	
100 [37.8]	Total BTUH [kW]	63.5 [18.6]	61.1 [17.9]	59.7 [17.5]	59.1 [17.3]	56.8 [16.6]	55.6 [16.3]	55.0 [16.1]	52.9 [15.5]	51.7 [15.2]	
	Sens BTUH [kW]	38.6 [11.3]	35 [10.3]	33.0 [9.7]	46.2 [13.5]	41.9 [12.3]	39.5 [11.6]	53.1 [15.6]	48.2 [14.1]	45.4 [13.3]	
	Power	5.4	5.3	5.3	5.4	5.3	5.2	5.3	5.2	5.2	
105 [40.6]	Total BTUH [kW]	6.01 [17.9]	58.7 [17.2]	57.4 [16.8]	56.6 [16.6]	54.4 [15.9]	53.2 [15.6]	52.5 [15.4]	50.5 [14.8]	49.4 [14.5]	
	Sens BTUH [kW]	37.4 [11.0]	33.9 [9.9]	32.0 [9.4]	45.0 [13.2]	40.8 [12.0]	38.5 [11.3]	51.9 [15.2]	47.1 [13.8]	44.3 [13.0]	
	Power	5.7	5.6	5.5	5.7	5.6	5.5	5.6	5.5	5.5	
110 [43.3]	Total BTUH [kW]	58.4 [17.1]	56.2 [16.5]	54.9 [16.1]	54.0 [15.8]	51.9 [15.2]	50.8 [14.9]	49.9 [14.6]	48.0 [14.1]	46.9 [13.7]	
	Sens BTUH [kW]	36.1 [10.6]	32.7 [9.6]	30.8 [9.0]	43.7 [12.8]	39.7 [11.6]	37.4 [11.0]	49.9 [14.6]	45.9 [13.5]	43.2 [12.7]	
	Power	6.0	5.9	5.8	6.0	5.9	5.8	5.9	5.8	5.8	
115 [46.1]	Total BTUH [kW]	55.6 [16.3]	53.5 [15.7]	52.3 [15.3]	51.2 [15.0]	49.3 [14.4]	48.2 [14.1]	47.1 [13.8]	45.3 [13.3]	44.3 [13.0]	
	Sens BTUH [kW]	34.7 [10.2]	31.5 [9.2]	29.7 [8.7]	42.3 [12.4]	38.4 [11.3]	36.2 [10.6]	47.1 [13.8]	44.6 [13.1]	42.0 [12.3]	
	Power	6.3	6.2	6.2	6.3	6.2	6.1	6.3	6.2	6.1	
120 [48.9]	Total BTUH [kW]	52.7 [15.4]	50.7 [14.9]	49.6 [14.5]	48.3 [14.2]	46.5 [13.6]	45.4 [13.3]	44.2 [13.0]	42.5 [12.5]	41.6 [12.2]	
	Sens BTUH [kW]	33.2 [9.7]	30.1 [8.8]	28.4 [8.3]	40.9 [12.0]	37.1 [10.9]	34.9 [10.2]	44.2 [13.0]	42.5 [12.5]	40.8 [12.0]	
	Power	6.7	6.6	6.5	6.7	6.5	6.5	6.6	6.5	6.4	
125 [51.7]	Total BTUH [kW]	49.7 [14.6]	47.8 [14.0]	46.7 [13.7]	45.3 [13.3]	43.6 [12.8]	42.6 [12.5]	41.2 [12.1]	39.6 [11.6]	38.7 [11.3]	
	Sens BTUH [kW]	31.7 [9.3]	28.7 [8.4]	27.1 [7.9]	39.3 [11.5]	35.7 [10.5]	33.6 [9.8]	41.2 [12.1]	39.6 [11.6]	38.7 [11.3]	
	Power	7.1	6.9	6.8	7.0	6.9	6.8	7.0	6.9	6.8	

DR —Depression ratio
dbE —Entering air dry bulb
wbE—Entering air wet bulb

Total —Total capacity x 1000 BTUH
Sens —Sensible capacity x 1000 BTUH
Power —KW input

NOTES:

① When the entering air dry bulb is other than 80°F [27°C], adjust the sensible capacity from the table by adding [1.10 x CFM x (1 – DR) x (dbE – 80)].

[] Designates Metric Conversions

HEATING PERFORMANCE DATA—RHPXZS060

IDB		60°F [15.5°C]			70°F [21.1°C]			80°F [26.7°C]			
CFM [L/s]		2025 [956]	1825 [861]	1475 [696]	2025 [956]	1825 [861]	1475 [696]	2025 [956]	1825 [861]	1475 [696]	
O U T D O O R D R Y B U L B T E M P E R A T U R E	0 [-17.8]	Total BTUH [kW] Power	18.0 [5.3] 3.2	17.9 [5.2] 3.3	17.7 [5.2] 3.3	16.7 [4.9] 3.6	16.6 [4.9] 3.7	16.3 [4.8] 3.7	15.3 [4.5] 4.0	15.2 [4.5] 4.1	15.0 [4.4] 4.2
	5 [-15]	Total BTUH [kW] Power	22.1 [6.5] 3.2	21.9 [6.4] 3.3	21.6 [6.3] 3.4	20.7 [6.1] 3.6	20.6 [6.0] 3.7	20.3 [5.9] 3.8	19.4 [5.7] 4.0	19.2 [5.6] 4.1	19.0 [5.6] 4.2
	10 [-12.2]	Total BTUH [kW] Power	26.1 [7.6] 3.3	25.9 [7.6] 3.3	25.6 [7.5] 3.4	24.8 [7.3] 3.6	24.6 [7.2] 3.7	24.2 [7.1] 3.8	23.4 [6.9] 4.0	23.2 [6.8] 4.1	22.9 [6.7] 4.2
	15 [-9.4]	Total BTUH [kW] Power	30.1 [8.8] 3.3	29.9 [8.8] 3.3	29.5 [8.6] 3.4	28.8 [8.4] 3.7	28.6 [8.4] 3.7	28.2 [8.3] 3.8	27.4 [8.0] 4.1	27.2 [8.0] 4.1	26.9 [7.9] 4.2
	20 [-6.7]	Total BTUH [kW] Power	34.2 [10.0] 3.4	33.9 [9.9] 3.4	33.5 [9.8] 3.5	32.8 [9.6] 3.8	32.6 [9.6] 3.8	32.1 [9.4] 3.9	31.5 [9.2] 4.1	31.2 [9.1] 4.2	30.8 [9.0] 4.3
	25 [-3.9]	Total BTUH [kW] Power	38.2 [11.2] 3.4	37.9 [11.1] 3.5	37.4 [11.0] 3.6	36.9 [10.8] 3.8	36.6 [10.7] 3.9	36.1 [10.6] 4.0	35.5 [10.4] 4.2	35.2 [10.3] 4.3	34.8 [10.2] 4.4
	30 [-1.1]	Total BTUH [kW] Power	42.3 [12.4] 3.5	41.9 [12.3] 3.6	41.4 [12.1] 3.7	40.9 [12.0] 3.9	40.6 [11.9] 4.0	40.0 [11.7] 4.1	39.6 [11.6] 4.3	39.2 [11.5] 4.4	38.7 [11.3] 4.5
	35 [1.7]	Total BTUH [kW] Power	46.3 [13.6] 3.6	45.9 [13.5] 3.7	45.3 [13.3] 3.8	44.9 [13.2] 4.0	44.6 [13.1] 4.1	44.0 [12.9] 4.2	43.6 [12.8] 4.4	43.2 [12.7] 4.5	42.7 [12.5] 4.6
	40 [4.4]	Total BTUH [kW] Power	50.3 [14.7] 3.7	49.9 [14.6] 3.8	49.2 [14.4] 3.9	49.0 [14.4] 4.1	48.6 [14.2] 4.2	47.9 [14.0] 4.3	47.6 [14.0] 4.5	47.3 [13.9] 4.6	46.6 [13.7] 4.7
	45 [7.2]	Total BTUH [kW] Power	54.4 [15.9] 3.9	53.9 [15.8] 3.9	53.2 [15.6] 4.0	53.0 [15.5] 4.3	52.6 [15.4] 4.3	51.9 [15.2] 4.4	51.7 [15.2] 4.7	51.3 [15.0] 4.7	50.6 [14.8] 4.8
50 [10.0]	Total BTUH [kW] Power	58.4 [17.1] 4.0	57.9 [17.0] 4.1	57.1 [16.7] 4.2	57.0 [16.7] 4.4	56.6 [16.6] 4.5	55.8 [16.4] 4.6	55.7 [16.3] 4.8	55.3 [16.2] 4.9	54.5 [16.0] 5.0	

IDB—Indoor air dry bulb

[] Designates Metric Conversions

INDOOR AIRFLOW PERFORMANCE -- RHPXZS -- 208/230 VOLTS

Nominal Cooling Capacity Tons [kW]	Manufacturer Recommended Heat Pump Airflow (Min/Max)	Blower Size/ Motor HP [W] & # of Speeds	Motor Speed	External Static Pressure - Inches W.C. [kPa] (Side Discharge-Dry Coil)													
				0.1 [.02]	0.2 [.05]	0.3 [.07]	0.4 [.10]	0.5 [.12]	0.6 [.15]	0.7 [.17]	0.8 [.20]	0.9 [.23]	1.0 [.25]				
2.0 [7.03]	700 CFM/ 900 CFM	12 x 9T Blower 1/3 HP [249W] Ensite Air	Tap 1 Fan only	CFM [l/s]	1118 [528]	994 [469]	828 [391]	723 [341]	631 [298]	559 [264]	471 [222]	394 [186]	289 [136]	317 [150]			
				RPM	566	576	599	669	719	826	830	924	922				
			Tap 2 Heater Kit	Watts	150	131	109	120	128	143	146	159	155				
				CFM [l/s]	1135 [536]	1010 [477]	866 [409]	805 [380]	649 [306]	580 [274]	466 [220]	410 [193]	360 [170]				
			Tap 3 Y1	RPM	566	577	604	651	741	848	871	944					
				Watts	166	133	118	125	140	158	161	172					
			Tap 4 Y2	CFM [l/s]	800 [378]	725 [342]	500 [236]	382 [180]	324 [153]	289 [136]	197 [93]	182 [86]	0 [0]	0 [0]			
				RPM	416	472	594	668	618	702	773	0	0				
			Tap 5 Max static	Watts	53	59	72	80	82	84	91	0	0				
				CFM [l/s]	1196 [564]	1135 [536]	1113 [525]	1047 [494]	954 [450]	804 [379]	772 [364]	663 [313]	541 [255]				
			3.0 [10.55]	1050 CFM/ 1350 CFM	12 x 9T Blower 1/2 HP [373W] Ensite Air	Tap 1 Fan only	RPM	539	597	630	680	743	823	862	880	940	992
							Watts	152	165	172	183	196	213	222	227	240	252
Tap 2 Heater Kit	CFM [l/s]	1290 [609]				1275 [602]	1177 [555]	1156 [546]	1126 [531]	1095 [517]	844 [398]	794 [375]	785 [370]				
	RPM	586				634	682	740	774	817	928	950	967				
Tap 3 Y1	Watts	206				219	230	245	254	266	271	295	302	306			
	CFM [l/s]	974 [460]				920 [434]	856 [404]	794 [375]	626 [295]	559 [264]	349 [165]	314 [148]	253 [119]				
Tap 4 Y2	RPM	450				502	561	613	711	745	812	852	874	909			
	Watts	87				94	103	110	125	131	141	146	149	154			
Tap 5 Max Static	CFM [l/s]	1157 [546]				1126 [531]	1066 [503]	1014 [479]	958 [452]	850 [401]	733 [346]	692 [327]	622 [294]	535 [252]			
	RPM	515				546	599	647	696	779	836	863	931	963			
Tap 1 Fan only	Watts	133				140	150	160	170	187	200	204	217	225			
	CFM [l/s]	974 [460]				920 [434]	856 [404]	794 [375]	626 [295]	559 [264]	445 [210]	349 [165]	314 [148]	253 [119]			
Tap 2 Heater Kit	RPM	450	502	561	613	711	745	812	852	874	909						
	Watts	87	94	103	110	125	131	141	146	149	154						
Tap 3 Y1	CFM [l/s]	1447 [683]	1413 [667]	1384 [653]	1341 [633]	1294 [611]	1250 [590]	1209 [571]	1163 [549]	1113 [525]	973 [459]						
	RPM	614	643	668	709	750	790	828	869	908	1001						
Tap 4 Y2	Watts	246	255	263	274	287	300	309	323	336	366						
	CFM [l/s]	1581 [746]	1544 [729]	1497 [707]	1468 [693]	1425 [673]	1382 [652]	1305 [616]	1262 [596]	1227 [579]							
Tap 5 Max Static	RPM	649	677	707	740	776	815	853	887	925	959						
	Watts	307	317	327	340	352	366	380	390	405	418						

NOTES: Grey cells indicate airflow outside of manufacturers recommendation.
Do not connect wiring to unspecified speed taps.

[] Designates Metric Conversions

INDOOR AIRFLOW PERFORMANCE — RHPXZS — 208/230 VOLTS (Con't.)

Nominal Cooling Capacity Tons [kW]	Manufacturer Recommended Heat Pump Airflow (Min/Max)	Blower Size/ Motor HP [W] & # of Speeds	Motor Speed	External Static Pressure - Inches W.C. [kPa] (Side Discharge-Dry Coil)												
				0.1 [.02]	0.2 [.05]	0.3 [.07]	0.4 [.10]	0.5 [.12]	0.6 [.15]	0.7 [.17]	0.8 [.20]	0.9 [.23]	1.0 [.25]			
4.0 [14.07]	1400 CFM/ 1800 CFM	12 x 9T Blower 3/4 HP [559W] Ensife Air	Tap 1 Fan Only	CFM [l/s]	1400 [661]	1202 [567]	1057 [499]	1013 [478]	900 [425]	767 [362]	721 [340]	673 [318]	577 [272]	513 [242]		
				RPM	579	588	623	662	737	812	835	865	929	955		
			Tap 2 Heater Kit	Watts	194	163	154	162	177	193	205	218	224	224	224	
				CFM [l/s]	1400 [661]	1202 [567]	1057 [499]	1013 [478]	900 [425]	767 [362]	721 [340]	673 [318]	577 [272]	513 [242]	513 [242]	
			Tap 3 Y1	RPM	579	588	623	662	737	812	835	865	929	955	955	
				Watts	194	163	154	162	177	193	205	218	224	224	224	
	5.0 [17.58]	1750 CFM/ 2250 CFM	12 x 9T Blower 1 HP [746W] Ensife Air	Tap 4 Y2	CFM [l/s]	1712 [808]	1682 [794]	1636 [772]	1596 [753]	1545 [729]	1490 [703]	1444 [681]	1405 [663]	1371 [647]	1338 [631]	
					RPM	667	697	741	777	818	863	903	935	961	982	982
				Tap 5 Max static	Watts	327	339	356	371	386	405	433	444	451	451	451
					CFM [l/s]	1962 [926]	1929 [910]	1886 [890]	1850 [873]	1814 [856]	1783 [841]	1752 [827]	1702 [803]	1674 [790]	1629 [769]	1629 [769]
				Tap 1 Fan Only	RPM	755	775	806	839	867	902	933	980	1009	1048	1048
					Watts	487	498	512	529	544	561	579	604	619	644	644
5.0 [17.58]	1750 CFM/ 2250 CFM	12 x 9T Blower 1 HP [746W] Ensife Air	Tap 2 Heater Kit	CFM [l/s]	1396 [659]	1250 [590]	1199 [566]	1146 [541]	1095 [517]	1037 [489]	857 [404]	745 [352]	698 [329]	698 [329]		
				RPM	585	592	634	676	722	759	868	904	929	968	968	
			Tap 3 Y1	Watts	186	163	173	182	193	201	227	235	241	250	250	
				CFM [l/s]	1396 [659]	1250 [590]	1199 [566]	1146 [541]	1095 [517]	1037 [489]	857 [404]	745 [352]	698 [329]	698 [329]	698 [329]	
			Tap 4 Y2	RPM	585	592	634	676	722	759	868	904	929	968	968	
				Watts	186	163	173	182	193	201	227	235	241	250	250	
	5.0 [17.58]	1750 CFM/ 2250 CFM	12 x 9T Blower 1 HP [746W] Ensife Air	Tap 5 Max Static	CFM [l/s]	1468 [693]	1443 [681]	1389 [656]	1344 [634]	1291 [609]	1251 [590]	1086 [513]	975 [460]	915 [432]	915 [432]	
					RPM	609	638	683	722	767	796	831	913	977	1009	1009
				Tap 1 Fan Only	Watts	213	223	235	246	260	268	279	303	323	332	332
					CFM [l/s]	2095 [989]	2071 [977]	2043 [964]	2018 [952]	1981 [935]	1945 [918]	1913 [903]	1870 [883]	1839 [868]	1800 [850]	1800 [850]
				Tap 2 Heater Kit	RPM	808	829	856	877	911	935	970	1002	1029	1069	1069
					Watts	571	581	598	609	628	641	663	678	700	723	723
5.0 [17.58]	1750 CFM/ 2250 CFM	12 x 9T Blower 1 HP [746W] Ensife Air	Tap 3 Y1	CFM [l/s]	2262 [1068]	2245 [1060]	2218 [1047]	2190 [1034]	2158 [1018]	2135 [1008]	2100 [991]	2068 [976]	2002 [945]	1940 [916]		
				RPM	867	880	897	936	956	985	1017	1043	1076	1094	1094	
			Tap 4 Y2	Watts	736	748	760	784	797	818	841	858	865	865	846	
				CFM [l/s]	2095 [989]	2071 [977]	2043 [964]	2018 [952]	1981 [935]	1945 [918]	1913 [903]	1870 [883]	1839 [868]	1800 [850]	1800 [850]	
			Tap 5 Max Static	RPM	808	829	856	877	911	935	970	1002	1029	1069	1069	
				Watts	571	581	598	609	628	641	663	678	700	723	723	

NOTE: Grey cells indicate airflow outside of manufacturers recommendation.
Do not connect wiring to unspecified speed taps.

DOWN DISCHARGE PRESSURE DROP (ADD TO SIDE DISCHARGE EXTERNAL STATIC PRESSURE)			
CFM [L/s]	600 [283]	800 [378]	1000 [472]
Pressure Drop—Inches W.C. [kPa]	0	.02 [.005]	.05 [.012]
		.07 [.017]	.1 [.025]
		.12 [.030]	.15 [.037]
		.18 [.044]	.20 [.044]
		.25 [.062]	.30 [.075]
		.35 [.087]	.40 [.100]
		.45 [.112]	.50 [.125]
		.55 [.137]	.60 [.150]
		.65 [.162]	.70 [.175]
		.75 [.187]	.80 [.200]
		.85 [.212]	.90 [.225]
		.95 [.237]	1.0 [.250]

[] Designates Metric Conversions

ELECTRICAL DATA – RHPXZS SERIES								
		RHPXZS024AJT	RHPXZS036ACT	RHPXZS036AJT	RHPXZS048ACT	RHPXZS048AJT	RHPXZS060ACT	RHPXZS060AJT
Unit Information	Unit Operating Voltage Range	187-253	187-253	187-253	187-253	187-253	187-253	187-253
	Volts	208/230	208/230	208/230	208/230	208/230	208/230	208/230
	Phase	1	3	1	3	1	3	1
	Hz	60	60	60	60	60	60	60
	Minimum Circuit Ampacity	19	17	25	24	33	35	44
	Minimum Overcurrent Protection Device Size	25	20	30	30	40	40	50
	Maximum Overcurrent Protection Device Size	25	25	40	35	50	50	60
Compressor Motor	No.	1	1	1	1	1	1	1
	Volts	208-230	208-230	208-230	208-230	208-230	208-230	208-230
	Phase	1	3	1	3	1	3	1
	RPM							
	HP, Compressor 1							
	Amps (RLA), Comp. 1	10.9	8.8	15.3	12.6	19.9	17.2	23.7
	Amps (LRA), Comp. 1	55.2	70	78.1	123	109	110	151
	HP, Compressor 2							
	Amps (RLA), Comp. 2							
Amps (LRA), Comp. 2								
Condenser Motor	No.	1	1	1	1	1	1	1
	Volts	208-230	208-230	208-230	208-230	208-230	208-230	208-230
	Phase	1	1	1	1	1	1	1
	HP	1/6	1/3	1/3	1/3	1/3	1/2	1/2
	Amps (FLA, each)	0.6	1.5	1.5	1.5	1.5	5.3	5.3
	Amps (LRA, each)	1.5	3	3	3	3	—	—
Evaporator Fan	No.	1	1	1	1	1	1	1
	Volts	208-230	208/230	208/230	208/230	208/230	208/230	208/230
	Phase	1	1	1	1	1	1	1
	HP	1/3	1/2	1/2	3/4	3/4	1.0	1.0
	Amps (FLA, each)	2.8	4.1	4.1	6	6	7.6	7.6
	Amps (LRA, each)							

1. Horsepower Per Compressor.
2. Amp Draw Per Motor. Multiply Value By Number of Motors to Determine Total Amps.

Electric Heater Kit Factory Installed Options*	Unit Model Application
RXQJ-A10J (208-240 volt, 1-ph, 10kW)	RHPXZS024/036
RXQJ-A15J (208-240 volt, 1-ph, 15kW)	RHPXZS036
RXQJ-B15J (208-240 volt, 1-ph, 15kW)	RHPXZR048/060
RXQJ-A10C (208-240 volt, 3-ph, 10kW)	RHPXZS036
RXQJ-A15C (208-240 volt, 3-ph, 15kW)	RHPXZS036/048/060

*Further kits for field installation on following pages.

WARNING

ONLY ELECTRIC HEATER KITS SUPPLIED BY THIS MANUFACTURER AS DESCRIBED IN THIS PUBLICATION HAVE BEEN DESIGNED, TESTED, AND EVALUATED BY A NATIONALLY RECOGNIZED SAFETY TESTING AGENCY FOR USE WITH THIS UNIT. USE OF ANY OTHER MANUFACTURED ELECTRIC HEATERS INSTALLED WITHIN THIS UNIT MAY CAUSE HAZARDOUS CONDITIONS RESULTING IN PROPERTY DAMAGE, FIRE, BODILY INJURY OR DEATH.

208/240 VOLT, SINGLE PHASE, 60 Hz, AUXILIARY ELECTRIC HEATER KITS CHARACTERISTICS AND APPLICATION

Separate Power Supply for Both Unit and Heater Kit

Model Number	Heater Kit				Air Conditioner			Heater Kit			Air Conditioner		
	Heater Kit Nominal kW	Rated Heater kW @ 208/240 V	Heater Amp. @ 208/240 V	Unit Min. Ckt. Ampacity @ 208/240 V	Over Current Protective Device Size Min./Max.	Min. Ckt. Ampacity 208/240V	Max. Fuse Size 208/240	Min. Ckt. Ampacity 208/240 V	Over Current Protective Device Size Min./Max.	Min. Ckt. Ampacity 208/240 V	Max. Fuse Size 208/240	Min. Ckt. Ampacity 208/240 V	Over Current Protective Device Size Min./Max.
RHPXZS024AJT	NONE	—/—	—/—	19/19	25/25	—/—	—/—	19/19	25/25	—/—	—/—	19/19	25/25
	RXQJ-A05J	3.6/4.8	17.3/20	40/44	45/45	22/25	25/25	19/19	25/25	25/25	19/19	25/25	25/25
	RXQJ-A08J	5.7/7.6	27.4/31.6	53/58	60/60	35/40	35/40	19/19	25/25	35/40	19/19	25/25	25/25
	RXQJ-A10J	7.2/9.6	34.6/40	62/69	70/70	44/50	45/50	19/19	25/25	45/50	19/19	25/25	25/25
RHPXZS036AJT	NONE	—/—	—/—	25/25	40/40	—/—	—/—	25/25	40/40	—/—	—/—	25/25	40/40
	RXQJ-A05J	3.6/4.8	17.3/20	47/50	50/60	22/25	25/25	25/25	40/40	25/25	25/25	40/40	40/40
	RXQJ-A08J	5.7/7.6	27.4/31.6	59/65	60/70	35/40	35/40	25/25	40/40	35/40	25/25	40/40	40/40
	RXQJ-A10J	7.2/9.6	34.6/40	68/75	70/80	44/50	45/50	25/25	40/40	45/50	25/25	40/40	40/40
RHPXZS048AJT	NONE	—/—	—/—	90/100	90/100	65/75	70/80	25/25	40/40	70/80	25/25	40/40	40/40
	RXQJ-A05J	3.6/4.8	17.3/20	33/33	50/50	—/—	—/—	33/33	50/50	—/—	—/—	33/33	50/50
	RXQJ-A08J	5.7/7.6	27.4/31.6	54/58	60/70	22/25	25/25	33/33	50/50	25/25	33/33	50/50	50/50
	RXQJ-B10J	7.2/9.6	34.6/40	67/72	70/80	35/40	35/40	33/33	50/50	35/40	33/33	50/50	50/50
RHPXZS060AJT	NONE	—/—	—/—	98/108	100/110	65/75	70/80	33/33	50/50	70/80	33/33	50/50	50/50
	RXQJ-A05J	3.6/4.8	17.3/20	44/44	60/60	—/—	—/—	44/44	60/60	—/—	—/—	44/44	60/60
	RXQJ-A08J	5.7/7.6	27.4/31.6	66/69	80/80	22/25	25/25	44/44	60/60	25/25	44/44	60/60	60/60
	RXQJ-B10J	7.2/9.6	34.6/40	78/83	90/90	35/40	35/40	44/44	60/60	35/40	44/44	60/60	60/60
RHPXZS060AJT	RXQJ-B10J	7.2/9.6	34.6/40	87/94	100/100	44/50	45/50	44/44	60/60	45/50	44/44	60/60	60/60
	RXQJ-B15J	10.8/14.4	51.9/60	109/119	110/125	65/75	70/80	44/44	60/60	70/80	44/44	60/60	60/60

208/240 VOLT, 3-PHASE, 60 Hz, AUXILIARY ELECTRIC HEATER KITS CHARACTERISTICS AND APPLICATION

		Single Power Supply For Both Unit and Heater Kit				Separate Power Supply for Both Unit and Heater Kit			
Model Number	Heater Kit				Air Conditioner				
	Heater Kit Nominal kW	Rated Heater kW @ 208/240 V	Heater Amp. @ 208/240 V	Unit Min. Ckt. Ampacity @ 208/240 V	Over Current Protective Device Size Min./Max.	Min. Ckt. Ampacity 208/240V	Max. Fuse Size 208/240	Min. Ckt. Ampacity 208/240 V	Over Current Protective Device Size Min./Max.
RHPXZS036ACT	NONE	—/—	—/—	17/17	25/25	—/—	—/—	17/17	25/25
	RXQJ-A05C	3.8/5	10.4/12	30/32	35/35	15/15	15/15	17/17	25/25
	RXQJ-A08C	5.7/7.6	15.9/18.3	37/40	40/40	20/23	20/25	17/17	25/25
	RXQJ-A10C	7.2/9.6	20/23.1	42/46	45/50	25/29	25/30	17/17	25/25
RHPXZS048ACT	RXQJ-A15C	10.8/14.4	30.1/34.7	55/60	60/60	40/45	40/45	17/17	25/25
	NONE	—/—	—/—	24/24	35/35	—/—	—/—	24/24	35/35
	RXQJ-A05C	3.8/5	10.4/12	37/39	45/45	15/15	15/15	24/24	35/35
	RXQJ-A08C	5.7/7.6	15.9/18.3	44/47	50/50	20/23	20/25	24/24	35/35
RHPXZS060ACT	RXQJ-A10C	7.2/9.6	20/23.1	49/53	50/60	25/29	25/30	24/24	35/35
	RXQJ-A15C	10.8/14.4	30.1/34.7	61/67	70/70	38/44	40/45	24/24	35/35
	NONE	—/—	—/—	35/35	50/50	—/—	—/—	35/35	50/50
	RXQJ-A05C	3.8/5	10.4/12	48/50	60/60	15/15	15/15	35/35	50/50
RHPXZS060ACT	RXQJ-A08C	5.7/7.6	15.9/18.3	55/58	60/60	20/23	20/25	35/35	50/50
	RXQJ-A10C	7.2/9.6	20/23.1	60/64	70/70	25/29	25/30	35/35	50/50
	RXQJ-A15C	10.8/14.4	30.1/34.7	73/78	80/80	38/44	40/45	35/35	50/50

ACCESSORY EQUIPMENT

Accessory Description	Accessory Model No.
Roofcurb	RXSG-AXA14 (14" [356 mm] Height)
	RXSG-AXA24 (24" [610 mm] Height)
Curb Adapter ("A" footprint to "X" footprint)	RXRX-DXC AE
Duct Adapter Sideflow Square to Round Transition	AXMC-BA01
Supply & Return Diffusers	RXRN-BD15
Rectangular to Round Transition (Downflow)	RXMC-CA02 (16" [406 mm] Ducts)
	RXMC-CA03 (18" [457 mm] Ducts)
Economizers (Convertible)	RXRE-11RXCAM3
Dual Enthalpy Kit	PD555460
Fresh Air Damper	RXRF-FAA2 (Fixed-35%)
	RXRF-FAB2 (Motorized-35%)
Filter Kit	RXRY-B02
Split Door Design Kit	RXRX-SDX01
Low Ambient Control	RXPZ-G01
Phase Monitor Kit	RXRX-PM3A01

[] Designates Metric Conversions

COMMON SUPPLY/RETURN CONCENTRIC AIR DIFFUSER

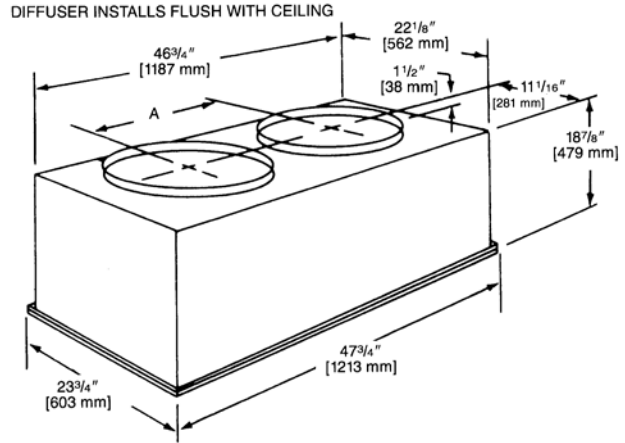
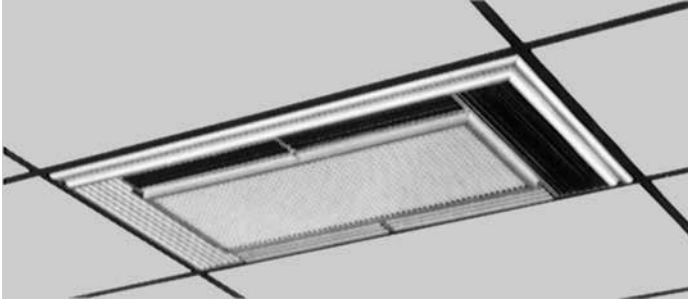

SUPPLY/RETURN DIFFUSER

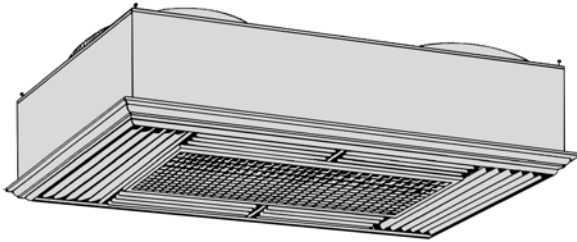

Designed to convert a side by side or an over and under arrangement into a concentric distribution of air. The diffuser is flush mounted, completely insulated, assembled, and internally baffled to provide four way supply air distribution with a center return. To make the assembly complete and ready to fit into a 2' [0.61 m] x 4' [1.22 m] suspended ceiling grid, the diffuser includes adjustable supply louvers, hanging rings, anti-sweat gasket, and round flanges for use with flexible ducts.

Model No. RXRN-	Diameter Inches [mm]	Shipping Wt. Lbs. [kg]	Dimension A Inches [mm]
BD15	16 [406]	90 [40.82]	20 1/2 [521]

[] Designates Metric Conversions

NOTE: The location of the combination supply and return diffuser should not exceed 10 feet [3.05 m] above the floor level for units @ 1000 CFM [472 L/s] or less and 12 [3.66 m] to 14 feet [4.27 m] above the floor level for units with CFM greater than 1000 [472 L/s]. If the diffuser is installed with a greater distance than recommended above, the supply air may become stratified above the required comfort area causing uncomfortable conditions.

AIRFLOW/PRESSURE DROP INFORMATION (INCHES W.C. [kPa])

Accessory	Approximate CFM [L/s]-Supply Air			
	1300 [614]	1575 [743]	1800 [850]	2200 [1038]
Plenum & Supply/Return Duct	.07 [.017]	.10 [.024]	.12 [.030]	.17 [.042]
Diffuser	.09 [.022]	.13 [.032]	.16 [.040]	.24 [.060]
Economizer	.06 [.015]	.09 [.022]	.11 [.027]	.17 [.042]

SUPPLY AIR/PERFORMANCE

Difuser Airflow CFM [L/s]	Range of Throw Ft.
800 [378]-1200 [566]	14 [4.27]-16 [4.88]
1600 [755]-2000 [944]	18 [5.49]-28 [8.53]

DUCT ADAPTERS RECTANGULAR TO ROUND TRANSITIONS (DOWNFLOW)

RXMC-CA02

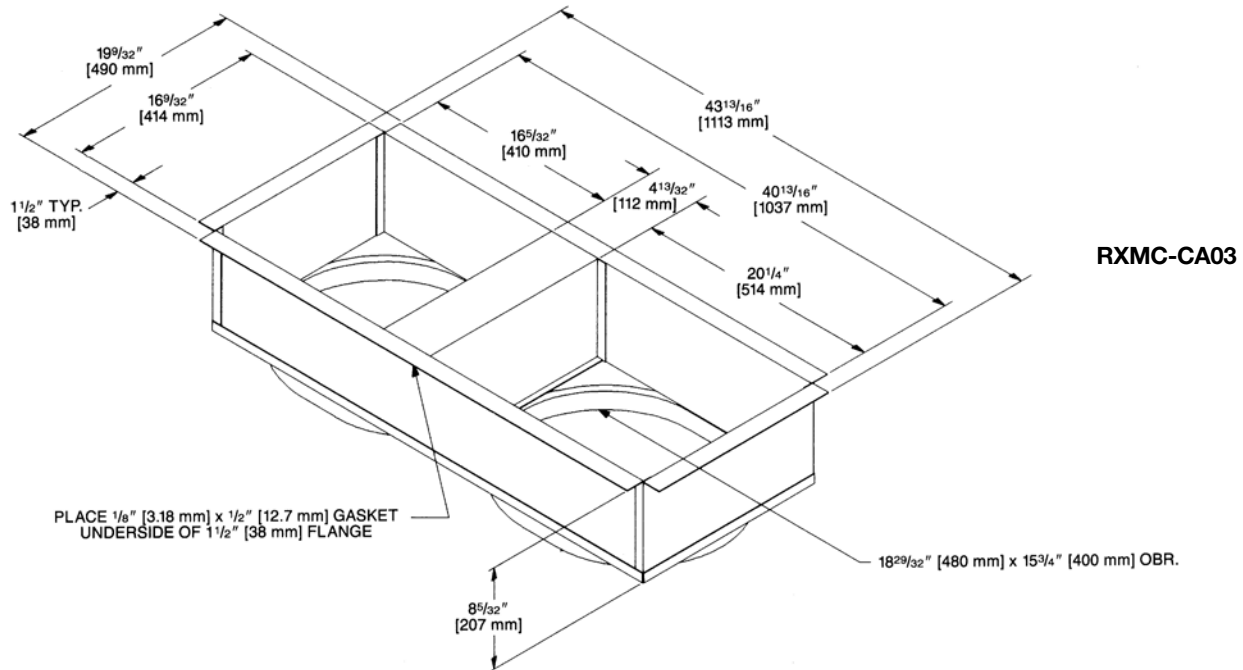
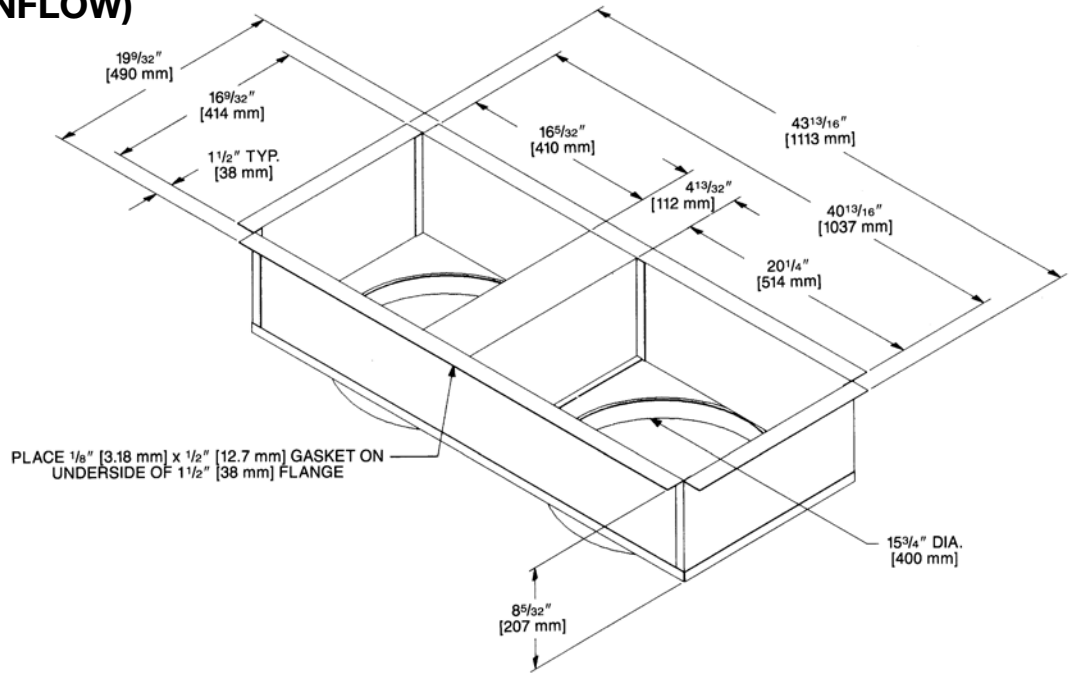

[] Designates Metric Conversions

DUCT ADAPTER SIDEFLOW SQUARE TO ROUND TRANSITION AXMC-BA01

Adapts the side rectangular supply and return openings to 14" [356 mm] diameter round openings. Adapters provided with same finish as unit and also provided with thermal insulation.

[] Designates Metric Conversions

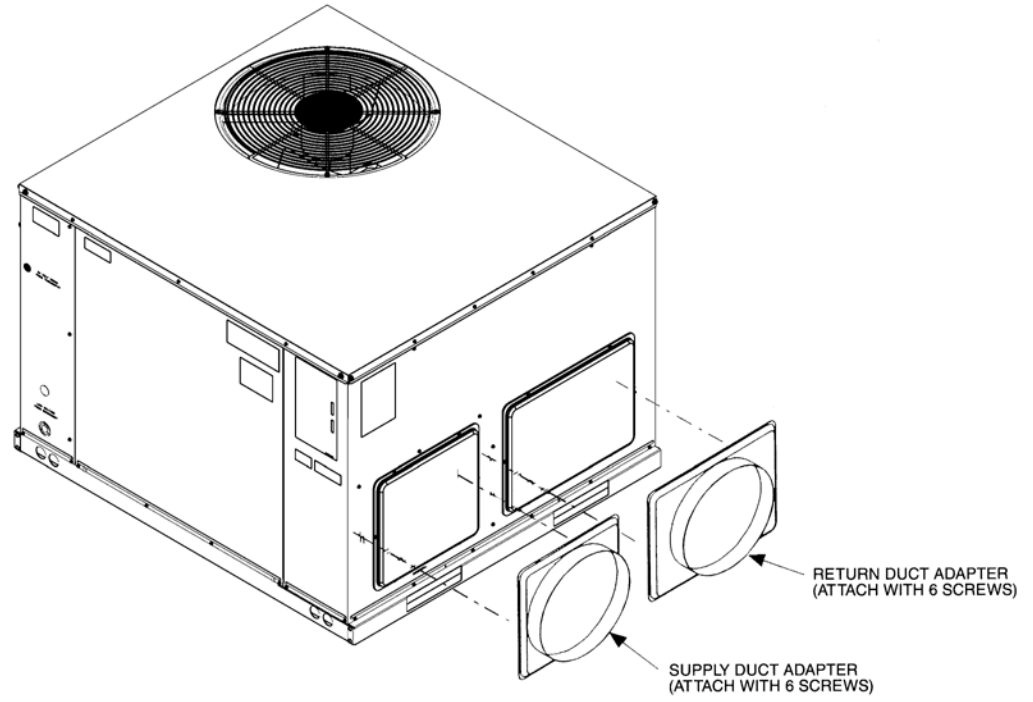

ROOFCURB (Full Perimeter) RXSG-AXA14 & RXSG-AXA24

Note: Hinged corners make
for fast, easy set-up.

RXSG-AXA14 (14" [356 mm] Height)

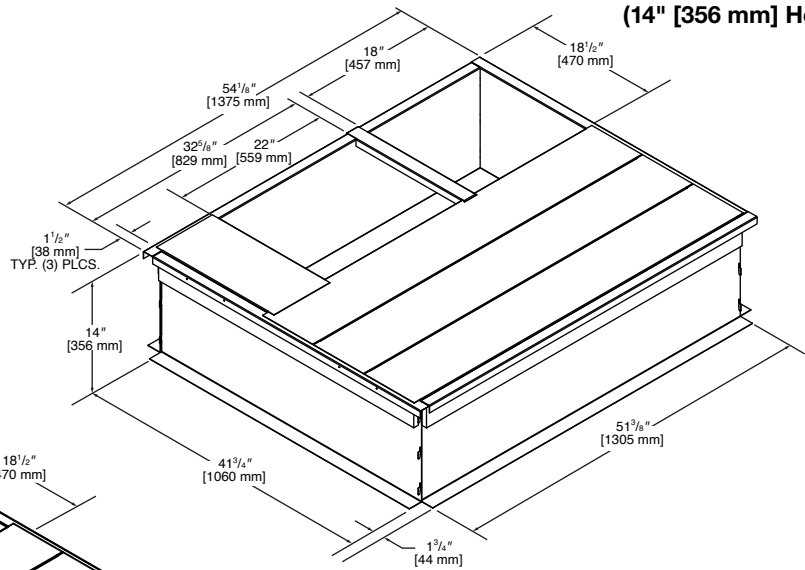

RXSG-AXA24 (24" [610 mm] Height)

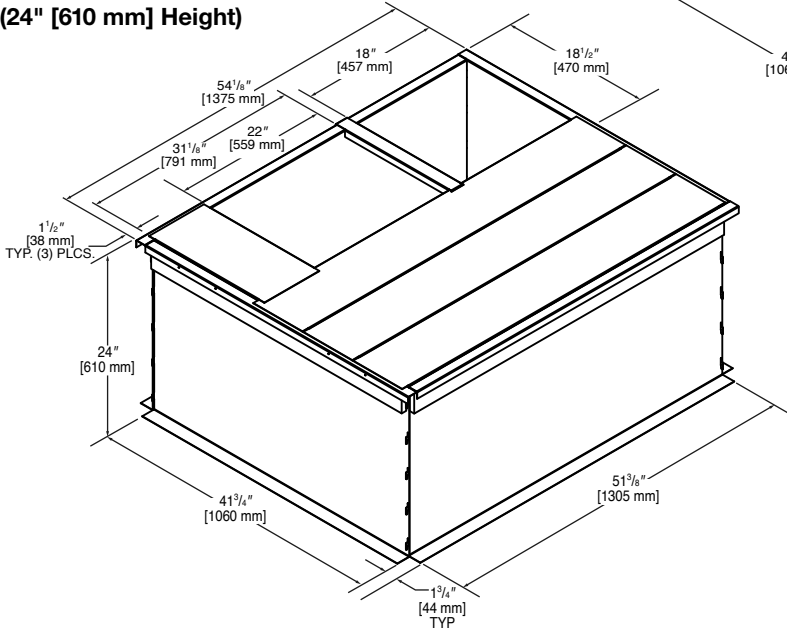

PACKAGED HEAT PUMP ROOFCURB INSTALLATION (Full Perimeter)

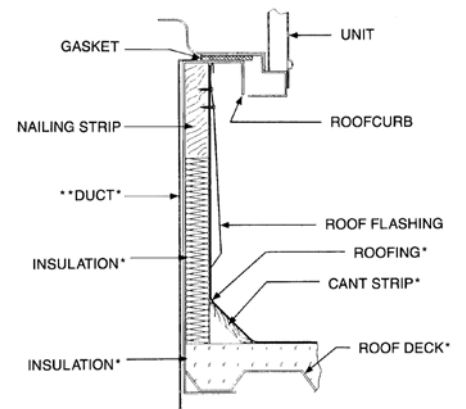
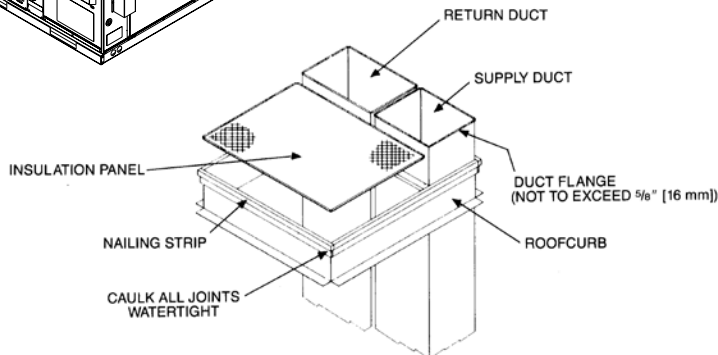
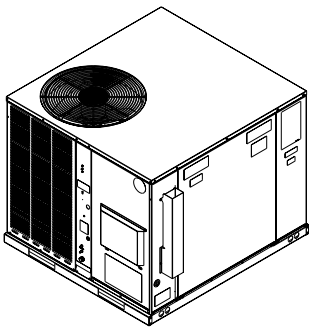

*BY CONTRACTOR
**FOR INSTALLATION OF DUCT AS SHOWN, USE RECOMMENDED DUCT SIZES FROM ROOFCURB INSTALLATION INSTRUCTIONS. FOR DUCT FLANGE AT TACHMENT TO UNIT, SEE UNIT INSTALLATION INSTRUCTIONS FOR RECOMMENDED DUCT SIZES.

[] Designates Metric Conversions

ROOFCURB ADAPTERS

Fabricated from galvanized steel to adapt the New cabinet to the old style curb. All are furnished with a New gasket.

OLD MODEL PACKAGE HEAT PUMP

SMALL CABINET
(1½-2 TON) [5.28-7.03 kW]
RPNC-
RPND-

MEDIUM CABINET
(2½-3 TON) [8.79-10.55 kW]
RPNC-
RPND-

EXTRA LARGE CABINET
(3½-5 TON) [12.31-17.58 kW]
RPNC-
RPND-

OLD CURB MODEL

20 SERIES

→ RXPA-CA20

21 SERIES

→ RXPA-CA21

23 SERIES

→ RXPA-CA23

“A” CABINET TO OLD MODEL ROOFCURB ADAPTER

RXPX-BACCA20
RXPX-BACCA21
RXPX-BCCCA23

“A” CABINET PACKAGE HEAT PUMP

RHPA-

“A” CABINET TO “X” CABINET ADAPTER

RXRX-DXCAE

“X” CABINET PACKAGE HEAT PUMP

RHPX-

[] Designates Metric Conversions

FRESH AIR DAMPER

RXRF-FAA2 (Fixed – 0-35%)

The 0-35% manual outside Air Damper is designed to replace the unit return air duct cover. No drilling or damper assembly is required. The amount of outside air (0-35%) is controlled by simply adjusting the side damper.

RXRF-FAB2 (Motorized – 0-35%)

The 0-35% manual outside Air Damper is designed to replace the unit return air duct cover. No drilling or damper assembly is required. The amount of outside air (0-35%) is controlled by simply adjusting the side damper.

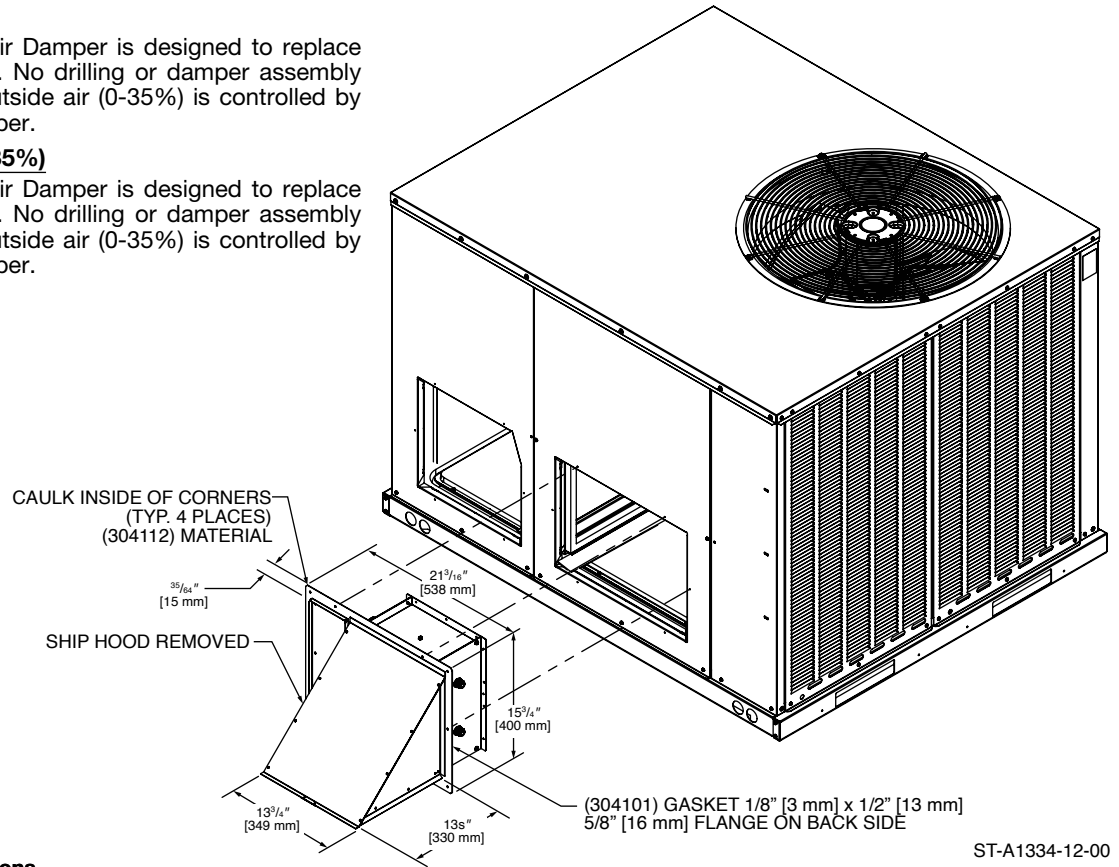

[] Designates Metric Conversions

ST-A1334-12-00

ECONOMIZER RXRE-11RXCAM3

- LCD Screen for Continuous diagnostic and system status
- Programmable set points for accurate positioning
- Simplified wiring and color coded terminals
- Onboard fault detection and diagnostics (FDD)
- Operational Checkout to verify installation
- Enthalpy sensors and actuator that communicate with Siemens controller reducing wiring errors while providing more information
- Setup and configure the economizer controller before putting it into usage by using the Climatix Mobile app or the inbuilt display
- CO2 sensor input for demand control ventilation (DCV) applications
- RXRX-BV03 dual enthalpy kit available for field installation
- AMCA licensed class 1A low leak dampers

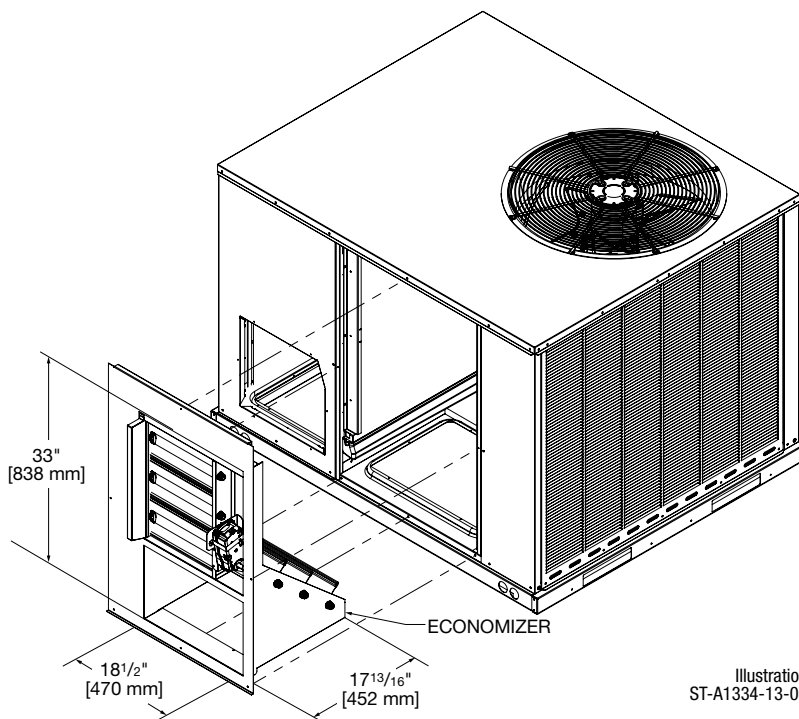

VERTICAL APPLICATION

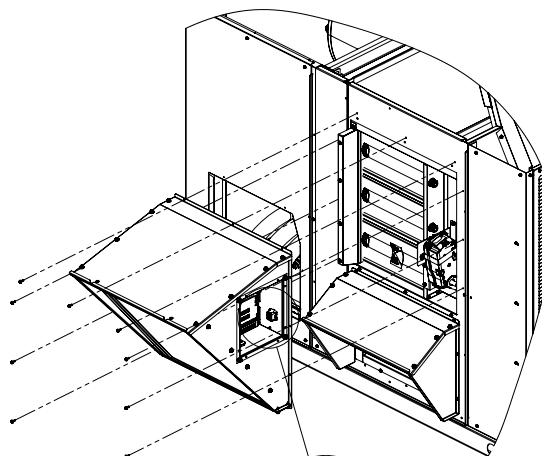
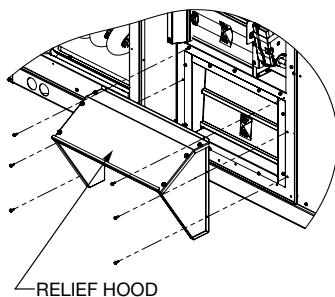
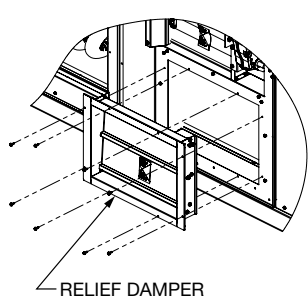

HORIZONTAL APPLICATION

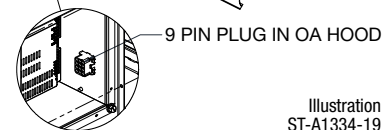
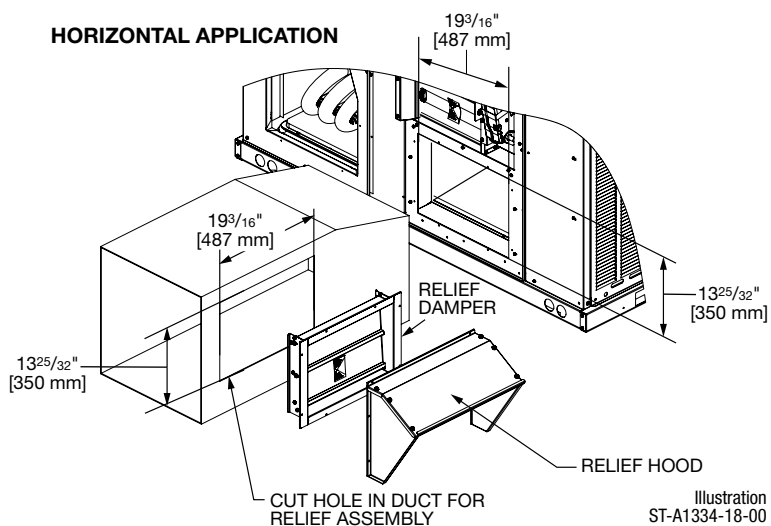

[] Designates Metric Conversions

FILTER KIT INSTALLATION

RXRY-B02

For use in either vertical or horizontal discharge.

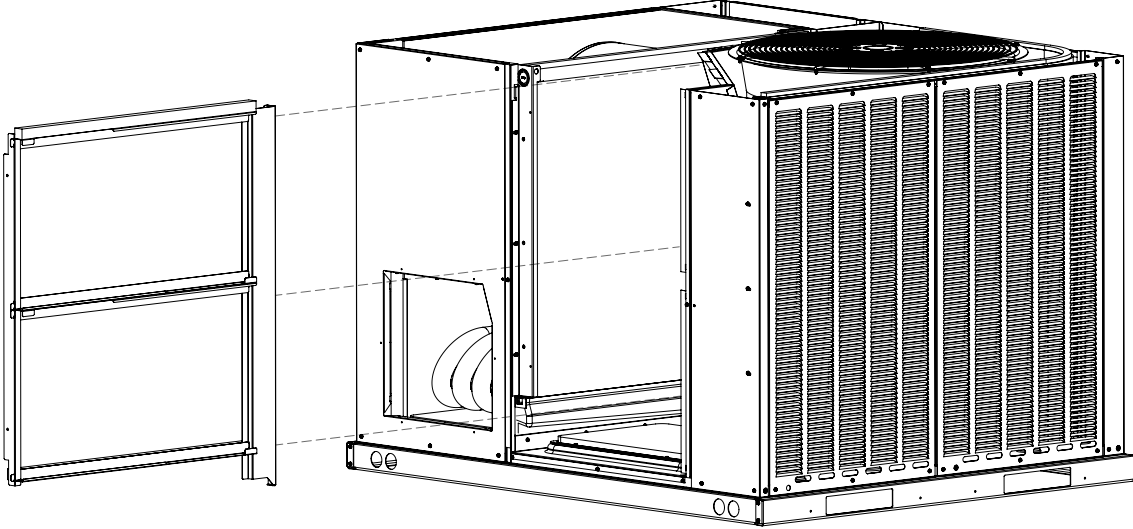

Illustration
ST-A1352-01-00

Airflow Pressure Drop (1" filter)	
CFM [L/s]	Inches W.C. [kPa]
600 [283]	0.01 [0.002]
800 [378]	0.01 [0.002]
1000 [472]	0.02 [0.005]
1200 [566]	0.03 [0.008]
1400 [661]	0.05 [0.012]
1600 [755]	0.07 [0.017]
1800 [850]	0.08 [0.021]
2000 [944]	0.10 [0.026]

[] Designates Metric Conversions



BEFORE PURCHASING THIS APPLIANCE, READ IMPORTANT ENERGY COST AND EFFICIENCY INFORMATION AVAILABLE FROM YOUR RETAILER.

GENERAL TERMS OF LIMITED WARRANTY*

Russell® By Rheem will furnish a replacement for any part of this product which fails in normal use and service within the applicable periods stated, in accordance with the terms of the limited warranty.

***For complete details of the Limited and Conditional Warranties, including applicable terms and conditions, contact your local contractor or the Manufacturer for a copy of the product warranty certificate.**

Conditional Parts (Registration Required)

1 Phase, Residential Applications Ten (10) Years

Compressor

1 Phase, Residential Applications Ten (10) Years

1 & 3 Phase, Commercial Applications Five (5) Years

Parts

1 & 3 Phase, Commercial Applications One (1) Year

Before proceeding with installation, refer to installation instructions packaged with each model, as well as complying with all Federal, State, Provincial, and Local codes, regulations, and practices.

© 2024 Rheem Manufacturing Company. Russell By Rheem trademarks owned by Rheem Manufacturing Company.

In keeping with its policy of continuous progress and product improvement, Russell by Rheem reserves the right to make changes without notice.

5600 Old Greenwood Road
Fort Smith, Arkansas 72908 • www.russellbyrheem.com