



**Russell**<sup>®</sup>  
By Rheem

PROJECT NAME \_\_\_\_\_  
LOCATION \_\_\_\_\_  
ARCHITECT \_\_\_\_\_  
ENGINEER \_\_\_\_\_  
CONTRACTOR \_\_\_\_\_  
SUBMITTED BY \_\_\_\_\_ DATE \_\_\_\_\_

**UNIT SUMMARY**

Quantity						
Unit Designation						
Model No.						
Total Cooling						
Sensible Cooling						
Air Ent. Evaporator						
Air Lvg. Evaporator						
Heating Input						
Heating Output						
CFM/ESP						
EER/SEER						
Electrical						
Minimum Ampacity						
Min.-Max. Breaker						
Net Unit Weight						
Accessory						
Catalog Form Number						

**ACCESSORIES:**

**NOTES:**

# Vantix™ Line RD17AZ Side-Discharge Universal Heat Pumps

## Cooling Efficiencies up to: 19 SEER2/12 EER2

## Heating Efficiencies up to: 8.5 HSPF2

### Nominal Sizes: 2 to 5 Ton [7.0 to 17.6 kW]

JOB NAME \_\_\_\_\_ LOCATION \_\_\_\_\_

CONTRACTOR \_\_\_\_\_ ORDER NO. \_\_\_\_\_

ENGINEER \_\_\_\_\_ UNIT MODEL NO. \_\_\_\_\_

SUBMITTED FOR  APPROVAL  RECORD COIL MODEL NO. \_\_\_\_\_

DATE \_\_\_\_\_ AIR HANDLER MODEL NO. \_\_\_\_\_

### UNIT DATA

#### COOLING PERFORMANCE

EFFICIENCY ..... SEER

TOTAL CAPACITY\* ..... MBH [kW]

SENSIBLE CAPACITY\* ..... MBH [kW]

OUTDOOR DESIGN TEMP..... °F [°C] DB

TEMP. OF AIR ENTERING  
EVAPORATOR COIL ..... °F [°C] DB

..... °F [°C] WB

POWER INPUT REQUIREMENT ..... kW  
(\*uses blower motor heat)

#### HEATING PERFORMANCE

EFFICIENCY ..... HSPF

TOTAL CAPACITY\* ..... MBH [kW]

OUTDOOR DESIGN TEMP..... °F [°C] DB

TEMP. OF AIR ENTERING  
EVAPORATOR COIL ..... °F [°C] DB

#### SUPPLY AIR BLOWER PERFORMANCE

TOTAL AIR SUPPLY..... CFM [L/s]

TOTAL RESISTANCE EXTERNAL  
TO UNIT ..... IWG

BLOWER SPEED..... RPM

POWER OUTPUT REQUIREMENT ..... BHP

MOTOR RATING ..... HP [W]

POWER INPUT REQUIREMENT ..... kW

#### ELECTRICAL DATA

POWER SUPPLY ..... Hz

TOTAL UNIT AMPACITY..... AMPS

MINIMUM WIRE SIZE ..... AWG

MAXIMUM OVERCURRENT DEVICE  
FUSES/HACR BREAKER ..... AMPS

#### CLEARANCES

ACCESS SIDE 24" [609.6 mm]

AIR INLETS 12" [304.8 mm]

ABOVE UNIT 60" [1524 mm]



### FEATURES

- Flexible & Universal Install Compatibility:**
  - Works with nearly any HVAC System – including EcoNet® Enabled systems and non-communicating systems
  - Install with any indoor system component via an algorithm  
**(IMPORTANT:** the indoor system component CFM must match the requirement of the outdoor system component)
  - Install as a Universal Replacement with minimal alterations (coil only – with TXV)
- Space Saver Solution:** The RD17AZ – with footprint options as low as 36.6" tall and 40.2" wide – is ideal for when installation locations are constrained; but is also perfect for any system or replacement option where an efficient, streamlined look is desired
- Quiet Operation as low as 58dB<sup>1</sup>:** Offers sound dampening features such as a sound blanket, refrigerant tubing design, fan blade approach and innovative compressor and drive technologies – ensure that as efficiency goes up, sound levels stay low
- EcoNet® Enabled<sup>2</sup>:** Automatic system configuration and optimization
- Diagnostics & Bluetooth<sup>3, 4</sup> Connectivity:** With the Contractor & EcoNet® Apps, built-in technology makes advanced set-up, monitoring, troubleshooting, and repairing the product easier than ever before
- Variable Speed Twin Rotary Compressor & Inverter Drive:**
  - Features variable speed operation from 45 to 100% capacity with the EcoNet® Smart Thermostat or with legacy and other thermostats when the utility 1 & 2 jumpers are installed or using the algorithm<sup>5</sup>
  - Provides precise temperature control, advanced humidity control and greater efficiency
- Brushless DC Condenser Motors (BLDC):** Enhances reliability and allows for easier serviceability
- Swept Wing Fan Technology:** Features quieter operation and improved unit acoustics
- 7mm Condenser Copper Coil:** Requires less refrigerant allowing for a smaller and lighter footprint while enhancing reliability
- Optional Base Pan Heater:** Utilizes a built-in thermostat to regulate the heating operation to prevent ice build-up on the base pan during extreme cold weather conditions



9001:2015



Intertek



*\*Proper sizing and installation of equipment is critical to achieve optimal performance. Split system air conditioners and heat pumps must be matched with appropriate coil components to meet Energy Star. Ask your Contractor for details or visit [www.energystar.gov](http://www.energystar.gov).*

## FEATURES (Con't.)

- **Traditional Refrigerant Piping:** Allows for use of existing refrigerant line sets for further ease of replacement installation flexibility
- **10-Year Conditional Parts Warranty (registration required):** Coverage when installed as a heat pump only or as part of a system – with no AHRI matched system requirement
- **Qualifies for Federal Incentives (conditions apply):**
  - Federal Tax Credit compliant system combinations across all product tonnages (effective through 12/31/32) – up to \$2000 for qualified heat pumps

<sup>1</sup>Based on Internal R&D Testing, 2023 Sound levels are also dependent on proper installation and location of outdoor product.

<sup>2</sup>When installed as part of a complete AHRI-matched, EcoNet® Enabled system.

<sup>3</sup>The Bluetooth® word mark and logos are registered trademarks owned by Bluetooth SIG, Inc. and any use of such marks by Rheem® is under license. Other trademarks and trade names are those of their respective owners.

## ACCESSORIES/OPTIONS

- Compressor Crankcase Heater.....
- Compressor Hard Start Kit.....
- Liquid Line Solenoid (24 VAC, 50/60 Hz).....
- Liquid Line Solenoid (120/40 VAC, 50/60 Hz).....
- Basepan Heater.....

<sup>4</sup>When installed as part of a complete system where both the outdoor & indoor components feature Bluetooth® Technology.

<sup>5</sup>Two-Stage (70% & 100% capacity) operation when installed with legacy and other thermostats when the utility 1 & 2 jumpers are not installed. The 2-Ton model features a single rotary compressor.

## RD17AZ

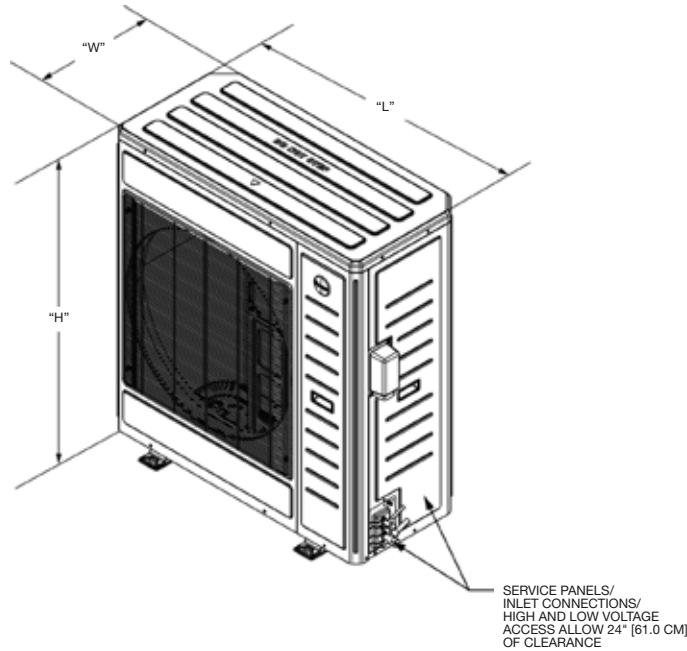

Illustration  
A1345-02-00

## Unit Dimensions

MODEL NO.	OPERATING						SHIPPING					
	H (Height)		L (Length)		W (Width)		H (Height)		L (Length)		W (Width)	
	INCHES	mm	INCHES	mm	INCHES	mm	INCHES	mm	INCHES	mm	INCHES	mm
RD17AZ24AJ3NA	36.61	930	40.16	1020	16.38	416	43.31	1100	48.43	1230	22.05	560
RD17AZ36AJ3NA	46.38	1178	42.01	1067	19.29	490	53.94	1370	50.00	1270	25.00	635
RD17AZ48AJ3NA	57.80	1468	40.16	1020	16.38	416	65.16	1655	48.43	1230	22.05	560
RD17AZ60AJ3NA	57.80	1468	40.16	1020	16.38	416	65.16	1655	48.43	1230	22.05	560

[ ] Designates Metric Conversions

**Before proceeding with installation, refer to installation instructions packaged with each model, as well as complying with all Federal, State, Provincial, and Local codes, regulations, and practices.**

5600 Old Greenwood Road  
Fort Smith, Arkansas 72908

© 2024 Rheem Manufacturing Company. Russell By Rheem and Sure Comfort trademarks owned by Rheem Manufacturing Company.

"In keeping with its policy of continuous progress and product improvement, Rheem reserves the right to make changes without notice."