



Vantix™ Line iR Residential Packaged Heat Pumps



RHPXYC

Nominal Sizes: 3 to 5 Tons [10.6 to 17.6 kW]

Cooling Efficiency: 15.2 SEER2

Heating Efficiency: 7.2 HSPF2

Refrigerant Type: R-454B



¹Proper sizing and installation of equipment is critical to achieve optimal performance. Split system air conditioners and heat pumps must be matched with appropriate coil components to meet ENERGY STAR®. Ask your Contractor for details or visit www.energystar.gov.

Table of Contents

Features and Benefits.....	3
Model Number Identification	4
Dimensional Data	5-6
Typical Installations	7
General Data.....	8-10
General Data Notes	11
Gross Systems Performance Data	12-17
Indoor Airflow Performance.....	18-19
Electrical Data.....	20-21
Electric Heater Kits.....	22-25
Accessories	26-34
Limited Warranty.....	36

Features and Benefits

- **Two-Stage Scroll Compressors on all models:** Provides maximum efficiency and quiet operation
- **MicroChannel Evaporator and Condenser Coil:** Delivers superior performance with a robust surface, a decreased refrigerant requirement and is lighter than conventional copper tube/aluminum fin coils. All-aluminum construction offers superior protection against formicary corrosion and aluminum tube rubbing damage. The design allows for easier and faster cleaning
- **Two Thermal Expansion Valves:** Standard on all models for precise superheat control, reliability, and energy efficiency at all operating conditions
- **High and Low Pressure Control:** Standard on all models for refrigerant component protection and reliability
- **Filter Drier:** Standard on all models
- **100% Factory Run Tested**
- **Refrigerant Detection System:** An integrated one-box, patented design featuring the A2L sensor and mitigation board, offering easier commissioning with a single component and simplified wiring configuration, compatibility with any 24V thermostat application and system protection by automatically pausing outdoor unit operation — if excess refrigerant is detected
- **Rugged Base Rail:** Contributes to improved installation and handling
- **Easily Accessible Control Box and Slide-Out Blower Section:** Allows for faster installability and serviceability
- **Side and Down Discharge Options Available:** All models are shipped ready for horizontal applications
- **Double Sloped Evaporator Coil Drain Pan:** Allows for complete water removal from the unit — contributing to improved indoor air quality
- **Louvered Condenser Compartment:** Protects the coil against yard hazards and/or weather extremes
- **Supply and Return Air Openings:** Feature a one-inch-tall flange to prevent water migration into the ductwork
- **Supplemental Electric Heating Option Available:** Factory or field-installed, electrical heat strips, up to 15 kW with simplified single-point wiring, are available for periods of extreme weather conditions
- **Designing for sustainability with low GWP:** For 2025, the Environmental Protection Agency (EPA) has set a global warming potential (GWP) limit of 700 for refrigerant used in heating and cooling systems. This new requirement will result in a 78%¹ lower GWP than previous-generation refrigerants with only minimal changes to system installation. For us, this is another step toward our continued sustainability goal of reducing greenhouse gas emissions, while still delivering an exceptional level of energy efficient, dependable comfort

¹When comparing the GWP of R-454B to R-410A refrigerant.

Packaged Heat Pumps

<u>R</u>	<u>HP</u>	<u>X</u>	<u>Y</u>	<u>C</u>	<u>036</u>	<u>A</u>	<u>J</u>	<u>T</u>	<u>00</u>	<u>0</u>	<u>N</u>	<u>A</u>
Brand	Product Category	Platform	Refrigerant	Tier	Capacity BTU/HR	Major Series	Voltage	Drive	Electric Heat	Electric Heat Configuration	Control	Minor Series
R - Russell® By Rheem	HP - Heat Pump	X - ResiPack Convertible	Y - R-454B	C - Mid Tier (15.2 SEER2)	036 - 36,000 [10.55 kW] 048 - 48,000 [14.07 kW] 060 - 60,000 [17.58 kW]	A - 1st Design	J - 1ph, 208/230/60 C - 3ph, 208/230/60 D - 3ph, 460/60	T - Constant Torque	00 - No Electric Heat 10 - 10 kW Electric Heat 15 - 15 kW Electric Heat	0 - No Electric Heat 1 - Electric Heat Factory Installed	N - Non-Communicating	A - 1st Design

[] Designates Metric Conversions

Available Models
RHPXYC036ACT000NA
RHPXYC036ACT101NA
RHPXYC036ACT151NA
RHPXYC036ADT000NA
RHPXYC036ADT101NA
RHPXYC036ADT151NA
RHPXYC036AJT000NA
RHPXYC036AJT101NA
RHPXYC036AJT151NA
RHPXYC048ACT000NA
RHPXYC048ACT151NA
RHPXYC048ADT000NA
RHPXYC048ADT151NA
RHPXYC048AJT000NA
RHPXYC048AJT151NA
RHPXYC060ACT000NA
RHPXYC060ACT151NA
RHPXYC060ADT000NA
RHPXYC060ADT151NA
RHPXYC060AJT000NA
RHPXYC060AJT151NA

NOTE: Further heater kits available to purchase for field installation.

DIMENSIONAL DATA

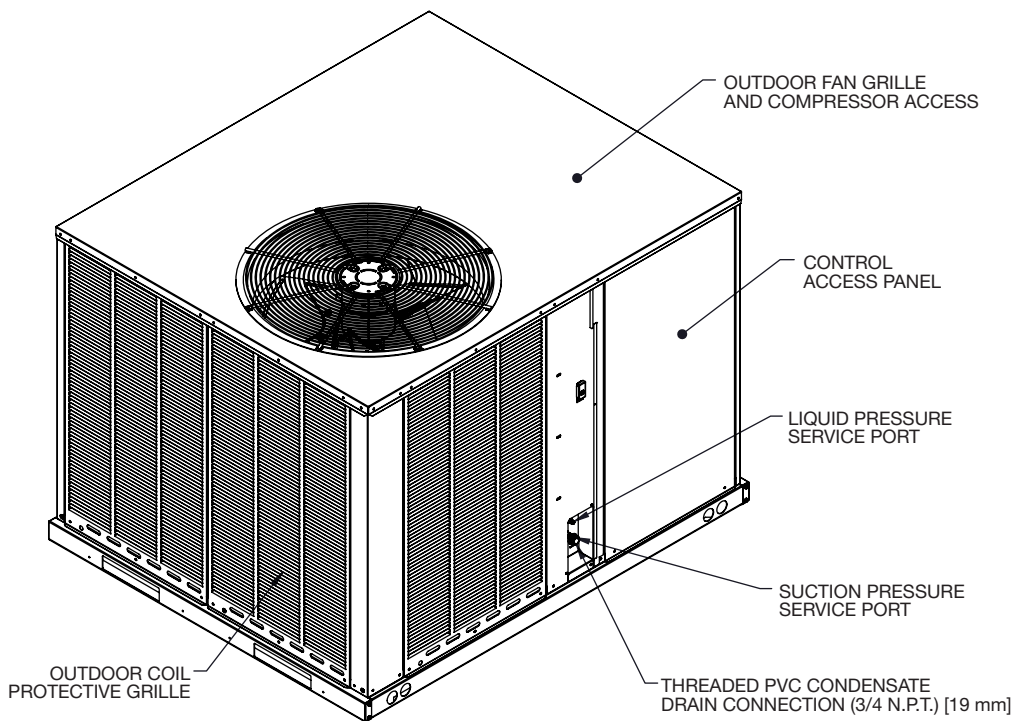
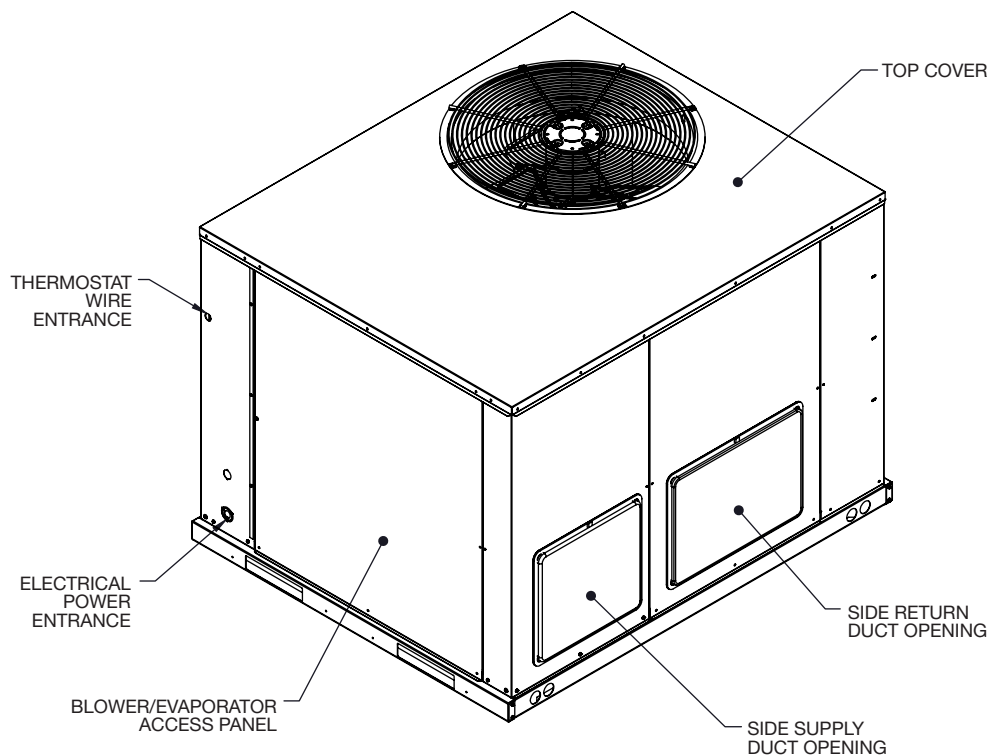

Illustration
ST-A1334-01

[] Designates Metric Conversions

DIMENSIONAL DATA

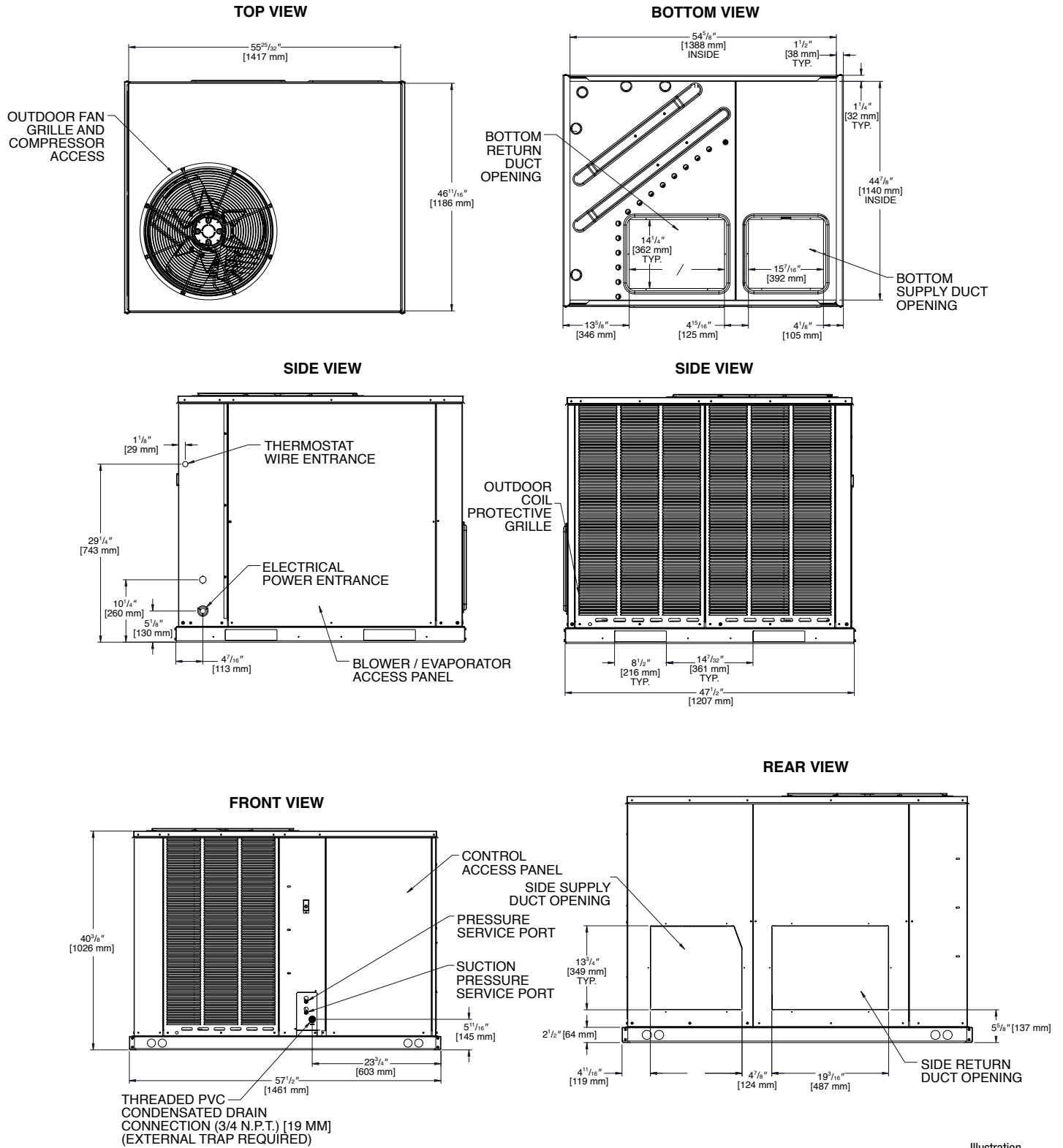
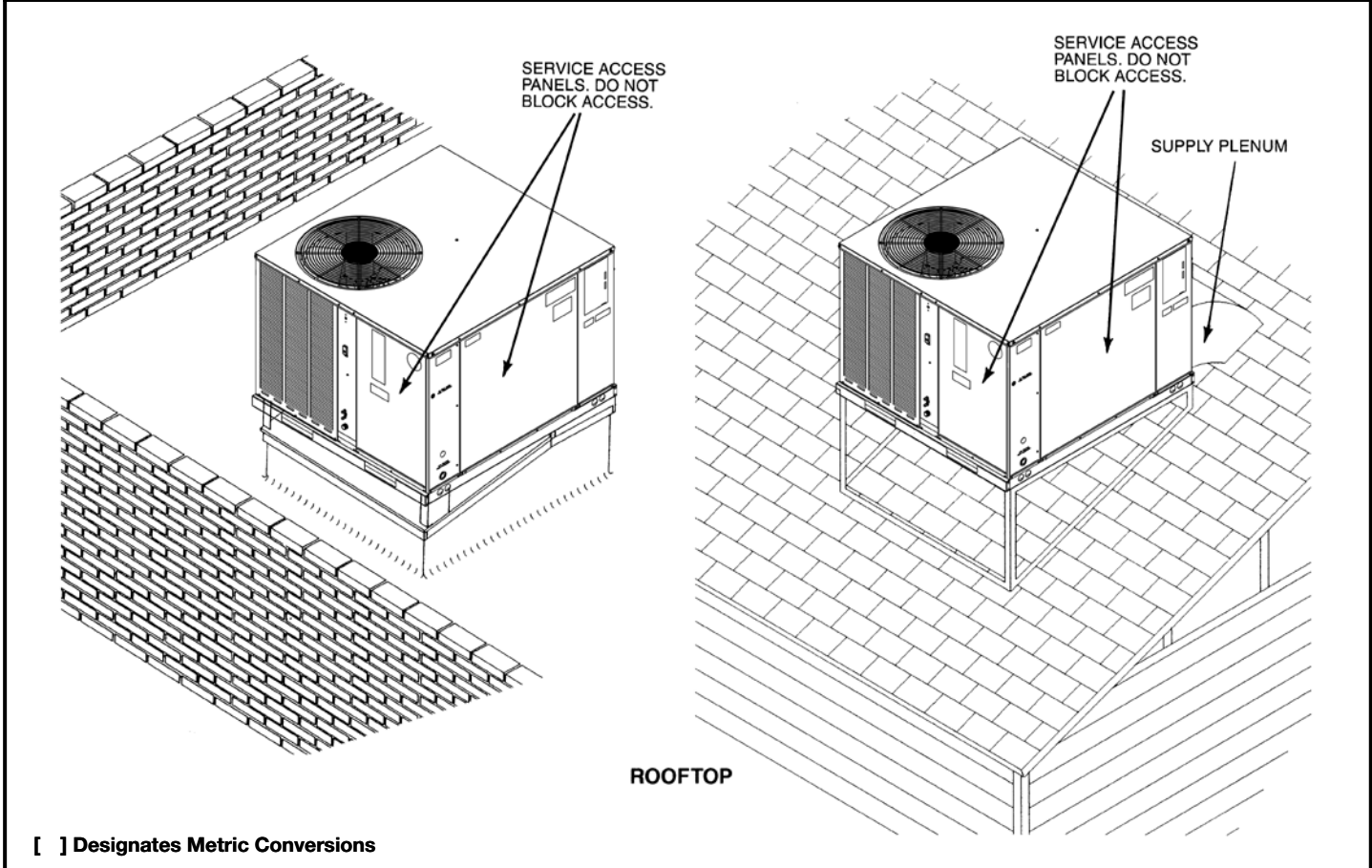
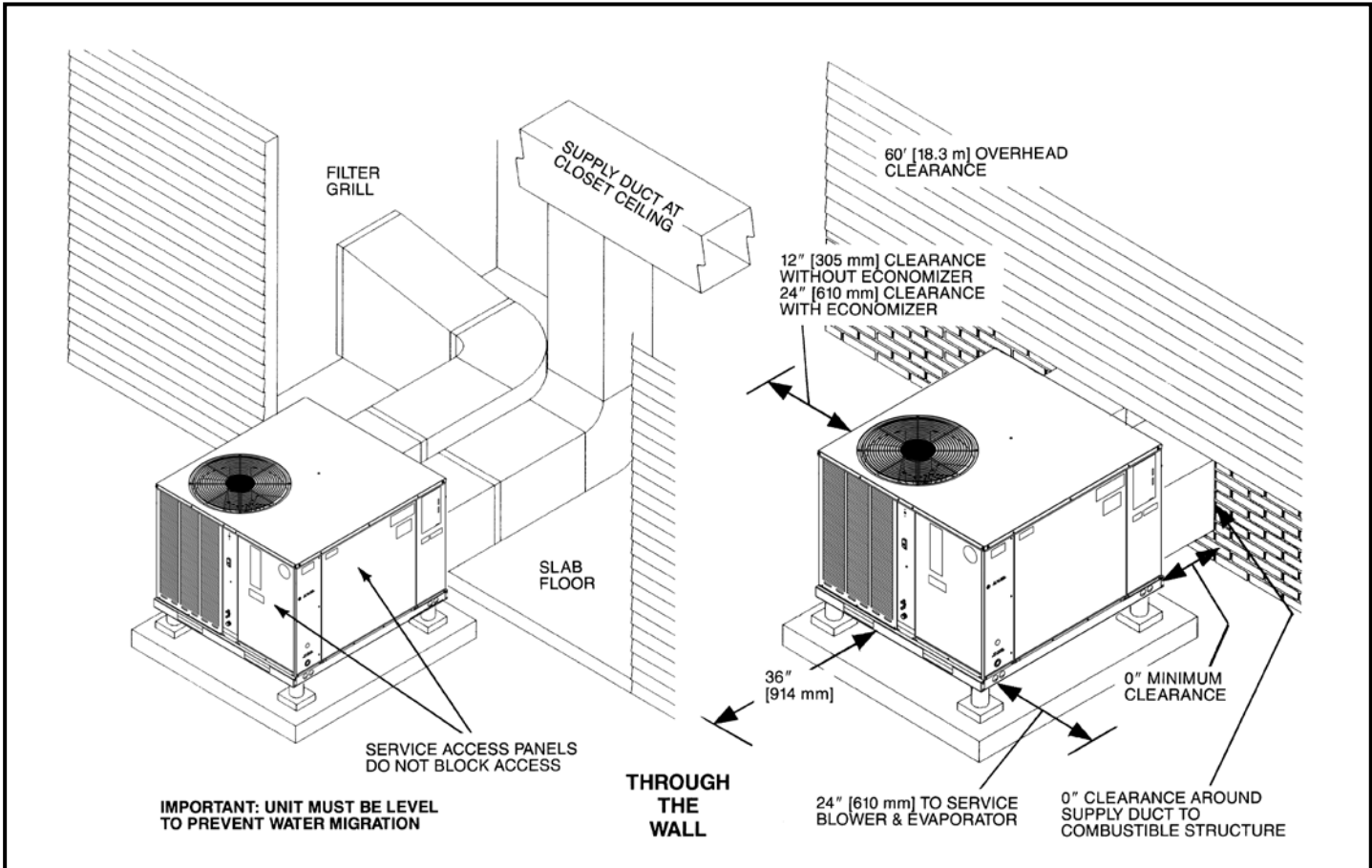

Illustration
ST-A1334-02

[] Designates Metric Conversions

Model RHPX	Height
036, 048, 060	41



[] Designates Metric Conversions

NOMINAL SIZES 3–5 TONS [10.6–17.6 kW]

Model RHPXYC Series	RHPXYC036ACT	RHPXYC036ADT	RHPXYC036AJT
			CONTINUED →
Cooling Performance¹			
Nominal Cooling Capacity Btu/h [kW]	36000 [10.55]	36000 [10.55]	36000 [10.55]
EER2/SEER2 ²	11.5/15.2	11.5/15.2	11.5/15.2
Nominal CFM/AHRI Rated CFM [L/s]	1200/1230 [566/580]	1200/1230 [566/580]	1200/1230 [566/580]
AHRI Net Cooling Capacity Btu/h [kW]	35200 [10.32]	35200 [10.32]	35200 [10.32]
Net Sensible Capacity Btu/h [kW]	26400 [7.74]	26400 [7.74]	26400 [7.74]
Net Latent Capacity Btu/h [kW]	8800 [2.58]	8800 [2.58]	8800 [2.58]
Net System Power kW	3.32	3.32	3.32
Heating Performance (Heat Pumps)			
High Temp. Btu/h [kW] Rating	34200 [10.02]	34200 [10.02]	34200 [10.02]
High Temp System Power kW/COP	2.64 / 3.8	2.64 / 3.8	2.64 / 3.8
Low Temp. Btu/h [kW] Rating	19400 [5.69]	19400 [5.69]	19400 [5.69]
Low Temp System Power kW/COP	2.47 / 2.3	2.47 / 2.3	2.47 / 2.3
HSPF2 ² (Btu/h/Watts-hr)	7.2	7.2	7.2
Compressor			
No./Stg/Type	1/2/scroll	1/2/scroll	1/2/scroll
Outdoor Sound Rating (dB)³			
	78	78	78
Outdoor Coil—Fin Type			
Tube Type	MicroChannel	MicroChannel	MicroChannel
Rifled: Tube Size OD or MicroChannel: Depth in. [mm]	0.63 [16.00]	0.63 [16.00]	0.63 [16.00]
Face Area sq. ft. [sq. m]	16.48 [1.53]	16.48 [1.53]	16.48 [1.53]
Rows/FPI [FPcm]	1 / 16 [6]	1 / 16 [6]	1 / 16 [6]
Indoor Coil—Fin Type			
Tube Type	MicroChannel	MicroChannel	MicroChannel
Rifled: Tube Size OD or MicroChannel: Depth in. [mm]	1.00 [25.40]	1.00 [25.40]	1.00 [25.40]
Face Area sq. ft. [sq. m]	7.6 [0.71]	7.6 [0.71]	7.6 [0.71]
Rows/FPI [FPcm]	1 / 20 [8]	1 / 20 [8]	1 / 20 [8]
Refrigerant Control	TXV	TXV	TXV
Drain Connection No./Size in. [mm]	1 / 0.75 [19.0]	1 / 0.75 [19.0]	1 / 0.75 [19.0]
Outdoor Fan—Type			
No. Used/Diameter in. [mm]	Propeller 1/24 [610]	Propeller 1/24 [610]	Propeller 1/24 [610]
Drive Type/No. Speeds	Direct/Single Speed	Direct/Single Speed	Direct/Single Speed
CFM [L/s]	4300 [2029]	4300 [2029]	4300 [2029]
No. Motors/HP	1 at 1/3	1 at 1/3	1 at 1/3
Motor RPM	825	825	825
Indoor Fan—Type			
No. Used/Diameter in. [mm]	Constant Torque 1/11x9 [279x229]	Constant Torque 1/11x9 [279x229]	Constant Torque 1/11x9 [279x229]
Drive Type	Direct	Direct	Direct
No. Speeds	Multiple Speed	Multiple Speed	Multiple Speed
No. Motors	1	1	1
Motor HP	1/2	3/4	1/2
Motor RPM	1200	1200	1200
Motor Frame Size	48	48	48
Filter—Type			
Furnished	Field Supplied No	Field Supplied No	Field Supplied No
(NO.) Size Recommended in. [mm x mm x mm]	(2) 1x16x30 [25x406x762]	(2) 1x16x30 [25x406x762]	(2) 1x16x30 [25x406x762]
Refrigerant Charge Oz. [g]			
	80.0 [2268.0]	80.0 [2268.0]	80.0 [2268.0]
Weights			
Net Weight lbs. [kg]	439 [199]	439 [199]	439 [199]
Ship Weight lbs. [kg]	449 [204]	449 [204]	449 [204]

See Page 11 for Notes.

[] Designates Metric Conversions

NOMINAL SIZES 3–5 TONS [10.6–17.6 kW]

Model RHPXYC Series	RHPXYC048ACT	RHPXYC048ADT	RHPXYC048AJT
Cooling Performance¹			CONTINUED →
Nominal Cooling Capacity Btu/h [kW]	48000 [14.07]	48000 [14.07]	48000 [14.07]
EER2/SEER2 ²	11.5/15.2	11.5/15.2	11.5/15.2
Nominal CFM/AHRI Rated CFM [L/s]	1600/1430 [755/675]	1600/1430 [755/675]	1600/1430 [755/675]
AHRI Net Cooling Capacity Btu/h [kW]	47000 [13.77]	47000 [13.77]	47000 [13.77]
Net Sensible Capacity Btu/h [kW]	35200 [10.32]	35200 [10.32]	35200 [10.32]
Net Latent Capacity Btu/h [kW]	11800 [3.46]	11800 [3.46]	11800 [3.46]
Net System Power kW	4.43	4.43	4.43
Heating Performance (Heat Pumps)			
High Temp. Btu/h [kW] Rating	45500 [13.34]	45500 [13.34]	45500 [13.34]
High Temp System Power kW/COP	3.65 / 3.65	3.65 / 3.65	3.65 / 3.65
Low Temp. Btu/h [kW] Rating	24600 [7.21]	24600 [7.21]	24600 [7.21]
Low Temp System Power kW/COP	3.11 / 2.32	3.11 / 2.32	3.11 / 2.32
HSPF2 ² (Btu/h/Watts-hr)	7.2	7.2	7.2
Compressor			
No./Stg/Type	1/2/scroll	1/2/scroll	1/2/scroll
Outdoor Sound Rating (dB)³	80	80	80
Outdoor Coil—Fin Type	MicroChannel	MicroChannel	MicroChannel
Tube Type	MicroChannel	MicroChannel	MicroChannel
Rifled: Tube Size OD or MicroChannel: Depth in. [mm]	1.00 [25.40]	1.00 [25.40]	1.00 [25.40]
Face Area sq. ft. [sq. m]	16.29 [1.51]	16.29 [1.51]	16.29 [1.51]
Rows/FPI [FPcm]	1 / 16 [6]	1 / 16 [6]	1 / 16 [6]
Indoor Coil—Fin Type	MicroChannel	MicroChannel	MicroChannel
Tube Type	MicroChannel	MicroChannel	MicroChannel
Rifled: Tube Size OD or MicroChannel: Depth in. [mm]	1.00 [25.40]	1.00 [25.40]	1.00 [25.40]
Face Area sq. ft. [sq. m]	7.6 [0.71]	7.6 [0.71]	7.6 [0.71]
Rows/FPI [FPcm]	1 / 20 [8]	1 / 20 [8]	1 / 20 [8]
Refrigerant Control	TXV	TXV	TXV
Drain Connection No./Size in. [mm]	1 / 0.75 [19.0]	1 / 0.75 [19.0]	1 / 0.75 [19.0]
Outdoor Fan—Type	Propeller	Propeller	Propeller
No. Used/Diameter in. [mm]	1/24 [610]	1/24 [610]	1/24 [610]
Drive Type/No. Speeds	Direct/Single Speed	Direct/Single Speed	Direct/Single Speed
CFM [L/s]	4100 [1935]	4100 [1935]	4100 [1935]
No. Motors/HP	1 at 1/3	1 at 1/3	1 at 1/3
Motor RPM	825	825	825
Indoor Fan—Type	Constant Torque	Constant Torque	Constant Torque
No. Used/Diameter in. [mm]	1/11x9 [279x229]	1/11x9 [279x229]	1/11x9 [279x229]
Drive Type	Direct	Direct	Direct
No. Speeds	Multiple Speed	Multiple Speed	Multiple Speed
No. Motors	1	1	1
Motor HP	3/4	3/4	3/4
Motor RPM	1200	1200	1200
Motor Frame Size	48	48	48
Filter—Type	Field Supplied	Field Supplied	Field Supplied
Furnished	No	No	No
(NO.) Size Recommended in. [mm x mm x mm]	(2) 1x16x30 [25x406x762]	(2) 1x16x30 [25x406x762]	(2) 1x16x30 [25x406x762]
Refrigerant Charge Oz. [g]	128.0 [3628.7]	128.0 [3628.7]	128.0 [3628.7]
Weights			
Net Weight lbs. [kg]	465 [211]	465 [211]	465 [211]
Ship Weight lbs. [kg]	475 [215]	475 [215]	475 [215]

See Page 11 for Notes.

[] Designates Metric Conversions

NOMINAL SIZES 3–5 TONS [10.6–17.6 kW]

Model RHPXYC Series	RHPXYC060ACT	RHPXYC060ADT	RHPXYC060AJT
Cooling Performance¹			
Nominal Cooling Capacity Btu/h [kW]	60000 [17.58]	60000 [17.58]	60000 [17.58]
EER2/SEER2 ²	11.0/15.2	11.0/15.2	11.0/15.2
Nominal CFM/AHRI Rated CFM [L/s]	2000/1820 [944/859]	2000/1820 [944/859]	2000/1820 [944/859]
AHRI Net Cooling Capacity Btu/h [kW]	58000 [17]	58000 [17]	58000 [17]
Net Sensible Capacity Btu/h [kW]	43500 [12.75]	43500 [12.75]	43500 [12.75]
Net Latent Capacity Btu/h [kW]	14500 [4.25]	14500 [4.25]	14500 [4.25]
Net System Power kW	5.47	5.47	5.47
Heating Performance (Heat Pumps)			
High Temp. Btu/h [kW] Rating	55500 [16.27]	55500 [16.27]	55500 [16.27]
High Temp System Power kW/COP	4.46 / 3.65	4.46 / 3.65	4.46 / 3.65
Low Temp. Btu/h [kW] Rating	30200 [8.85]	30200 [8.85]	30200 [8.85]
Low Temp System Power kW/COP	3.93 / 2.25	3.93 / 2.25	3.93 / 2.25
HSPF2 ² (Btu/h/Watts-hr)	7.2	7.2	7.2
Compressor			
No./Stg/Type	1/2/scroll	1/2/scroll	1/2/scroll
Outdoor Sound Rating (dB)³			
	81	81	81
Outdoor Coil—Fin Type			
Tube Type	MicroChannel	MicroChannel	MicroChannel
Rifled: Tube Size OD or MicroChannel: Depth in. [mm]	1.26 [32.00]	1.26 [32.00]	1.26 [32.00]
Face Area sq. ft. [sq. m]	16.19 [1.50]	16.19 [1.50]	16.19 [1.50]
Rows/FPI [FPcm]	1 / 16 [6]	1 / 16 [6]	1 / 16 [6]
Indoor Coil—Fin Type			
Tube Type	MicroChannel	MicroChannel	MicroChannel
Rifled: Tube Size OD or MicroChannel: Depth in. [mm]	1.26 [32.00]	1.26 [32.00]	1.26 [32.00]
Face Area sq. ft. [sq. m]	7.6 [0.71]	7.6 [0.71]	7.6 [0.71]
Rows/FPI [FPcm]	1 / 20 [8]	1 / 20 [8]	1 / 20 [8]
Refrigerant Control	TXV	TXV	TXV
Drain Connection No./Size in. [mm]	1 / 0.75 [19.0]	1 / 0.75 [19.0]	1 / 0.75 [19.0]
Outdoor Fan—Type			
No. Used/Diameter in. [mm]	1/24 [610]	1/24 [610]	1/24 [610]
Drive Type/No. Speeds	Direct/Dual Speed	Direct/Dual Speed	Direct/Dual Speed
CFM [L/s]	4300 [2029]	4300 [2029]	4300 [2029]
No. Motors/HP	1 at 1/2	1 at 1/2	1 at 1/2
Motor RPM	740/935	740/935	740/935
Indoor Fan—Type			
No. Used/Diameter in. [mm]	1/11x9 [279x229]	1/11x9 [279x229]	1/11x9 [279x229]
Drive Type	Direct	Direct	Direct
No. Speeds	Multiple Speed	Multiple Speed	Multiple Speed
No. Motors	1	1	1
Motor HP	1	1	1
Motor RPM	1200	1200	1200
Motor Frame Size	48	48	48
Filter—Type			
Furnished	No	No	No
(NO.) Size Recommended in. [mm x mm x mm]	(2) 1x16x30 [25x406x762]	(2) 1x16x30 [25x406x762]	(2) 1x16x30 [25x406x762]
Refrigerant Charge Oz. [g]			
	139.0 [3940.6]	139.0 [3940.6]	139.0 [3940.6]
Weights			
Net Weight lbs. [kg]	518 [235]	518 [235]	518 [235]
Ship Weight lbs. [kg]	528 [239]	528 [239]	528 [239]

See Page 11 for Notes.

[] Designates Metric Conversions

NOTES:

1. Cooling Performance is rated at 95°F ambient, 80°F entering dry bulb, 67°F entering wet bulb. Gross capacity does not include the effect of fan motor heat. AHRI capacity is net and includes the effect of fan motor heat. Units are suitable for operation to $\pm 20\%$ of nominal cfm. Units are certified in accordance with the Unitary Air Conditioner Equipment certification program, which is based on AHRI Standard 210/240 or 360.
2. EER2/SEER2 and HSPF2 are rated at AHRI conditions and in accordance with DOE test procedures.
3. Outdoor Sound Rating shown is tested in accordance with AHRI Standard 270.

COOLING PERFORMANCE DATA—RHPXYC036

wbE		ENTERING INDOOR AIR @ 80°F [26.7°C] dbE ①									
		71°F [21.7°C]			67°F [19.4°C]			63°F [17.2°C]			
CFM [L/s]		1350 [637]	1225 [578]	1050 [496]	1350 [637]	1225 [578]	1050 [496]	1350 [637]	1225 [578]	1050 [496]	
DR		.05	.09	.12	.05	.09	.12	.05	.09	.12	
OUTDOOR DRY BULB TEMPERATURE °F [°C]	75 [23.9]	Total kBtu/h [kW] Sens kBtu/h [kW] Power	50.7 [14.9] 29.0 [8.5] 2.5	49.8 [14.6] 27.7 [8.1] 2.5	48.5 [14.2] 25.8 [7.6] 2.5	42.2 [12.4] 31.6 [9.3] 2.5	41.4 [12.1] 30.1 [8.8] 2.5	40.3 [11.8] 28.1 [8.2] 2.5	38.6 [11.3] 33.9 [9.9] 2.5	37.9 [11.1] 32.4 [9.5] 2.5	36.9 [10.8] 30.2 [8.9] 2.5
	80 [26.7]	Total kBtu/h [kW] Sens kBtu/h [kW] Power	49.7 [14.6] 28.5 [8.4] 2.7	48.8 [14.3] 27.2 [8.0] 2.6	47.5 [13.9] 25.4 [7.4] 2.6	41.2 [12.1] 31.1 [9.1] 2.6	40.4 [11.8] 29.7 [8.7] 2.6	39.4 [11.5] 27.7 [8.1] 2.6	37.6 [11.0] 33.5 [9.8] 2.6	36.9 [10.8] 31.9 [9.3] 2.6	35.9 [10.5] 29.8 [8.7] 2.6
	85 [29.4]	Total kBtu/h [kW] Sens kBtu/h [kW] Power	48.7 [14.3] 28.0 [8.2] 2.8	47.8 [14.0] 26.8 [7.9] 2.7	46.6 [13.7] 25.0 [7.3] 2.7	40.2 [11.8] 30.6 [9.0] 2.7	39.4 [11.5] 29.2 [8.6] 2.7	38.4 [11.3] 27.3 [8.0] 2.7	36.6 [10.7] 33.0 [9.7] 2.7	35.9 [10.5] 31.5 [9.2] 2.7	35.0 [10.3] 29.4 [8.6] 2.7
	90 [32.2]	Total kBtu/h [kW] Sens kBtu/h [kW] Power	47.7 [14.0] 27.6 [8.1] 2.9	46.8 [13.7] 26.3 [7.7] 2.9	45.6 [13.4] 24.6 [7.2] 2.8	39.1 [11.5] 30.2 [8.9] 2.9	38.4 [11.3] 28.8 [8.4] 2.8	37.4 [11.0] 26.9 [7.9] 2.8	35.6 [10.4] 32.5 [9.5] 2.8	34.9 [10.2] 31.0 [9.1] 2.8	34.0 [10.0] 29.0 [8.5] 2.8
	95 [35.0]	Total kBtu/h [kW] Sens kBtu/h [kW] Power	46.6 [13.7] 27.1 [7.9] 3.0	45.8 [13.4] 25.9 [7.6] 3.0	44.6 [13.1] 24.2 [7.1] 3.0	38.1 [11.2] 29.7 [8.7] 3.0	37.4 [11.0] 28.4 [8.3] 3.0	36.4 [10.7] 26.5 [7.8] 2.9	34.5 [10.1] 32.1 [9.4] 3.0	33.9 [9.9] 30.6 [9] 2.9	33.0 [9.7] 28.6 [8.4] 2.9
	100 [37.8]	Total kBtu/h [kW] Sens kBtu/h [kW] Power	45.5 [13.3] 26.6 [7.8] 3.2	44.7 [13.1] 25.4 [7.4] 3.1	43.5 [12.7] 23.7 [6.9] 3.1	37.0 [10.8] 29.2 [8.6] 3.1	36.3 [10.6] 27.9 [8.2] 3.1	35.4 [10.4] 26.1 [7.6] 3.1	33.4 [9.8] 31.6 [9.3] 3.1	32.8 [9.6] 30.2 [8.9] 3.1	31.9 [9.3] 28.2 [8.3] 3.0
	105 [40.6]	Total kBtu/h [kW] Sens kBtu/h [kW] Power	44.4 [13.0] 26.2 [7.7] 3.3	43.6 [12.8] 25.0 [7.3] 3.3	42.5 [12.5] 23.3 [6.8] 3.2	35.9 [10.5] 28.8 [8.4] 3.3	35.2 [10.3] 27.5 [8.1] 3.3	34.3 [10.1] 25.6 [7.5] 3.2	32.3 [9.5] 31.1 [9.1] 3.3	31.7 [9.3] 29.7 [8.7] 3.2	30.9 [9.1] 27.7 [8.1] 3.2
	110 [43.3]	Total kBtu/h [kW] Sens kBtu/h [kW] Power	43.3 [12.7] 25.7 [7.5] 3.5	42.5 [12.5] 24.6 [7.2] 3.4	41.4 [12.1] 22.9 [6.7] 3.4	34.7 [10.2] 28.3 [8.3] 3.4	34.1 [10.0] 27.0 [7.9] 3.4	33.2 [9.7] 25.2 [7.4] 3.4	31.1 [9.1] 30.7 [9.0] 3.4	30.6 [9.0] 29.3 [8.6] 3.4	29.8 [8.7] 27.3 [8.0] 3.3
	115 [46.1]	Total kBtu/h [kW] Sens kBtu/h [kW] Power	42.1 [12.3] 25.3 [7.4] 3.6	41.3 [12.1] 24.1 [7.1] 3.6	40.3 [11.8] 22.5 [6.6] 3.6	33.6 [9.8] 27.9 [8.2] 3.6	32.9 [9.6] 26.6 [7.8] 3.6	32.1 [9.4] 24.8 [7.3] 3.5	30.0 [8.8] 30.0 [8.8] 3.6	29.4 [8.6] 28.8 [8.4] 3.6	28.7 [8.4] 26.9 [7.9] 3.5
	120 [48.9]	Total kBtu/h [kW] Sens kBtu/h [kW] Power	40.9 [12.0] 24.8 [7.3] 3.8	40.1 [11.8] 23.7 [6.9] 3.8	39.1 [11.5] 22.1 [6.5] 3.7	32.4 [9.5] 27.4 [8.0] 3.8	31.8 [9.3] 26.2 [7.7] 3.8	30.9 [9.1] 24.4 [7.2] 3.7	28.8 [8.4] 28.8 [8.4] 3.8	28.2 [8.3] 28.2 [8.3] 3.7	27.5 [8.1] 26.5 [7.8] 3.7
125 [51.7]	Total kBtu/h [kW] Sens kBtu/h [kW] Power	39.7 [11.6] 24.4 [7.2] 4.0	38.9 [11.4] 23.2 [6.8] 4.0	37.9 [11.1] 21.7 [6.4] 3.9	31.1 [9.1] 27.0 [7.9] 4.0	30.6 [9.0] 25.7 [7.5] 3.9	29.8 [8.7] 24.0 [7.0] 3.9	27.5 [8.1] 27.5 [8.1] 3.9	27.0 [7.9] 27.0 [7.9] 3.9	26.3 [7.7] 26.1 [7.6] 3.9	

DR —Depression ratio
dbE —Entering air dry bulb
wbE—Entering air wet bulb

Total —Total capacity x 1000 Btu/h
Sens —Sensible capacity x 1000 Btu/h
Power—kW input

NOTES:

① When the entering air dry bulb is other than 80°F [27°C], adjust the sensible capacity from the table by adding $[1.10 \times \text{CFM} \times (1 - \text{DR}) \times (\text{dbE} - 80)]$.

[] Designates Metric Conversions

HEATING PERFORMANCE DATA—RHPXYC036

IDB		60°F [15.5°C]			70°F [21.1°C]			80°F [26.7°C]			
		CFM [L/s]	1350 [637]	1225 [578]	1050 [496]	1350 [637]	1225 [578]	1050 [496]	1350 [637]	1225 [578]	1050 [496]
O U T D O O R D R Y B U L B T E M P E R A T U R E ° F [° C]	0 [-17.8]	Total kBtu/h [kW] Power	13.6 [4.0] 2.3	13.5 [4.0] 2.3	13.4 [3.9] 2.4	12.8 [3.8] 2.4	12.7 [3.7] 2.4	12.6 [3.7] 2.4	12.1 [3.5] 2.8	12.0 [3.5] 2.8	11.8 [3.5] 2.9
	5 [-15.0]	Total kBtu/h [kW] Power	15.7 [4.6] 2.3	15.6 [4.6] 2.4	15.4 [4.5] 2.4	14.9 [4.4] 2.4	14.8 [4.3] 2.4	14.7 [4.3] 2.5	14.2 [4.2] 2.8	14.0 [4.1] 2.8	13.9 [4.1] 2.9
	10 [-12.2]	Total kBtu/h [kW] Power	17.8 [5.2] 2.3	17.7 [5.2] 2.4	17.5 [5.1] 2.4	17.0 [5.0] 2.4	16.9 [5.0] 2.4	16.7 [4.9] 2.5	16.2 [4.7] 2.8	16.1 [4.7] 2.8	16.0 [4.7] 2.9
	15 [-9.4]	Total kBtu/h [kW] Power	19.9 [5.8] 2.3	19.8 [5.8] 2.4	19.6 [5.7] 2.4	19.1 [5.6] 2.4	19.0 [5.6] 2.4	18.8 [5.5] 2.5	18.3 [5.4] 2.8	18.2 [5.3] 2.8	18.0 [5.3] 2.9
	20 [-6.7]	Total kBtu/h [kW] Power	22.0 [6.4] 2.3	21.8 [6.4] 2.4	21.6 [6.3] 2.4	21.2 [6.2] 2.4	21.1 [6.2] 2.4	20.8 [6.1] 2.5	20.4 [6.0] 2.8	20.3 [5.9] 2.8	20.1 [5.9] 2.9
	25 [-3.9]	Total kBtu/h [kW] Power	24.1 [7.1] 2.3	23.9 [7.0] 2.4	23.7 [6.9] 2.4	23.3 [6.8] 2.4	23.1 [6.8] 2.4	22.9 [6.7] 2.5	22.5 [6.6] 2.8	22.4 [6.6] 2.9	22.1 [6.5] 2.9
	30 [-1.1]	Total kBtu/h [kW] Power	26.2 [7.7] 2.4	26.0 [7.6] 2.4	25.7 [7.5] 2.4	25.4 [7.4] 2.4	25.2 [7.4] 2.4	25.0 [7.3] 2.5	24.6 [7.2] 2.8	24.4 [7.2] 2.9	24.2 [7.1] 2.9
	35 [1.7]	Total kBtu/h [kW] Power	28.3 [8.3] 2.4	28.1 [8.2] 2.4	27.8 [8.1] 2.4	27.5 [8.1] 2.4	27.3 [8.0] 2.5	27 [7.9] 2.5	26.7 [7.8] 2.8	26.5 [7.8] 2.9	26.3 [7.7] 2.9
	40 [4.4]	Total kBtu/h [kW] Power	30.4 [8.9] 2.4	30.1 [8.8] 2.4	29.8 [8.7] 2.4	29.6 [8.7] 2.4	29.4 [8.6] 2.5	29.1 [8.5] 2.5	28.8 [8.4] 2.8	28.6 [8.4] 2.9	28.3 [8.3] 2.9
	45 [7.2]	Total kBtu/h [kW] Power	32.5 [9.5] 2.4	32.2 [9.4] 2.4	31.9 [9.3] 2.5	31.7 [9.3] 2.4	31.5 [9.2] 2.5	31.1 [9.1] 2.5	30.9 [9.1] 2.8	30.7 [9.0] 2.9	30.4 [8.9] 2.9
	50 [10.0]	Total kBtu/h [kW] Power	34.6 [10.1] 2.4	34.3 [10.1] 2.4	34.0 [10.0] 2.5	33.8 [9.9] 2.4	33.5 [9.8] 2.5	33.2 [9.7] 2.5	33.0 [9.7] 2.8	32.8 [9.6] 2.9	32.4 [9.5] 2.9

IDB—Indoor air dry bulb

[] Designates Metric Conversions

COOLING PERFORMANCE DATA—RHPXYC048

wbE		ENTERING INDOOR AIR @ 80°F [26.7°C] dbE ①									
		71°F [21.7°C]			67°F [19.4°C]			63°F [17.2°C]			
CFM [L/s]		1800 [850]	1425 [673]	1400 [661]	1800 [850]	1425 [673]	1400 [661]	1800 [850]	1425 [673]	1400 [661]	
DR ①		.05	.09	.12	.05	.09	.12	.05	.09	.12	
OUTDOOR DRY BULB TEMPERATURE	75 [23.9]	Total kBtu/h [kW] Sens kBtu/h [kW] Power	59.6 [17.5] 35.4 [10.4] 3.4	56.8 [16.6] 31.5 [9.2] 3.3	56.7 [16.6] 31.3 [9.2] 3.3	55.8 [16.4] 41.3 [12.1] 3.3	53.2 [15.6] 36.8 [10.8] 3.3	53.1 [15.6] 36.5 [10.7] 3.3	52.5 [15.4] 47.4 [13.9] 3.3	50.1 [14.7] 42.2 [12.4] 3.2	49.9 [14.6] 41.8 [12.3] 3.2
	80 [26.7]	Total kBtu/h [kW] Sens kBtu/h [kW] Power	58.3 [17.1] 34.7 [10.2] 3.5	55.6 [16.3] 30.9 [9.1] 3.4	55.4 [16.2] 30.6 [9.0] 3.4	54.5 [16.0] 40.6 [11.9] 3.5	52.0 [15.2] 36.2 [10.6] 3.4	51.8 [15.2] 35.9 [10.5] 3.4	51.2 [15.0] 46.6 [13.7] 3.5	48.9 [14.3] 41.5 [12.2] 3.4	48.7 [14.3] 41.2 [12.1] 3.4
	85 [29.4]	Total kBtu/h [kW] Sens kBtu/h [kW] Power	56.9 [16.7] 34.0 [10.0] 3.7	54.3 [15.9] 30.3 [8.9] 3.6	54.2 [15.9] 30.0 [8.8] 3.6	53.2 [15.6] 39.9 [11.7] 3.7	50.7 [14.9] 35.5 [10.4] 3.6	50.6 [14.8] 35.2 [10.3] 3.6	49.9 [14.6] 45.9 [13.5] 3.6	47.6 [14] 40.9 [12] 3.6	47.4 [13.9] 40.6 [11.9] 3.5
	90 [32.2]	Total kBtu/h [kW] Sens kBtu/h [kW] Power	55.5 [16.3] 33.3 [9.8] 3.9	53.0 [15.5] 29.7 [8.7] 3.8	52.8 [15.5] 29.4 [8.6] 3.8	51.7 [15.2] 39.2 [11.5] 3.9	49.4 [14.5] 34.9 [10.2] 3.8	49.2 [14.4] 34.6 [10.1] 3.8	48.5 [14.2] 45.2 [13.2] 3.8	46.3 [13.6] 40.3 [11.8] 3.7	46.1 [13.5] 40 [11.7] 3.7
	95 [35.0]	Total kBtu/h [kW] Sens kBtu/h [kW] Power	54.1 [15.9] 32.6 [9.6] 4.1	51.6 [15.1] 29.0 [8.5] 4.0	51.4 [15.1] 28.8 [8.4] 4.0	50.3 [14.7] 38.5 [11.3] 4.1	48.0 [14.1] 34.3 [10.1] 4.0	47.8 [14.0] 34.0 [10.0] 4.0	47.0 [13.8] 44.6 [13.1] 4.0	44.9 [13.2] 39.7 [11.6] 3.9	44.7 [13.1] 39.4 [11.5] 3.9
	100 [37.8]	Total kBtu/h [kW] Sens kBtu/h [kW] Power	52.5 [15.4] 31.9 [9.3] 4.3	50.1 [14.7] 28.5 [8.4] 4.2	50.0 [14.7] 28.2 [8.3] 4.2	48.7 [14.3] 37.9 [11.1] 4.3	46.5 [13.6] 33.7 [9.9] 4.2	46.4 [13.6] 33.4 [9.8] 4.2	45.5 [13.3] 43.9 [12.9] 4.3	43.4 [12.7] 39.1 [11.5] 4.2	43.2 [12.7] 38.8 [11.4] 4.2
	105 [40.6]	Total kBtu/h [kW] Sens kBtu/h [kW] Power	50.9 [14.9] 31.3 [9.2] 4.6	48.6 [14.2] 27.9 [8.2] 4.5	48.4 [14.2] 27.6 [8.1] 4.5	47.1 [13.8] 37.2 [10.9] 4.6	45.0 [13.2] 33.1 [9.7] 4.5	44.8 [13.1] 32.9 [9.6] 4.4	43.9 [12.9] 43.3 [12.7] 4.5	41.9 [12.3] 38.5 [11.3] 4.4	41.7 [12.2] 38.2 [11.2] 4.4
	110 [43.3]	Total kBtu/h [kW] Sens kBtu/h [kW] Power	49.3 [14.4] 30.7 [9.0] 4.9	47.0 [13.8] 27.3 [8.0] 4.8	46.9 [13.7] 27.1 [7.9] 4.7	45.5 [13.3] 36.6 [10.7] 4.8	43.4 [12.7] 32.6 [9.6] 4.7	43.2 [12.7] 32.3 [9.5] 4.7	42.2 [12.4] 42.2 [12.4] 4.8	40.3 [11.8] 38.0 [11.1] 4.7	40.1 [11.8] 37.6 [11.0] 4.7
	115 [46.1]	Total kBtu/h [kW] Sens kBtu/h [kW] Power	47.5 [13.9] 30.0 [8.8] 5.2	45.3 [13.3] 26.8 [7.9] 5.0	45.2 [13.2] 26.5 [7.8] 5.0	43.7 [12.8] 36.0 [10.6] 5.1	41.7 [12.2] 32.0 [9.4] 5.0	41.6 [12.2] 31.8 [9.3] 5.0	40.5 [11.9] 40.5 [11.9] 5.1	38.6 [11.3] 37.4 [11.0] 5.0	38.5 [11.3] 37.1 [10.9] 5.0
	120 [48.9]	Total kBtu/h [kW] Sens kBtu/h [kW] Power	45.7 [13.4] 29.4 [8.6] 5.5	43.6 [12.8] 26.2 [7.7] 5.3	43.5 [12.7] 26.0 [7.6] 5.3	41.9 [12.3] 35.3 [10.3] 5.4	40.0 [11.7] 31.5 [9.2] 5.3	39.9 [11.7] 31.2 [9.1] 5.3	38.7 [11.3] 38.7 [11.3] 5.4	36.9 [10.8] 36.9 [10.8] 5.3	36.8 [10.8] 36.6 [10.7] 5.3
125 [51.7]	Total kBtu/h [kW] Sens kBtu/h [kW] Power	43.9 [12.9] 28.8 [8.4] 5.8	41.9 [12.3] 25.7 [7.5] 5.7	41.7 [12.2] 25.5 [7.5] 5.7	40.1 [11.8] 34.8 [10.2] 5.8	38.2 [11.2] 31.0 [9.1] 5.6	38.1 [11.2] 30.7 [9.0] 5.6	36.8 [10.8] 36.8 [10.8] 5.7	35.1 [10.3] 35.1 [10.3] 5.6	35.0 [10.3] 35.0 [10.3] 5.6	

DR —Depression ratio
dbE —Entering air dry bulb
wbE—Entering air wet bulb

Total —Total capacity x 1000 Btu/h
Sens —Sensible capacity x 1000 Btu/h
Power—kW input

NOTES:

① When the entering air dry bulb is other than 80°F [27°C], adjust the sensible capacity from the table by adding [1.10 x CFM x (1 – DR) x (dbE – 80)].

[] Designates Metric Conversions

HEATING PERFORMANCE DATA—RHPXYC048

IDB		60°F [15.5°C]			70°F [21.1°C]			80°F [26.7°C]			
		CFM [L/s]	1800 [850]	1425 [673]	1400 [661]	1800 [850]	1425 [673]	1400 [661]	1800 [850]	1425 [673]	1400 [661]
O U T D O O R D R Y B U L B T E M P E R A T U R E ° F [° C]	0 [-17.8]	Total kBtu/h [kW] Power	18.8 [5.5] 3.0	18.5 [5.4] 3.1	18.4 [5.4] 3.1	17.9 [5.2] 3.1	17.5 [5.1] 3.2	17.5 [5.1] 3.2	16.9 [5.0] 3.6	16.6 [4.9] 3.8	16.6 [4.9] 3.8
	5 [-15]	Total kBtu/h [kW] Power	21.5 [6.3] 3.0	21.1 [6.2] 3.1	21.1 [6.2] 3.1	20.6 [6.0] 3.1	20.2 [5.9] 3.2	20.1 [5.9] 3.2	19.6 [5.7] 3.7	19.2 [5.6] 3.8	19.2 [5.6] 3.8
	10 [-12.2]	Total kBtu/h [kW] Power	24.2 [7.1] 3.0	23.7 [6.9] 3.1	23.7 [6.9] 3.1	23.2 [6.8] 3.1	22.8 [6.7] 3.2	22.8 [6.7] 3.2	22.3 [6.5] 3.7	21.9 [6.4] 3.8	21.9 [6.4] 3.8
	15 [-9.4]	Total kBtu/h [kW] Power	26.9 [7.9] 3.0	26.4 [7.7] 3.1	26.4 [7.7] 3.1	25.9 [7.6] 3.1	25.5 [7.5] 3.2	25.4 [7.4] 3.2	25.0 [7.3] 3.7	24.5 [7.2] 3.8	24.5 [7.2] 3.8
	20 [-6.7]	Total kBtu/h [kW] Power	29.6 [8.7] 3.0	29.0 [8.5] 3.1	29.0 [8.5] 3.2	28.6 [8.4] 3.1	28.1 [8.2] 3.2	28.1 [8.2] 3.2	27.7 [8.1] 3.7	27.2 [8.0] 3.8	27.2 [8.0] 3.8
	25 [-3.9]	Total kBtu/h [kW] Power	32.3 [9.5] 3.0	31.7 [9.3] 3.2	31.6 [9.3] 3.2	31.3 [9.2] 3.1	30.8 [9.0] 3.2	30.7 [9.0] 3.2	30.4 [8.9] 3.7	29.8 [8.7] 3.8	29.8 [8.7] 3.8
	30 [-1.1]	Total kBtu/h [kW] Power	35.0 [10.3] 3.1	34.3 [10.1] 3.2	34.3 [10.1] 3.2	34.0 [10.0] 3.1	33.4 [9.8] 3.2	33.4 [9.8] 3.2	33.1 [9.7] 3.7	32.5 [9.5] 3.8	32.4 [9.5] 3.8
	35 [1.7]	Total kBtu/h [kW] Power	37.7 [11.0] 3.1	37.0 [10.8] 3.2	36.9 [10.8] 3.2	36.7 [10.8] 3.1	36.1 [10.6] 3.2	36.0 [10.6] 3.2	35.8 [10.5] 3.7	35.1 [10.3] 3.8	35.1 [10.3] 3.8
	40 [4.4]	Total kBtu/h [kW] Power	40.4 [11.8] 3.1	39.6 [11.6] 3.2	39.6 [11.6] 3.2	39.4 [11.5] 3.1	38.7 [11.3] 3.2	38.6 [11.3] 3.2	38.5 [11.3] 3.7	37.8 [11.1] 3.8	37.7 [11.0] 3.8
	45 [7.2]	Total kBtu/h [kW] Power	43.1 [12.6] 3.1	42.3 [12.4] 3.2	42.2 [12.4] 3.2	42.1 [12.3] 3.1	41.3 [12.1] 3.2	41.3 [12.1] 3.2	41.2 [12.1] 3.7	40.4 [11.8] 3.8	40.4 [11.8] 3.8
	50 [10.0]	Total kBtu/h [kW] Power	45.8 [13.4] 3.1	44.9 [13.2] 3.2	44.9 [13.2] 3.2	44.8 [13.1] 3.1	44.0 [12.9] 3.2	43.9 [12.9] 3.2	43.9 [12.9] 3.7	43.1 [12.6] 3.8	43.0 [12.6] 3.8

IDB—Indoor air dry bulb

[] Designates Metric Conversions

COOLING PERFORMANCE DATA—RHPXYC060

wbE		ENTERING INDOOR AIR @ 80°F [26.7°C] dbE ①									
		71°F [21.7°C]			67°F [19.4°C]			63°F [17.2°C]			
CFM [L/s]		2250 [1062]	1825 [861]	1750 [826]	2250 [1062]	1825 [861]	1750 [826]	2250 [1062]	1825 [861]	1750 [826]	
DR ①		.05	.09	.12	.05	.09	.12	.05	.09	.12	
OUTDOOR DRY BULB TEMPERATURE °F [°C]	75 [23.9]	Total kBtu/h [kW] Sens kBtu/h [kW] Power	70.4 [20.6] 41.8 [12.3] 4.3	67.5 [19.8] 37.7 [11.0] 4.2	67.0 [19.6] 37.0 [10.8] 4.2	66.7 [19.5] 49.2 [14.4] 4.3	64.0 [18.8] 44.4 [13.0] 4.2	63.5 [18.6] 43.6 [12.8] 4.2	62.2 [18.2] 55.7 [16.3] 4.2	59.7 [17.5] 50.2 [14.7] 4.1	59.2 [17.4] 49.2 [14.4] 4.1
	80 [26.7]	Total kBtu/h [kW] Sens kBtu/h [kW] Power	69.5 [20.4] 41.6 [12.2] 4.5	66.6 [19.5] 37.5 [11.0] 4.4	66.1 [19.4] 36.8 [10.8] 4.4	65.8 [19.3] 49.1 [14.4] 4.5	63.1 [18.5] 44.3 [13.0] 4.4	62.7 [18.4] 43.4 [12.7] 4.4	61.3 [18.0] 55.5 [16.3] 4.4	58.8 [17.2] 50.0 [14.7] 4.3	58.3 [17.1] 49.1 [14.4] 4.3
	85 [29.4]	Total kBtu/h [kW] Sens kBtu/h [kW] Power	68.3 [20.0] 41.2 [12.1] 4.7	65.5 [19.2] 37.2 [10.9] 4.6	65.0 [19.1] 36.5 [10.7] 4.6	64.6 [18.9] 48.7 [14.3] 4.7	62.0 [18.2] 43.9 [12.9] 4.6	61.5 [18.0] 43.1 [12.6] 4.6	60.1 [17.6] 55.1 [16.1] 4.6	57.7 [16.9] 49.7 [14.6] 4.5	57.2 [16.8] 48.7 [14.3] 4.5
	90 [32.2]	Total kBtu/h [kW] Sens kBtu/h [kW] Power	66.9 [19.6] 40.6 [11.9] 4.9	64.2 [18.8] 36.6 [10.7] 4.8	63.7 [18.7] 35.9 [10.5] 4.8	63.2 [18.5] 48.0 [14.1] 4.9	60.6 [17.8] 43.3 [12.7] 4.8	60.2 [17.6] 42.5 [12.5] 4.8	58.7 [17.2] 54.5 [16.0] 4.8	56.3 [16.5] 49.1 [14.4] 4.7	55.9 [16.4] 48.2 [14.1] 4.7
	95 [35.0]	Total kBtu/h [kW] Sens kBtu/h [kW] Power	65.2 [19.1] 39.7 [11.6] 5.2	62.6 [18.3] 35.8 [10.5] 5.1	62.1 [18.2] 35.1 [10.3] 5.0	61.5 [18.0] 47.2 [13.8] 5.1	59.0 [17.3] 42.6 [12.5] 5.0	58.6 [17.2] 41.8 [12.3] 5.0	57.0 [16.7] 53.6 [15.7] 5.0	54.7 [16.0] 48.4 [14.2] 4.9	54.3 [15.9] 47.4 [13.9] 4.9
	100 [37.8]	Total kBtu/h [kW] Sens kBtu/h [kW] Power	63.3 [18.6] 38.7 [11.3] 5.4	60.7 [17.8] 34.9 [10.2] 5.3	60.3 [17.7] 34.2 [10.0] 5.3	59.6 [17.5] 46.1 [13.5] 5.3	57.2 [16.8] 41.6 [12.2] 5.2	56.8 [16.6] 40.8 [12.0] 5.2	55.1 [16.1] 52.5 [15.4] 5.3	52.9 [15.5] 47.4 [13.9] 5.2	52.5 [15.4] 46.5 [13.6] 5.2
	105 [40.6]	Total kBtu/h [kW] Sens kBtu/h [kW] Power	61.2 [17.9] 37.4 [11.0] 5.6	58.7 [17.2] 33.7 [9.9] 5.5	58.2 [17.1] 33.1 [9.7] 5.5	57.5 [16.9] 44.8 [13.1] 5.6	55.2 [16.2] 40.4 [11.8] 5.5	54.7 [16.0] 39.7 [11.6] 5.4	53.0 [15.5] 51.2 [15.0] 5.5	50.8 [14.9] 46.2 [13.5] 5.4	50.4 [14.8] 45.3 [13.3] 5.4
	110 [43.3]	Total kBtu/h [kW] Sens kBtu/h [kW] Power	58.8 [17.2] 35.8 [10.5] 5.9	56.4 [16.5] 32.3 [9.5] 5.8	56.0 [16.4] 31.7 [9.3] 5.8	55.1 [16.1] 43.3 [12.7] 5.8	52.9 [15.5] 39.1 [11.5] 5.7	52.5 [15.4] 38.3 [11.2] 5.7	50.6 [14.8] 49.7 [14.6] 5.8	48.5 [14.2] 44.8 [13.1] 5.7	48.2 [14.1] 44.0 [12.9] 5.6
	115 [46.1]	Total kBtu/h [kW] Sens kBtu/h [kW] Power	56.1 [16.4] 34.1 [10.0] 6.2	53.9 [15.8] 30.8 [9.0] 6.0	53.4 [15.7] 30.2 [8.9] 6.0	52.5 [15.4] 41.6 [12.2] 6.1	50.3 [14.7] 37.5 [11.0] 6.0	50.0 [14.7] 36.8 [10.8] 6.0	47.9 [14.0] 47.9 [14.0] 6	46.0 [13.5] 43.3 [12.7] 5.9	45.7 [13.4] 42.4 [12.4] 5.9
	120 [48.9]	Total kBtu/h [kW] Sens kBtu/h [kW] Power	53.3 [15.6] 32.1 [9.4] 6.4	51.1 [15.0] 29.0 [8.5] 6.3	50.7 [14.9] 28.4 [8.3] 6.3	49.6 [14.5] 39.6 [11.6] 6.4	47.6 [14.0] 35.7 [10.5] 6.3	47.2 [13.8] 35.0 [10.3] 6.2	45.1 [13.2] 45.1 [13.2] 6.3	43.2 [12.7] 41.5 [12.2] 6.2	42.9 [12.6] 40.7 [11.9] 6.2
	125 [51.7]	Total kBtu/h [kW] Sens kBtu/h [kW] Power	50.1 [14.7] 29.9 [8.8] 6.7	48.1 [14.1] 27.0 [7.9] 6.6	47.7 [14.0] 26.5 [7.8] 6.6	46.5 [13.6] 37.4 [11.0] 6.7	44.6 [13.1] 33.7 [9.9] 6.5	44.3 [13.0] 33.1 [9.7] 6.5	41.9 [12.3] 41.9 [12.3] 6.6	40.2 [11.8] 39.5 [11.6] 6.5	39.9 [11.7] 38.8 [11.4] 6.5

DR —Depression ratio
dbE —Entering air dry bulb
wbE—Entering air wet bulb

Total —Total capacity x 1000 Btu/h
Sens —Sensible capacity x 1000 Btu/h
Power —kW input

NOTES:

① When the entering air dry bulb is other than 80°F [27°C], adjust the sensible capacity from the table by adding [1.10 x CFM x (1 – DR) x (dbE – 80)].

[] Designates Metric Conversions

HEATING PERFORMANCE DATA—RHPXYC060

IDB		60°F [15.5°C]			70°F [21.1°C]			80°F [26.7°C]			
		CFM [L/s]	2250 [1062]	1825 [861]	1750 [826]	2250 [1062]	1825 [861]	1750 [826]	2250 [1062]	1825 [861]	1750 [826]
O U T D O O R D R Y B U L B T E M P E R A T U R E ° F [° C]	0 [-17.8]	Total kBtu/h [kW] Power	26.9 [7.9] 4.0	26.4 [7.7] 4.1	26.3 [7.7] 4.1	25.1 [7.4] 3.9	24.7 [7.2] 4.0	24.6 [7.2] 4.1	23.3 [6.8] 4.6	22.9 [6.7] 4.8	22.9 [6.7] 4.8
	5 [-15]	Total kBtu/h [kW] Power	29.7 [8.7] 3.9	29.2 [8.6] 4.1	29.2 [8.6] 4.1	28.0 [8.2] 3.9	27.5 [8.1] 4.0	27.4 [8.0] 4.1	26.2 [7.7] 4.6	25.8 [7.6] 4.8	25.7 [7.5] 4.8
	10 [-12.2]	Total kBtu/h [kW] Power	32.6 [9.6] 3.9	32.1 [9.4] 4.1	32.0 [9.4] 4.1	30.8 [9.0] 3.9	30.3 [8.9] 4.0	30.2 [8.9] 4.0	29.1 [8.5] 4.6	28.6 [8.4] 4.8	28.5 [8.4] 4.8
	15 [-9.4]	Total kBtu/h [kW] Power	35.5 [10.4] 3.9	34.9 [10.2] 4.1	34.8 [10.2] 4.1	33.7 [9.9] 3.9	33.2 [9.7] 4.0	33.1 [9.7] 4.0	31.9 [9.3] 4.6	31.4 [9.2] 4.8	31.3 [9.2] 4.8
	20 [-6.7]	Total kBtu/h [kW] Power	38.3 [11.2] 3.9	37.7 [11.0] 4.0	37.6 [11.0] 4.1	36.6 [10.7] 3.9	36.0 [10.6] 4.0	35.9 [10.5] 4.0	34.8 [10.2] 4.6	34.2 [10.0] 4.7	34.1 [10.0] 4.8
	25 [-3.9]	Total kBtu/h [kW] Power	41.2 [12.1] 3.9	40.5 [11.9] 4.0	40.4 [11.8] 4.1	39.5 [11.6] 3.9	38.8 [11.4] 4.0	38.7 [11.3] 4.0	37.7 [11.0] 4.6	37.1 [10.9] 4.7	37.0 [10.8] 4.8
	30 [-1.1]	Total kBtu/h [kW] Power	44.1 [12.9] 3.9	43.4 [12.7] 4.0	43.2 [12.7] 4.1	42.3 [12.4] 3.9	41.6 [12.2] 4.0	41.5 [12.2] 4.0	40.6 [11.9] 4.6	39.9 [11.7] 4.7	39.8 [11.7] 4.8
	35 [1.7]	Total kBtu/h [kW] Power	47.0 [13.8] 3.9	46.2 [13.5] 4.0	46.1 [13.5] 4.0	45.2 [13.2] 3.9	44.5 [13.0] 4.0	44.3 [13.0] 4.0	43.4 [12.7] 4.6	42.7 [12.5] 4.7	42.6 [12.5] 4.8
	40 [4.4]	Total kBtu/h [kW] Power	49.8 [14.6] 3.9	49 [14.4] 4.0	48.9 [14.3] 4.0	48.1 [14.1] 3.9	47.3 [13.9] 4.0	47.1 [13.8] 4.0	46.3 [13.6] 4.6	45.5 [13.3] 4.7	45.4 [13.3] 4.7
	45 [7.2]	Total kBtu/h [kW] Power	52.7 [15.4] 3.9	51.8 [15.2] 4.0	51.7 [15.2] 4.0	50.9 [14.9] 3.9	50.1 [14.7] 4.0	50.0 [14.7] 4.0	49.2 [14.4] 4.6	48.4 [14.2] 4.7	48.2 [14.1] 4.7
	50 [10.0]	Total kBtu/h [kW] Power	55.6 [16.3] 3.9	54.7 [16.0] 4.0	54.5 [16.0] 4.0	53.8 [15.8] 3.9	52.9 [15.5] 4.0	52.8 [15.5] 4.0	52.1 [15.3] 4.6	51.2 [15.0] 4.7	51.0 [14.9] 4.7

IDB—Indoor air dry bulb

[] Designates Metric Conversions

INDOOR AIRFLOW PERFORMANCE — RHPXYC

Nominal Cooling Capacity Tons [kW]	Manufacturer Recommended High stage Cooling Airflow (Min/Max)	Blower Size/ Motor HP [W] & # of Speeds	Motor Speed	External Static Pressure - Inches W.C. [kPa]										
				0.1 [.02]	0.2 [.05]	0.3 [.07]	0.4 [.10]	0.5 [.12]	0.6 [.15]	0.7 [.17]	0.8 [.20]	0.9 [.23]	1.0 [.25]	
3.0 [10.55]	1050 CFM / 1350 CFM	12 x 9T Blower 1/2 HP [373W] Ensite Air	Tap 1 Fan only	CFM [l/s]	974 [460]	920 [434]	856 [404]	794 [375]	626 [295]	559 [264]	445 [210]	349 [165]	314 [148]	253 [119]
				RPM	450	502	561	613	711	745	812	852	874	909
				Watts	87	94	103	110	125	131	141	146	149	154
				CFM [l/s]	1157 [546]	1126 [531]	1066 [503]	1014 [479]	958 [452]	850 [401]	733 [346]	692 [327]	622 [294]	535 [252]
				RPM	515	546	599	647	696	779	836	863	931	963
				Watts	133	140	150	160	170	187	200	204	217	225
			Tap 3 Y1	CFM [l/s]	974 [460]	920 [434]	856 [404]	794 [375]	626 [295]	559 [264]	445 [210]	349 [165]	314 [148]	253 [119]
				RPM	450	502	561	613	711	745	812	852	874	909
				Watts	87	94	103	110	125	131	141	146	149	154
				CFM [l/s]	1447 [683]	1413 [667]	1384 [653]	1341 [633]	1294 [611]	1250 [590]	1209 [571]	1163 [549]	1113 [525]	973 [459]
				RPM	614	643	668	709	750	790	828	869	908	1001
				Watts	246	255	263	274	287	300	309	323	336	366
4.0 [14.07]	1400 CFM / 1800 CFM	2 x 9T Blower 3/4 HP [559W] Ensite Air	Tap 5 Max static	CFM [l/s]	1581 [746]	1544 [729]	1497 [707]	1468 [693]	1425 [673]	1382 [652]	1341 [633]	1305 [616]	1262 [596]	1227 [579]
				RPM	649	677	707	740	776	815	853	887	925	959
				Watts	307	317	327	340	352	366	380	390	405	418
				CFM [l/s]	1400 [661]	1202 [567]	1057 [499]	1013 [478]	900 [425]	767 [362]	721 [340]	673 [318]	577 [272]	513 [242]
				RPM	579	588	623	662	737	812	835	865	929	955
				Watts	194	163	154	162	177	193	199	205	218	224
			Tap 1 Fan only	CFM [l/s]	1400 [661]	1202 [567]	1057 [499]	1013 [478]	900 [425]	767 [362]	721 [340]	673 [318]	577 [272]	513 [242]
				RPM	579	588	623	662	737	812	835	865	929	955
				Watts	194	163	154	162	177	193	199	205	218	224
				CFM [l/s]	1400 [661]	1202 [567]	1057 [499]	1013 [478]	900 [425]	767 [362]	721 [340]	673 [318]	577 [272]	513 [242]
				RPM	579	588	623	662	737	812	835	865	929	955
				Watts	194	163	154	162	177	193	199	205	218	224
4.0 [14.07]	1400 CFM / 1800 CFM	2 x 9T Blower 3/4 HP [559W] Ensite Air	Tap 2 Heater Kit	CFM [l/s]	1712 [808]	1682 [794]	1636 [772]	1596 [753]	1545 [729]	1490 [703]	1444 [681]	1405 [663]	1371 [647]	1338 [631]
				RPM	667	697	741	777	818	863	903	935	961	982
				Watts	327	339	356	371	386	405	420	433	444	451
				CFM [l/s]	1962 [926]	1929 [910]	1886 [890]	1850 [873]	1814 [856]	1783 [841]	1752 [827]	1702 [803]	1674 [790]	1629 [769]
				RPM	755	775	806	839	867	902	933	980	1009	1048
				Watts	487	498	512	529	544	561	579	604	619	644
			Tap 4 Y2	CFM [l/s]	1712 [808]	1682 [794]	1636 [772]	1596 [753]	1545 [729]	1490 [703]	1444 [681]	1405 [663]	1371 [647]	1338 [631]
				RPM	667	697	741	777	818	863	903	935	961	982
				Watts	327	339	356	371	386	405	420	433	444	451
				CFM [l/s]	1962 [926]	1929 [910]	1886 [890]	1850 [873]	1814 [856]	1783 [841]	1752 [827]	1702 [803]	1674 [790]	1629 [769]
				RPM	755	775	806	839	867	902	933	980	1009	1048
				Watts	487	498	512	529	544	561	579	604	619	644
Tap 5 Max Static	CFM [l/s]	1712 [808]	1682 [794]	1636 [772]	1596 [753]	1545 [729]	1490 [703]	1444 [681]	1405 [663]	1371 [647]	1338 [631]			
	RPM	667	697	741	777	818	863	903	935	961	982			
	Watts	327	339	356	371	386	405	420	433	444	451			
	CFM [l/s]	1962 [926]	1929 [910]	1886 [890]	1850 [873]	1814 [856]	1783 [841]	1752 [827]	1702 [803]	1674 [790]	1629 [769]			
	RPM	755	775	806	839	867	902	933	980	1009	1048			
	Watts	487	498	512	529	544	561	579	604	619	644			

NOTES: Grey cells indicate airflow outside of manufacturers recommendation.
Do not connect wiring to unspecified speed taps.

[] Designates Metric Conversions

INDOOR AIRFLOW PERFORMANCE — RHPXYC (CONTINUED)

Nominal Cooling Capacity Tons [kW]	Manufacturer Recommended High stage Cooling Airflow (Min/Max)	Blower Size/ Motor HP [W] & # of Speeds	Motor Speed	External Static Pressure - Inches W.C. [kPa] (Side Discharge-Dry Coil)											
				0.1 [.02]	0.2 [.05]	0.3 [.07]	0.4 [.10]	0.5 [.12]	0.6 [.15]	0.7 [.17]	0.8 [.20]	0.9 [.23]	1.0 [.25]		
5.0 [17.58]	1750 CFM / 2250 CFM	12 x 9T Blower 1 HP [746W] Ensife Air	Tap 1 Fan only	CFM [l/s]	1396 [659]	1250 [590]	1199 [566]	1146 [541]	1095 [517]	1037 [489]	857 [404]	785 [370]	745 [352]	698 [329]	
				RPM	585	592	634	676	722	759	868	904	929	968	
			Tap 2 Heater Kit	Watts	186	163	173	182	193	201	227	235	241	250	250
				CFM [l/s]	1396 [659]	1250 [590]	1199 [566]	1146 [541]	1095 [517]	1037 [489]	857 [404]	785 [370]	745 [352]	698 [329]	698 [329]
			Tap 3 Y1	RPM	585	592	634	676	722	759	868	904	929	968	968
				Watts	186	163	173	182	193	201	227	235	241	250	250
			Tap 4 Y2	CFM [l/s]	1468 [693]	1443 [681]	1389 [656]	1344 [634]	1291 [609]	1251 [590]	1205 [569]	1086 [513]	975 [460]	915 [432]	915 [432]
				RPM	609	638	683	722	767	796	831	913	977	1009	1009
			Tap 5 Max static	Watts	213	223	235	246	260	268	279	303	323	332	332
				CFM [l/s]	2095 [989]	2071 [977]	2043 [964]	2018 [952]	1981 [935]	1945 [918]	1913 [903]	1870 [883]	1839 [868]	1800 [850]	1800 [850]
				RPM	808	829	856	877	911	935	970	1002	1029	1069	1069
				Watts	571	581	598	609	628	641	663	678	700	723	723
	CFM [l/s]	2262 [1068]	2245 [1060]	2218 [1047]	2190 [1034]	2158 [1018]	2135 [1008]	2100 [991]	2068 [976]	2002 [945]	1940 [916]	1940 [916]			
	RPM	867	880	897	936	956	985	1017	1043	1076	1094	1094			
	Watts	736	748	760	784	797	818	841	858	865	846	846			

NOTE: Grey cells indicate airflow outside of manufacturers recommendation.
Do not connect wiring to unspecified speed taps.

DOWN DISCHARGE PRESSURE DROP (ADD TO SIDE DISCHARGE EXTERNAL STATIC PRESSURE)			
CFM [L/s]	600 [283]	800 [378]	1000 [472]
Pressure Drop — Inches W.C. [kPa]	0	.02 [.005]	.05 [.012]
		.07 [.017]	.12 [.030]
		.15 [.037]	.17 [.042]
		.18 [.042]	.20 [.048]
		.22 [.051]	.25 [.057]
		.28 [.062]	.32 [.071]
		.38 [.084]	.45 [.101]
		.55 [.112]	.65 [.134]
		.80 [.151]	1.0 [.227]
		1.2 [.274]	1.5 [.331]
		1.8 [.407]	2.2 [.489]
		2.8 [.621]	3.5 [.763]
		4.5 [.984]	5.5 [.121]
		7.0 [.151]	8.5 [.194]
		10.0 [.227]	12.0 [.291]
		15.0 [.331]	18.0 [.444]
		20.0 [.457]	25.0 [.571]
		28.0 [.621]	35.0 [.763]
		38.0 [.844]	45.0 [.101]
		50.0 [.112]	60.0 [.134]
		65.0 [.141]	80.0 [.181]
		80.0 [.181]	100.0 [.227]
		100.0 [.227]	120.0 [.291]
		120.0 [.291]	150.0 [.364]
		150.0 [.364]	180.0 [.444]
		180.0 [.444]	200.0 [.489]
		200.0 [.489]	250.0 [.606]
		250.0 [.606]	300.0 [.723]
		300.0 [.723]	350.0 [.840]
		350.0 [.840]	400.0 [.957]
		400.0 [.957]	450.0 [.1074]
		450.0 [.1074]	500.0 [.1191]
		500.0 [.1191]	550.0 [.1308]
		550.0 [.1308]	600.0 [.1425]
		600.0 [.1425]	650.0 [.1542]
		650.0 [.1542]	700.0 [.1659]
		700.0 [.1659]	750.0 [.1776]
		750.0 [.1776]	800.0 [.1893]
		800.0 [.1893]	850.0 [.2010]
		850.0 [.2010]	900.0 [.2127]
		900.0 [.2127]	950.0 [.2244]
		950.0 [.2244]	1000.0 [.2361]
		1000.0 [.2361]	1050.0 [.2478]
		1050.0 [.2478]	1100.0 [.2595]
		1100.0 [.2595]	1150.0 [.2712]
		1150.0 [.2712]	1200.0 [.2829]
		1200.0 [.2829]	1250.0 [.2946]
		1250.0 [.2946]	1300.0 [.3063]
		1300.0 [.3063]	1350.0 [.3180]
		1350.0 [.3180]	1400.0 [.3297]
		1400.0 [.3297]	1450.0 [.3414]
		1450.0 [.3414]	1500.0 [.3531]
		1500.0 [.3531]	1550.0 [.3648]
		1550.0 [.3648]	1600.0 [.3765]
		1600.0 [.3765]	1650.0 [.3882]
		1650.0 [.3882]	1700.0 [.4000]
		1700.0 [.4000]	1750.0 [.4117]
		1750.0 [.4117]	1800.0 [.4234]
		1800.0 [.4234]	1850.0 [.4351]
		1850.0 [.4351]	1900.0 [.4468]
		1900.0 [.4468]	1950.0 [.4585]
		1950.0 [.4585]	2000.0 [.4702]
		2000.0 [.4702]	2050.0 [.4819]
		2050.0 [.4819]	2100.0 [.4936]
		2100.0 [.4936]	2150.0 [.5053]
		2150.0 [.5053]	2200.0 [.5170]
		2200.0 [.5170]	2250.0 [.5287]
		2250.0 [.5287]	2300.0 [.5404]
		2300.0 [.5404]	2350.0 [.5521]
		2350.0 [.5521]	2400.0 [.5638]
		2400.0 [.5638]	2450.0 [.5755]
		2450.0 [.5755]	2500.0 [.5872]
		2500.0 [.5872]	2550.0 [.5989]
		2550.0 [.5989]	2600.0 [.6106]
		2600.0 [.6106]	2650.0 [.6223]
		2650.0 [.6223]	2700.0 [.6340]
		2700.0 [.6340]	2750.0 [.6457]
		2750.0 [.6457]	2800.0 [.6574]
		2800.0 [.6574]	2850.0 [.6691]
		2850.0 [.6691]	2900.0 [.6808]
		2900.0 [.6808]	2950.0 [.6925]
		2950.0 [.6925]	3000.0 [.7042]
		3000.0 [.7042]	3050.0 [.7159]
		3050.0 [.7159]	3100.0 [.7276]
		3100.0 [.7276]	3150.0 [.7393]
		3150.0 [.7393]	3200.0 [.7510]
		3200.0 [.7510]	3250.0 [.7627]
		3250.0 [.7627]	3300.0 [.7744]
		3300.0 [.7744]	3350.0 [.7861]
		3350.0 [.7861]	3400.0 [.7978]
		3400.0 [.7978]	3450.0 [.8095]
		3450.0 [.8095]	3500.0 [.8212]
		3500.0 [.8212]	3550.0 [.8329]
		3550.0 [.8329]	3600.0 [.8446]
		3600.0 [.8446]	3650.0 [.8563]
		3650.0 [.8563]	3700.0 [.8680]
		3700.0 [.8680]	3750.0 [.8797]
		3750.0 [.8797]	3800.0 [.8914]
		3800.0 [.8914]	3850.0 [.9031]
		3850.0 [.9031]	3900.0 [.9148]
		3900.0 [.9148]	3950.0 [.9265]
		3950.0 [.9265]	4000.0 [.9382]
		4000.0 [.9382]	4050.0 [.9499]
		4050.0 [.9499]	4100.0 [.9616]
		4100.0 [.9616]	4150.0 [.9733]
		4150.0 [.9733]	4200.0 [.9850]
		4200.0 [.9850]	4250.0 [.9967]
		4250.0 [.9967]	4300.0 [1.0084]
		4300.0 [1.0084]	4350.0 [1.0201]
		4350.0 [1.0201]	4400.0 [1.0318]
		4400.0 [1.0318]	4450.0 [1.0435]
		4450.0 [1.0435]	4500.0 [1.0552]
		4500.0 [1.0552]	4550.0 [1.0669]
		4550.0 [1.0669]	4600.0 [1.0786]
		4600.0 [1.0786]	4650.0 [1.0903]
		4650.0 [1.0903]	4700.0 [1.1020]
		4700.0 [1.1020]	4750.0 [1.1137]
		4750.0 [1.1137]	4800.0 [1.1254]
		4800.0 [1.1254]	4850.0 [1.1371]
		4850.0 [1.1371]	4900.0 [1.1488]
		4900.0 [1.1488]	4950.0 [1.1605]
		4950.0 [1.1605]	5000.0 [1.1722]
		5000.0 [1.1722]	5050.0 [1.1839]
		5050.0 [1.1839]	5100.0 [1.1956]
		5100.0 [1.1956]	5150.0 [1.2073]
		5150.0 [1.2073]	5200.0 [1.2190]
		5200.0 [1.2190]	5250.0 [1.2307]
		5250.0 [1.2307]	5300.0 [1.2424]
		5300.0 [1.2424]	5350.0 [1.2541]
		5350.0 [1.2541]	5400.0 [1.2658]
		5400.0 [1.2658]	5450.0 [1.2775]
		5450.0 [1.2775]	5500.0 [1.2892]
		5500.0 [1.2892]	5550.0 [1.3009]
		5550.0 [1.3009]	5600.0 [1.3126]
		5600.0 [1.3126]	5650.0 [1.3243]
		5650.0 [1.3243]	5700.0 [1.3360]
		5700.0 [1.3360]	5750.0 [1.3477]
		5750.0 [1.3477]	5800.0 [1.3594]
		5800.0 [1.3594]	5850.0 [1.3711]
		5850.0 [1.3711]	5900.0 [1.3828]
		5900.0 [1.3828]	5950.0 [1.3945]
		5950.0 [1.3945]	6000.0 [1.4062]
		6000.0 [1.4062]	6050.0 [1.4179]
		6050.0 [1.4179]	6100.0 [1.4296]
		6100.0 [1.4296]	6150.0 [1.4413]
		6150.0 [1.4413]	6200.0 [1.4530]
		6200.0 [1.4530]	6250.0 [1.4647]
		6250.0 [1.4647]	6300.0 [1.4764]
		6300.0 [1.4764]	6350.0 [1.4881]
		6350.0 [1.4881]	6400.0 [1.5000]
		6400.0 [1.5000]	6450.0 [1.5117]
		6450.0 [1.5117]	6500.0 [1.5234]
		6500.0 [1.5234]	6550.0 [1.5351]
		6550.0 [1.5351]	6600.0 [1.5468]
		6600.0 [1.5468]	6650.0 [1.5585]
		6650.0 [1.5585]	6700.0 [1.5702]
		6700.0 [1.5702]	6750.0 [1.5819]
		6750.0 [1.5819]	6800.0 [1.5936]
		6800.0 [1.5936]	6850.0 [1.6053]
		6850.0 [1.6053]	6900.0 [1.6170]
		6900.0 [1.6170]	6950.0 [1.6287]
		6950.0 [1.6287]	7000.0 [1.6404]
		7000.0 [1.6404]	7050.0 [1.6521]
		7050.0 [1.6521]	7100.0 [1.6638]
		7100.0 [1.6638]	7150.0 [1.6755]
		7150.0 [1.6755]	7200.0 [1.6872]
		7200.0 [1.6872]	7250.0 [1.6989]
		7250.0 [1.6989]	7300.0 [1.7106]
		7300.0 [1.7106]	7350.0 [1.7223]
		7350.0 [1.7223]	7400.0 [1.7340]
		7400.0 [1.7340]	7450.0 [1.7457]
		7450.0 [1.7457]	7500.0 [1.7574]
		7500.0 [1.7574]	7550.0 [1.7691]
		7550.0 [1.7691]	7600.0 [1.7808]
		7600.0 [1.7808]	7650.0 [1.7925]
		7650.0 [1.7925]	7700.0 [1.8042]
		7700.0 [1.8042]	7750.0 [1.8159]
		7750.0 [1.8159]	7800.0 [1.8276]
		7800.0 [1.8276]	7850.0 [1.8393]
		7850.0 [1.8393]	7900.0 [1.8510]
		7900.0 [1.8510]	7950.0 [1.8627]
		7950.0 [1.8627]	8000.0 [1.8744]
		8000.0 [1.8744]	8050.0 [1.8861]
		8050.0 [1.8861]	8100.0 [1.8978]
		8100.0 [1.8978]	8150.0 [1.9095]
		8150.0 [1.9095]	8200.0 [1.9212]
		8200.0 [1.9212]	8250.0 [1.932

ELECTRICAL DATA – RHPXYC SERIES						
		RHPXYC036ACT	RHPXYC036ADT	RHPXYC036AJT	RHPXYC048ACT	RHPXYC048ADT
Unit Information	Unit Operating Voltage Range	187-253	414-506	187-253	187-253	414-506
	Volts	208/230	460	208/230	208/230	460
	Phase	3	3	1	3	3
	Hz	60	60	60	60	60
	Minimum Circuit Ampacity	17	9	24	21	11
	Minimum Overcurrent Protection Device Size	20	15	30	25	15
	Maximum Overcurrent Protection Device Size	20	15	35	30	15
Compressor Motor	No.	1	1	1	1	1
	Volts	208/230	460	208/230	208/230	460
	Phase	3	3	1	3	3
	Amps (RLA), Comp. 1	8.6	4	14.6	10.8	5.9
	Amps (LRA), Comp. 1	70	39	76	123	60
	Amps (RLA), Comp. 2	N/A	N/A	N/A	N/A	N/A
	Amps (LRA), Comp. 2	N/A	N/A	N/A	N/A	N/A
Condenser Motor	No.	1	1	1	1	1
	Volts	208/230	460	208/230	208/230	460
	Phase	1	1	1	1	1
	HP	1/3	1/3	1/3	1/3	1/3
	Amps (FLA, each)	1.5	0.8	1.5	1.5	0.8
	Amps (LRA, each)	3	1.6	3	3	1.6
Evaporator Fan	No.	1	1	1	1	1
	Volts	208/230	460	208/230	208/230	460
	Phase	1	1	1	1	1
	HP	1/2	1/2	1/2	3/4	3/4
	Amps (FLA, each)	4.1	2.7	4.1	6	2.7
	Amps (LRA, each)	0	0	0	0	0

ELECTRICAL DATA – RHPXYC SERIES					
		RHPXYC048AJT	RHPXYC060ACT	RHPXYC060ADT	RHPXYC060AJT
Unit Information	Unit Operating Voltage Range	187-253	187-253	414-506	187-253
	Volts	208/230	208/230	460	208/230
	Phase	1	3	3	1
	Hz	60	60	60	60
	Minimum Circuit Ampacity	35	29	14	43
	Minimum Overcurrent Protection Device Size	40	35	20	50
	Maximum Overcurrent Protection Device Size	50	40	20	60
Compressor Motor	No.	1	1	1	1
	Volts	208/230	208/230	460	208/230
	Phase	1	3	3	1
	Amps (RLA), Comp. 1	21.5	12.4	6.5	23.7
	Amps (LRA), Comp. 1	102	93	60	123
	Amps (RLA), Comp. 2	N/A	N/A	N/A	N/A
	Amps (LRA), Comp. 2	N/A	N/A	N/A	N/A
Condenser Motor	No.	1	1	1	1
	Volts	208/230	208/230	460	208/230
	Phase	1	1	1	1
	HP	1/3	1/2	1/2	1/2
	Amps (FLA, each)	1.5	5.3	2.3	5.3
	Amps (LRA, each)	3			
Evaporator Fan	No.	1	1	1	1
	Volts	208/230	208/230	460	208/230
	Phase	1	1	1	1
	HP	3/4	1	1	1
	Amps (FLA, each)	6	7.6	3.5	7.6
	Amps (LRA, each)	0	0	0	0

Electric Heater Kit Factory Installed Options*	Unit Model Application
RXQJ-A10J (208-240 volt, 1-ph, 10kW)	RHPXYC036
RXQJ-A15J (208-240 volt, 1-ph, 15kW)	RHPXYC036
RXQJ-B15J (208-240 volt, 1-ph, 15kW)	RHPXYC048/060
RXQJ-A10C (208-240 volt, 3-ph, 10kW)	RHPXYC0036
RXQJ-A15C (208-240 volt, 3-ph, 15kW)	RHPXYC036/048/060
RXQJ-A10D (460 volt, 3-ph, 10kW)	RHPXYC036
RXQJ-A15D (460 volt, 3-ph, 15kW)	RHPXYC036/048/060

*Further kits for field installation on following pages.

WARNING

ONLY ELECTRIC HEATER KITS SUPPLIED BY THIS MANUFACTURER AS DESCRIBED IN THIS PUBLICATION HAVE BEEN DESIGNED, TESTED, AND EVALUATED BY A NATIONALLY RECOGNIZED SAFETY TESTING AGENCY FOR USE WITH THIS UNIT. USE OF ANY OTHER MANUFACTURED ELECTRIC HEATERS INSTALLED WITHIN THIS UNIT MAY CAUSE HAZARDOUS CONDITIONS RESULTING IN PROPERTY DAMAGE, FIRE, BODILY INJURY OR DEATH.

208/230 VOLT, THREE PHASE, 60 Hz, AUXILIARY ELECTRIC HEATER KIT CHARACTERISTICS AND APPLICATION

		Single Power Supply For Both Unit and Heater Kit				Separate Power Supply for Both Unit and Heater Kit					
Unit Model Number RHPXYC	Heater Kit			Air Conditioner			Heater Kit			Air Conditioner	
	Model No. RXQJ-	Rated Heater KW @ 208/230V	FLA	Unit Min. Ckt. Ampacity	Max Fuse or Ckt. Bkr. Size	Heater Kit Min. Ckt. Ampacity	Heater Kit Max Fuse or Ckt. Bkr. Size	Air Cond. Min. Ckt. Ampacity	Air Cond. Max. Fuse or Ckt. Bkr. Size		
RHPXYC036ACT	NONE	—	—	17/17	20/20	—	—	17/17	20/20		
	A05C	3.8/5	10.4/12	30/32	35/35	13/15	15/15	17/17	20/20		
	A08C	5.7/7.6	15.9/18.3	37/40	40/40	20/23	20/25	17/17	20/20		
	A10C	7.2/9.6	20/23.1	42/46	45/50	25/29	25/30	17/17	20/20		
	A15C	10.8/14.4	30.1/34.7	54/60	60/60	38/44	40/45	17/17	20/20		
RHPXYC048ACT	NONE	—	—	21/21	30/30	—	—	21/21	30/30		
	A05C	3.8/5	10.4/12	34/36	40/40	13/15	15/15	21/21	30/30		
	A08C	5.7/7.6	15.9/18.3	41/44	45/50	20/23	20/25	21/21	30/30		
	A10C	7.2/9.6	20/23.1	46/50	50/50	25/29	25/30	21/21	30/30		
	A15C	10.8/14.4	30.1/34.7	59/65	60/70	38/44	40/45	21/21	30/30		
RHPXYC060ACT	NONE	—	—	29/29	40/40	—	—	29/29	40/40		
	A05C	3.8/5	10.4/12	42/44	50/50	13/15	15/15	29/29	40/40		
	A08C	5.7/7.6	15.9/18.3	49/52	50/60	20/23	20/25	29/29	40/40		
	A10C	7.2/9.6	20/23.1	54/58	60/60	25/29	25/30	29/29	40/40		
	A15C	10.8/14.4	30.1/34.7	66/72	70/80	38/44	40/45	29/29	40/40		

460 VOLT, THREE PHASE, 60 Hz, AUXILIARY ELECTRIC HEATER KIT CHARACTERISTICS AND APPLICATION

		Single Power Supply For Both Unit and Heater Kit				Separate Power Supply for Both Unit and Heater Kit			
Unit Model Number RHPXYC	Heater Kit		Air Conditioner		Heater Kit		Air Conditioner		
	Model No. RXQJ-	Rated Heater KW @ 460V	FLA	Unit Min. Ckt. Ampacity	Max Fuse or Ckt. Bkr. Size	Heater Kit Min. Ckt. Ampacity	Heater Kit Max Fuse or Ckt. Bkr. Size	Air Cond. Min. Ckt. Ampacity	Air Cond. Max. Fuse or Ckt. Bkr. Size
RHPXYC036ADT	NONE	—	—	9	15	—	—	9	15
	A05D	4.8	5.8	16	20	8	15	9	15
	A08D	7.6	9.1	20	20	12	15	9	15
	A10D	9.6	11.6	24	25	15	15	9	15
	A15D	14.4	17.3	31	35	22	25	9	15
RHPXYC048ADT	NONE	—	—	11	15	—	—	11	15
	A05D	4.8	5.8	19	20	8	15	11	15
	A08D	7.6	9.1	23	25	12	15	11	15
	A10D	9.6	11.6	26	30	15	15	11	15
	A15D	14.4	17.3	33	35	22	25	11	15
RHPXYC060ADT	NONE	—	—	14	20	—	—	14	20
	A05D	4.8	5.8	22	25	8	15	14	20
	A08D	7.6	9.1	26	30	12	15	14	20
	A10D	9.6	11.6	29	30	15	15	14	20
	A15D	14.4	17.3	36	40	22	25	14	20

208/230V SINGLE PHASE, 60 Hz, AUXILIARY ELECTRIC HEATER KIT CHARACTERISTICS AND APPLICATION													
Single Power Supply For Both Unit and Heater Kit						Separate Power Supply for Both Unit and Heater Kit							
Unit Model Number RHPXYC	Heater Kit			Air Conditioner			Heater Kit			Air Conditioner			
	Model No. RXJJ-	Rated Heater KW @ 208/230V	FLA	Unit Min. Ckt. Ampacity	Max Fuse or Ckt. Bkr. Size	Heater Kit Min. Ckt. Ampacity	Heater Kit Max Fuse or Ckt. Bkr. Size	Air Cond. Min. Ckt. Ampacity	Air Cond. Max. Fuse or Ckt. Bkr. Size	Heater Kit Min. Ckt. Ampacity	Heater Kit Max Fuse or Ckt. Bkr. Size	Air Cond. Min. Ckt. Ampacity	Air Cond. Max. Fuse or Ckt. Bkr. Size
RHPXYC036AJT	NONE	—	—	24/24	35/35	—	—	24/24	35/35	—	—	24/24	35/35
	A05J	3.6/4.8	17.3/20	46/49	50/50	22/25	25/25	24/24	50/50	25/25	24/24	24/24	35/35
	A08J	5.7/7.6	27.4/31.6	59/64	60/70	35/40	35/40	24/24	60/70	35/40	24/24	24/24	35/35
	A10J	7.2/9.6	34.6/40	68/74	70/80	44/50	45/50	24/24	70/80	45/50	24/24	24/24	35/35
	A15J	10.8/14.4	51.9/60	89/99	90/100	65/75	70/80	24/24	90/100	65/75	70/80	24/24	35/35
RHPXYC048AJT	NONE	—	—	35/35	50/50	—	—	35/35	50/50	—	—	35/35	50/50
	A05J	3.6/4.8	17.3/20	56/60	70/70	22/25	25/25	35/35	70/70	25/25	35/35	35/35	50/50
	A08J	5.7/7.6	27.4/31.6	69/74	80/80	35/40	35/40	35/35	80/80	35/40	35/35	35/35	50/50
	B10J	7.2/9.6	34.6/40	78/85	90/90	44/50	45/50	35/35	90/90	45/50	35/35	35/35	50/50
	B15J	10.8/14.4	51.9/60	100/110	100/110	65/75	70/80	35/35	100/110	65/75	70/80	35/35	50/50
RHPXYC060AJT	NONE	—	—	43/43	60/60	—	—	43/43	60/60	—	—	43/43	60/60
	A05J	3.6/4.8	17.3/20	65/68	80/80	22/25	25/25	43/43	80/80	25/25	43/43	43/43	60/60
	A08J	5.7/7.6	27.4/31.6	77/83	90/90	35/40	35/40	43/43	90/90	35/40	43/43	43/43	60/60
	B10J	7.2/9.6	34.6/40	86/93	100/100	44/50	45/50	43/43	100/100	45/50	43/43	43/43	60/60
	B15J	10.8/14.4	51.9/60	108/118	110/125	65/75	70/80	43/43	110/125	65/75	70/80	43/43	60/60

ACCESSORY EQUIPMENT

Accessory Description	Accessory Model No.
Roofcurb	RXSG-AXA14 (14" [356 mm] Height)
	RXSG-AXA24 (24" [610 mm] Height)
Curb Adapter ("A" footprint to "X" footprint)	RXRX-DXCAE
Duct Adapter Sideflow Square to Round Transition	AXMC-BA01
Supply & Return Diffusers	RXRN-BD15
Rectangular to Round Transition (Downflow)	RXMC-CA02 (16" [406 mm] Ducts)
	RXMC-CA03 (18" [457 mm] Ducts)
Economizers (Convertible)	RXRE-11RXCAM3
Dual Enthalpy Kit	PD555460
Fresh Air Damper	RXRF-FAA2 (Fixed-35%)
	RXRF-FAB2 (Motorized-35%)
Filter Kit	RXRY-B02
Split Door Design Kit	RXRX-SDX01
Low Ambient Control	RXPZ-G01
Phase Monitor Kit	RXRX-PM3A01

[] Designates Metric Conversions

COMMON SUPPLY/RETURN CONCENTRIC AIR DIFFUSER

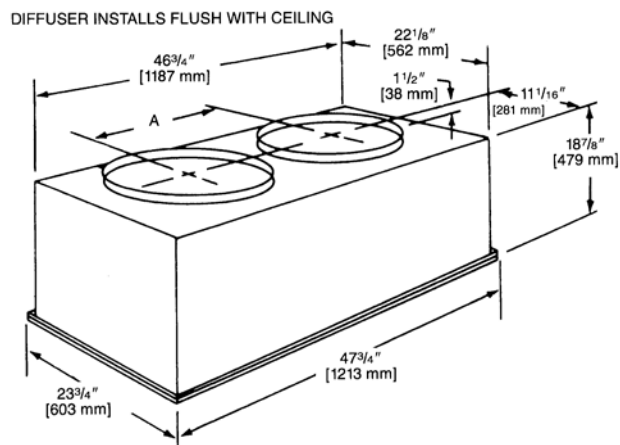
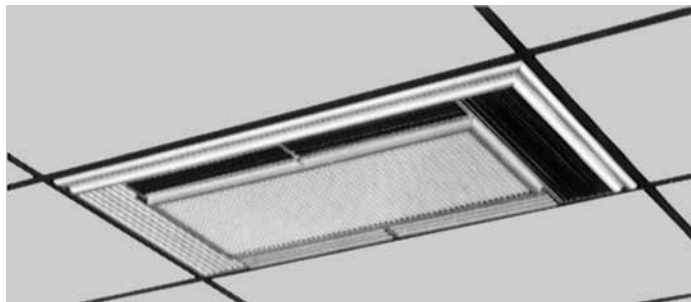

SUPPLY/RETURN DIFFUSER

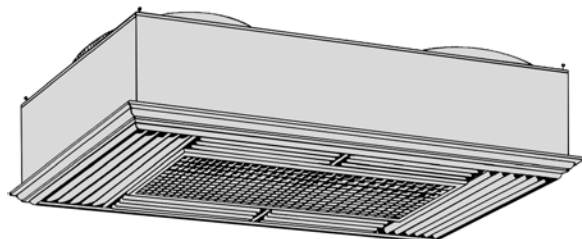

Designed to convert a side by side or an over and under arrangement into a concentric distribution of air. The diffuser is flush mounted, completely insulated, assembled, and internally baffled to provide four way supply air distribution with a center return. To make the assembly complete and ready to fit into a 2' [0.61 m] x 4' [1.22 m] suspended ceiling grid, the diffuser includes adjustable supply louvers, hanging rings, anti-sweat gasket, and round flanges for use with flexible ducts.

Model No. RXRN-	Diameter Inches [mm]	Shipping Wt. Lbs. [kg]	Dimension A Inches [mm]
BD15	16 [406]	90 [40.82]	20 1/2 [521]

[] Designates Metric Conversions

NOTE: The location of the combination supply and return diffuser should not exceed 10 feet [3.05 m] above the floor level for units @ 1000 CFM [472 L/s] or less and 12 [3.66 m] to 14 feet [4.27 m] above the floor level for units with CFM greater than 1000 [472 L/s]. If the diffuser is installed with a greater distance than recommended above, the supply air may become stratified above the required comfort area causing uncomfortable conditions.

AIRFLOW/PRESSURE DROP INFORMATION (INCHES W.C. [kPa])

Accessory	Approximate CFM [L/s]-Supply Air			
	1300 [614]	1575 [743]	1800 [850]	2200 [1038]
Plenum & Supply/Return Duct	.07 [.017]	.10 [.024]	.12 [.030]	.17 [.042]
Diffuser	.09 [.022]	.13 [.032]	.16 [.040]	.24 [.060]
Economizer	.06 [.015]	.09 [.022]	.11 [.027]	.17 [.042]

SUPPLY AIR/PERFORMANCE

Difuser Airflow CFM [L/s]	Range of Throw Ft.
800 [378]-1200 [566]	14 [4.27]-16 [4.88]
1600 [755]-2000 [944]	18 [5.49]-28 [8.53]

DUCT ADAPTERS RECTANGULAR TO ROUND TRANSITIONS (DOWNFLOW)

RXMC-CA02

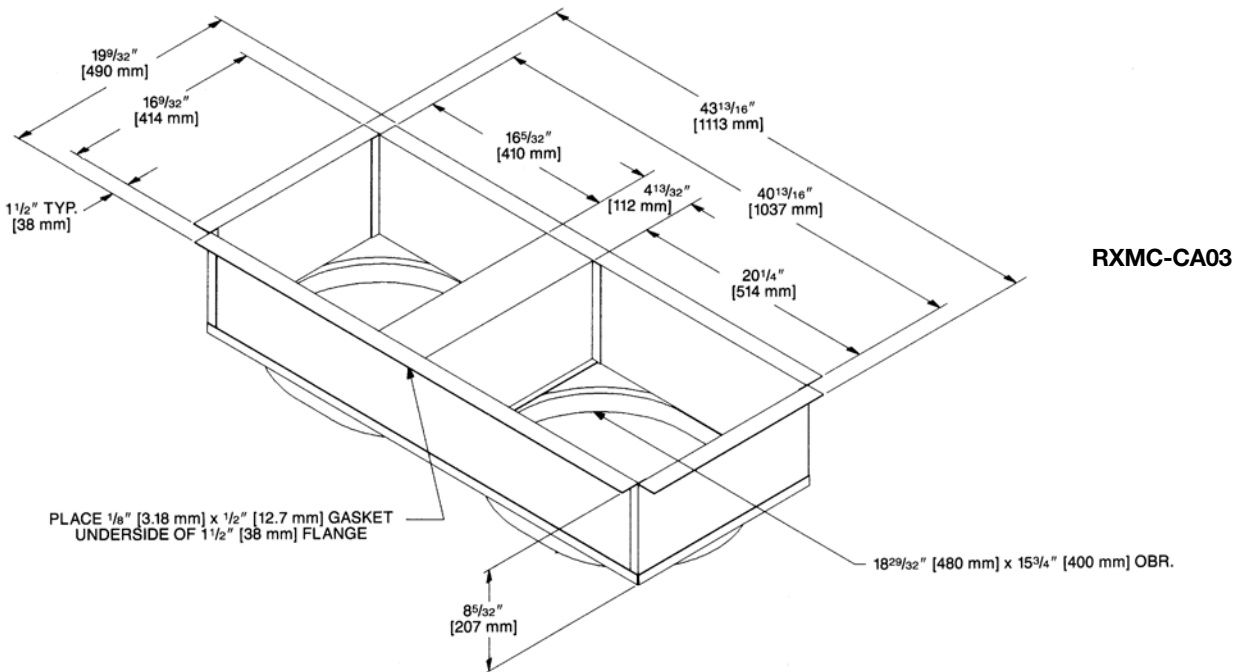
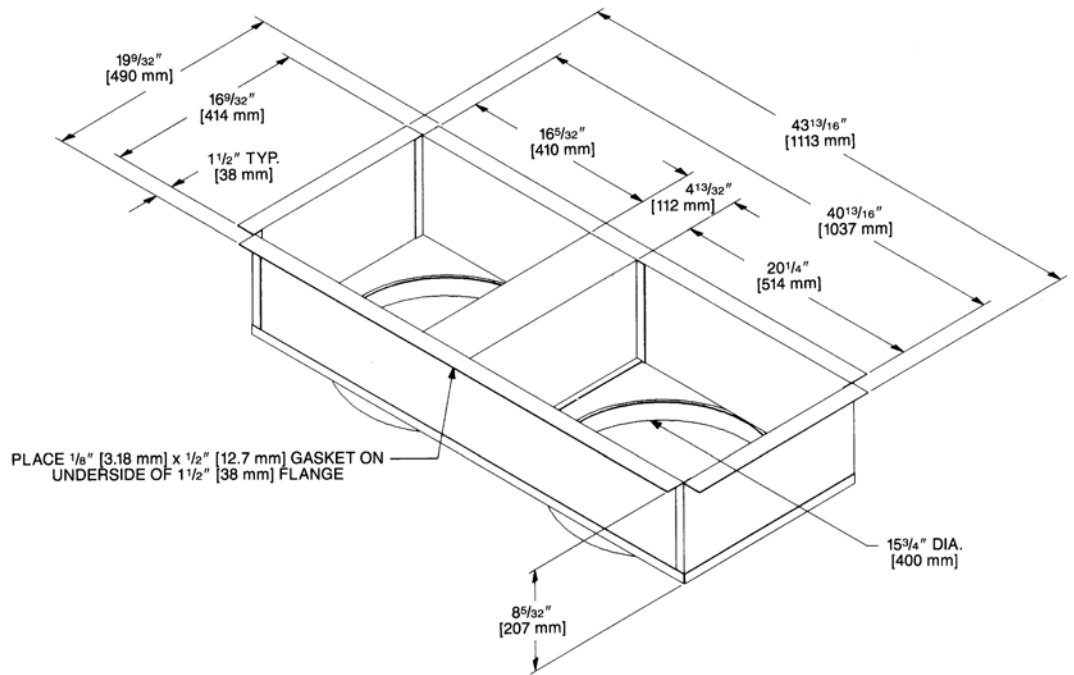

[] Designates Metric Conversions

DUCT ADAPTER SIDEFLOW SQUARE TO ROUND TRANSITION AXMC-BA01

Adapts the side rectangular supply and return openings to 14" [356 mm] diameter round openings. Adapters provided with same finish as unit and also provided with thermal insulation.

[] Designates Metric Conversions

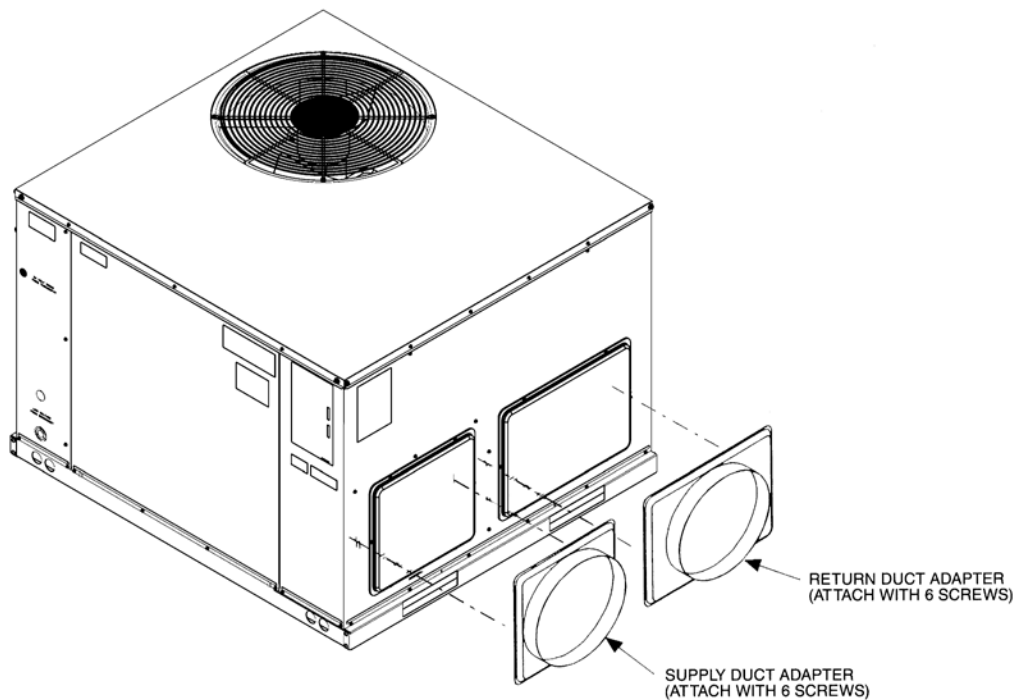

ROOFCURB (Full Perimeter) RXSG-AXA14 & RXSG-AXA24

Note: Hinged corners make
for fast, easy set-up

RXSG-AXA14
(14" [356 mm] Height)

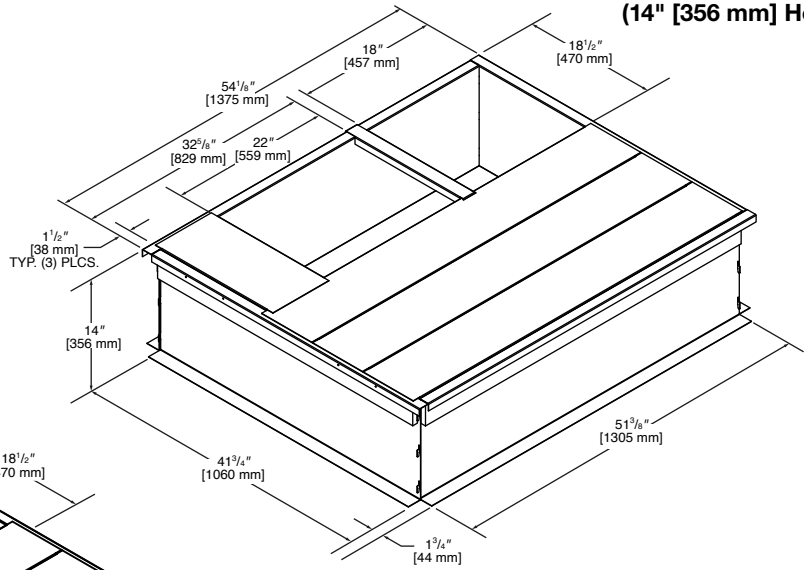

RXSG-AXA24
(24" [610 mm] Height)

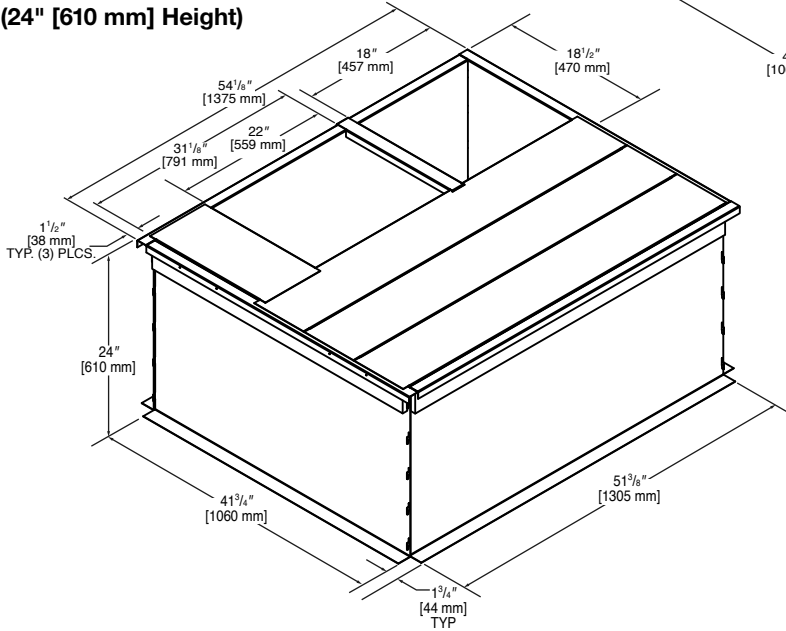

PACKAGED HEAT PUMP ROOFCURB INSTALLATION (Full Perimeter)

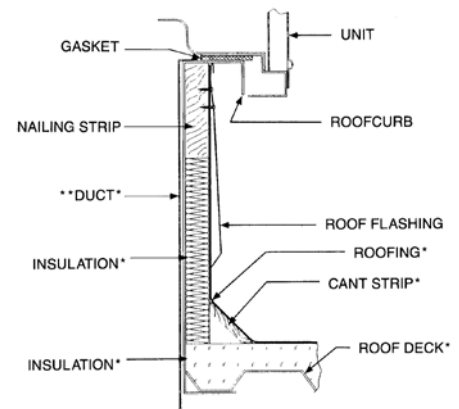
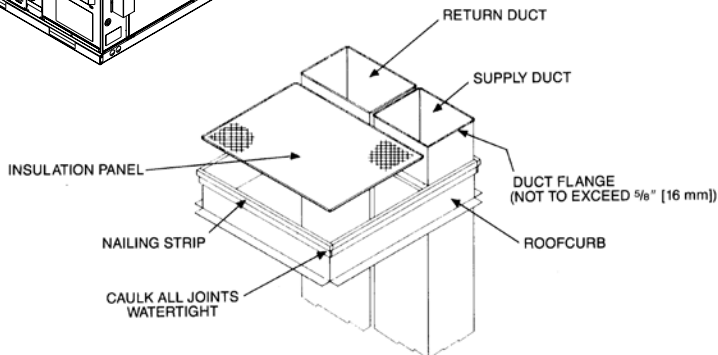
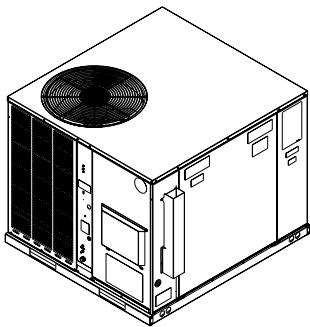

*BY CONTRACTOR
**FOR INSTALLATION OF DUCT AS SHOWN, USE RECOMMENDED DUCT SIZES FROM ROOFCURB INSTALLATION INSTRUCTIONS. FOR DUCT FLANGE AT TACHMENT TO UNIT, SEE UNIT INSTALLATION INSTRUCTIONS FOR RECOMMENDED DUCT SIZES.

[] Designates Metric Conversions

ROOFCURB ADAPTERS

Fabricated from galvanized steel to adapt the New cabinet to the old style curb. All are furnished with a New gasket.

OLD MODEL PACKAGE HEAT PUMP

SMALL CABINET
(1½-2 TON) [5.28-7.03 kW]
RPNC-
RPND-

MEDIUM CABINET
(2½-3 TON) [8.79-10.55 kW]
RPNC-
RPND-

EXTRA LARGE CABINET
(3½-5 TON) [12.31-17.58 kW]
RPNC-
RPND-

OLD CURB MODEL



RXPA-CA20



RXPA-CA21



RXPA-CA23

“A” CABINET TO OLD MODEL ROOFCURB ADAPTER

RXPX-BACCA20
RXPX-BACCA21
RXPX-BCCCA23

“A” CABINET PACKAGE HEAT PUMP

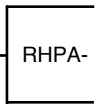

“A” CABINET TO “X” CABINET ADAPTER

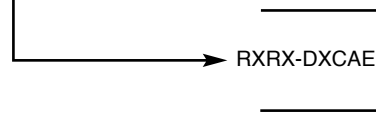

“X” CABINET PACKAGE HEAT PUMP

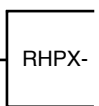

[] Designates Metric Conversions

FRESH AIR DAMPER

RXRF-FAA2 (Fixed – 0-35%)

The 0-35% manual outside Air Damper is designed to replace the unit return air duct cover. No drilling or damper assembly is required. The amount of outside air (0-35%) is controlled by simply adjusting the side damper.

RXRF-FAB2 (Motorized – 0-35%)

The 0-35% manual outside Air Damper is designed to replace the unit return air duct cover. No drilling or damper assembly is required. The amount of outside air (0-35%) is controlled by simply adjusting the side damper.

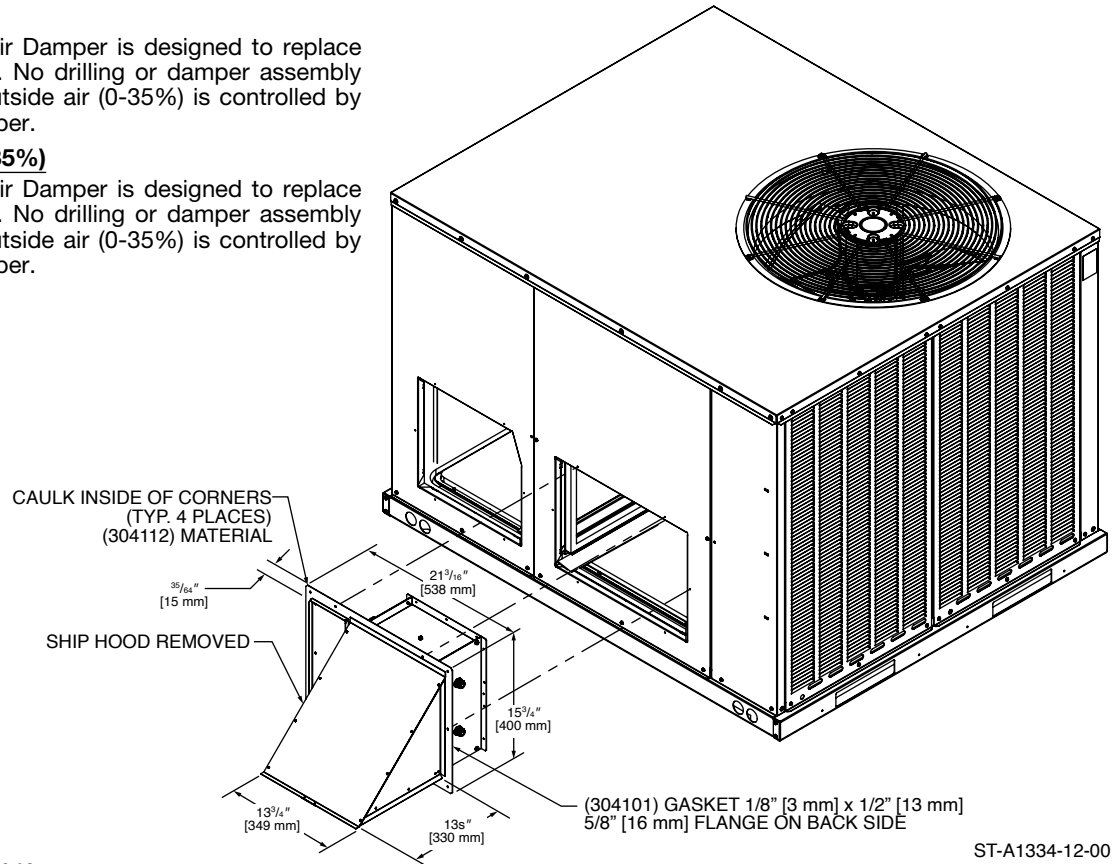

[] Designates Metric Conversions

ST-A1334-12-00

ECONOMIZER RXRE-11RXCAM3

- LCD Screen for Continuous diagnostic and system status
- Programmable set points for accurate positioning
- Simplified wiring and color coded terminals
- Onboard fault detection and diagnostics (FDD)
- Operational Checkout to verify installation
- Enthalpy sensors and actuator that communicate with Siemens controller reducing wiring errors while providing more information
- Setup and configure the economizer controller before putting it into usage by using the Climatix Mobile app or the inbuilt display
- CO2 sensor input for demand control ventilation (DCV) applications
- RXRX-BV03 dual enthalpy kit available for field installation
- AMCA licensed class 1A low leak dampers

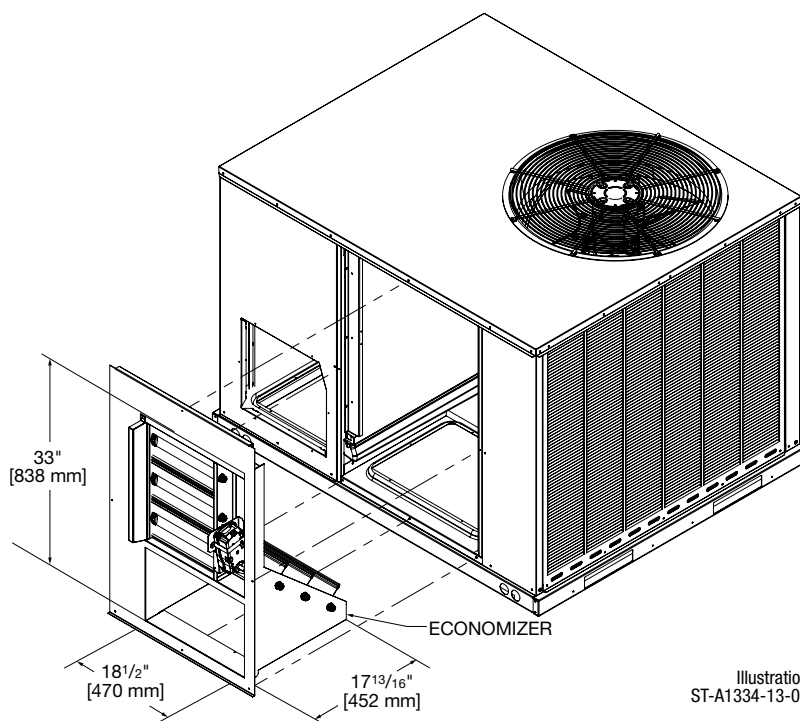

Illustration
ST-A1334-13-00

VERTICAL APPLICATION

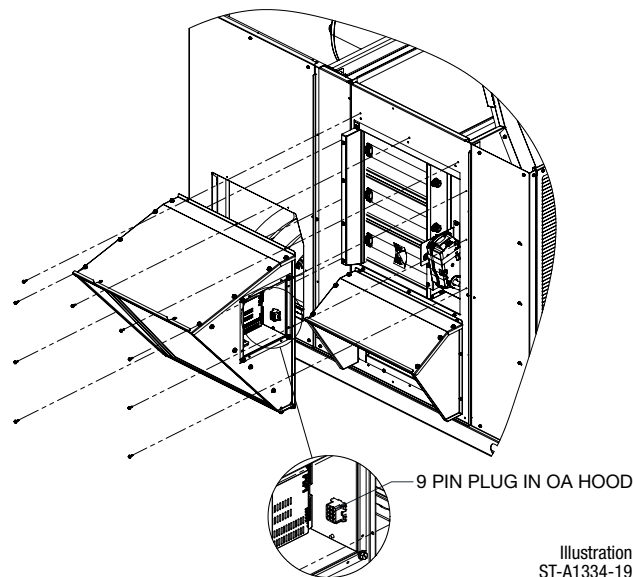
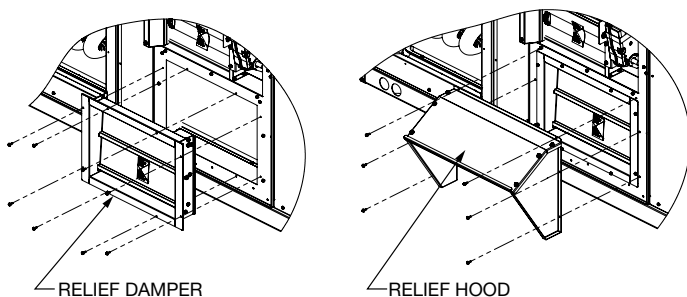

Illustration
ST-A1334-19

HORIZONTAL APPLICATION

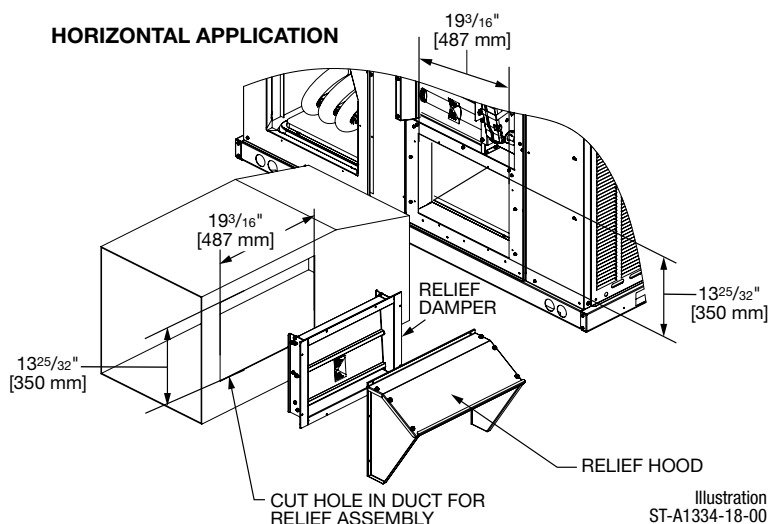

Illustration
ST-A1334-18-00

[] Designates Metric Conversions

FILTER KIT INSTALLATION RXRY-B02

For use in either vertical or horizontal discharge

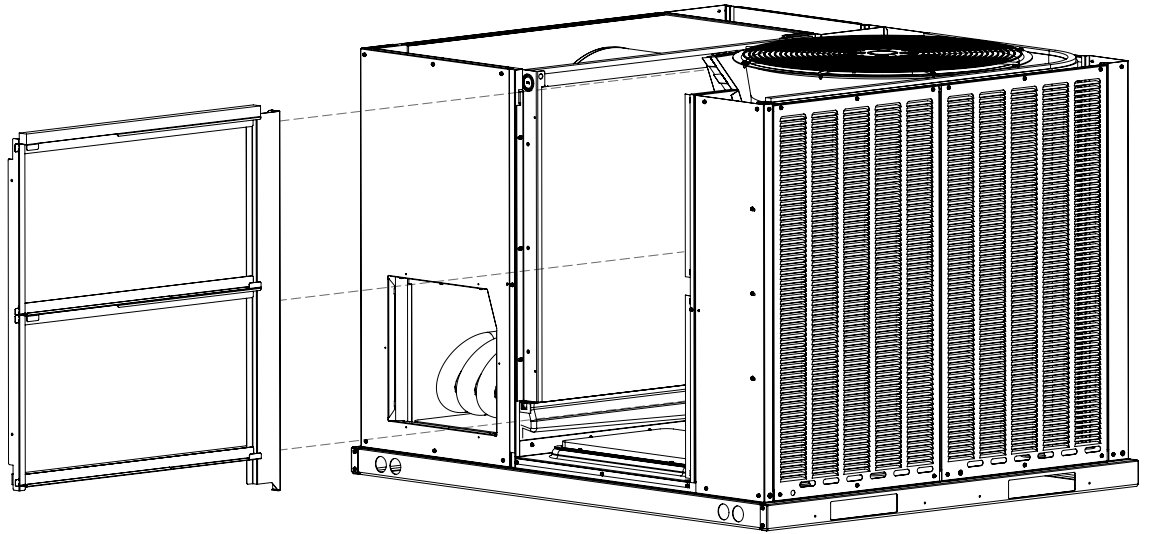

Illustration
ST-A1352-01-00

Airflow Pressure Drop (1" filter)	
CFM [L/s]	Inches W.C. [kPa]
600 [283]	0.01 [0.002]
800 [378]	0.01 [0.002]
1000 [472]	0.02 [0.005]
1200 [566]	0.03 [0.008]
1400 [661]	0.05 [0.012]
1600 [755]	0.07 [0.017]
1800 [850]	0.08 [0.021]
2000 [944]	0.10 [0.026]

[] Designates Metric Conversions



GENERAL TERMS OF LIMITED WARRANTY*

Russell® By Rheem will furnish a replacement for any part of this product which fails in normal use and service within the applicable periods stated, in accordance with the terms of the limited warranty.

***For complete details of the Limited and Conditional Warranties, including applicable terms and conditions, contact your local contractor or the Manufacturer for a copy of the product warranty certificate.**

Compressor

1 Phase, Residential Applications Ten (10) Years
1 & 3 Phase, Commercial Applications Five (5) Years

Parts

Residential Applications
(Registration Required) Ten (10) Years
Commercial Applications..... One (1) Year

© 2024 Rheem Manufacturing Company. Russell By Rheem trademarks owned by Rheem Manufacturing Company.

In keeping with its policy of continuous progress and product improvement, Russell by Rheem reserves the right to make changes without notice.



Russell® By Rheem

5600 Old Greenwood Road, Fort Smith, AR 72908

Before proceeding with installation, refer to installation instructions packaged with each model, as well as complying with all Federal, State, Provincial, and Local codes, regulations, and practices.

PRINTED IN U.S.A. 10/24 QG FORM NO. PRR-856