



RELY ON RUUD.™

# SUBMITTAL COVER SHEET

PROJECT NAME \_\_\_\_\_

LOCATION \_\_\_\_\_

ARCHITECT \_\_\_\_\_

ENGINEER \_\_\_\_\_

CONTRACTOR \_\_\_\_\_

SUBMITTED BY \_\_\_\_\_ DATE \_\_\_\_\_

## UNIT SUMMARY

Quantity						
Unit Designation						
Model No.						
Total Cooling						
Sensible Cooling						
Air Ent. Evaporator						
Air Lvg. Evaporator						
Heating Input						
Heating Output						
CFM/ESP						
EER/SEER						
Electrical						
Minimum Ampacity						
Min.-Max. Breaker						
Net Unit Weight						
Accessory						
Catalog Form Number						

**ACCESSORIES:**

**NOTES:**

# SUBMITTAL SHEET FOR (-)P17 SERIES ECONET ENABLED HEAT PUMPS 2, 3, 4 AND 5 NOMINAL TON [7.03, 10.6, 14.06 AND 17.6 kW] UP TO 18.5 SEER/13 EER

JOB NAME \_\_\_\_\_ LOCATION \_\_\_\_\_  
 CONTRACTOR \_\_\_\_\_ ORDER NO. \_\_\_\_\_  
 ENGINEER \_\_\_\_\_ UNIT MODEL NO. \_\_\_\_\_  
 SUBMITTED FOR  APPROVAL  RECORD COIL MODEL NO. \_\_\_\_\_  
 DATE \_\_\_\_\_ AIR HANDLER MODEL NO. \_\_\_\_\_

## UNIT DATA

### COOLING PERFORMANCE

EFFICIENCY ..... SEER  
 TOTAL CAPACITY\* ..... MBH [kW]  
 SENSIBLE CAPACITY\* ..... MBH [kW]  
 OUTDOOR DESIGN TEMP. .... °F [°C] DB  
 TEMP. OF AIR ENTERING  
 EVAPORATOR COIL ..... °F [°C] DB  
 ..... °F [°C] WB  
 POWER INPUT REQUIREMENT ..... kW  
 (\*uses blower motor heat)

### HEATING PERFORMANCE

EFFICIENCY ..... HSPF  
 TOTAL CAPACITY\* ..... MBH [kW]  
 OUTDOOR DESIGN TEMP. .... °F [°C] DB  
 TEMP. OF AIR ENTERING  
 EVAPORATOR COIL ..... °F [°C] DB

### SUPPLY AIR BLOWER PERFORMANCE

TOTAL AIR SUPPLY ..... CFM [L/s]  
 TOTAL RESISTANCE EXTERNAL  
 TO UNIT ..... IWG  
 BLOWER SPEED ..... RPM  
 POWER OUTPUT REQUIREMENT .... BHP  
 MOTOR RATING ..... HP [W]  
 POWER INPUT REQUIREMENT ..... kW

### ELECTRICAL DATA

POWER SUPPLY ..... Hz  
 TOTAL UNIT AMPACITY ..... AMPS  
 MINIMUM WIRE SIZE ..... AWG  
 MAXIMUM OVERCURRENT DEVICE  
 FUSES/HACR BREAKER ..... AMPS

### CLEARANCES

ACCESS SIDE 24" [609.6 mm]  
 AIR INLETS 12" [304.8 mm]  
 ABOVE UNIT 60" [1524 mm]

## FEATURES FOR (-)P17 SERIES HEAT PUMP UNITS

- **EcoNet® Enabled product.** The EcoNet Smart Home System provides advanced air & water control for maximum energy savings and ideal comfort.
- Copeland Scroll™ Variable Speed compressor. This inverter driven compressor provides three stages of heating and cooling operation for maximum comfort and energy savings. The overdrive feature in heating provides heating down to 7°F.
- Equipped with electronic expansion valve to precisely control variable refrigerant flow.
- New composite base pan – dampens sound, captures louver panels, eliminates corrosion and reduces number of fasteners needed
- Improved tubing design – reduces vibration and stress, making unit quieter and reducing opportunity for leaks
- Optimized defrost characteristics - decrease defrosting and provide better home comfort
- Optimized reversing valve sizing – improves shifting performance for quieter unit operation and increased life of the system
- Enhanced mufflers – help to dissipate vibration energy for quieter unit operation
- Modern cabinet aesthetics – increased curb appeal with visually appealing design
- Curved louver panels – provide ultimate coil protection, enhance cabinet strength, and increased cabinet rigidity
- Optimized fan orifice – optimizes airflow and reduces unit sound
- Rust resistant screws – confirmed through 1500-hour salt spray testing
- **PlusOne® Expanded Valve Space** – 3"-4"-5" service valve space – provides a minimum working area of 27-square inches for easier access
- Integrated heat pump lift receptacle – allows standard CPVC stands to be inserted into the base
- **PlusOne® Triple Service Access** – 15" wide, industry leading corner service access – makes repairs easier and faster. The two fastener removable corner allows optimal access to internal unit components. Individual louver panels come out once fastener is removed, for faster coil cleaning and easier cabinet reassembly
- Diagnostic service window with two-fastener opening – provides access to the TXV valves and the heat pump reversing valve before opening the unit.
- External gauge port access – allows easy connection of "low-loss" gauge ports
- Single-row condenser coil – makes unit lighter and allows thorough coil cleaning to maintain "out of the box" performance
- 35% fewer cabinet fasteners and fastener-free base – allow for faster access to internal components and hassle-free panel removal
- Service trays – hold fasteners or caps during service calls
- QR code – provides technical information on demand for faster service calls
- Fan motor harness with extra-long wires – allows unit top to be removed without disconnecting fan wire

## ACCESSORIES/OPTIONS

- EcoNet Smart Thermostat .....   
 WiFi Kit for Heating & Cooling .....   
 Heat Pump Riser 6 in. (686020) .....



(IN CERTAIN MATCHED SYSTEMS)

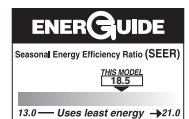

(-)P17, 24, 36, 48, 60

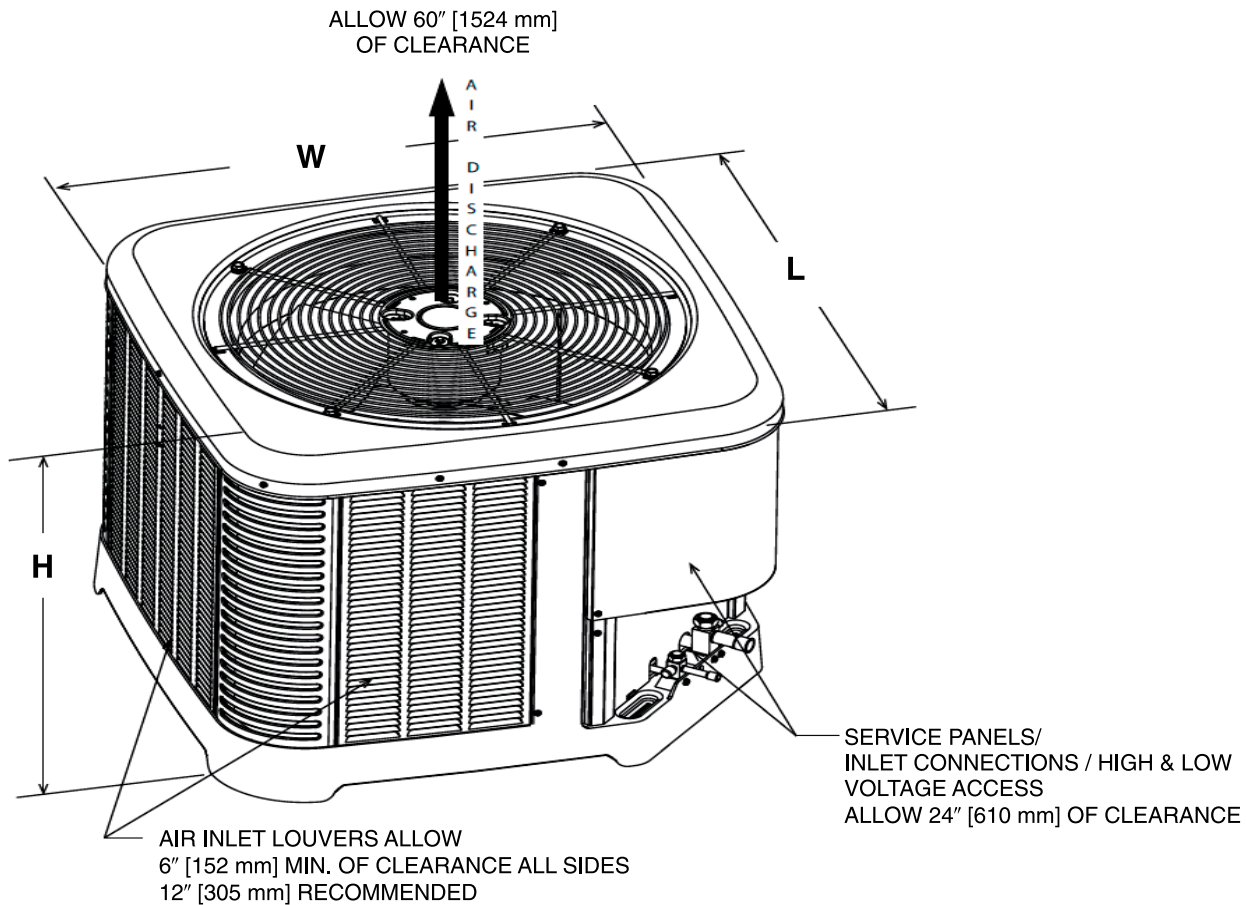

ST-A1226-02-00

## Unit Dimensions

MODEL NO.	OPERATING						SHIPPING					
	H (Height)		L (Length)		W (Width)		H (Height)		L (Length)		W (Width)	
	INCHES	mm	INCHES	mm	INCHES	mm	INCHES	mm	INCHES	mm	INCHES	mm
(-)P1724	35	889	33.75	857	33.75	857	35.75	908	36.38	924	36.38	924
(-)P1736	35	889	33.75	857	33.75	857	36.75	933	36.38	924	36.38	924
(-)P1748	39	990	35.75	908	35.75	908	40.75	1035	38.38	974	38.38	974
(-)P1760	45	1143	35.75	908	35.75	908	46.75	1187	38.38	974	38.38	974

[ ] Designates Metric Conversions

Before proceeding with installation, refer to installation instructions packaged with each model, as well as complying with all Federal, State, Provincial, and Local codes, regulations, and practices.

Rheem Sales Company, Inc.  
P.O. Box 17010, Fort Smith, AR 72917

"In keeping with its policy of continuous progress and product improvement, Rheem reserves the right to make changes without notice."