



Russell[™]
By Rheem

MODEL: RGEA16 Package Gas Electric Unit

FORM NO. RRR-871 REV. 1

Russell[™] By Rheem Package Gas Electric Unit



RGEA16

- Nominal Sizes 2-5 Tons [7.0-17.6 kW]
- Efficiencies up to 16 SEER/12.4 EER



TABLE OF CONTENTS

Unit Features & Benefits	3-4
Model Number Identification	5
Available SKUs	5
Options	6
General Data	
RGEA16 Series	7-14
General Data Notes	15
Gross Systems Performance Data	
RGEA16 Series	16-19
Indoor Airflow Performance	
RGEA16 Series	20-21
Electrical Data	
RGEA16 Series	22
Dimensional Data	23-24
Typical Installations	25
Accessories	26-33
Limited Warranty	34

Package Gas Electric Unit Features:

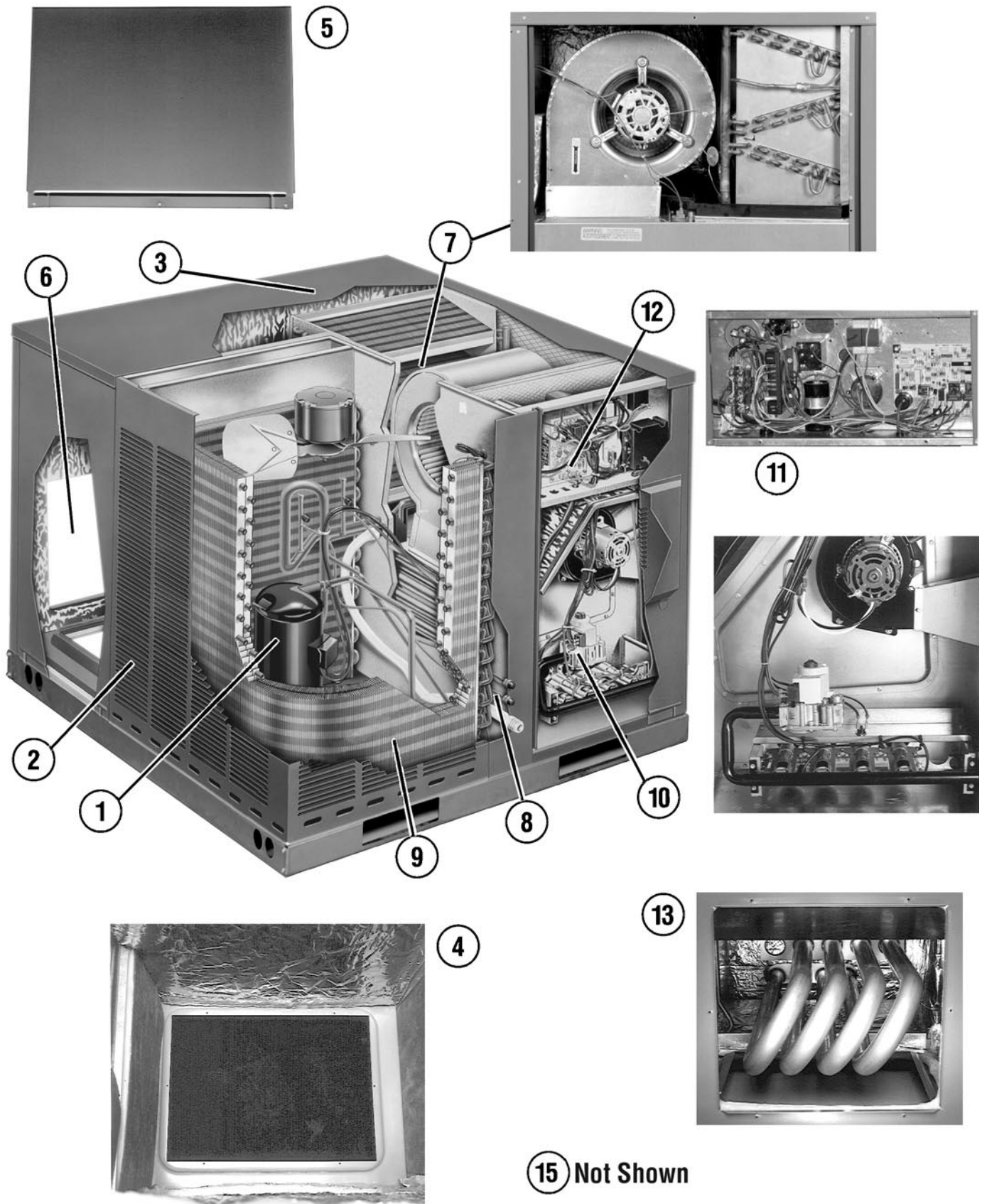



RGEA16 Features Below Correspond to Photos on Page 3

1. All models feature Scroll® compressors for maximum efficiency and quiet operation. All RGEA16 models feature UltraTech™ Scroll 2-Stage compressors with Comfort Alert™ diagnostics (see below), high/low pressure switches, and hard start kits.
2. Louvered condenser compartment for protecting the coil against yard hazards and/or weather extremes.
3. One-piece top with a deep flange to help keep water out of the unit.
4. Supply and return air openings feature a one-inch tall flange to prevent water migration into the ductwork.
5. Access panels have “weep holes” and channels to further help manage water run-off.
6. Side and down discharge options available on all models. All models are shipped ready for horizontal application.
7. Easily accessible blower section complete with slide-out blower. The RGEA16 comes standard with variable speed motor with adjustable airflow in heating and cooling. The variable speed motor also comes with a interface that allows for dehumidification when used with a humidistat or an on-demand dehumidification “ODD” capable thermostat. The variable speed system is capable of 1 inch external static.
8. Refrigerant connections are conveniently located for easy service diagnostics.
9. Condenser and evaporator coils feature enhanced fins for better heat transfer and rifled copper tubing for greater efficiency.
10. Inside the easily accessible furnace compartment is the draft inducer motor. This motor is specially designed for quiet reliable operation. In addition to the draft inducer motor, the in-shot gas burners and manifold efficiently regulate the flow of gas for combustion. These new gas/electric units also feature direct-spark ignition and remote flame sensors for added reliability and efficiency.
11. Easily accessible control box.
12. Single point wiring simplifies installation.
13. Our gas/electric package units feature a tubular heat exchanger design. Tubular heat exchangers are more efficient and durable than older-style clamshell heat exchangers. Stainless Steel Heat Exchanger is a standard feature on the RGEA16 and is backed by a limited lifetime warranty when installed in a residential application, and a 20 year warranty when installed in a commercial application. Two stage gas heat is standard on the RGEA16 models.
14. Thermal expansion valve standard on all models for superior superheat control, reliability, and energy efficiency at all operating conditions.
15. Filter drier standard on all models (not shown).
16. Rugged baserail included for improved installation and handling
17. Complete factory charged, wired and run tested.
18. Molded compressor plugs.

Comfort Alert™ Diagnostics – Faster Service And Improved Accuracy (2-Stage Models Only)

The Comfort Alert™ diagnostics module is a breakthrough innovation for troubleshooting air conditioning system failures. The module is installed in the control box near the compressor contactor. By monitoring and analyzing data from the Scroll® compressor and the thermostat demand, the module can accurately detect the cause of electrical and system related failures without any sensors. A flashing LED indicator communicates the ALERT code and guides the service technician more quickly and accurately to the root cause of a problem.

NOTE: Module provides compressor protection and will shut down the compressor when compressor damaging conditions are detected.

RGEA16 Models Also Feature:

- On Demand Dehumidification
- Variable speed motor with adjustable airflow in both heating and cooling to 1.0" SP static capability
- Stainless steel heat exchanger as standard
- Two stage gas heat

R GE A 16 036 A J V 10 2 A A X X X

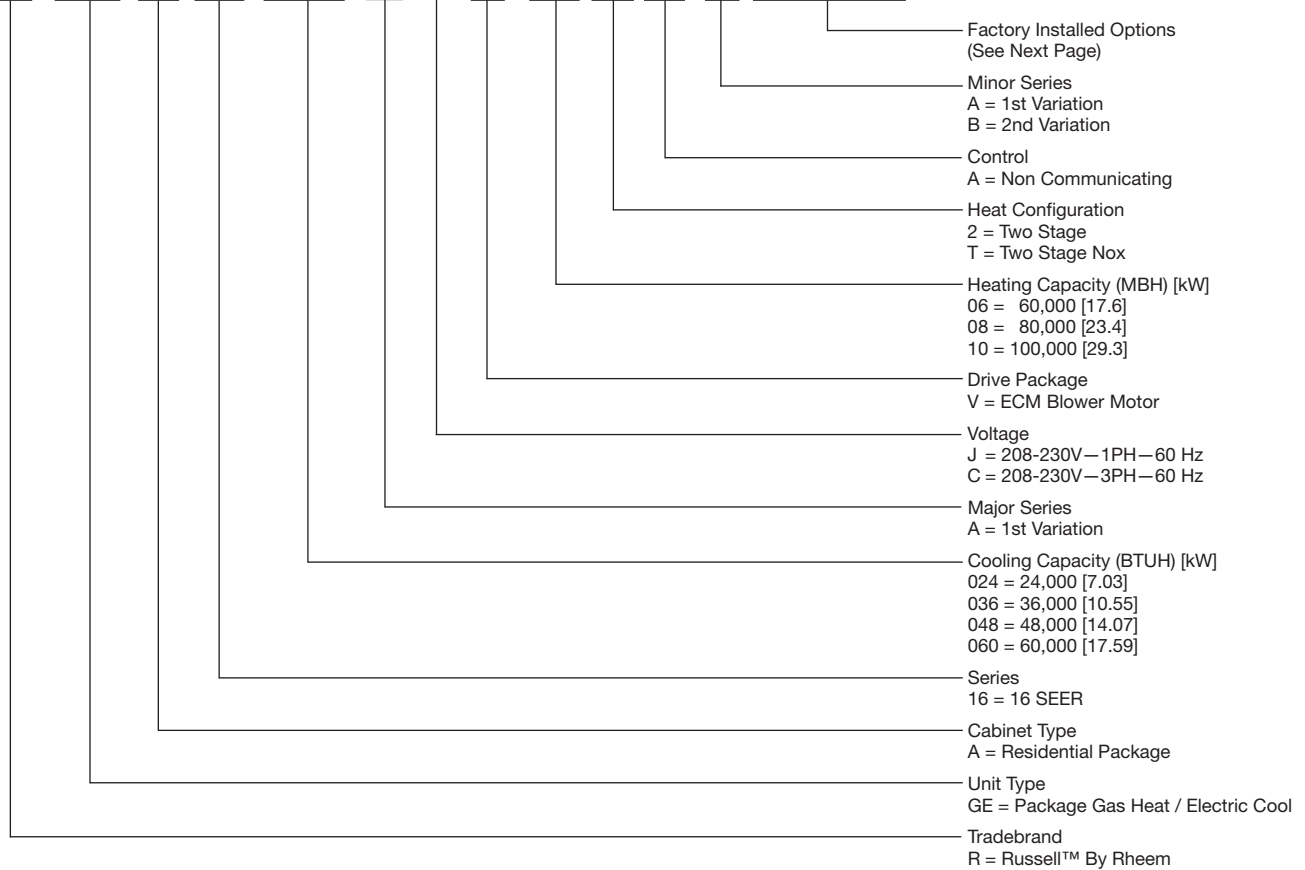

[] Designates Metric Conversions

AVAILABLE SKUs

Available Models		
RGEA16024AJV062AB	RGEA16036AJV06TAB	RGEA16048AJV082AB
RGEA16024AJV06TAB	RGEA16036AJV082AB	RGEA16048AJV08TAB
RGEA16036ACV062AA	RGEA16036AJV08TAB	RGEA16048AJV102AB
RGEA16036ACV06TAA	RGEA16036AJV102AB	RGEA16048AJV10TAB
RGEA16036ACV082AA	RGEA16036AJV10TAB	RGEA16060ACV102AA
RGEA16036ACV08TAA	RGEA16048ACV082AA	RGEA16060ACV10TAA
RGEA16036ACV102AA	RGEA16048ACV08TAA	RGEA16060AJV102AB
RGEA16036ACV10TAA	RGEA16048ACV102AA	RGEA16060AJV10TAB
RGEA16036AJV062AB	RGEA16048ACV10TAA	

Instructions for Factory Installed Option(s) Selection

Note: Two characters following the model number will be utilized to designate a factory-installed option or combination of options. If no factory option(s) is required, nothing follows the model number.

Step 1. After a basic rooftop model is selected, choose a *two-character* option code from the FACTORY INSTALLED OPTION SELECTION TABLE.

FACTORY INSTALLED OPTION CODES

Option Code	Stainless Steel Heat Exchanger	Tin Plated Hairpin Coil
AU		X

“X” indicates factory installed option.

Example: No Option

RGEA16024AJV062AA

Example: Option with Tinplated Hairpin Coil

RGEA16024AJV062AAAU

Note: Factory installed economizer is not available on these models.

*AU is the only option available for RGEA16 units because Stainless Steel Heat Exchanger is standard.

NOMINAL SIZES 2-5 TONS [7.0-17.6 kW]

Model RGEA16 Series	024AJV062AA	024AJV062AB	024AJV06TAA	024AJV06TAB
Cooling Performance¹				CONTINUED →
AHRI Net Cooling Capacity (2nd stage) Btu [kW]	23,000 [6.74]	23,000 [6.74]	23,000 [6.74]	23,000 [6.74]
SEER ²	15.5	15.5	15.5	15.5
EER (2nd stage)	11.9	11.9	11.9	11.9
AHRI Rated CFM (1st / 2nd stage) [L/s]	550/800 [260/378]	550/800 [260/378]	550/800 [260/378]	550/800 [260/378]
Net Sensible Capacity (2nd stage) Btu [kW]	16,820 [4.93]	16,820 [4.93]	16,820 [4.93]	16,820 [4.93]
Net Latent Capacity (2nd stage) Btu [kW]	6,180 [1.81]	6,180 [1.81]	6,180 [1.81]	6,180 [1.81]
Net System Power (1st / 2nd stage) kW	1.37/1.92	1.37/1.92	1.37/1.92	1.37/1.92
Heating Performance (Gas)³				
Heating Input Btu [kW] (1st Stage / 2nd Stage)	46,000/60,000 [13.48/17.58]	46,000/60,000 [13.48/17.58]	46,000/60,000 [13.48/17.58]	46,000/60,000 [13.48/17.58]
Heating Output Btu [kW] (1st Stage / 2nd Stage)	37,567/49,000 [11.01/14.36]	37,567/49,000 [11.01/14.36]	37,567/49,000 [11.01/14.36]	37,567/49,000 [11.01/14.36]
Temperature Rise Range °F [°C] (1st Stage / 2nd Stage)	10-40 [5.6-22.2] / 20-50 [11.1-27.8]	10-40 [5.6-22.2] / 20-50 [11.1-27.8]	10-40 [5.6-22.2] / 20-50 [11.1-27.8]	10-40 [5.6-22.2] / 20-50 [11.1-27.8]
AFUE % ⁴	81	81	81	81
Steady State Efficiency (%)	82	82	82	82
No. Burners	3	3	3	3
No. Stages	2	2	2	2
Gas Connection Pipe Size in. [mm]	0.5 [12.7]	0.5 [12.7]	0.5 [12.7]	0.5 [12.7]
Compressor				
No./Type	1/Scroll	1/Scroll	1/Scroll	1/Scroll
Outdoor Sound Rating (dB)⁵	76	76	76	76
Outdoor Coil—Fin Type	Louvered	Louvered	Louvered	Louvered
Tube Type	Rifled	Rifled	Rifled	Rifled
Tube Size in. [mm] OD	0.375 [9.5]	0.375 [9.5]	0.375 [9.5]	0.375 [9.5]
Face Area sq. ft. [sq. m]	10.56 [0.98]	10.56 [0.98]	10.56 [0.98]	10.56 [0.98]
Rows / FPI [FPcm]	1 / 18 [7]	1 / 18 [7]	1 / 18 [7]	1 / 18 [7]
Indoor Coil—Fin Type	Louvered	Louvered	Louvered	Louvered
Tube Type	Rifled	Rifled	Rifled	Rifled
Tube Size in. [mm] OD	0.375 [9.5]	0.375 [9.5]	0.375 [9.5]	0.375 [9.5]
Face Area sq. ft. [sq. m]	5.54 [0.51]	5.54 [0.51]	5.54 [0.51]	5.54 [0.51]
Rows / FPI [FPcm]	2 / 15 [6]	2 / 15 [6]	2 / 15 [6]	2 / 15 [6]
Refrigerant Control	TX Valves	TX Valves	TX Valves	TX Valves
Drain Connection No./Size in. [mm]	1/0.75 [19.05]	1/0.75 [19.05]	1/0.75 [19.05]	1/0.75 [19.05]
Outdoor Fan—Type	Propeller	Propeller	Propeller	Propeller
No. Used/Diameter in. [mm]	1/22 [558.8]	1/22 [558.8]	1/22 [558.8]	1/22 [558.8]
Drive Type/No. Speeds	Direct/1	Direct/1	Direct/1	Direct/1
CFM [L/s]	2500 [1180]	2500 [1180]	2500 [1180]	2500 [1180]
No. Motors/HP	1 at 1/6 HP	1 at 1/6 HP	1 at 1/6 HP	1 at 1/6 HP
Motor RPM	850	850	850	850
Indoor Fan—Type	FC Centrifugal	FC Centrifugal	FC Centrifugal	FC Centrifugal
No. Used/Diameter in. [mm]	1/10x9 [254x229]	1/10x9 [254x229]	1/10x9 [254x229]	1/10x9 [254x229]
Drive Type	Direct	Direct	Direct	Direct
No. Speeds	Multiple	Multiple	Multiple	Multiple
No. Motors	1	1	1	1
Motor HP	1/2	1/2	1/2	1/2
Motor RPM	1050	1050	1050	1050
Motor Frame Size	48	48	48	48
Filter—Type	Field Supplied	Field Supplied	Field Supplied	Field Supplied
Furnished	No	No	No	No
(NO.) Size Recommended in. [mm x mm x mm]	(1)1x20x20 [25x508x508]	(1)1x20x20 [25x508x508]	(1)1x20x20 [25x508x508]	(1)1x20x20 [25x508x508]
Refrigerant Charge Oz. [g]	97.6 [2767]	97.6 [2767]	97.6 [2767]	97.6 [2767]
Weights				
Net Weight lbs. [kg]	454 [206]	454 [206]	454 [206]	454 [206]
Ship Weight lbs. [kg]	467 [212]	467 [212]	467 [212]	467 [212]

See Page 15 for Notes.

[] Designates Metric Conversions

NOMINAL SIZES 2-5 TONS [7.0-17.6 kW]

Model RGEA16 Series	036ACV062AA	036ACV06TAA	036ACV082AA	036ACV08TAA
Cooling Performance¹				
AHRI Net Cooling Capacity (2nd stage) Btu [kW]	34,200 [25910]	34,200 [25910]	34,200 [25910]	34,200 [25910]
SEER ²	15.9	15.9	15.9	15.9
EER (2nd stage)	12	12	12	12
AHRI Rated CFM (1st / 2nd stage) [L/s]	800/1200 [378/566]	800/1200 [378/566]	800/1200 [378/566]	800/1200 [378/566]
Net Sensible Capacity (2nd stage) Btu [kW]	25,910 [7.59]	25,910 [7.59]	25,910 [7.59]	25,910 [7.59]
Net Latent Capacity (2nd stage) Btu [kW]	8,290 [2.43]	8,290 [2.43]	8,290 [2.43]	8,290 [2.43]
Net System Power (1st / 2nd stage) kW	1.87/2.94	1.87/2.94	1.87/2.94	1.87/2.94
Heating Performance (Gas)³				
Heating Input Btu [kW] (1st Stage / 2nd Stage)	46,000/60,000 [13.48/17.58]	46,000/60,000 [13.48/17.58]	61,000/80,000 [17.87/23.44]	61,000/80,000 [17.87/23.44]
Heating Output Btu [kW] (1st Stage / 2nd Stage)	37,260/48,600 [10.92/14.24]	37,260/48,600 [10.92/14.24]	49,410/64,800 [14.48/18.99]	49,410/64,800 [14.48/18.99]
Temperature Rise Range °F [°C] (1st Stage / 2nd Stage)	10-40 [5.6-22.2] / 20-50 [11.1-27.8]	10-40 [5.6-22.2] / 20-50 [11.1-27.8]	15-45 [8.3-25] / 25-55 [13.9-30.6]	15-45 [8.3-25] / 25-55 [13.9-30.6]
AFUE % ⁴	0	0	0	0
Steady State Efficiency (%)	82	82	82	82
No. Burners	3	3	4	4
No. Stages	2	2	2	2
Gas Connection Pipe Size in. [mm]	0.5 [12.7]	0.5 [12.7]	0.5 [12.7]	0.5 [12.7]
Compressor				
No./Type	1/Scroll	1/Scroll	1/Scroll	1/Scroll
Outdoor Sound Rating (dB)⁵				
	76	76	76	76
Outdoor Coil—Fin Type				
Tube Type	Louvered	Louvered	Louvered	Louvered
Tube Size in. [mm] OD	Rifled	Rifled	Rifled	Rifled
Face Area sq. ft. [sq. m]	0.375 [9.5]	0.375 [9.5]	0.375 [9.5]	0.375 [9.5]
Rows / FPI [FPcm]	16.23 [1.51]	16.23 [1.51]	16.23 [1.51]	16.23 [1.51]
	2 / 22 [9]	2 / 22 [9]	2 / 22 [9]	2 / 22 [9]
Indoor Coil—Fin Type				
Tube Type	Louvered	Louvered	Louvered	Louvered
Tube Size in. [mm] OD	Rifled	Rifled	Rifled	Rifled
Face Area sq. ft. [sq. m]	0.375 [9.5]	0.375 [9.5]	0.375 [9.5]	0.375 [9.5]
Rows / FPI [FPcm]	7.39 [0.69]	7.39 [0.69]	7.39 [0.69]	7.39 [0.69]
	2 / 15 [6]	2 / 15 [6]	2 / 15 [6]	2 / 15 [6]
Refrigerant Control	TX Valves	TX Valves	TX Valves	TX Valves
Drain Connection No./Size in. [mm]	1/0.75 [19.05]	1/0.75 [19.05]	1/0.75 [19.05]	1/0.75 [19.05]
Outdoor Fan—Type				
No. Used/Diameter in. [mm]	Propeller	Propeller	Propeller	Propeller
Drive Type/No. Speeds	1/22 [558.8]	1/22 [558.8]	1/22 [558.8]	1/22 [558.8]
CFM [L/s]	Direct/1	Direct/1	Direct/1	Direct/1
No. Motors/HP	2700 [1274]	2700 [1274]	2700 [1274]	2700 [1274]
Motor RPM	1 at 1/6 HP	1 at 1/6 HP	1 at 1/6 HP	1 at 1/6 HP
	850	850	850	850
Indoor Fan—Type				
No. Used/Diameter in. [mm]	FC Centrifugal	FC Centrifugal	FC Centrifugal	FC Centrifugal
Drive Type	1/10x9 [254x229]	1/10x9 [254x229]	1/10x9 [254x229]	1/10x9 [254x229]
No. Speeds	Direct	Direct	Direct	Direct
No. Motors	Multiple	Multiple	Multiple	Multiple
Motor HP	1	1	1	1
Motor RPM	1/2	1/2	3/4	3/4
Motor Frame Size	1050	1050	1050	1050
	48	48	48	48
Filter—Type				
Furnished	Field Supplied	Field Supplied	Field Supplied	Field Supplied
(NO.) Size Recommended in. [mm x mm x mm]	No	No	No	No
	(1)1x24x24 [25x610x610]	(1)1x24x24 [25x610x610]	(1)1x24x24 [25x610x610]	(1)1x24x24 [25x610x610]
Refrigerant Charge Oz. [g]				
	155.2 [4400]	155.2 [4400]	155.2 [4400]	155.2 [4400]
Weights				
Net Weight lbs. [kg]	544 [247]	544 [247]	549 [249]	549 [249]
Ship Weight lbs. [kg]	558 [253]	558 [253]	558 [253]	558 [253]

CONTINUED →

See Page 15 for Notes.

[] Designates Metric Conversions

NOMINAL SIZES 2-5 TONS [7.0-17.6 kW]

Model RGEA16 Series	036ACV102AA	036ACV10TAA	036AJV062AB	036AJV06TAB
Cooling Performance¹				CONTINUED →
AHRI Net Cooling Capacity (2nd stage) Btu [kW]	34,200 [25910]	34,200 [25910]	34,200 [25910]	34,200 [25910]
SEER ²	15.9	15.9	15.9	15.9
EER (2nd stage)	12	12	12	12
AHRI Rated CFM (1st / 2nd stage) [L/s]	800/1200 [378/566]	800/1200 [378/566]	800/1200 [378/566]	800/1200 [378/566]
Net Sensible Capacity (2nd stage) Btu [kW]	25,910 [7.59]	25,910 [7.59]	25,910 [7.59]	25,910 [7.59]
Net Latent Capacity (2nd stage) Btu [kW]	8,290 [2.43]	8,290 [2.43]	8,290 [2.43]	8,290 [2.43]
Net System Power (1st / 2nd stage) kW	1.87/2.94	1.87/2.94	1.87/2.94	1.87/2.94
Heating Performance (Gas)³				
Heating Input Btu [kW] (1st Stage / 2nd Stage)	76,000/100,000 [22.27/29.3]	76,000/100,000 [22.27/29.3]	46,000/60,000 [13.48/17.58]	46,000/60,000 [13.48/17.58]
Heating Output Btu [kW] (1st Stage / 2nd Stage)	61,560/81,000 [18.04/23.73]	61,560/81,000 [18.04/23.73]	37,567/49,000 [11.01/14.36]	37,567/49,000 [11.01/14.36]
Temperature Rise Range °F [°C] (1st Stage / 2nd Stage)	25-55 [13.9-30.6] / 35-65 [19.4-36.1]	25-55 [13.9-30.6] / 35-65 [19.4-36.1]	10-40 [5.6-22.2] / 20-50 [11.1-27.8]	10-40 [5.6-22.2] / 20-50 [11.1-27.8]
AFUE % ⁴	0	0	81	81
Steady State Efficiency (%)	82	82	82	82
No. Burners	5	5	3	3
No. Stages	2	2	2	2
Gas Connection Pipe Size in. [mm]	0.5 [12.7]	0.5 [12.7]	0.5 [12.7]	0.5 [12.7]
Compressor				
No./Type	1/Scroll	1/Scroll	1/Scroll	1/Scroll
Outdoor Sound Rating (dB)⁵	76	76	76	76
Outdoor Coil—Fin Type	Louvered	Louvered	Louvered	Louvered
Tube Type	Rifled	Rifled	Rifled	Rifled
Tube Size in. [mm] OD	0.375 [9.5]	0.375 [9.5]	0.375 [9.5]	0.375 [9.5]
Face Area sq. ft. [sq. m]	16.23 [1.51]	16.23 [1.51]	16.23 [1.51]	16.23 [1.51]
Rows / FPI [FPcm]	2 / 22 [9]	2 / 22 [9]	2 / 22 [9]	2 / 22 [9]
Indoor Coil—Fin Type	Louvered	Louvered	Louvered	Louvered
Tube Type	Rifled	Rifled	Rifled	Rifled
Tube Size in. [mm] OD	0.375 [9.5]	0.375 [9.5]	0.375 [9.5]	0.375 [9.5]
Face Area sq. ft. [sq. m]	7.39 [0.69]	7.39 [0.69]	7.39 [0.69]	7.39 [0.69]
Rows / FPI [FPcm]	2 / 15 [6]	2 / 15 [6]	2 / 15 [6]	2 / 15 [6]
Refrigerant Control	TX Valves	TX Valves	TX Valves	TX Valves
Drain Connection No./Size in. [mm]	1/0.75 [19.05]	1/0.75 [19.05]	1/0.75 [19.05]	1/0.75 [19.05]
Outdoor Fan—Type	Propeller	Propeller	Propeller	Propeller
No. Used/Diameter in. [mm]	1/22 [558.8]	1/22 [558.8]	1/22 [558.8]	1/22 [558.8]
Drive Type/No. Speeds	Direct/1	Direct/1	Direct/1	Direct/1
CFM [L/s]	2700 [1274]	2700 [1274]	2700 [1274]	2700 [1274]
No. Motors/HP	1 at 1/6 HP	1 at 1/6 HP	1 at 1/6 HP	1 at 1/6 HP
Motor RPM	850	850	850	850
Indoor Fan—Type	FC Centrifugal	FC Centrifugal	FC Centrifugal	FC Centrifugal
No. Used/Diameter in. [mm]	1/10x9 [254x229]	1/10x9 [254x229]	1/10x9 [254x229]	1/10x9 [254x229]
Drive Type	Direct	Direct	Direct	Direct
No. Speeds	Multiple	Multiple	Multiple	Multiple
No. Motors	1	1	1	1
Motor HP	3/4	3/4	1/2	1/2
Motor RPM	1050	1050	1050	1050
Motor Frame Size	48	48	48	48
Filter—Type	Field Supplied	Field Supplied	Field Supplied	Field Supplied
Furnished	No	No	No	No
(NO.) Size Recommended in. [mm x mm x mm]	(1)1x24x24 [25x610x610]	(1)1x24x24 [25x610x610]	(1)1x24x24 [25x610x610]	(1)1x24x24 [25x610x610]
Refrigerant Charge Oz. [g]	155.2 [4400]	155.2 [4400]	155.2 [4400]	155.2 [4400]
Weights				
Net Weight lbs. [kg]	554 [251]	554 [251]	552 [250]	552 [250]
Ship Weight lbs. [kg]	558 [253]	558 [253]	558 [253]	558 [253]

See Page 15 for Notes.

[] Designates Metric Conversions

NOMINAL SIZES 2-5 TONS [7.0-17.6 kW]

Model RGEA16 Series	036AJV082AB	036AJV08TAA	036AJV08TAB	036AJV102AA
Cooling Performance¹				CONTINUED →
AHRI Net Cooling Capacity (2nd stage) Btu [kW]	34,200 [25910]	34,200 [25910]	34,200 [25910]	34,200 [25910]
SEER ²	15.9	15.9	15.9	15.9
EER (2nd stage)	12	12	12	12
AHRI Rated CFM (1st / 2nd stage) [L/s]	800/1200 [378/566]	800/1200 [378/566]	800/1200 [378/566]	800/1200 [378/566]
Net Sensible Capacity (2nd stage) Btu [kW]	25,910 [7.59]	25,910 [7.59]	25,910 [7.59]	25,910 [7.59]
Net Latent Capacity (2nd stage) Btu [kW]	8,290 [2.43]	8,290 [2.43]	8,290 [2.43]	8,290 [2.43]
Net System Power (1st / 2nd stage) kW	1.87/2.94	1.87/2.94	1.87/2.94	1.87/2.94
Heating Performance (Gas)³				
Heating Input Btu [kW] (1st Stage / 2nd Stage)	61,000/80,000 [17.87/23.44]	61,000/80,000 [17.87/23.44]	61,000/80,000 [17.87/23.44]	76,000/100,000 [22.27/29.3]
Heating Output Btu [kW] (1st Stage / 2nd Stage)	49,563/65,000 [14.52/19.04]	49,563/65,000 [14.52/19.04]	49,563/65,000 [14.52/19.04]	61,560/81,000 [18.04/23.73]
Temperature Rise Range °F [°C] (1st Stage / 2nd Stage)	15-45 [8.3-25] / 25-55 [13.9-30.6]	15-45 [8.3-25] / 25-55 [13.9-30.6]	15-45 [8.3-25] / 25-55 [13.9-30.6]	25-55 [13.9-30.6] / 35-65 [19.4-36.1]
AFUE % ⁴	81	81	81	81
Steady State Efficiency (%)	82	82	82	82
No. Burners	4	4	4	5
No. Stages	2	2	2	2
Gas Connection Pipe Size in. [mm]	0.5 [12.7]	0.5 [12.7]	0.5 [12.7]	0.5 [12.7]
Compressor				
No./Type	1/Scroll	1/Scroll	1/Scroll	1/Scroll
Outdoor Sound Rating (dB)⁵	76	76	76	76
Outdoor Coil—Fin Type	Louvered	Louvered	Louvered	Louvered
Tube Type	Rifled	Rifled	Rifled	Rifled
Tube Size in. [mm] OD	0.375 [9.5]	0.375 [9.5]	0.375 [9.5]	0.375 [9.5]
Face Area sq. ft. [sq. m]	16.23 [1.51]	16.23 [1.51]	16.23 [1.51]	16.23 [1.51]
Rows / FPI [FPcm]	2 / 22 [9]	2 / 22 [9]	2 / 22 [9]	2 / 22 [9]
Indoor Coil—Fin Type	Louvered	Louvered	Louvered	Louvered
Tube Type	Rifled	Rifled	Rifled	Rifled
Tube Size in. [mm] OD	0.375 [9.5]	0.375 [9.5]	0.375 [9.5]	0.375 [9.5]
Face Area sq. ft. [sq. m]	7.39 [0.69]	7.39 [0.69]	7.39 [0.69]	7.39 [0.69]
Rows / FPI [FPcm]	2 / 15 [6]	2 / 15 [6]	2 / 15 [6]	2 / 15 [6]
Refrigerant Control	TX Valves	TX Valves	TX Valves	TX Valves
Drain Connection No./Size in. [mm]	1/0.75 [19.05]	1/0.75 [19.05]	1/0.75 [19.05]	1/0.75 [19.05]
Outdoor Fan—Type	Propeller	Propeller	Propeller	Propeller
No. Used/Diameter in. [mm]	1/22 [558.8]	1/22 [558.8]	1/22 [558.8]	1/22 [558.8]
Drive Type/No. Speeds	Direct/1	Direct/1	Direct/1	Direct/1
CFM [L/s]	2700 [1274]	2700 [1274]	2700 [1274]	2700 [1274]
No. Motors/HP	1 at 1/6 HP	1 at 1/6 HP	1 at 1/6 HP	1 at 1/6 HP
Motor RPM	850	850	850	850
Indoor Fan—Type	FC Centrifugal	FC Centrifugal	FC Centrifugal	FC Centrifugal
No. Used/Diameter in. [mm]	1/10x9 [254x229]	1/10x9 [254x229]	1/10x9 [254x229]	1/10x9 [254x229]
Drive Type	Direct	Direct	Direct	Direct
No. Speeds	Multiple	Multiple	Multiple	Multiple
No. Motors	1	1	1	1
Motor HP	3/4	3/4	3/4	3/4
Motor RPM	1050	1050	1050	1050
Motor Frame Size	48	48	48	48
Filter—Type	Field Supplied	Field Supplied	Field Supplied	Field Supplied
Furnished	No	No	No	No
(NO.) Size Recommended in. [mm x mm x mm]	(1)1x24x24 [25x610x610]	(1)1x24x24 [25x610x610]	(1)1x24x24 [25x610x610]	(1)1x24x24 [25x610x610]
Refrigerant Charge Oz. [g]	155.2 [4400]	155.2 [4400]	155.2 [4400]	155.2 [4400]
Weights				
Net Weight lbs. [kg]	557 [253]	557 [253]	557 [253]	557 [253]
Ship Weight lbs. [kg]	558 [253]	558 [253]	558 [253]	558 [253]

See Page 15 for Notes.

[] Designates Metric Conversions

NOMINAL SIZES 2-5 TONS [7.0-17.6 kW]

Model RGEA16 Series	036AJV102AB	036AJV10TAA	036AJV10TAB	048ACV082AA
Cooling Performance¹				CONTINUED →
AHRI Net Cooling Capacity (2nd stage) Btu [kW]	34,200 [25910]	34,200 [25910]	34,200 [25910]	45,500 [13.33]
SEER ²	15.9	15.9	15.9	14.5
EER (2nd stage)	12	12	12	11
AHRI Rated CFM (1st / 2nd stage) [L/s]	800/1200 [378/566]	800/1200 [378/566]	800/1200 [378/566]	1050/1600 [495/755]
Net Sensible Capacity (2nd stage) Btu [kW]	25,910 [7.59]	25,910 [7.59]	25,910 [7.59]	33,370 [9.78]
Net Latent Capacity (2nd stage) Btu [kW]	8,290 [2.43]	8,290 [2.43]	8,290 [2.43]	12,130 [3.55]
Net System Power (1st / 2nd stage) kW	1.87/2.94	1.87/2.94	1.87/2.94	2.73/4.1
Heating Performance (Gas)³				
Heating Input Btu [kW] (1st Stage / 2nd Stage)	76,000/100,000 [22.27/29.3]	76,000/100,000 [22.27/29.3]	76,000/100,000 [22.27/29.3]	61,000/80,000 [17.87/23.44]
Heating Output Btu [kW] (1st Stage / 2nd Stage)	61,560/81,000 [18.04/23.73]	61,560/81,000 [18.04/23.73]	61,560/81,000 [18.04/23.73]	49,410/64,800 [14.48/18.99]
Temperature Rise Range °F [°C] (1st Stage / 2nd Stage)	25-55 [13.9-30.6] / 35-65 [19.4-36.1]	25-55 [13.9-30.6] / 35-65 [19.4-36.1]	25-55 [13.9-30.6] / 35-65 [19.4-36.1]	15-45 [8.3-25] / 25-55 [13.9-30.6]
AFUE % ⁴	81	81	81	0
Steady State Efficiency (%)	82	82	82	82
No. Burners	5	5	5	4
No. Stages	2	2	2	2
Gas Connection Pipe Size in. [mm]	0.5 [12.7]	0.5 [12.7]	0.5 [12.7]	0.5 [12.7]
Compressor				
No./Type	1/Scroll	1/Scroll	1/Scroll	1/Scroll
Outdoor Sound Rating (dB)⁵	76	76	76	78
Outdoor Coil—Fin Type	Louvered	Louvered	Louvered	Louvered
Tube Type	Rifled	Rifled	Rifled	Rifled
Tube Size in. [mm] OD	0.375 [9.5]	0.375 [9.5]	0.375 [9.5]	0.375 [9.5]
Face Area sq. ft. [sq. m]	16.23 [1.51]	16.23 [1.51]	16.23 [1.51]	16.23 [1.51]
Rows / FPI [FPCm]	2 / 22 [9]	2 / 22 [9]	2 / 22 [9]	2 / 22 [9]
Indoor Coil—Fin Type	Louvered	Louvered	Louvered	Louvered
Tube Type	Rifled	Rifled	Rifled	Rifled
Tube Size in. [mm] OD	0.375 [9.5]	0.375 [9.5]	0.375 [9.5]	0.375 [9.5]
Face Area sq. ft. [sq. m]	7.39 [0.69]	7.39 [0.69]	7.39 [0.69]	7.39 [0.69]
Rows / FPI [FPCm]	2 / 15 [6]	2 / 15 [6]	2 / 15 [6]	2 / 15 [6]
Refrigerant Control	TX Valves	TX Valves	TX Valves	TX Valves
Drain Connection No./Size in. [mm]	1/0.75 [19.05]	1/0.75 [19.05]	1/0.75 [19.05]	1/0.75 [19.05]
Outdoor Fan—Type	Propeller	Propeller	Propeller	Propeller
No. Used/Diameter in. [mm]	1/22 [558.8]	1/22 [558.8]	1/22 [558.8]	1/22 [558.8]
Drive Type/No. Speeds	Direct/1	Direct/1	Direct/1	Direct/1
CFM [L/s]	2700 [1274]	2700 [1274]	2700 [1274]	3300 [1557]
No. Motors/HP	1 at 1/6 HP	1 at 1/6 HP	1 at 1/6 HP	1 at 1/3 HP
Motor RPM	850	850	850	850
Indoor Fan—Type	FC Centrifugal	FC Centrifugal	FC Centrifugal	FC Centrifugal
No. Used/Diameter in. [mm]	1/10x9 [254x229]	1/10x9 [254x229]	1/10x9 [254x229]	1/10x9 [254x229]
Drive Type	Direct	Direct	Direct	Direct
No. Speeds	Multiple	Multiple	Multiple	Multiple
No. Motors	1	1	1	1
Motor HP	3/4	3/4	3/4	3/4
Motor RPM	1050	1050	1050	1050
Motor Frame Size	48	48	48	48
Filter—Type	Field Supplied	Field Supplied	Field Supplied	Field Supplied
Furnished	No	No	No	No
(NO.) Size Recommended in. [mm x mm x mm]	(1)1x24x24 [25x610x610]	(1)1x24x24 [25x610x610]	(1)1x24x24 [25x610x610]	(1)1x24x24 [25x610x610]
Refrigerant Charge Oz. [g]	155.2 [4400]	155.2 [4400]	155.2 [4400]	169.6 [4808]
Weights				
Net Weight lbs. [kg]	557 [253]	557 [253]	557 [253]	549 [249]
Ship Weight lbs. [kg]	558 [253]	558 [253]	558 [253]	562 [255]

See Page 15 for Notes.

[] Designates Metric Conversions

NOMINAL SIZES 2-5 TONS [7.0-17.6 kW]

Model RGEA16 Series	048ACV082AB	048ACV08TAA	048ACV102AA	048ACV10TAA
Cooling Performance¹				CONTINUED →
AHRI Net Cooling Capacity (2nd stage) Btu [kW]	45,500 [13.33]	45,500 [13.33]	45,500 [13.33]	45,500 [13.33]
SEER ²	14.5	14.5	14.5	14.5
EER (2nd stage)	11	11	11	11
AHRI Rated CFM (1st / 2nd stage) [L/s]	1050/1600 [495/755]	1050/1600 [495/755]	1050/1600 [495/755]	1050/1600 [495/755]
Net Sensible Capacity (2nd stage) Btu [kW]	33,370 [9.78]	33,370 [9.78]	33,370 [9.78]	33,370 [9.78]
Net Latent Capacity (2nd stage) Btu [kW]	12,130 [3.55]	12,130 [3.55]	12,130 [3.55]	12,130 [3.55]
Net System Power (1st / 2nd stage) kW	2.73/4.1	2.73/4.1	2.73/4.1	2.73/4.1
Heating Performance (Gas)³				
Heating Input Btu [kW] (1st Stage / 2nd Stage)	61,000/80,000 [17.87/23.44]	61,000/80,000 [17.87/23.44]	76,000/100,000 [22.27/29.3]	76,000/100,000 [22.27/29.3]
Heating Output Btu [kW] (1st Stage / 2nd Stage)	49,410/64,800 [14.48/18.99]	49,410/64,800 [14.48/18.99]	61,560/81,000 [18.04/23.73]	61,560/81,000 [18.04/23.73]
Temperature Rise Range °F [°C] (1st Stage / 2nd Stage)	15-45 [8.3-25] / 25-55 [13.9-30.6]	15-45 [8.3-25] / 25-55 [13.9-30.6]	25-55 [13.9-30.6] / 35-65 [19.4-36.1]	25-55 [13.9-30.6] / 35-65 [19.4-36.1]
AFUE % ⁴	0	0	0	0
Steady State Efficiency (%)	82	82	82	82
No. Burners	4	4	5	5
No. Stages	2	2	2	2
Gas Connection Pipe Size in. [mm]	0.5 [12.7]	0.5 [12.7]	0.5 [12.7]	0.5 [12.7]
Compressor				
No./Type	1/Scroll	1/Scroll	1/Scroll	1/Scroll
Outdoor Sound Rating (dB)⁵	78	78	78	78
Outdoor Coil—Fin Type	Louvered	Louvered	Louvered	Louvered
Tube Type	Rifled	Rifled	Rifled	Rifled
Tube Size in. [mm] OD	0.375 [9.5]	0.375 [9.5]	0.375 [9.5]	0.375 [9.5]
Face Area sq. ft. [sq. m]	16.23 [1.51]	16.23 [1.51]	16.23 [1.51]	16.23 [1.51]
Rows / FPI [FPcm]	2 / 22 [9]	2 / 22 [9]	2 / 22 [9]	2 / 22 [9]
Indoor Coil—Fin Type	Louvered	Louvered	Louvered	Louvered
Tube Type	Rifled	Rifled	Rifled	Rifled
Tube Size in. [mm] OD	0.375 [9.5]	0.375 [9.5]	0.375 [9.5]	0.375 [9.5]
Face Area sq. ft. [sq. m]	7.39 [0.69]	7.39 [0.69]	7.39 [0.69]	7.39 [0.69]
Rows / FPI [FPcm]	2 / 15 [6]	2 / 15 [6]	2 / 15 [6]	2 / 15 [6]
Refrigerant Control	TX Valves	TX Valves	TX Valves	TX Valves
Drain Connection No./Size in. [mm]	1/0.75 [19.05]	1/0.75 [19.05]	1/0.75 [19.05]	1/0.75 [19.05]
Outdoor Fan—Type	Propeller	Propeller	Propeller	Propeller
No. Used/Diameter in. [mm]	1/22 [558.8]	1/22 [558.8]	1/22 [558.8]	1/22 [558.8]
Drive Type/No. Speeds	Direct/1	Direct/1	Direct/1	Direct/1
CFM [L/s]	3300 [1557]	3300 [1557]	3300 [1557]	3300 [1557]
No. Motors/HP	1 at 1/3 HP	1 at 1/3 HP	1 at 1/3 HP	1 at 1/3 HP
Motor RPM	850	850	850	850
Indoor Fan—Type	FC Centrifugal	FC Centrifugal	FC Centrifugal	FC Centrifugal
No. Used/Diameter in. [mm]	1/10x9 [254x229]	1/10x9 [254x229]	1/10x9 [254x229]	1/10x9 [254x229]
Drive Type	Direct	Direct	Direct	Direct
No. Speeds	Multiple	Multiple	Multiple	Multiple
No. Motors	1	1	1	1
Motor HP	3/4	3/4	3/4	3/4
Motor RPM	1050	1050	1050	1050
Motor Frame Size	48	48	48	48
Filter—Type	Field Supplied	Field Supplied	Field Supplied	Field Supplied
Furnished	No	No	No	No
(NO.) Size Recommended in. [mm x mm x mm]	(1)1x24x24 [25x610x610]	(1)1x24x24 [25x610x610]	(1)1x24x24 [25x610x610]	(1)1x24x24 [25x610x610]
Refrigerant Charge Oz. [g]	169.6 [4808]	169.6 [4808]	169.6 [4808]	169.6 [4808]
Weights				
Net Weight lbs. [kg]	549 [249]	549 [249]	554 [251]	554 [251]
Ship Weight lbs. [kg]	562 [255]	562 [255]	562 [255]	562 [255]

See Page 15 for Notes.

[] Designates Metric Conversions

NOMINAL SIZES 2-5 TONS [7.0-17.6 kW]

Model RGEA16 Series	048AJV082AB	048AJV08TAB	048AJV102AB	048AJV10TAB
Cooling Performance¹				CONTINUED →
AHRI Net Cooling Capacity (2nd stage) Btu [kW]	45,500 [13.33]	45,500 [13.33]	45,500 [13.33]	45,500 [13.33]
SEER ²	14.5	14.5	14.5	14.5
EER (2nd stage)	11	11	11	11
AHRI Rated CFM (1st / 2nd stage) [L/s]	1050/1600 [495/755]	1050/1600 [495/755]	1050/1600 [495/755]	1050/1600 [495/755]
Net Sensible Capacity (2nd stage) Btu [kW]	33,370 [9.78]	33,370 [9.78]	33,370 [9.78]	33,370 [9.78]
Net Latent Capacity (2nd stage) Btu [kW]	12,130 [3.55]	12,130 [3.55]	12,130 [3.55]	12,130 [3.55]
Net System Power (1st / 2nd stage) kW	2.73/4.1	2.73/4.1	2.73/4.1	2.73/4.1
Heating Performance (Gas)³				
Heating Input Btu [kW] (1st Stage / 2nd Stage)	61,000/80,000 [17.87/23.44]	61,000/80,000 [17.87/23.44]	76,000/100,000 [22.27/29.3]	76,000/100,000 [22.27/29.3]
Heating Output Btu [kW] (1st Stage / 2nd Stage)	49,563/65,000 [14.52/19.04]	49,563/65,000 [14.52/19.04]	61,560/81,000 [18.04/23.73]	61,560/81,000 [18.04/23.73]
Temperature Rise Range °F [°C] (1st Stage / 2nd Stage)	15-45 [8.3-25] / 25-55 [13.9-30.6]	15-45 [8.3-25] / 25-55 [13.9-30.6]	25-55 [13.9-30.6] / 35-65 [19.4-36.1]	25-55 [13.9-30.6] / 35-65 [19.4-36.1]
AFUE % ⁴	81	81	81	81
Steady State Efficiency (%)	82	82	82	82
No. Burners	4	4	5	5
No. Stages	2	2	2	2
Gas Connection Pipe Size in. [mm]	0.5 [12.7]	0.5 [12.7]	0.5 [12.7]	0.5 [12.7]
Compressor				
No./Type	1/Scroll	1/Scroll	1/Scroll	1/Scroll
Outdoor Sound Rating (dB)⁵	78	78	78	78
Outdoor Coil—Fin Type	Louvered	Louvered	Louvered	Louvered
Tube Type	Rifled	Rifled	Rifled	Rifled
Tube Size in. [mm] OD	0.375 [9.5]	0.375 [9.5]	0.375 [9.5]	0.375 [9.5]
Face Area sq. ft. [sq. m]	16.23 [1.51]	16.23 [1.51]	16.23 [1.51]	16.23 [1.51]
Rows / FPI [FPCm]	2 / 22 [9]	2 / 22 [9]	2 / 22 [9]	2 / 22 [9]
Indoor Coil—Fin Type	Louvered	Louvered	Louvered	Louvered
Tube Type	Rifled	Rifled	Rifled	Rifled
Tube Size in. [mm] OD	0.375 [9.5]	0.375 [9.5]	0.375 [9.5]	0.375 [9.5]
Face Area sq. ft. [sq. m]	7.39 [0.69]	7.39 [0.69]	7.39 [0.69]	7.39 [0.69]
Rows / FPI [FPCm]	2 / 15 [6]	2 / 15 [6]	2 / 15 [6]	2 / 15 [6]
Refrigerant Control	TX Valves	TX Valves	TX Valves	TX Valves
Drain Connection No./Size in. [mm]	1/0.75 [19.05]	1/0.75 [19.05]	1/0.75 [19.05]	1/0.75 [19.05]
Outdoor Fan—Type	Propeller	Propeller	Propeller	Propeller
No. Used/Diameter in. [mm]	1/22 [558.8]	1/22 [558.8]	1/22 [558.8]	1/22 [558.8]
Drive Type/No. Speeds	Direct/1	Direct/1	Direct/1	Direct/1
CFM [L/s]	3300 [1557]	3300 [1557]	3300 [1557]	3300 [1557]
No. Motors/HP	1 at 1/3 HP	1 at 1/3 HP	1 at 1/3 HP	1 at 1/3 HP
Motor RPM	850	850	850	850
Indoor Fan—Type	FC Centrifugal	FC Centrifugal	FC Centrifugal	FC Centrifugal
No. Used/Diameter in. [mm]	1/10x9 [254x229]	1/10x9 [254x229]	1/10x9 [254x229]	1/10x9 [254x229]
Drive Type	Direct	Direct	Direct	Direct
No. Speeds	Multiple	Multiple	Multiple	Multiple
No. Motors	1	1	1	1
Motor HP	3/4	3/4	3/4	3/4
Motor RPM	1050	1050	1050	1050
Motor Frame Size	48	48	48	48
Filter—Type	Field Supplied	Field Supplied	Field Supplied	Field Supplied
Furnished	No	No	No	No
(NO.) Size Recommended in. [mm x mm x mm]	(1)1x24x24 [25x610x610]	(1)1x24x24 [25x610x610]	(1)1x24x24 [25x610x610]	(1)1x24x24 [25x610x610]
Refrigerant Charge Oz. [g]	169.6 [4808]	169.6 [4808]	169.6 [4808]	169.6 [4808]
Weights				
Net Weight lbs. [kg]	557 [253]	557 [253]	562 [255]	562 [255]
Ship Weight lbs. [kg]	562 [255]	562 [255]	562 [255]	562 [255]

See Page 15 for Notes.

[] Designates Metric Conversions

NOMINAL SIZES 2-5 TONS [7.0-17.6 kW]

Model RGEA16 Series	060ACV102AA	060ACV10TAA	060AJV102AB	060AJV10TAB
Cooling Performance¹				
AHRI Net Cooling Capacity (2nd stage) Btu [kW]	55,000 [16.12]	55,000 [16.12]	55,000 [16.12]	55,000 [16.12]
SEER ²	14	14	14	14
EER (2nd stage)	10.2	10.2	10.2	10.2
AHRI Rated CFM (1st / 2nd stage) [L/s]	1250/1850 [590/873]	1250/1850 [590/873]	1250/1850 [590/873]	1250/1850 [590/873]
Net Sensible Capacity (2nd stage) Btu [kW]	40,100 [11.75]	40,100 [11.75]	40,100 [11.75]	40,100 [11.75]
Net Latent Capacity (2nd stage) Btu [kW]	14,900 [4.37]	14,900 [4.37]	14,900 [4.37]	14,900 [4.37]
Net System Power (1st / 2nd stage) kW	3.48/5.4	3.48/5.4	3.48/5.4	3.48/5.4
Heating Performance (Gas)³				
Heating Input Btu [kW] (1st Stage / 2nd Stage)	76,000/100,000 [22.27/29.3]	76,000/100,000 [22.27/29.3]	76,000/100,000 [22.27/29.3]	76,000/100,000 [22.27/29.3]
Heating Output Btu [kW] (1st Stage / 2nd Stage)	61,560/81,000 [18.04/23.73]	61,560/81,000 [18.04/23.73]	61,560/81,000 [18.04/23.73]	61,560/81,000 [18.04/23.73]
Temperature Rise Range °F [°C] (1st Stage / 2nd Stage)	25-55 [13.9-30.6] / 35-65 [19.4-36.1]	25-55 [13.9-30.6] / 35-65 [19.4-36.1]	25-55 [13.9-30.6] / 35-65 [19.4-36.1]	22-55 [12.2-30.6] / 35-65 [19.4-36.1]
AFUE % ⁴	0	0	81	81
Steady State Efficiency (%)	82	82	82	82
No. Burners	5	5	5	5
No. Stages	2	2	2	2
Gas Connection Pipe Size in. [mm]	0.5 [12.7]	0.5 [12.7]	0.5 [12.7]	0.5 [12.7]
Compressor				
No./Type	1/Scroll	1/Scroll	1/Scroll	1/Scroll
Outdoor Sound Rating (dB)⁵				
	78	78	78	78
Outdoor Coil—Fin Type				
Tube Type	Louvered	Louvered	Louvered	Louvered
Tube Size in. [mm] OD	Rifled	Rifled	Rifled	Rifled
Face Area sq. ft. [sq. m]	0.375 [9.5]	0.375 [9.5]	0.375 [9.5]	0.375 [9.5]
Rows / FPI [FPcm]	16.23 [1.51]	16.23 [1.51]	16.23 [1.51]	16.23 [1.51]
	2 / 22 [9]	2 / 22 [9]	2 / 22 [9]	2 / 22 [9]
Indoor Coil—Fin Type				
Tube Type	Louvered	Louvered	Louvered	Louvered
Tube Size in. [mm] OD	Rifled	Rifled	Rifled	Rifled
Face Area sq. ft. [sq. m]	0.375 [9.5]	0.375 [9.5]	0.375 [9.5]	0.375 [9.5]
Rows / FPI [FPcm]	7.39 [0.69]	7.39 [0.69]	7.39 [0.69]	7.39 [0.69]
	2 / 15 [6]	2 / 15 [6]	2 / 15 [6]	2 / 15 [6]
Refrigerant Control	TX Valves	TX Valves	TX Valves	TX Valves
Drain Connection No./Size in. [mm]	1/0.75 [19.05]	1/0.75 [19.05]	1/0.75 [19.05]	1/0.75 [19.05]
Outdoor Fan—Type				
No. Used/Diameter in. [mm]	Propeller	Propeller	Propeller	Propeller
Drive Type/No. Speeds	1/22 [558.8]	1/22 [558.8]	1/22 [558.8]	1/22 [558.8]
CFM [L/s]	Direct/1	Direct/1	Direct/1	Direct/1
No. Motors/HP	3300 [1557]	3300 [1557]	3300 [1557]	3300 [1557]
Motor RPM	1 at 1/3 HP	1 at 1/3 HP	1 at 1/3 HP	1 at 1/3 HP
	1075	1075	1075	1075
Indoor Fan—Type				
No. Used/Diameter in. [mm]	FC Centrifugal	FC Centrifugal	FC Centrifugal	FC Centrifugal
Drive Type	1/12x9 [305x229]	1/12x9 [305x229]	1/12x9 [305x229]	1/12x9 [305x229]
No. Speeds	Direct	Direct	Direct	Direct
No. Motors	Multiple	Multiple	Multiple	Multiple
Motor HP	1	1	1	1
Motor RPM	1	1	1	1
Motor Frame Size	1050	1050	1050	1050
	48	48	48	48
Filter—Type				
Furnished	Field Supplied	Field Supplied	Field Supplied	Field Supplied
(NO.) Size Recommended in. [mm x mm x mm]	No	No	No	No
	(1)1x24x30 [25x610x762]	(1)1x24x30 [25x610x762]	(1)1x24x30 [25x610x762]	(1)1x24x30 [25x610x762]
Refrigerant Charge Oz. [g]				
	165.8 [4700]	165.8 [4700]	165.8 [4700]	165.8 [4700]
Weights				
Net Weight lbs. [kg]	571 [259]	571 [259]	583 [264]	583 [264]
Ship Weight lbs. [kg]	594 [269]	594 [269]	594 [269]	594 [269]

See Page 15 for Notes.

[] Designates Metric Conversions

NOTES:

1. Cooling Performance is rated at 95° F ambient, 80° F entering dry bulb, 67° F entering wet bulb. Gross capacity does not include the effect of fan motor heat. AHRI capacity is net and includes the effect of fan motor heat. Units are suitable for operation in CFM range shown in airflow tables. Units are certified in accordance with the Unitary Air Conditioner Equipment certification program, which is based on AHRI Standard 210/240 or 360.
2. EER and/or SEER are rated at AHRI conditions and in accordance with DOE test procedures.
3. Heating Performance limit settings and rating data were established and approved under laboratory test conditions using American National Standard Institute standards. Ratings shown are for elevations up to 2000 feet. For elevations above 2000 feet, ratings should be reduced at the rate of 4% for each 1000 feet above sea level.
4. AFUE is rated in accordance with DOE test procedures.
5. Outdoor Sound Rating shown is tested in accordance with AHRI Standard 270.

GROSS SYSTEMS PERFORMANCE DATA—RGEA16024A

ENTERING INDOOR AIR @ 80°F [26.7°C] dbE ①											
wbE		71°F [21.7°C]			67°F [19.4°C]			63°F [17.2°C]			
CFM [L/s]		880 [415]	800 [378]	720 [340]	880 [415]	800 [378]	720 [340]	880 [415]	800 [378]	720 [340]	
DR ①		0.18	0.16	0.14	0.18	0.16	0.14	0.18	0.16	0.14	
OUTDOOR DRY BULB TEMPERATURE °F [°C]	75 [23.9]	Total BTUH [kW] Sens BTUH [kW] Power	29.9 [8.8] 17.5 [5.1] 1.5	29.4 [8.6] 16.7 [4.9] 1.5	28.9 [8.5] 15.9 [4.7] 1.5	28.1 [8.2] 20.8 [6.1] 1.5	27.6 [8.1] 19.9 [5.8] 1.5	27.1 [8.0] 18.9 [5.5] 1.5	27.0 [7.9] 23.6 [6.9] 1.5	26.5 [7.8] 22.6 [6.6] 1.5	26.0 [7.6] 21.5 [6.3] 1.4
	80 [26.7]	Total BTUH [kW] Sens BTUH [kW] Power	29.1 [8.5] 16.9 [4.9] 1.6	28.6 [8.4] 16.1 [4.7] 1.6	28.0 [8.2] 15.4 [4.5] 1.6	27.3 [8.0] 20.2 [5.9] 1.6	26.8 [7.9] 19.3 [5.7] 1.6	26.3 [7.7] 18.4 [5.4] 1.6	26.1 [7.6] 23.0 [6.8] 1.5	25.6 [7.5] 22.0 [6.5] 1.5	25.2 [7.4] 21.0 [6.2] 1.5
	85 [29.4]	Total BTUH [kW] Sens BTUH [kW] Power	28.2 [8.3] 16.3 [4.8] 1.7	27.7 [8.1] 15.6 [4.6] 1.7	27.2 [8.0] 14.8 [4.4] 1.7	26.4 [7.7] 19.6 [5.8] 1.7	25.9 [7.6] 18.8 [5.5] 1.6	25.5 [7.5] 17.9 [5.2] 1.6	25.2 [7.4] 22.5 [6.6] 1.6	24.8 [7.3] 21.5 [6.3] 1.6	24.3 [7.1] 20.5 [6.0] 1.6
	90 [32.2]	Total BTUH [kW] Sens BTUH [kW] Power	27.3 [8.0] 15.8 [4.6] 1.8	26.8 [7.9] 15.1 [4.4] 1.8	26.3 [7.7] 14.4 [4.2] 1.7	25.5 [7.5] 19.1 [5.6] 1.7	25.1 [7.3] 18.3 [5.3] 1.7	24.6 [7.2] 17.4 [5.1] 1.7	24.3 [7.1] 22.0 [6.4] 1.7	23.9 [7.0] 21.0 [6.1] 1.7	23.5 [6.9] 20.0 [5.9] 1.7
	95 [35]	Total BTUH [kW] Sens BTUH [kW] Power	26.4 [7.7] 15.3 [4.5] 1.9	25.9 [7.6] 14.6 [4.3] 1.8	25.5 [7.5] 13.9 [4.1] 1.8	24.6 [7.2] 18.6 [5.5] 1.8	24.2 [7.1] 17.8 [5.2] 1.8	23.7 [7.0] 17.0 [5.0] 1.8	23.4 [6.9] 21.5 [6.3] 1.8	23.0 [6.7] 20.5 [6.0] 1.8	22.6 [6.6] 19.6 [5.7] 1.8
	100 [37.8]	Total BTUH [kW] Sens BTUH [kW] Power	25.5 [7.5] 14.9 [4.4] 2.0	25.0 [7.3] 14.2 [4.2] 1.9	24.6 [7.2] 13.5 [4.0] 1.9	23.7 [6.9] 18.2 [5.3] 1.9	23.3 [6.8] 17.4 [5.1] 1.9	22.9 [6.7] 16.6 [4.9] 1.9	22.5 [6.6] 21.0 [6.2] 1.9	22.1 [6.5] 20.1 [5.9] 1.9	21.7 [6.4] 19.2 [5.6] 1.8
	105 [40.6]	Total BTUH [kW] Sens BTUH [kW] Power	24.6 [7.2] 14.4 [4.2] 2.0	24.2 [7.1] 13.8 [4.0] 2.0	23.7 [6.9] 13.2 [3.9] 2.0	22.8 [6.7] 17.8 [5.2] 2.0	22.4 [6.6] 17.0 [5.0] 2.0	22.0 [6.4] 16.2 [4.7] 2.0	21.6 [6.3] 20.6 [6.0] 2.0	21.2 [6.2] 19.7 [5.8] 2.0	20.8 [6.1] 18.8 [5.5] 1.9
	110 [43.3]	Total BTUH [kW] Sens BTUH [kW] Power	23.7 [6.9] 14.1 [4.1] 2.1	23.2 [6.8] 13.5 [3.9] 2.1	22.8 [6.7] 12.8 [3.8] 2.1	21.9 [6.4] 17.4 [5.1] 2.1	21.5 [6.3] 16.6 [4.9] 2.1	21.1 [6.2] 15.9 [4.6] 2.1	20.7 [6.1] 20.3 [5.9] 2.1	20.3 [6.0] 19.4 [5.7] 2.1	19.9 [5.8] 18.5 [5.4] 2.0
	115 [46.1]	Total BTUH [kW] Sens BTUH [kW] Power	22.7 [6.7] 13.8 [4.0] 2.3	22.3 [6.5] 13.1 [3.9] 2.2	21.9 [6.4] 12.5 [3.7] 2.2	20.9 [6.1] 17.1 [5.0] 2.2	20.6 [6.0] 16.3 [4.8] 2.2	20.2 [5.9] 15.6 [4.6] 2.2	19.7 [5.8] 19.7 [5.8] 2.2	19.4 [5.7] 19.0 [5.6] 2.2	19.0 [5.6] 18.2 [5.3] 2.1
	120 [48.9]	Total BTUH [kW] Sens BTUH [kW] Power	21.8 [6.4] 13.5 [3.9] 2.4	21.4 [6.3] 12.9 [3.8] 2.3	21.0 [6.2] 12.3 [3.6] 2.3	20.0 [5.9] 16.8 [4.9] 2.3	19.6 [5.8] 16.0 [4.7] 2.3	19.3 [5.7] 15.3 [4.5] 2.3	18.8 [5.5] 18.8 [5.5] 2.3	18.5 [5.4] 18.5 [5.4] 2.3	18.1 [5.3] 17.9 [5.2] 2.2
	125 [51.7]	Total BTUH [kW] Sens BTUH [kW] Power	20.8 [6.1] 13.2 [3.9] 2.5	20.5 [6.0] 12.6 [3.7] 2.5	20.1 [5.9] 12.0 [3.5] 2.4	19.0 [5.6] 16.5 [4.8] 2.4	18.7 [5.5] 15.8 [4.6] 2.4	18.4 [5.4] 15.1 [4.4] 2.4	17.9 [5.2] 17.9 [5.2] 2.4	17.5 [5.1] 17.5 [5.1] 2.4	17.2 [5.0] 17.2 [5.0] 2.4

DR —Depression ratio
dbE —Entering air dry bulb
wbE —Entering air wet bulb

Total —Total capacity x 1000 BTUH
Sens —Sensible capacity x 1000 BTUH
Power —kW input

NOTES: ① When the entering air dry bulb is other than 80°F [27°C], adjust the sensible capacity from the table by adding [1.10 x CFM x (1 – DR) x (dbE – 80)].

[] Designates Metric Conversions

GROSS SYSTEMS PERFORMANCE DATA—RGEA16036A

ENTERING INDOOR AIR @ 80°F [26.7°C] dbE ①											
wbE		71°F [21.7°C]			67°F [19.4°C]			63°F [17.2°C]			
CFM [L/s]		1320 [623]	1200 [566]	1080 [510]	1320 [623]	1200 [566]	1080 [510]	1320 [623]	1200 [566]	1080 [510]	
DR ①		0.11	0.09	0.07	0.11	0.09	0.07	0.11	0.09	0.07	
OUTDOOR DRY BULB TEMPERATURE °F [°C]	75 [23.9]	Total BTUH [kW] Sens BTUH [kW] Power	45.1 [13.2] 28.0 [8.2] 2.3	44.3 [13.0] 26.7 [7.8] 2.2	43.5 [12.8] 25.5 [7.5] 2.2	42.4 [12.4] 32.2 [9.4] 2.2	41.6 [12.2] 30.7 [9.0] 2.2	40.9 [12.0] 29.3 [8.6] 2.2	39.8 [11.7] 34.6 [10.1] 2.1	39.1 [11.5] 33.0 [9.7] 2.1	38.4 [11.2] 31.5 [9.2] 2.1
	80 [26.7]	Total BTUH [kW] Sens BTUH [kW] Power	44.0 [12.9] 27.3 [8.0] 2.4	43.2 [12.7] 26.1 [7.6] 2.4	42.4 [12.4] 24.9 [7.3] 2.3	41.3 [12.1] 31.5 [9.2] 2.3	40.5 [11.9] 30.1 [8.8] 2.3	39.8 [11.7] 28.7 [8.4] 2.3	38.7 [11.3] 33.9 [9.9] 2.2	38.0 [11.1] 32.4 [9.5] 2.2	37.3 [10.9] 30.9 [9.0] 2.2
	85 [29.4]	Total BTUH [kW] Sens BTUH [kW] Power	42.8 [12.5] 26.6 [7.8] 2.5	42.1 [12.3] 25.4 [7.4] 2.5	41.3 [12.1] 24.2 [7.1] 2.5	40.1 [11.7] 30.8 [9.0] 2.4	39.4 [11.5] 29.4 [8.6] 2.4	38.7 [11.3] 28.1 [8.2] 2.4	37.5 [11.0] 33.2 [9.7] 2.4	36.8 [10.8] 31.7 [9.3] 2.3	36.1 [10.6] 30.2 [8.9] 2.3
	90 [32.2]	Total BTUH [kW] Sens BTUH [kW] Power	41.6 [12.2] 25.9 [7.6] 2.7	40.8 [12.0] 24.8 [7.3] 2.6	40.1 [11.7] 23.6 [6.9] 2.6	38.8 [11.4] 30.1 [8.8] 2.6	38.1 [11.2] 28.8 [8.4] 2.6	37.4 [11.0] 27.4 [8.0] 2.5	36.2 [10.6] 32.5 [9.5] 2.5	35.6 [10.4] 31.0 [9.1] 2.5	34.9 [10.2] 29.6 [8.7] 2.5
	95 [35]	Total BTUH [kW] Sens BTUH [kW] Power	40.2 [11.8] 25.2 [7.4] 2.8	39.5 [11.6] 24.1 [7.1] 2.8	38.8 [11.4] 23.0 [6.7] 2.8	37.5 [11.0] 29.4 [8.6] 2.7	36.8 [10.8] 28.1 [8.2] 2.7	36.1 [10.6] 26.8 [7.8] 2.7	34.9 [10.2] 31.8 [9.3] 2.7	34.2 [10.0] 30.4 [8.9] 2.6	33.6 [9.9] 28.9 [8.5] 2.6
	100 [37.8]	Total BTUH [kW] Sens BTUH [kW] Power	38.8 [11.4] 24.5 [7.2] 3.0	38.1 [11.2] 23.4 [6.9] 2.9	37.4 [11.0] 22.3 [6.5] 2.9	36.1 [10.6] 28.7 [8.4] 2.9	35.4 [10.4] 27.4 [8.0] 2.9	34.8 [10.2] 26.1 [7.7] 2.8	33.5 [9.8] 31.1 [9.1] 2.8	32.9 [9.6] 29.7 [8.7] 2.8	32.3 [9.5] 28.3 [8.3] 2.8
	105 [40.6]	Total BTUH [kW] Sens BTUH [kW] Power	37.3 [10.9] 23.8 [7.0] 3.1	36.6 [10.7] 22.7 [6.7] 3.1	36.0 [10.5] 21.6 [6.3] 3.1	34.6 [10.1] 28.0 [8.2] 3.0	34.0 [10.0] 26.7 [7.8] 3.0	33.3 [9.8] 25.5 [7.5] 3.0	32.0 [9.4] 30.3 [8.9] 3.0	31.4 [9.2] 29.0 [8.5] 2.9	30.8 [9.0] 27.6 [8.1] 2.9
	110 [43.3]	Total BTUH [kW] Sens BTUH [kW] Power	35.8 [10.5] 23.0 [6.8] 3.3	35.1 [10.3] 22.0 [6.5] 3.3	34.5 [10.1] 21.0 [6.1] 3.2	33.0 [9.7] 27.2 [8.0] 3.2	32.4 [9.5] 26.0 [7.6] 3.2	31.8 [9.3] 24.8 [7.3] 3.2	30.4 [8.9] 29.6 [8.7] 3.1	29.9 [8.8] 28.3 [8.3] 3.1	29.3 [8.6] 27.0 [7.9] 3.1
	115 [46.1]	Total BTUH [kW] Sens BTUH [kW] Power	34.1 [10.0] 22.3 [6.5] 3.5	33.5 [9.8] 21.3 [6.2] 3.4	32.9 [9.6] 20.3 [6.0] 3.4	31.4 [9.2] 26.5 [7.8] 3.4	30.8 [9.0] 25.3 [7.4] 3.4	30.3 [8.9] 24.1 [7.1] 3.3	28.8 [8.4] 28.8 [8.4] 3.3	28.3 [8.3] 27.6 [8.1] 3.3	27.8 [8.1] 26.3 [7.7] 3.3
	120 [48.9]	Total BTUH [kW] Sens BTUH [kW] Power	32.4 [9.5] 21.6 [6.3] 3.6	31.8 [9.3] 20.6 [6.0] 3.6	31.3 [9.2] 19.6 [5.8] 3.6	29.7 [8.7] 25.8 [7.5] 3.6	29.2 [8.5] 24.6 [7.2] 3.5	28.6 [8.4] 23.5 [6.9] 3.5	27.1 [7.9] 27.1 [7.9] 3.5	26.6 [7.8] 26.6 [7.8] 3.5	26.1 [7.7] 25.6 [7.5] 3.4
125 [51.7]	Total BTUH [kW] Sens BTUH [kW] Power	30.7 [9.0] 20.8 [6.1] 3.8	30.1 [8.8] 19.9 [5.8] 3.8	29.6 [8.7] 19.0 [5.6] 3.8	27.9 [8.2] 25.0 [7.3] 3.8	27.4 [8.0] 23.9 [7.0] 3.7	26.9 [7.9] 22.8 [6.7] 3.7	25.3 [7.4] 25.3 [7.4] 3.7	24.9 [7.3] 24.9 [7.3] 3.7	24.4 [7.2] 24.4 [7.2] 3.6	

DR —Depression ratio
dbE —Entering air dry bulb
wbE —Entering air wet bulb

Total —Total capacity x 1000 BTUH
Sens —Sensible capacity x 1000 BTUH
Power —KW input

NOTES: ① When the entering air dry bulb is other than 80°F [27°C], adjust the sensible capacity from the table by adding [1.10 x CFM x (1 - DR) x (dbE - 80)].

[] Designates Metric Conversions

GROSS SYSTEMS PERFORMANCE DATA—RGEA16048A

		ENTERING INDOOR AIR @ 80°F [26.7°C] dbE ①									
wbE		71°F [21.7°C]			67°F [19.4°C]			63°F [17.2°C]			
CFM [L/s]		1760 [831]	1600 [755]	1440 [680]	1760 [831]	1600 [755]	1440 [680]	1760 [831]	1600 [755]	1440 [680]	
DR ①		0.16	0.14	0.12	0.16	0.14	0.12	0.16	0.14	0.12	
OUTDOOR DRY BULB TEMPERATURE °F [°C]	75 [23.9]	Total BTUH [kW] Sens BTUH [kW] Power	59.8 [17.5] 35.3 [10.3] 3.1	58.7 [17.2] 33.7 [9.9] 3.1	57.6 [16.9] 32.1 [9.4] 3.0	55.8 [16.3] 41.0 [12.0] 3.0	54.8 [16.1] 39.1 [11.5] 3.0	53.8 [15.8] 37.3 [10.9] 3.0	52.4 [15.3] 45.3 [13.3] 2.9	51.4 [15.1] 43.3 [12.7] 2.9	50.5 [14.8] 41.2 [12.1] 2.9
	80 [26.7]	Total BTUH [kW] Sens BTUH [kW] Power	58.3 [17.1] 34.5 [10.1] 3.2	57.3 [16.8] 33.0 [9.7] 3.2	56.2 [16.5] 31.5 [9.2] 3.2	54.3 [15.9] 40.2 [11.8] 3.2	53.3 [15.6] 38.4 [11.3] 3.1	52.4 [15.3] 36.6 [10.7] 3.1	50.9 [14.9] 44.5 [13.0] 3.1	50.0 [14.7] 42.5 [12.5] 3.0	49.1 [14.4] 40.6 [11.9] 3.0
	85 [29.4]	Total BTUH [kW] Sens BTUH [kW] Power	56.8 [16.6] 33.8 [9.9] 3.4	55.8 [16.3] 32.3 [9.5] 3.4	54.7 [16.0] 30.8 [9.0] 3.3	52.8 [15.5] 39.4 [11.6] 3.3	51.8 [15.2] 37.7 [11.0] 3.3	50.9 [14.9] 35.9 [10.5] 3.2	49.4 [14.5] 43.8 [12.8] 3.2	48.5 [14.2] 41.8 [12.3] 3.2	47.6 [14.0] 39.9 [11.7] 3.2
	90 [32.2]	Total BTUH [kW] Sens BTUH [kW] Power	55.2 [16.2] 33.0 [9.7] 3.6	54.2 [15.9] 31.5 [9.2] 3.5	53.2 [15.6] 30.0 [8.8] 3.5	51.2 [15.0] 38.6 [11.3] 3.5	50.3 [14.7] 36.9 [10.8] 3.4	49.4 [14.5] 35.2 [10.3] 3.4	47.8 [14.0] 43.0 [12.6] 3.4	46.9 [13.8] 41.1 [12.0] 3.4	46.1 [13.5] 39.1 [11.5] 3.3
	95 [35]	Total BTUH [kW] Sens BTUH [kW] Power	53.5 [15.7] 32.2 [9.4] 3.7	52.6 [15.4] 30.7 [9.0] 3.7	51.6 [15.1] 29.3 [8.6] 3.7	49.6 [14.5] 37.8 [11.1] 3.6	48.7 [14.3] 36.1 [10.6] 3.6	47.8 [14.0] 34.5 [10.1] 3.6	46.1 [13.5] 42.1 [12.4] 3.6	45.3 [13.3] 40.3 [11.8] 3.5	44.5 [13.0] 38.4 [11.3] 3.5
	100 [37.8]	Total BTUH [kW] Sens BTUH [kW] Power	51.8 [15.2] 31.3 [9.2] 3.9	50.9 [14.9] 29.9 [8.8] 3.9	50.0 [14.6] 28.5 [8.4] 3.8	47.8 [14.0] 37.0 [10.8] 3.8	47.0 [13.8] 35.3 [10.4] 3.8	46.1 [13.5] 33.7 [9.9] 3.8	44.4 [13.0] 41.3 [12.1] 3.7	43.6 [12.8] 39.5 [11.6] 3.7	42.9 [12.6] 37.6 [11.0] 3.7
	105 [40.6]	Total BTUH [kW] Sens BTUH [kW] Power	50.1 [14.7] 30.5 [8.9] 4.1	49.2 [14.4] 29.1 [8.5] 4.1	48.3 [14.1] 27.7 [8.1] 4.0	46.1 [13.5] 36.1 [10.6] 4.0	45.3 [13.3] 34.5 [10.1] 4.0	44.4 [13.0] 32.9 [9.6] 3.9	42.7 [12.5] 40.4 [11.9] 3.9	41.9 [12.3] 38.6 [11.3] 3.9	41.2 [12.1] 36.8 [10.8] 3.9
	110 [43.3]	Total BTUH [kW] Sens BTUH [kW] Power	48.2 [14.1] 29.6 [8.7] 4.3	47.4 [13.9] 28.3 [8.3] 4.3	46.5 [13.6] 26.9 [7.9] 4.2	44.3 [13.0] 35.2 [10.3] 4.2	43.5 [12.7] 33.7 [9.9] 4.2	42.7 [12.5] 32.1 [9.4] 4.1	40.9 [12.0] 39.6 [11.6] 4.1	40.1 [11.8] 37.8 [11.1] 4.1	39.4 [11.5] 36.0 [10.6] 4.1
	115 [46.1]	Total BTUH [kW] Sens BTUH [kW] Power	46.4 [13.6] 28.7 [8.4] 4.5	45.5 [13.3] 27.4 [8.0] 4.5	44.7 [13.1] 26.1 [7.7] 4.4	42.4 [12.4] 34.3 [10.1] 4.4	41.6 [12.2] 32.8 [9.6] 4.4	40.9 [12.0] 31.3 [9.2] 4.4	39.0 [11.4] 38.6 [11.3] 4.3	38.3 [11.2] 36.9 [10.8] 4.3	37.6 [11.0] 35.2 [10.3] 4.3
	120 [48.9]	Total BTUH [kW] Sens BTUH [kW] Power	44.4 [13.0] 27.7 [8.1] 4.7	43.6 [12.8] 26.5 [7.8] 4.7	42.8 [12.6] 25.3 [7.4] 4.7	40.5 [11.9] 33.4 [9.8] 4.7	39.7 [11.6] 31.9 [9.4] 4.6	39.0 [11.4] 30.4 [8.9] 4.6	37.0 [10.9] 37.0 [10.9] 4.6	36.4 [10.7] 36.0 [10.6] 4.5	35.7 [10.5] 34.4 [10.1] 4.5
125 [51.7]	Total BTUH [kW] Sens BTUH [kW] Power	42.4 [12.4] 26.8 [7.8] 5.0	41.7 [12.2] 25.6 [7.5] 4.9	40.9 [12.0] 24.4 [7.1] 4.9	38.5 [11.3] 32.4 [9.5] 4.9	37.8 [11.1] 31.0 [9.1] 4.8	37.1 [10.9] 29.5 [8.7] 4.8	35.1 [10.3] 35.1 [10.3] 4.8	34.4 [10.1] 34.4 [10.1] 4.8	33.8 [9.9] 33.5 [9.8] 4.7	

DR —Depression ratio
dbE —Entering air dry bulb
wbE —Entering air wet bulb

Total —Total capacity x 1000 BTUH
Sens —Sensible capacity x 1000 BTUH
Power —kW input

NOTES: ① When the entering air dry bulb is other than 80°F [27°C], adjust the sensible capacity from the table by adding [1.10 x CFM x (1 - DR) x (dbE - 80)].

[] Designates Metric Conversions

GROSS SYSTEMS PERFORMANCE DATA—RGEA16060A

ENTERING INDOOR AIR @ 80°F [26.7°C] dbE ①											
wbE		71°F [21.7°C]			67°F [19.4°C]			63°F [17.2°C]			
CFM [L/s]		2030 [958]	1850 [873]	1660 [783]	2030 [958]	1850 [873]	1660 [783]	2030 [958]	1850 [873]	1660 [783]	
DR ①		0.11	0.09	0.07	0.11	0.09	0.07	0.11	0.09	0.07	
OUTDOOR DRY BULB TEMPERATURE °F [°C]	75 [23.9]	Total BTUH [kW] Sens BTUH [kW] Power	73.1 [21.4] 42.8 [12.6] 4.1	71.8 [21.0] 41.0 [12.0] 4.0	70.5 [20.6] 39.0 [11.4] 4.0	68.8 [20.2] 50.1 [14.7] 3.9	67.6 [19.8] 47.9 [14.0] 3.9	66.4 [19.5] 45.6 [13.4] 3.9	65.0 [19.0] 55.4 [16.2] 3.8	63.9 [18.7] 53.0 [15.5] 3.8	62.7 [18.4] 50.4 [14.8] 3.8
	80 [26.7]	Total BTUH [kW] Sens BTUH [kW] Power	71.5 [20.9] 42.3 [12.4] 4.3	70.2 [20.6] 40.4 [11.8] 4.2	68.9 [20.2] 38.5 [11.3] 4.2	67.2 [19.7] 49.5 [14.5] 4.1	66.1 [19.4] 47.4 [13.9] 4.1	64.8 [19.0] 45.1 [13.2] 4.1	63.4 [18.6] 54.8 [16.1] 4.0	62.3 [18.3] 52.4 [15.4] 4.0	61.1 [17.9] 49.9 [14.6] 3.9
	85 [29.4]	Total BTUH [kW] Sens BTUH [kW] Power	69.7 [20.4] 41.5 [12.2] 4.4	68.5 [20.1] 39.7 [11.6] 4.4	67.2 [19.7] 37.8 [11.1] 4.4	65.5 [19.2] 48.8 [14.3] 4.3	64.3 [18.9] 46.6 [13.7] 4.3	63.1 [18.5] 44.4 [13.0] 4.2	61.6 [18.1] 54.0 [15.8] 4.2	60.6 [17.7] 51.7 [15.1] 4.2	59.4 [17.4] 49.2 [14.4] 4.1
	90 [32.2]	Total BTUH [kW] Sens BTUH [kW] Power	67.8 [19.9] 40.6 [11.9] 4.6	66.6 [19.5] 38.8 [11.4] 4.6	65.4 [19.2] 37.0 [10.8] 4.6	63.6 [18.6] 47.8 [14.0] 4.5	62.5 [18.3] 45.8 [13.4] 4.5	61.3 [18.0] 43.6 [12.8] 4.4	59.7 [17.5] 53.1 [15.6] 4.4	58.7 [17.2] 50.8 [14.9] 4.3	57.6 [16.9] 48.4 [14.2] 4.3
	95 [35]	Total BTUH [kW] Sens BTUH [kW] Power	65.7 [19.3] 39.5 [11.6] 4.9	64.6 [18.9] 37.8 [11.1] 4.8	63.4 [18.6] 36.0 [10.5] 4.8	61.5 [18.0] 46.8 [13.7] 4.7	60.4 [17.7] 44.7 [13.1] 4.7	59.3 [17.4] 42.6 [12.5] 4.6	57.7 [16.9] 52.0 [15.2] 4.6	56.7 [16.6] 49.8 [14.6] 4.6	55.6 [16.3] 47.4 [13.9] 4.5
	100 [37.8]	Total BTUH [kW] Sens BTUH [kW] Power	63.5 [18.6] 38.3 [11.2] 5.1	62.4 [18.3] 36.6 [10.7] 5.0	61.3 [18.0] 34.8 [10.2] 5.0	59.3 [17.4] 45.5 [13.3] 4.9	58.3 [17.1] 43.5 [12.8] 4.9	57.2 [16.8] 41.4 [12.1] 4.9	55.4 [16.2] 50.8 [14.9] 4.8	54.5 [16.0] 48.6 [14.2] 4.8	53.5 [15.7] 46.2 [13.6] 4.7
	105 [40.6]	Total BTUH [kW] Sens BTUH [kW] Power	61.2 [17.9] 36.8 [10.8] 5.3	60.1 [17.6] 35.2 [10.3] 5.3	59.0 [17.3] 33.5 [9.8] 5.2	56.9 [16.7] 44.1 [12.9] 5.2	55.9 [16.4] 42.2 [12.4] 5.1	54.9 [16.1] 40.1 [11.8] 5.1	53.1 [15.6] 49.4 [14.5] 5.1	52.2 [15.3] 47.2 [13.8] 5.0	51.2 [15.0] 44.9 [13.2] 5.0
	110 [43.3]	Total BTUH [kW] Sens BTUH [kW] Power	58.6 [17.2] 35.2 [10.3] 5.6	57.6 [16.9] 33.7 [9.9] 5.5	56.5 [16.6] 32.1 [9.4] 5.5	54.4 [15.9] 42.5 [12.4] 5.4	53.4 [15.7] 40.6 [11.9] 5.4	52.4 [15.4] 38.7 [11.3] 5.3	50.5 [14.8] 47.8 [14.0] 5.3	49.7 [14.6] 45.7 [13.4] 5.3	48.7 [14.3] 43.5 [12.7] 5.2
	115 [46.1]	Total BTUH [kW] Sens BTUH [kW] Power	55.9 [16.4] 33.5 [9.8] 5.8	55.0 [16.1] 32.0 [9.4] 5.8	53.9 [15.8] 30.5 [8.9] 5.7	51.7 [15.2] 40.7 [11.9] 5.7	50.8 [14.9] 38.9 [11.4] 5.6	49.9 [14.6] 37.1 [10.9] 5.6	47.9 [14.0] 46.0 [13.5] 5.6	47.0 [13.8] 44.0 [12.9] 5.5	46.2 [13.5] 41.9 [12.3] 5.5
	120 [48.9]	Total BTUH [kW] Sens BTUH [kW] Power	53.1 [15.6] 31.5 [9.2] 6.1	52.2 [15.3] 30.2 [8.8] 6.0	51.2 [15.0] 28.7 [8.4] 6.0	48.9 [14.3] 38.8 [11.4] 6.0	48.0 [14.1] 37.1 [10.9] 5.9	47.1 [13.8] 35.3 [10.4] 5.8	45.0 [13.2] 44.1 [12.9] 5.8	44.2 [13.0] 42.2 [12.4] 5.8	43.4 [12.7] 40.1 [11.8] 5.7
	125 [51.7]	Total BTUH [kW] Sens BTUH [kW] Power	50.1 [14.7] 29.4 [8.6] 6.4	49.2 [14.4] 28.2 [8.3] 6.3	48.3 [14.2] 26.8 [7.9] 6.2	45.9 [13.4] 36.7 [10.7] 6.2	45.1 [13.2] 35.1 [10.3] 6.2	44.2 [13.0] 33.4 [9.8] 6.1	42.0 [12.3] 42.0 [12.3] 6.1	41.3 [12.1] 40.1 [11.8] 6.1	40.5 [11.9] 38.2 [11.2] 6.0

DR —Depression ratio
dbE —Entering air dry bulb
wbE —Entering air wet bulb

Total —Total capacity x 1000 BTUH
Sens —Sensible capacity x 1000 BTUH
Power —KW input

NOTES: ① When the entering air dry bulb is other than 80°F [27°C], adjust the sensible capacity from the table by adding [1.10 x CFM x (1 - DR) x (dbE - 80)].

[] Designates Metric Conversions

INDOOR AIRFLOW PERFORMANCE – 208 & 230 VOLTS

Nominal Cooling Capacity Tons [kW]	Blower Size/ Motor HP [W] & Motor Type	Nominal Heating Capacity Btu/hr [kW]	Motor Speed	External Static Pressure - Inches W.C. (kPa) (Side Discharge-Dry Coil)											
				0.1 [0.02]	0.2 [0.05]	0.3 [0.07]	0.4 [1.10]	0.5 [1.12]	0.6 [1.15]	0.7 [1.17]	0.8 [1.20]	0.9 [1.22]	1.0 [1.25]		
2.0 [17.03]	10 x 9 Blower 1/2 HP [1372 W] ECM	60,000 [117.58]	Heat	CFM [L/s]	1137 [1537]	1156 [1546]	1173 [1554]	1181 [1557]	1192 [1563]	1200 [1566]	1192 [1563]	1190 [1562]	1206 [1569]	1197 [1565]	
				RPM	755	868	929	994	1040	1098	1140	1212	1237	1278	
				Watts	177	236	270	307	336	376	404	456	477	508	
			Low Cool (1st Stage)	CFM [L/s]	548 [1259]	561 [1265]	561 [1265]	551 [1260]	556 [1262]	541 [1255]	530 [1250]	514 [1243]	492 [1232]	477 [1225]	477 [1225]
				RPM	488	596	685	762	835	891	955	1010	1051	1101	1101
				Watts	38	56	72	88	105	123	139	155	168	184	184
			High Cool (2nd Stage)	CFM [L/s]	786 [1371]	805 [1380]	811 [1383]	820 [1387]	825 [1389]	822 [1388]	826 [1390]	824 [1389]	816 [1385]	809 [1382]	809 [1382]
				RPM	573	695	751	838	908	969	1010	1082	1119	1171	1171
				Watts	72	103	120	148	175	199	218	248	265	290	290
			3.0 [110.55]	10 x 9 Blower 1/2 HP [1372 W] ECM	60,000 [117.58]	Heat	CFM [L/s]	1109 [1523]	1131 [1534]	1150 [1543]	1169 [1552]	1175 [1555]	1187 [1560]	1190 [1562]	1201 [1567]
RPM	687	706					855	912	961	1009	1057	1135	1152	1212	
Watts	147	157					226	254	287	317	347	397	413	456	
Low Cool (1st Stage)	CFM [L/s]	784 [1370]				801 [1378]	813 [1384]	820 [1387]	827 [1390]	830 [1392]	809 [1382]	806 [1380]	799 [1377]	791 [1373]	791 [1373]
	RPM	514				627	704	775	845	916	1014	1046	1097	1138	1138
	Watts	58				84	107	127	151	178	217	229	257	276	276
High Cool (2nd Stage)	CFM [L/s]	1124 [1530]				1144 [1540]	1167 [1551]	1183 [1558]	1197 [1565]	1204 [1568]	1205 [1569]	1237 [1584]	1231 [1581]	1230 [1580]	1230 [1580]
	RPM	697				766	866	923	975	997	1085	1110	1165	1211	1211
	Watts	152				185	234	268	298	314	372	391	428	463	463
4.0 [114.07]	10 x 9 Blower 3/4 HP [1559 W] ECM	80,000 [123.44] & 100,000 [129.3]				Heat	CFM [L/s]	1295 [1611]	1309 [1618]	1331 [1628]	1362 [1643]	1353 [1639]	1359 [1641]	1365 [1644]	1365 [1644]
			RPM	757	869		908	940	1014	1071	1105	1151	1199	1234	
			Watts	209	269		294	316	365	401	417	457	495	518	
			Low Cool (1st Stage)	CFM [L/s]	797 [1376]	804 [1379]	809 [1382]	810 [1382]	812 [1383]	785 [1370]	778 [1367]	766 [1362]	755 [1356]	737 [1348]	737 [1348]
				RPM	572	650	724	791	856	938	995	1049	1091	1138	1138
				Watts	77	94	116	133	155	184	203	226	243	264	264
			High Cool (2nd Stage)	CFM [L/s]	1185 [1559]	1199 [1566]	1211 [1572]	1229 [1580]	1241 [1586]	1242 [1586]	1254 [1592]	1241 [1586]	1238 [1584]	1236 [1583]	1236 [1583]
				RPM	730	798	857	930	995	1032	1099	1141	1173	1202	1202
				Watts	175	206	237	274	311	336	377	405	422	441	441
			4.0 [114.07]	10 x 9 Blower 3/4 HP [1559 W] ECM	80,000 [123.44] & 100,000 [129.3]	Heat	CFM [L/s]	1295 [1611]	1309 [1618]	1331 [1628]	1362 [1643]	1353 [1639]	1359 [1641]	1365 [1644]	1365 [1644]
RPM	757	869					908	940	1014	1071	1105	1151	1199	1234	
Watts	209	269					294	316	365	401	417	457	495	518	
Low Cool (1st Stage)	CFM [L/s]	1032 [1487]				1045 [1493]	1053 [1497]	1058 [1499]	1058 [1499]	1066 [1503]	1068 [1504]	1056 [1498]	1046 [1494]	1037 [1489]	1037 [1489]
	RPM	714				775	837	900	946	1006	1059	1087	1135	1187	1187
	Watts	137				160	186	214	235	267	293	309	335	362	362
High Cool (2nd Stage)	CFM [L/s]	1594 [1752]				1609 [1759]	1609 [1759]	1610 [1760]	1612 [1761]	1611 [1760]	1614 [1762]	1613 [1761]	1583 [1747]	1525 [1720]	1525 [1720]
	RPM	980				1044	1083	1130	1167	1202	1247	1281	1317	1326	1326
	Watts	396				445	477	516	549	580	618	652	665	665	665

Notes: All airflows listed (except the 5 ton high cool) can be adjusted by +/-10% using the dip switches on the ECM interface board located in the blower section. See ECM Motor Interface Control and Settings Section of before making adjustments. The +/-10% setting of the 5 ton high cool is not available to prevent water blow-off.

[] Designates Metric Conversions

INDOOR AIRFLOW PERFORMANCE — 208 & 230 VOLTS

Nominal Cooling Capacity Tons [kW]	Blower Size/ Motor HP [W] & Motor Type	Nominal Heating Capacity Btu/hr [kW]	Motor Speed	External Static Pressure - Inches W.C. [kPa] (Side Discharge-Dry Coil)										
				0.1 [.02]	0.2 [.05]	0.3 [.07]	0.4 [.10]	0.5 [.12]	0.6 [.15]	0.7 [.17]	0.8 [.20]	0.9 [.22]	1.0 [.25]	
5.0 117.59	12 x 9 Blower 1 HP [1746 W] ECM	100,000 [129.3]	Heat	CFM [L/s]	1295 [1611]	1300 [1614]	1322 [1624]	1325 [1625]	1344 [1634]	1343 [1634]	1343 [1634]	1351 [1638]	1349 [1637]	1349 [1637]
				RPM	640	751	814	846	890	935	971	1014	1046	1086
				Watts	189	254	299	326	356	393	423	460	484	525
			Low Cool (1st Stage)	CFM [L/s]	1258 [1594]	1280 [1604]	1279 [1604]	1297 [1612]	1306 [1616]	1310 [1618]	1312 [1619]	1312 [1619]	1313 [1620]	1320 [1623]
				RPM	649	674	795	846	883	939	956	999	1038	1069
				Watts	190	209	275	314	340	388	399	435	465	494
High Cool (2nd Stage)	CFM [L/s]	1871 [1883]	1871 [1883]	1866 [1881]	1886 [1890]	1908 [1900]	1875 [1885]	1921 [1907]	1907 [1900]	1906 [1900]	1909 [1901]			
	RPM	907	956	1016	1048	1084	1106	1151	1197	1209	1241			
			Watts	563	626	709	750	795	831	897	962	979	1030	

Notes: All airflows listed (except the 5 ton high cool) can be adjusted by +/-10% using the dip switches on the ECM interface board located in the blower section. See ECM Motor Interface Control and Settings Section of before making adjustments. The +10% setting of the 5 ton high cool is not available to prevent water blow-off.

DOWN DISCHARGE PRESSURE DROP (ADD TO EXTERNAL STATIC PRESSURE)			
CFM [L/s]	600 [283]	800 [378]	1000 [472]
Pressure Drop—Includes W.C. [kPa]	0	.02 [.005]	.05 [.012]
		.1 [.025]	.12 [.030]
		.15 [.037]	.17 [.042]

[] Designates Metric Conversions

ELECTRICAL DATA – RGEA16 SERIES

		024AJV***A*	036ACV***A*	036AJV***A*	048ACV***A*	048AJV***A*	060ACV***A*	060AJV***A*
Unit Information	Unit Operating Voltage Range	197-253	197-253	197-253	197-253	197-253	197-253	197-253
	Volts	208/230	208/230	208/230	208/230	208/230	208/230	208/230
	Phase	1	3	1	3	1	3	1
	Hz	60	60	60	60	60	60	60
	Minimum Circuit Ampacity	18	19	25	22	31	27	40
	Minimum Overcurrent Protection Device Size	20	20	30	25	40	30	45
	Maximum Overcurrent Protection Device Size	25	25	40	35	50	40	60
Compressor Motor	No.	1	1	1	1	1	1	1
	Volts	208/230	208/230	208/230	208/230	208/230	208/230	208/230
	Phase	1	3	1	3	1	3	1
	RPM	3450	3450	3450	3450	3450	3450	3450
	HP, Compressor 1	2 5/6	4	4	5 1/4	5 1/4	7	6 2/3
	Amps (RLA), Comp. 1	11.7	11.6	16.7	14	21.2	16.5	27.1
	Amps (LRA), Comp. 1	58.3	73	83	88	104	110	153
Condenser Motor	No.	1	1	1	1	1	1	1
	Volts	208/230	208/230	208/230	208/230	208/230	208/230	208/230
	Phase	1	1	1	1	1	1	1
	HP	1/6	1/6	1/6	1/3	1/3	1/3	1/3
	Amps (FLA, each)	0.6	0.6	0.6	1.5	1.5	2	2
	Amps (LRA, each)	1.5	1.5	1.5	3	3	3.9	3.9
Evaporator Fan	No.	1	1	1	1	1	1	1
	Volts	208/230	208/230	208/230	208/230	208/230	208/230	208/230
	Phase	1	1	1	1	1	1	1
	HP	1/2	1/2	1/2	3/4	3/4	1	1
	Amps (FLA, each)	2	2	2	3	3	4	4
	Amps (LRA, each)	—	—	—	—	—	—	—

1. Horsepower Per Compressor.
 2. Amp Draw Per Motor. Multiply Value By Number of Motors to Determine Total Amps.

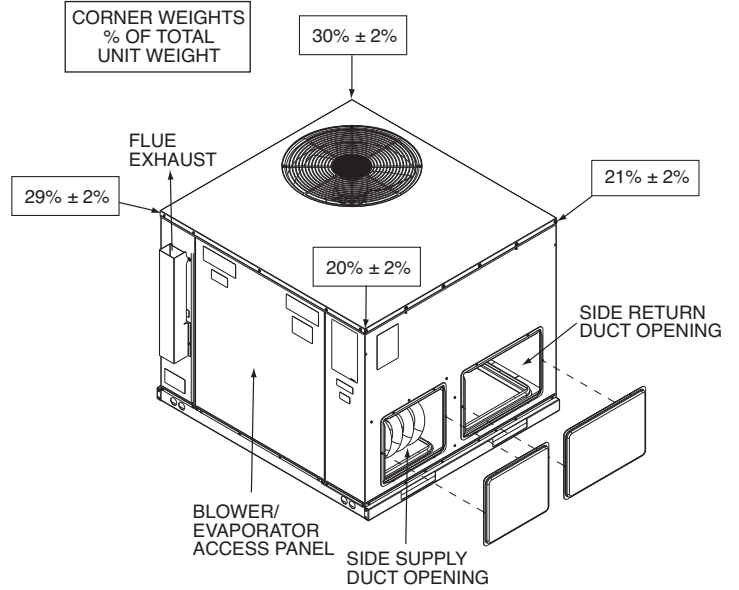
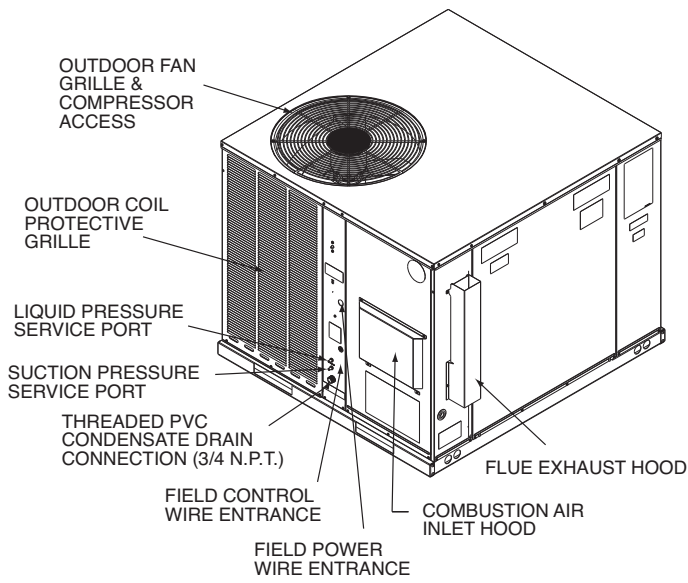

TOP VIEW

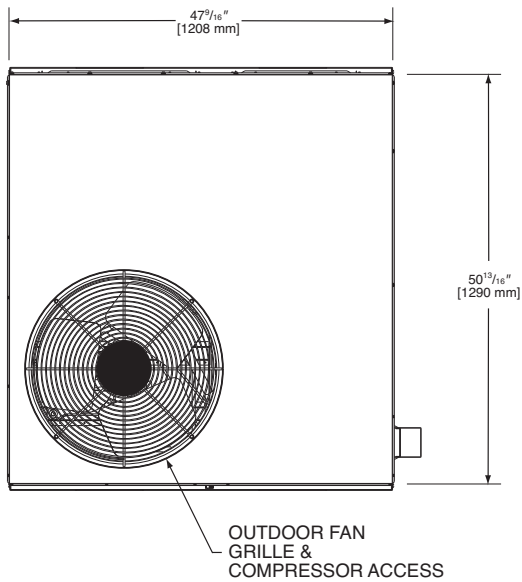

BOTTOM VIEW

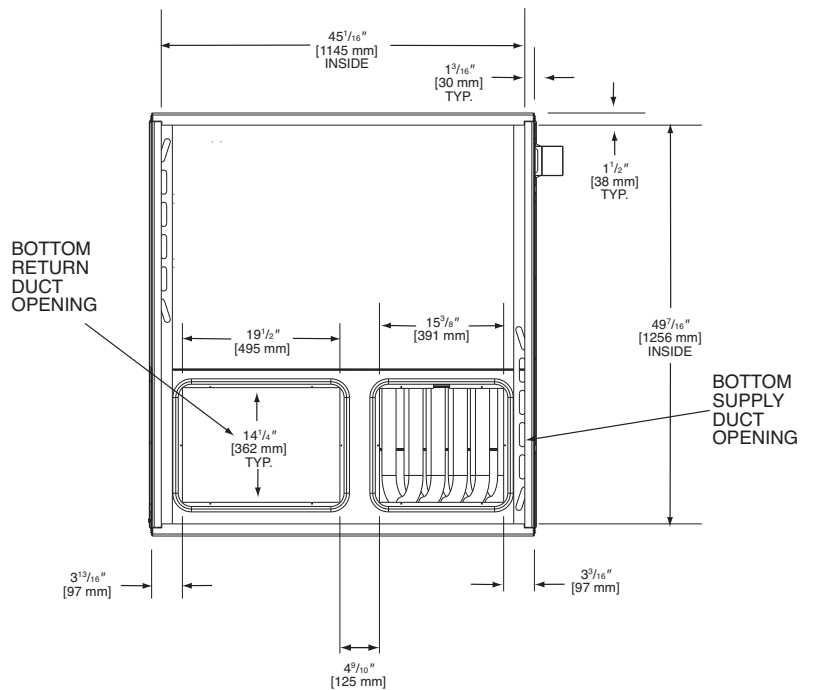

[] Designates Metric Conversions

SIDE VIEW

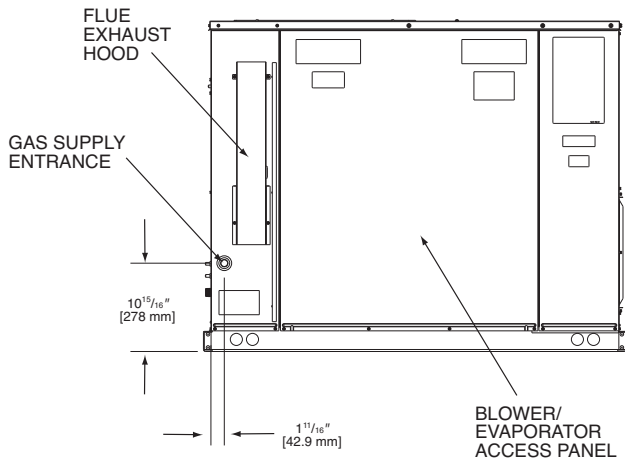

SIDE VIEW

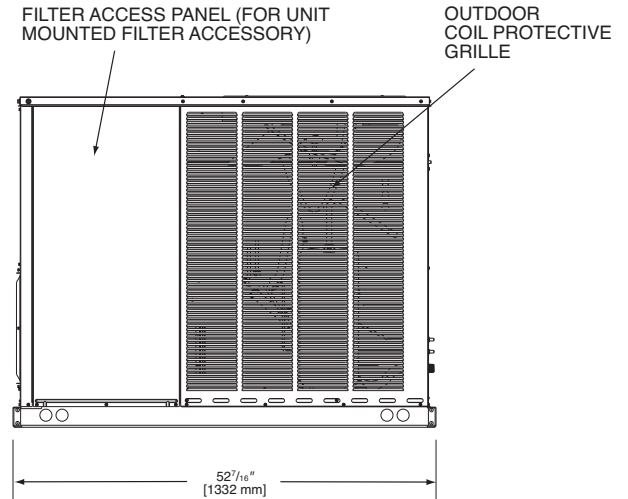

FRONT VIEW

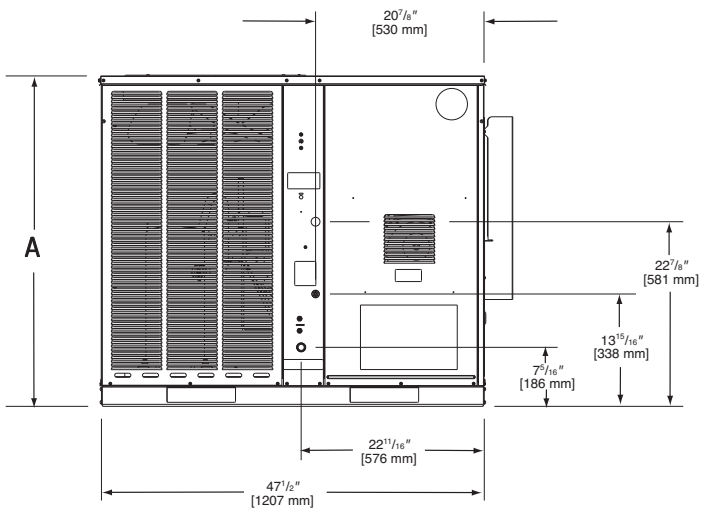

BACK VIEW

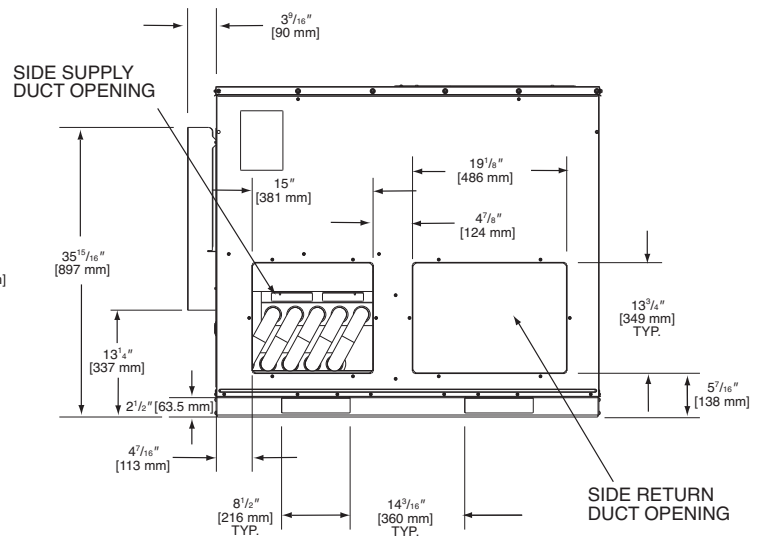

SHOWN WITH DUCT COVERS REMOVED.

Model: RGEA16	"A" Height
024	$35^{15}/16"$
036, 048, 060	41"

[] Designates Metric Conversions

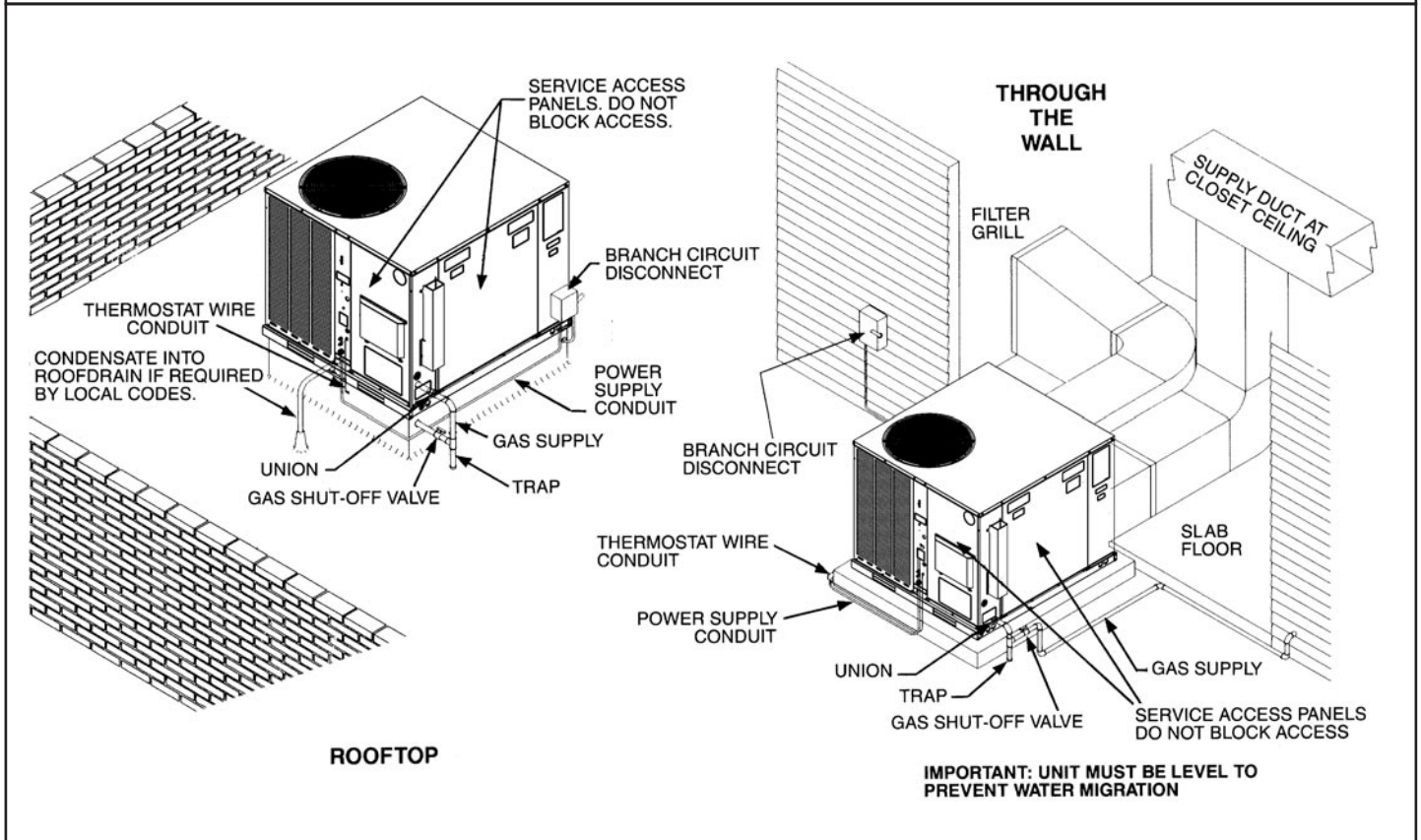
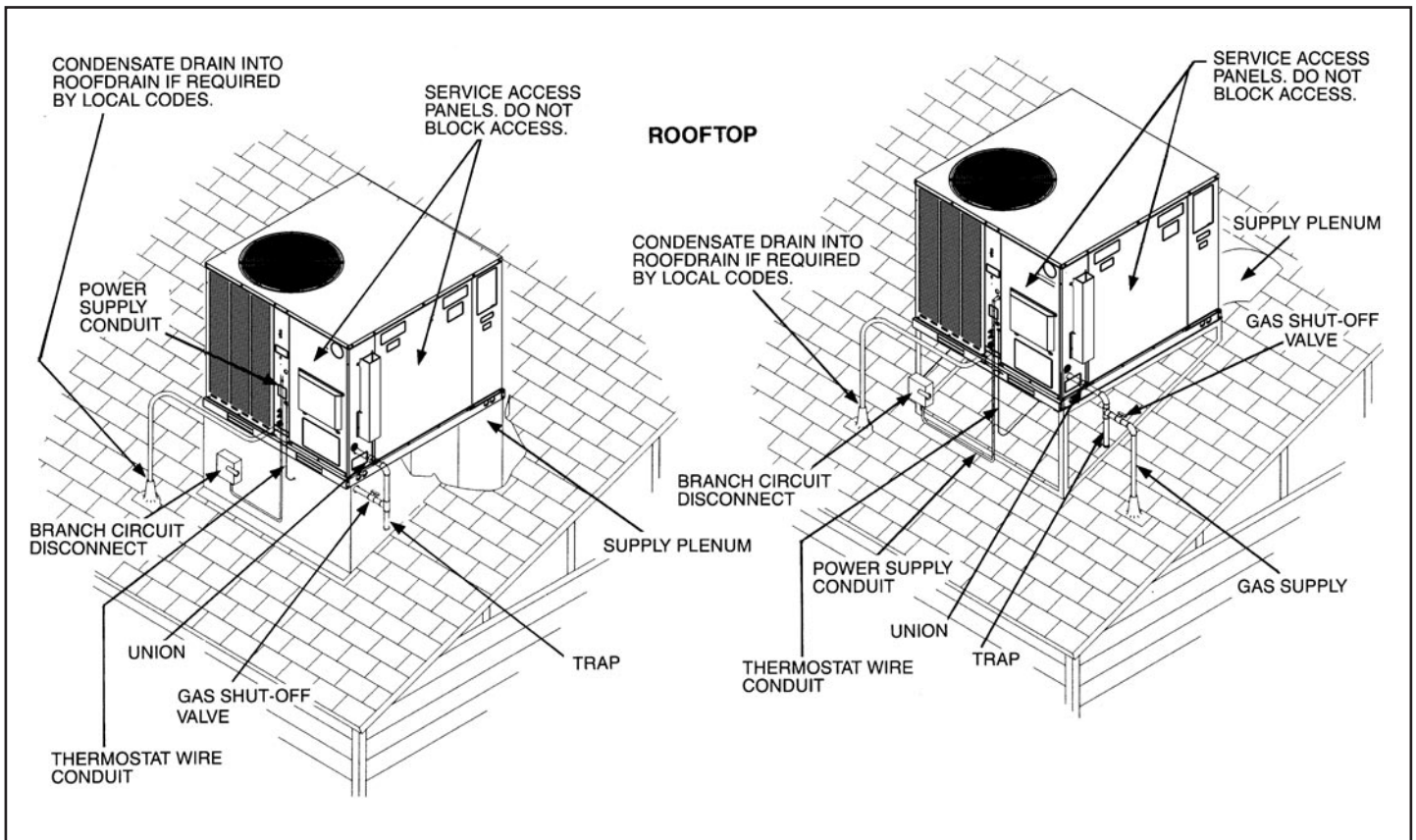

[] Designates Metric Conversions

ACCESSORY EQUIPMENT

Accessory Description	Model Application	Accessory Model No.
Roofcurbs	RGEA16	RXSG-AAA08 (8" [203 mm] Height) RXSG-AAA14 (14" [356 mm] Height) RXSG-AAA24 (24" [610 mm] Height)
Supply & Return Diffusers	RGEA16	RXRN-BD15
Economizers (Sideflow Only)	RGEA16	AXRD-CCM10 (Fully Modulating)
Economizers (Downflow Only)	RGEA16	AXRD-CAM10 (Fully Modulating)
Fresh Air Damper	RGEA16	AXRF-FAB1 (Motorized-35%) AXRF-FAA1 (Fixed-35%)
Rectangular to Round Transition (Downflow)	RGEA16	RXMC-CA02 (16" [406 mm] Ducts) RXMC-CA03 (18" [457 mm] Ducts)
Filter Kit	RGEA16	RXRY-B01
Sideflow Rectangular to Round Transition	RGEA16	AXMC-BA01
LP Conversion Kits	RGEA16	RXGJ-FP35
Low Ambient Control	RGEA16	RXRZ-B01
Canadian High Altitude Kit (for Natural Gas only ¹)	RGEA16	RXRZ-AH01
Dehumidistat	RGEA16	41-25066-02 (Available through PROSTOCK)

¹ If a particular unit is to be converted to operate on LP (propane) for elevations above 2000 ft. [609.6 m] in Canada, the existing Natural Gas to LP Conversion Kits for the subject models already contain the necessary orifices and instructions to de-rate the input for 2000-4500 ft. [609.6-1371.6 m] Canadian applications.

² High and low pressure switches are standard for RGEA16 Models.

[] Designates Metric Conversions

COMMON SUPPLY/RETURN CONCENTRIC AIR DIFFUSER

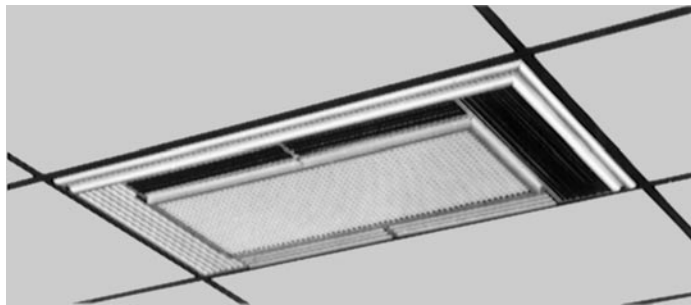

SUPPLY/RETURN DIFFUSER

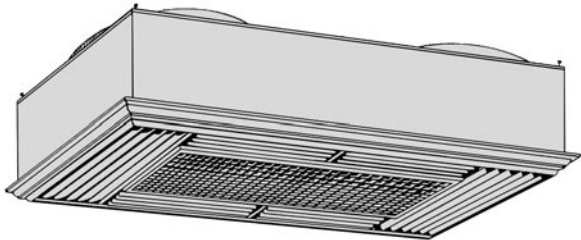

Designed to convert a side by side or an over and under arrangement into a concentric distribution of air. The diffuser is flush mounted, completely insulated, assembled, and internally baffled to provide four way supply air distribution with a center return. To make the assembly complete and ready to fit into a 2' [0.61 m] x 4' [1.22 m] suspended ceiling grid, the diffuser includes adjustable supply louvers, hanging rings, anti-sweat gasket, and round flanges for use with flexible ducts.

Model No.	Diameter Inches [mm]	Shipping Wt. Lbs. [kg]	Dimension A Inches [mm]
RXRN-BD15	16 [406]	90 [40.82]	20 1/2 [521]

DIFFUSER INSTALLS FLUSH WITH CEILING

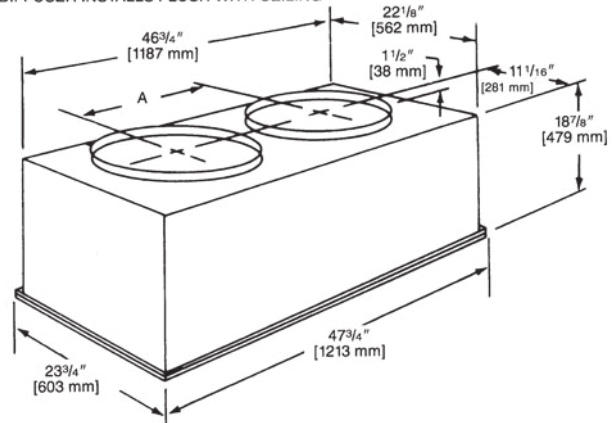

NOTE: The location of the combination supply and return diffuser should not exceed 10 feet [3.05 m] above the floor level for units @ 1000 CFM [472 L/s] or less and 12 [3.66 m] to 14 feet [4.27 m] above the floor level for units with CFM greater than 1000 [472 L/s]. If the diffuser is installed with a greater distance than recommended above, the supply air may become stratified above the required comfort area causing uncomfortable conditions.

AIRFLOW/PRESSURE DROP INFORMATION (INCHES W.C. [kPa])

Accessory	Approximate CFM [L/s]-Supply Air			
	1300 [614]	1575 [743]	1800 [850]	2200 [1038]
Plenum & Supply/Return Duct	.07 [.017]	.10 [.024]	.12 [.030]	.17 [.042]
Diffuser	.09 [.022]	.13 [.032]	.16 [.040]	.24 [.060]
Economizer	.06 [.015]	.09 [.022]	.11 [.027]	.17 [.042]

SUPPLY AIR/PERFORMANCE

Diffuser Airflow CFM [L/s]	Range of Throw Ft. [m]
800 [378]-1200 [566]	14 [4.27]-16 [4.88]
1600 [755]-2000 [944]	18 [5.49]-28 [8.53]

DUCT ADAPTERS RECTANGULAR TO ROUND TRANSITIONS (DOWNFLOW)

RXMC-CA02

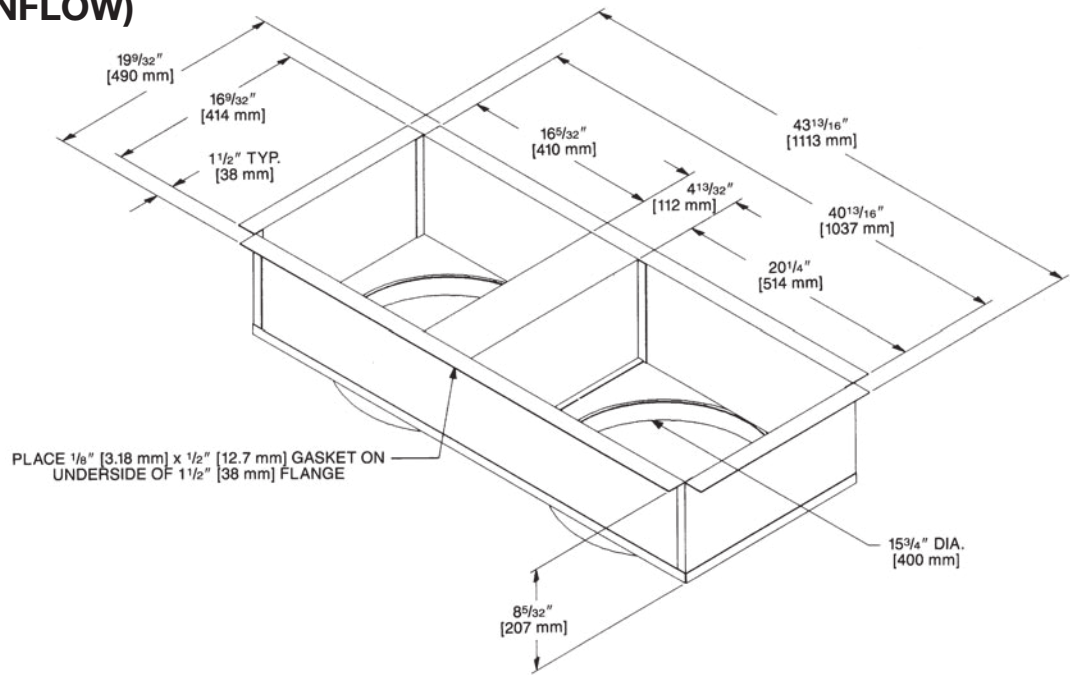

RXMC-CA03

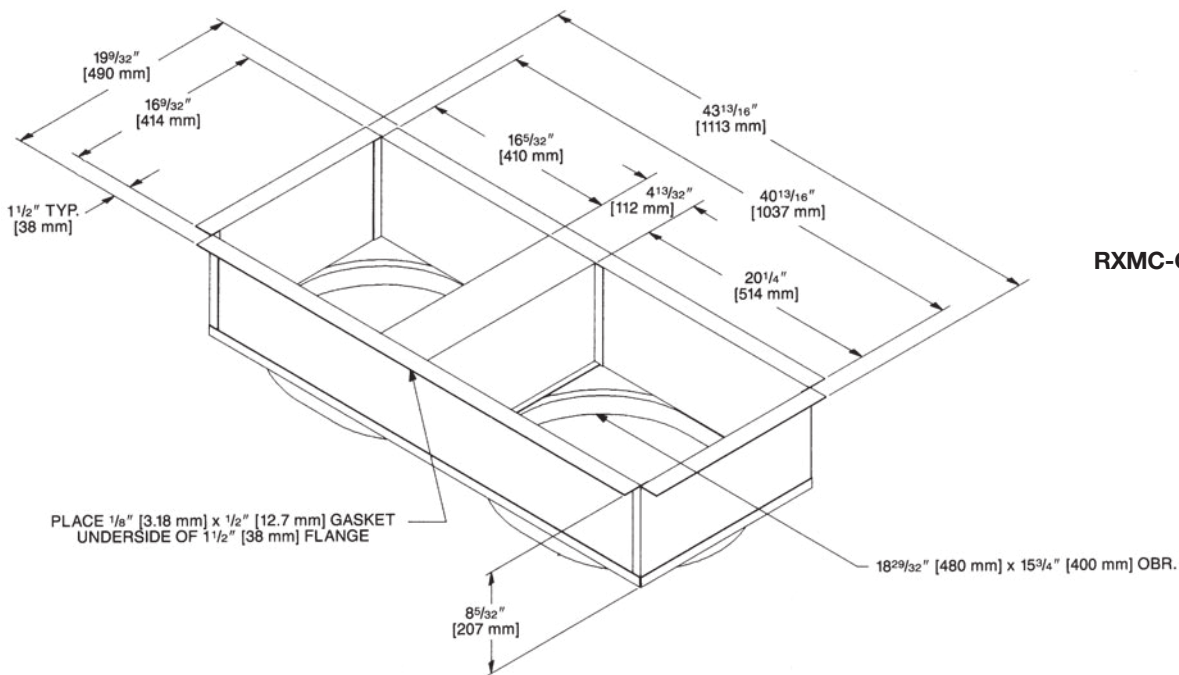

[] Designates Metric Conversions

FRESH AIR DAMPER

AXRF-FAA1 (Fixed - 0-35%)

The 0-35% manual outside Air Damper is designed to replace the unit return air duct cover. No drilling or damper assembly is required. The amount of outside air (0-35%) is controlled by simply adjusting the side damper.

AXRF-FAB1 (Motorized - 0-35%)

The 0-35% motorized outside Air Damper is designed to replace the unit return air duct cover. No drilling or damper assembly is required. The control motor opens the adjustable slide damper when the unit blower motor is energized.

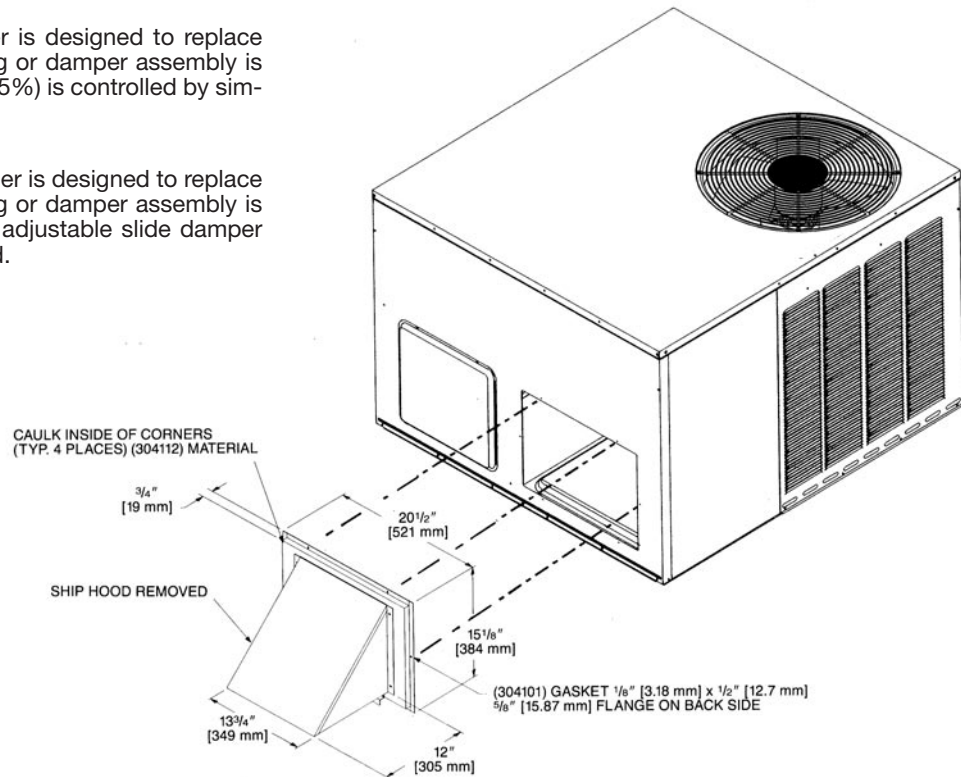

ECONOMIZERS

AXRD-CAM10 (Fully Modulating)

AXRD-CAM10 (Fully Modulating)

Provided with enthalpy control, mixed air sensor and minimum position potentiometer for proportioning (modulating) the amount of fresh air.

NOTE: See economizer installation instructions for correct filter access door.

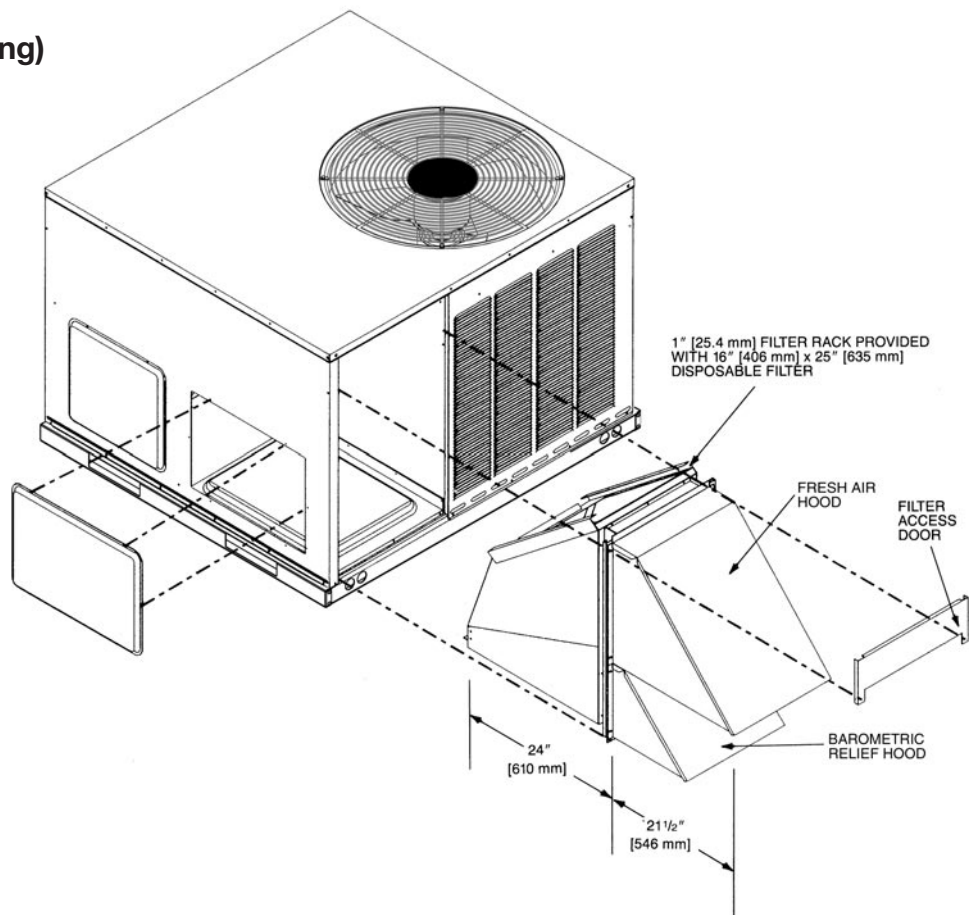

[] Designates Metric Conversions

ECONOMIZERS

AXRD-CCM10 (Fully Modulating) Horizontal Application

AXRD-CCM10 (Fully Modulating)

Provided with enthalpy control, mixed air sensor and minimum position potentiometer for proportioning (modulating) the amount of fresh air.

[] Designates Metric Conversions

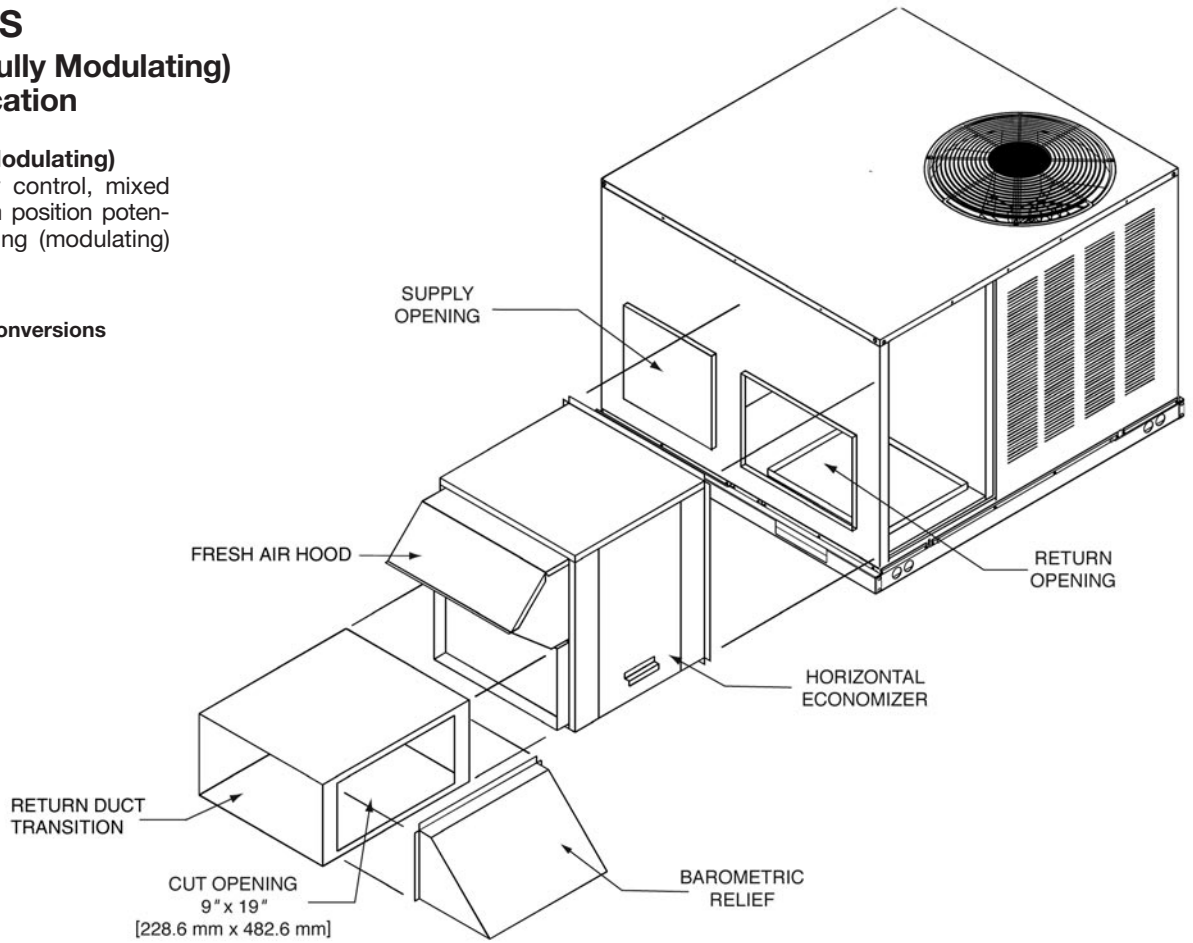

FILTER KIT INSTALLATION RXRY-B01

For use in either
vertical or horizontal
discharge.

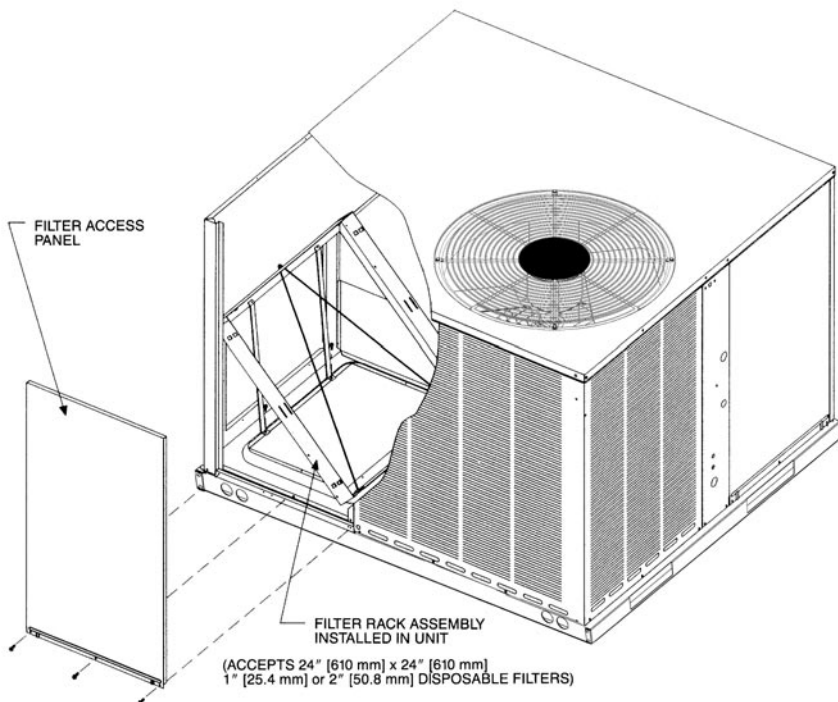

Airflow Pressure Drop, Inches W.C. [kPa]		
CFM [L/s]	1" Filter	2" Filter
500 [236]	.02 [.0050]	.03 [.0075]
600 [283]	.02 [.0050]	.03 [.0075]
700 [330]	.03 [.0075]	.04 [.0010]
800 [378]	.04 [.0010]	.05 [.0124]
900 [425]	.05 [.0124]	.06 [.0149]
1000 [472]	.07 [.0174]	.08 [.0199]
1100 [519]	.08 [.0199]	.09 [.0224]
1200 [566]	.10 [.0249]	.12 [.0299]
1300 [614]	.13 [.0324]	.15 [.0373]
1400 [661]	.16 [.0398]	.19 [.0473]
1500 [708]	.19 [.0473]	.21 [.0523]
1600 [755]	.20 [.0498]	.23 [.0572]
1700 [802]	.21 [.0523]	.24 [.0598]
1800 [850]	.22 [.0548]	.25 [.0623]
1900 [897]	.24 [.0598]	.27 [.0672]
2000 [944]	.26 [.0647]	.29 [.0722]

[] Designates Metric Conversions

DUCT ADAPTER SIDEFLOW SQUARE TO ROUND TRANSITION AXMC-BA01

Adapts the side rectangular supply and return openings to 14" [356 mm] diameter round openings. Adapters provided with same finish as unit and also provided with thermal insulation.

[] Designates Metric Conversions

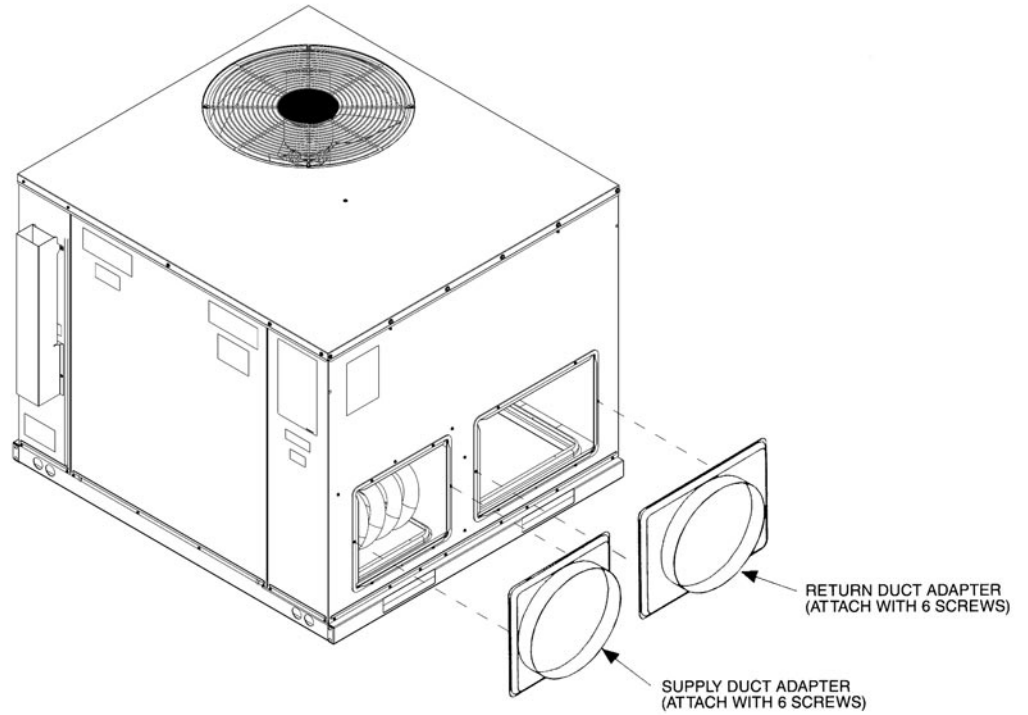

ROOFCURB (Full Perimeter)
RXSG-AAA08, RXSG-AAA14
and RXSG-AAA24

Hinged corners make for fast, easy set-up.

RXSG-AAA08
(8" [203 mm] High)

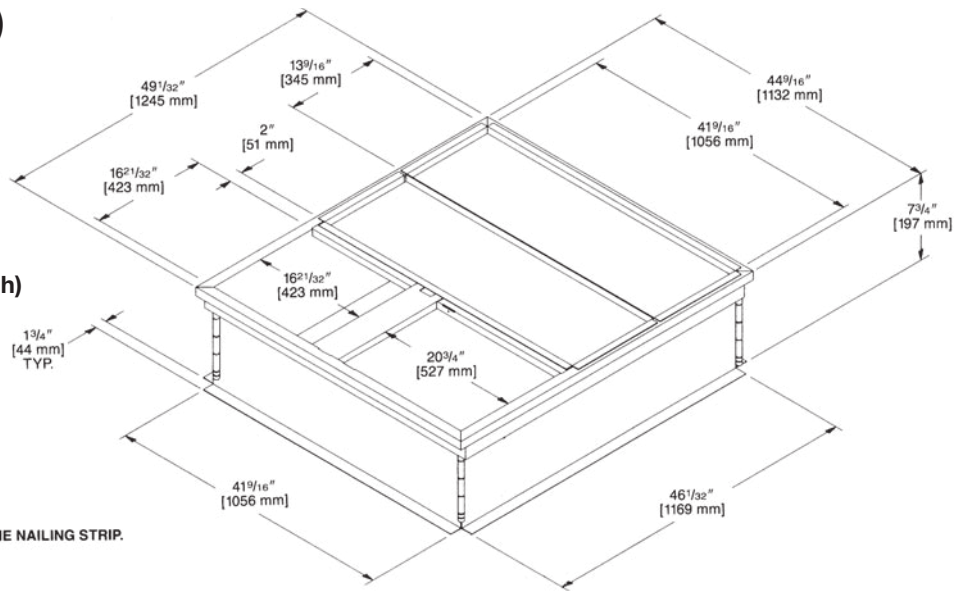

NOTE: PERIMETER OF ROOFCURB IS SUPPLIED WITH A NOMINAL 1" [25.4 mm] x 4" [102 mm] PINE NAILING STRIP.

RXSG-AAA14
(14" [356 mm] High)

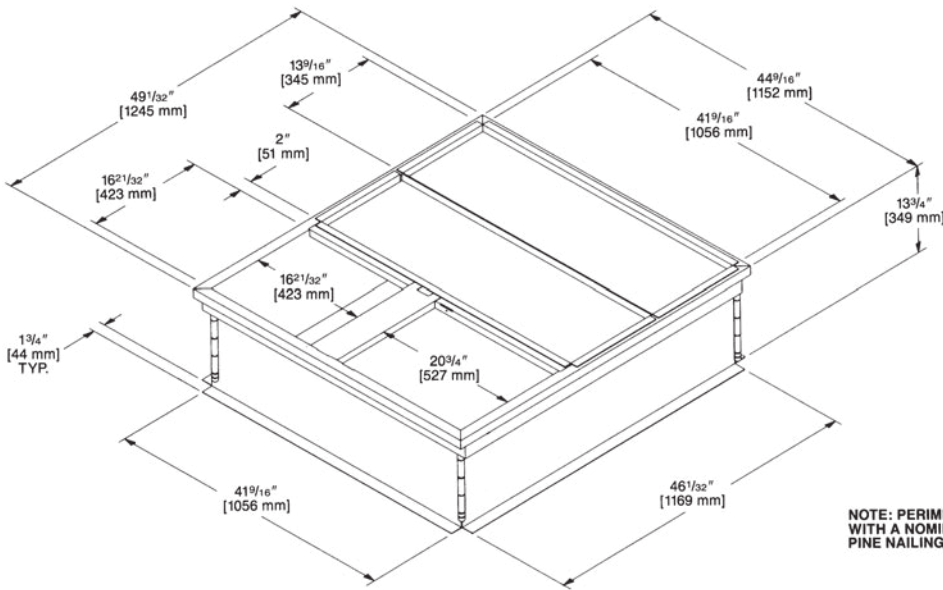

NOTE: PERIMETER OF ROOFCURB IS SUPPLIED WITH A NOMINAL 1" [25.4 mm] x 4" [102 mm] PINE NAILING STRIP.

RXSG-AAA24
(24" [610 mm] High)

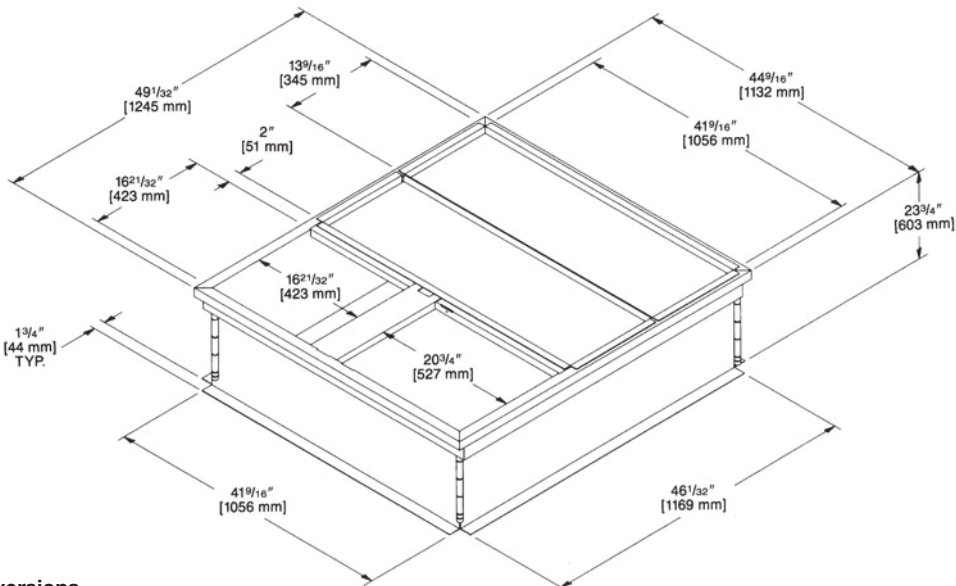

[] Designates Metric Conversions

PACKAGE AIR CONDITIONERS & PACKAGE GAS/ELECTRIC UNITS ROOFCURB INSTALLATION (Full Perimeter)

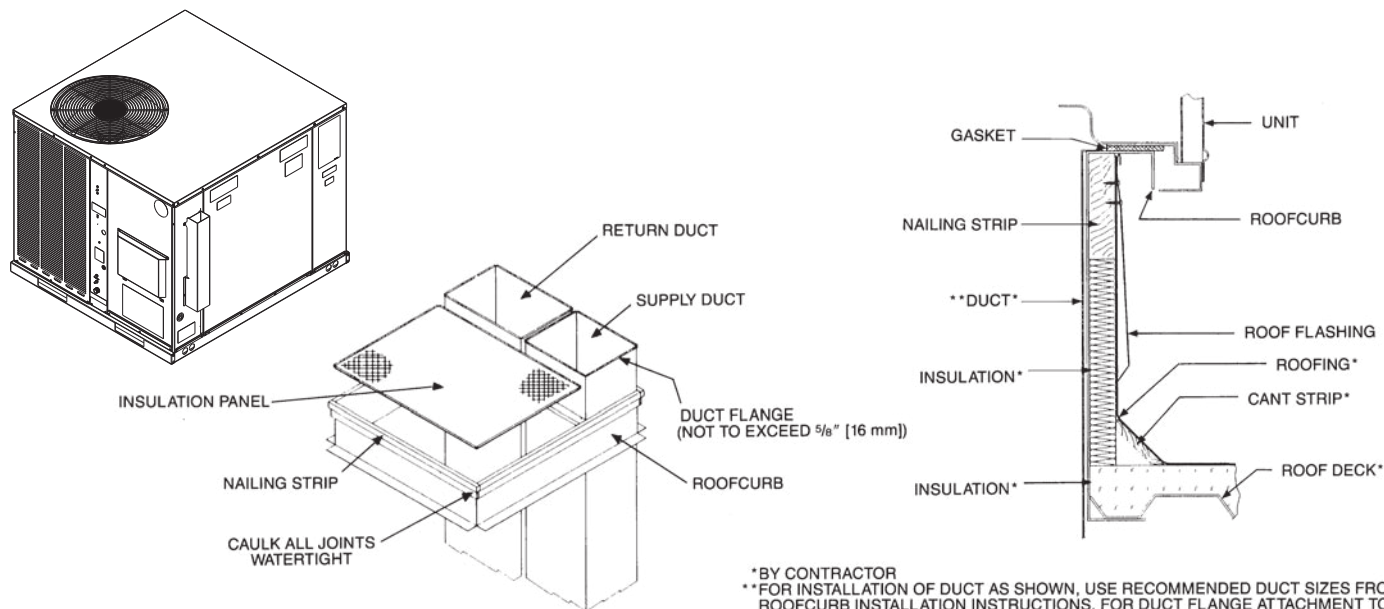

*BY CONTRACTOR
 **FOR INSTALLATION OF DUCT AS SHOWN, USE RECOMMENDED DUCT SIZES FROM ROOFCURB INSTALLATION INSTRUCTIONS. FOR DUCT FLANGE AT ATTACHMENT TO UNIT, SEE UNIT INSTALLATION INSTRUCTIONS FOR RECOMMENDED DUCT SIZES.

ROOFCURB ADAPTERS

Fabricated from galvanized steel to adapt the New cabinet to the old style curb. All are furnished with a New gasket.

OLD MODEL

SMALL CABINET
 (1½-2 TON) [5.28-7.03 kW]
 RSNC-, RSND-, RSNE-
 RRGE-, RRGF-, RRGG-, RSNY

MEDIUM CABINET
 (2½-3 TON) [8.79-10.55 kW]
 RSNC-, RSND-, RSNE-
 RRGE-, RRGF-, RRGG-, RSNY

LARGE CABINET
 (3-3½ TON) [10.55-12.31 kW]
 RRGE-, RRGF-, RRGG-, RSNY

EXTRA LARGE CABINET
 (3½-5 TON) [12.31-17.6 kW]
 RSNC-, RSND-, RSNE-
 RRGE-, RRGF-, RRGG-, RSNY
 (4-5 TON) [14.07-17.58 kW]
 (1) SLOPE TYPE
 (2) FULL PERIMETER TYPE

OLD CURB MODEL

NEW MODEL TO OLD MODEL ROOFCURB ADAPTER

NEW MODEL PACKAGE

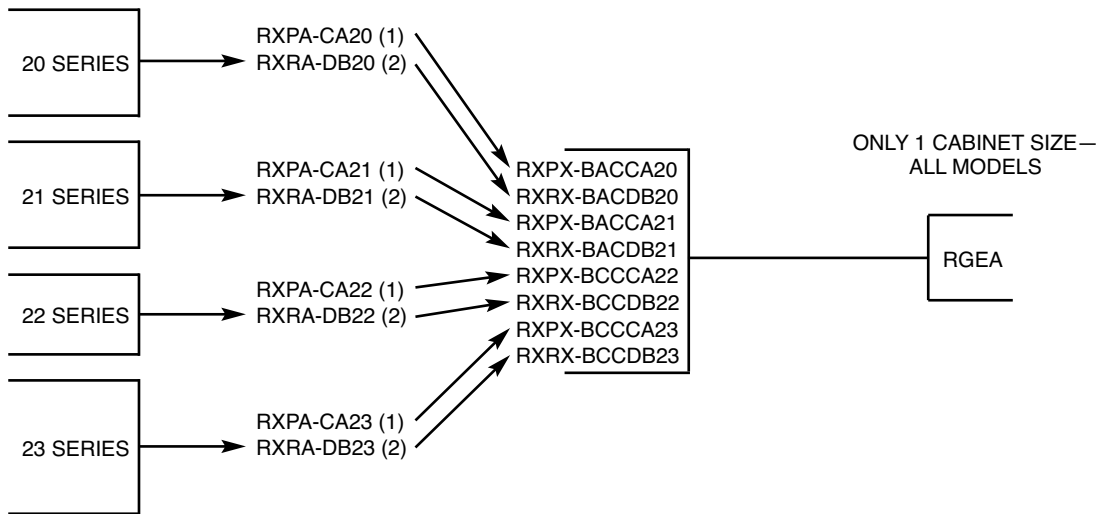

[] Designates Metric Conversions

BEFORE PURCHASING THIS APPLIANCE, READ IMPORTANT ENERGY COST AND EFFICIENCY INFORMATION AVAILABLE FROM YOUR RETAILER.

GENERAL TERMS OF LIMITED WARRANTY*

Rheem® will furnish a replacement for any part of this product which fails in normal use and service within the applicable periods stated, in accordance with the terms of the limited warranty.

Heat Exchanger

- Factory StandardTen (10) Years
- Stainless Steel/1-Phase & 3-Phase Models
- Commercial ApplicationTwenty (20) Years
- Stainless Steel/1-Phase Models
- Residential Application.....Limited Lifetime

Compressor

- 1 Phase, Residential Applications.....Ten (10) Years
- 1 & 3 Phase, Commercial ApplicationsFive (5) Years

Parts

- 1 Phase, Residential ApplicationsTen (10) Years
- 1 & 3 Phase, Commercial ApplicationsOne (1) Year

*For complete details of the Limited and Conditional Warranties, including applicable terms and conditions, contact your local contractor or the Manufacturer for a copy of the product warranty certificate.



Russell™ By Rheem

5600 Old Greenwood Road, Fort Smith, AR 72908

Before proceeding with installation, refer to installation instructions packaged with each model, as well as complying with all Federal, State, Provincial, and Local codes, regulations, and practices.