

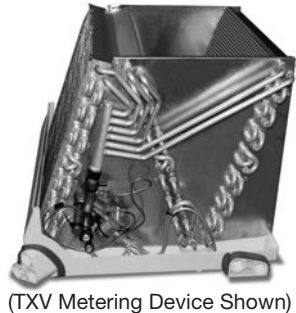

# MODEL: TCF Cased/Uncased Coils For Gas And Oil Furnaces

FORM NO. CSC-224 REV. 2



(TXV Metering Device Shown)



## Sure Comfort® TCF Cased/Uncased Coils For Gas And Oil Furnaces

- Featuring Industry Standard R-410A Refrigerant
- Airflow Capacity  
600-1,900 CFM [283-897 L/s]



- Sure Comfort® Indoor Furnace cased coils and replacement uncased coils are designed for use with Sure Comfort outdoor units and are available for vertical upflow or downflow, and horizontal left or horizontal right airflow. When matched with Sure Comfort outdoor units, the coils provide a nominal capacity range from 18,000 BTU/HR [5.24 kW] to 60,000 BTU/HR [17.6 kW].
- Constructed of aluminum fins bonded to internally grooved aluminum tubing.
- Coils are tested at the factory with an extensive refrigerant leak check.
- Coils have copper sweat refrigerant connections.
- Feature two sets of 3/4" [14.1 mm] N.P.T. Condensate drain connections for ease of connection.
- Chatleff metering device connections, at inlet and outlet of TXV or EEV and equalizer connections (TXV only).
- Approved for system application with variety of Sure Comfort outdoor units.
- Condensate drain pan is constructed of high grade, heat resistant, corrosion free thermal-set material.
- Compatible with Germicidal Light System (UV resistant)
- Bi-Directional airflow eliminates the need to switch any internal components from horizontal left to right.
- Unique drain pan design maximizes application flexibility and condensate removal.
- N-Coil design maximizes performance and minimizes height required at installation.
- Coils are AHRI certified for system application with a variety of Sure Comfort outdoor units.

## Table of Contents

Model Number Identification .....	3
Coil Specifications .....	4-5
Coil Dimensions and Weights.....	6-7
Accessories .....	8-9
Limited Warranty .....	10

## Model Number Identification

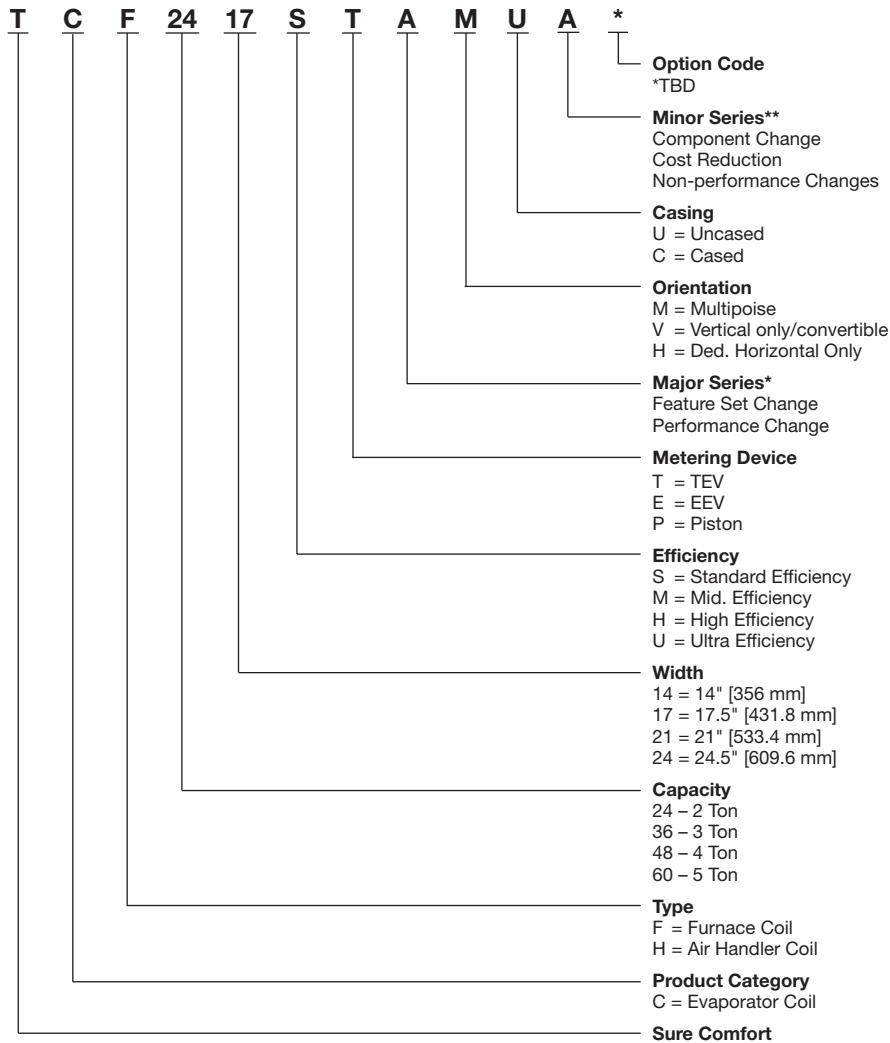

[ ] Designates Metric Conversions

TXV MODELS AVAILABLE	
TCF2414STAMCA	TCF2414STAVUA
TCF2417STAMCA	TCF2417STAVUA
TCF2417MTAMCA	TCF2417MTAVUA
TCF2417HTAMCA	TCF2417HTAVUA
TCF2421MTAMCA	TCF2421MTAVUA
TCF2421HTAMCA	TCF2421HTAVUA
TCF3617STAMCA	TCF3617STAVUA
TCF3621STAMCA	TCF3621STAVUA
*TCF3621MTAMCA	*TCF3621MTAVUA
TCF3621HTAMCA	TCF3621HTAVUA
TCF3624MTAMCA	TCF3624MTAVUA
TCF3624HTAMCA	TCF3624HTAVUA
TCF4821STAMCA	TCF4821STAVUA
*TCF4821MTAMCA	*TCF4821MTAVUA
TCF4824STAMCA	TCF4824STAVUA
TCF4824HTAMCA	TCF4824HTAVUA
*TCF6021STAMCA	*TCF6021STAVUA
*TCF6021MTAMCA	*TCF6021MTAVUA
TCF6024STAMCA	TCF6024STAVUA
TCF6024HTAMCA	TCF6024HTAVUA

EEV MODELS AVAILABLE	
TCF2417SEAMCA	TCF2417SEAVUA
TCF2421MEAMCA	TCF2421MEAVUA
*TCF2421UEAMCA	*TCF2421UEAVUA
TCF3617SEAMCA	TCF3617SEAVUA
TCF3621MEAMCA	TCF3621MEAVUA
*TCF6021SEAMCA	*TCF6021SEAVUA
TCF6024MEAMCA	TCF6024MEAVUA

PISTON MODELS AVAILABLE	
TCF2417SPAMCA	TCF2417SPAVUA
TCF3617SPAMCA	TCF3617SPAVUA
TCF3621SPAMCA	TCF3621SPAVUA
TCF4821SPAMCA	TCF4821SPAVUA
TCF4824SPAMCA	TCF4824SPAVUA

\*Denotes A Coil

**Table 1: Coil Specifications/Airflow Pressure Drop**

Coil Model (-)CF	Approx. Design Cooling Air Flow Range CFM [L/s]	Face Area Sq. Ft. [m <sup>2</sup> ]	Fins Per Inch / Rows Deep	Width	Nominal Capacity	Wet Coil Static Pressure Drop (Inches W.C.) [kPa] @ CFM [L/s] – (Coil Only)															
						600 [283]	700 [330]	800 [378]	900 [425]	1000 [472]	1100 [519]	1200 [566]	1300 [614]	1400 [661]	1500 [708]	1600 [755]	1700 [802]	1800 [850]	1900 [897]		
TCF2414STAM	600/900 [283/425]	4.56 [0.42]	16/2	14	1.5 – 2	0.165	0.209	0.262	0.325	—	—	—	—	—	—	—	—	—	—		
TCF2417STAM TCF2417SEAM	600/900 [283/425]	4.56 [0.42]	16/2	17		0.120	0.157	0.199	0.246	—	—	—	—	—	—	—	—	—	—	—	
TCF2417MTAM	600/900 [283/425]	5.70 [0.52]	16/2			0.113	0.145	0.181	0.222	—	—	—	—	—	—	—	—	—	—	—	—
TCF3617STAM TCF3617SEAM	700/1300 [330/614]	5.70 [0.52]	16/2	21	2.5 – 3	0.113	0.145	0.181	0.222	0.266	0.315	0.368	—	—	—	—	—	—	—	—	
TCF2421MTAM TCF2421MEAM	600/900 [283/425]	5.70 [0.52]	16/2		1.5 – 2	0.113	0.145	0.181	0.222	—	—	—	—	—	—	—	—	—	—	—	—
TCF3621STAM	700/1300 [330/614]	5.70 [0.52]	16/2		2.5 – 3	0.113	0.145	0.181	0.222	0.266	0.315	0.368	—	—	—	—	—	—	—	—	—
TCF3621MTAM TCF3621MEAM	700/1300 [330/614]	8.55 [0.79]	16/2			0.062	0.086	0.112	0.140	0.170	0.202	0.236	—	—	—	—	—	—	—	—	—
TCF3621HTAM	700/1300 [330/614]	7.60 [0.70]	13/3			0.106	0.125	0.146	0.169	0.194	0.221	0.251	—	—	—	—	—	—	—	—	—
TCF4821MTAM	1100/1800 [519/850]	7.60 [0.70]	13/3		3.5 – 4	0.106	0.125	0.146	0.169	0.194	0.221	0.251	0.282	0.315	0.350	0.386	0.425	0.466	—	—	—
TCF4821STAM	1100/1800 [519/850]	8.55 [0.79]	16/2			0.062	0.086	0.112	0.140	0.170	0.202	0.236	0.272	0.309	0.349	0.391	0.434	0.480	0.527	—	—
TCF6021STAM TCF6021SEAM TCF6021MTAM TCF2421UEAM	1400/1600 [661/755]	7.60 [0.70]	13/3		2 – 5	0.036	0.050	0.065	0.081	0.098	0.117	0.137	0.158	0.180	0.203	0.228	0.254	—	—	—	—
TCF3624MTAM	700/1300 [330/614]	8.55 [0.79]	16/2		24	2.5 – 3	0.062	0.086	0.112	0.140	0.170	0.202	0.236	0.272	0.309	—	—	—	—	—	—
TCF3624HTAM	700/1300 [330/614]	9.98 [0.93]	14/3				0.036	0.050	0.065	0.081	0.098	0.117	0.137	0.158	0.180	—	—	—	—	—	—
TCF4824STAM	1100/1800 [519/850]	8.55 [0.79]	16/2	3.5 – 4		0.062	0.086	0.112	0.140	0.170	0.202	0.236	0.272	0.309	0.349	0.391	0.434	0.480	—	—	
TCF4824HTAM	1100/1800 [519/850]	9.98 [0.93]	14/3			0.036	0.050	0.065	0.081	0.098	0.117	0.137	0.158	0.180	0.203	0.228	0.254	0.281	—	—	
TCF6024STAM TCF6024MEAM	1400/1800 [661/755]	9.98 [0.93]	14/3	5		0.036	0.050	0.065	0.081	0.098	0.117	0.137	0.158	0.180	0.203	0.228	0.254	0.281	—	—	
TCF6024HTAM	1400/1800 [661/755]	9.98 [0.93]	14/3			0.036	0.050	0.065	0.081	0.098	0.117	0.137	0.158	0.180	0.203	0.228	0.254	0.281	—	—	

**Important Note:** Gas furnace heating CFM can exceed the design cooling CFM. Ductwork and coil selection must accommodate the higher of the cooling or gas heating CFM to prevent furnace limit tripping, excessive noise, and coil freeze-up.

[ ] Designates Metric Conversions

**Table 1: Coil Specifications/Airflow Pressure Drop (con't.)**

Coil Model (-)CF	Approx. Design Heating Air Flow Range CFM [L/s]	Face Area Sq. Ft. [m <sup>2</sup> ]	Fins Per Inch / Rows Deep	Width	Nominal Capacity	Dry Coil Static Pressure Drop (Inches W.C.) [kPa] @ CFM [L/s] – (Coil-Only)															
						600 [283]	700 [330]	800 [378]	900 [425]	1000 [472]	1100 [519]	1200 [566]	1300 [614]	1400 [661]	1500 [708]	1600 [755]	1700 [802]	1800 [850]	1900 [897]		
TCF2414STAM	600/1600 [283/755]	4.56 [0.42]	16/2	14	1.5 – 2	0.118	0.118	0.145	0.176	0.210	0.247	0.288	0.332	0.379	0.429	0.483	—	—	—		
TCF2417STAM TCF2417SEAM	600/1500 [283/707]	4.56 [0.42]	16/2	17		0.116	0.116	0.151	0.190	0.235	0.284	0.338	0.397	0.461	0.530	—	—	—	—		
TCF2417MTAM	600/1600 [283/755]	5.70 [0.52]	16/2			0.101	0.101	0.129	0.161	0.196	0.235	0.277	0.323	0.373	0.425	0.482	—	—	—	—	
TCF3617STAM TCF3617SEAM	600/1600 [283/755]	5.70 [0.52]	16/2		2.5 – 3	0.101	0.101	0.129	0.161	0.196	0.235	0.277	0.323	0.373	0.425	0.482	—	—	—		
TCF2421MTAM	600/1600 [283/755]	5.70 [0.52]	16/2	21	1.5 – 2	0.101	0.101	0.129	0.161	0.196	0.235	0.277	0.323	0.373	0.425	0.482	—	—	—		
TCF2422HTAM TCF2421MEAM	600/1600 [283/755]	5.70 [0.52]	16/2			0.101	0.101	0.129	0.161	0.196	0.235	0.277	0.323	0.373	0.425	0.482	—	—	—	—	
TCF3621STAM	600/1600 [283/755]	5.70 [0.52]	16/2		2.5 – 3	0.101	0.101	0.129	0.161	0.196	0.235	0.277	0.323	0.373	0.425	0.482	—	—	—	—	
TCF3621MTAM	600/1900 [283/896]	8.55 [0.79]	16/2			0.039	0.039	0.056	0.075	0.095	0.117	0.141	0.166	0.193	0.222	0.252	0.284	0.318	0.353	—	
TCF3621HTAM TCF3621MEAM	600/1900 [283/896]	7.60 [0.70]	13/3			0.043	0.043	0.053	0.066	0.080	0.096	0.115	0.135	0.158	0.182	0.208	0.237	0.267	0.299	—	
TCF4821MTAM	600/1900 [283/896]	7.60 [0.70]	13/3		3.5 – 4	0.043	0.043	0.053	0.066	0.080	0.096	0.115	0.135	0.158	0.182	0.208	0.237	0.267	0.299	—	
TCF4821STAM	600/1900 [283/896]	8.55 [0.79]	16/2			0.039	0.039	0.056	0.075	0.095	0.117	0.141	0.166	0.193	0.222	0.252	0.284	0.318	0.353	—	
TCF6021STAM TCF6021SEAM TCF6021MTAM TCF2421UEAM	600/1900 [283/896]	7.60 [0.70]	13/3		2 – 5	0.080	0.080	0.092	0.106	0.121	0.136	0.153	0.171	0.190	0.211	0.232	0.254	0.278	0.302	—	
TCF3624MTAM	600/1900 [283/896]	8.55 [0.79]	16/2		24	2.5 – 3	0.039	0.039	0.056	0.075	0.095	0.117	0.141	0.166	0.193	0.222	0.252	0.284	0.318	0.353	—
TCF3624HTAM	600/1900 [283/896]	9.98 [0.93]	14/3				0.023	0.023	0.038	0.055	0.074	0.095	0.119	0.144	0.171	0.200	0.231	0.264	0.300	0.337	—
TCF4824STAM	600/1900 [283/896]	8.55 [0.79]	16/2	3.5 – 4		0.039	0.039	0.056	0.075	0.095	0.117	0.141	0.166	0.193	0.222	0.252	0.284	0.318	0.353	—	
TCF4824HTAM	600/1900 [283/896]	9.98 [0.93]	14/3			0.023	0.023	0.038	0.055	0.074	0.095	0.119	0.144	0.171	0.200	0.231	0.264	0.300	0.337	—	
TCF6024STAM TCF6024MEAM	600/1900 [283/896]	9.98 [0.93]	14/3	5		0.023	0.023	0.038	0.055	0.074	0.095	0.119	0.144	0.171	0.200	0.231	0.264	0.300	0.337	—	
TCF6024HTAM	600/1900 [283/896]	9.98 [0.93]	14/3			0.023	0.023	0.038	0.055	0.074	0.095	0.119	0.144	0.171	0.200	0.231	0.264	0.300	0.337	—	

**Important Note:** Gas furnace heating CFM can exceed the design cooling CFM. Ductwork and coil selection must accommodate the higher of the cooling or gas heating CFM to prevent furnace limit tripping, excessive noise, and coil freeze-up.

[ ] Designates Metric Conversions

**Table 2: Uncased Coil Dimensions and Weights**

Coil Model TCF	Connections		Uncased Coil Dimensions (in) [mm]		Weight	
	Sweat (in.) [mm]		A	B	Coil Weight (lbs.) [Kg.]	Shipping Weight (lbs.) [Kg.]
	Liquid	Suction				
	I.D.	I.D.				
2414ST	3/8 [9.53]	3/4 [19.05]	21 3/4 [552]	12 7/8 [327]	43 [19]	47 [21]
2417SP/2417ST/2417SE	3/8 [9.53]	3/4 [19.05]	15 3/8 [390]	16 3/8 [416]	43 [19]	48 [22]
2417MT/2417HT/3617ST/3617SP/3617SE	3/8 [9.53]	3/4 [19.05]	18 3/4 [476]	16 3/8 [416]	49 [22]	54 [24]
2421MT/2421HT/3621ST/3621SP/2421ME	3/8 [9.53]	3/4 [19.05]	18 3/4 [476]	19 7/8 [505]	51 [23]	60 [27]
3621MT/4821ST/4821SP/3621ME	3/8 [9.53]	3/4 [19.05]	26 5/8 [676]	19 7/8 [505]	71 [32]	78 [35]
2421UE/3621HT/4821MT/6021ST/6021SE/6021MT	3/8 [9.53]	7/8 [22.23]	33 [838]	19 7/8 [505]	76 [34]	86 [39]
3624MT/4824ST/4824ST	3/8 [9.53]	3/4 [19.05]	26 11/16 [678]	23 3/8 [594]	83 [37]	93 [42]
3624HT/4824HT/6024ST/6024HT/6024ME	3/8 [9.53]	3/4 [19.05]	30 15/16 [786]	23 3/8 [594]	100 [45]	108 [48]

\*The 14 inch, 2 ton RCF coil (2414) is part of the "N-Coil" design series, even though the coil shape resembles an "A" coil design.

**FIGURE 1: DIMENSIONS UNCASSED**

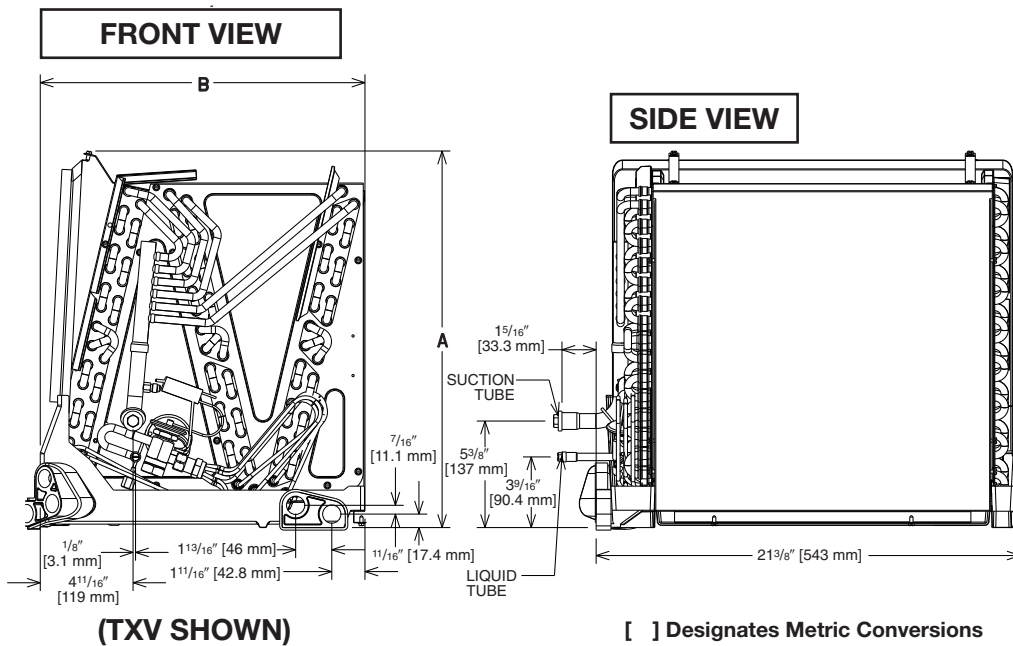
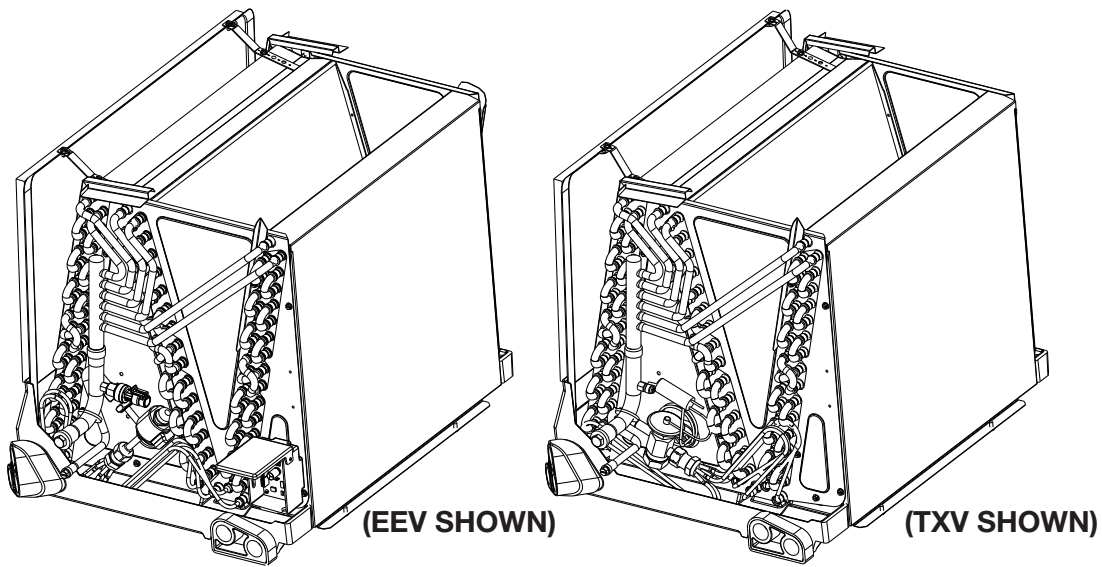
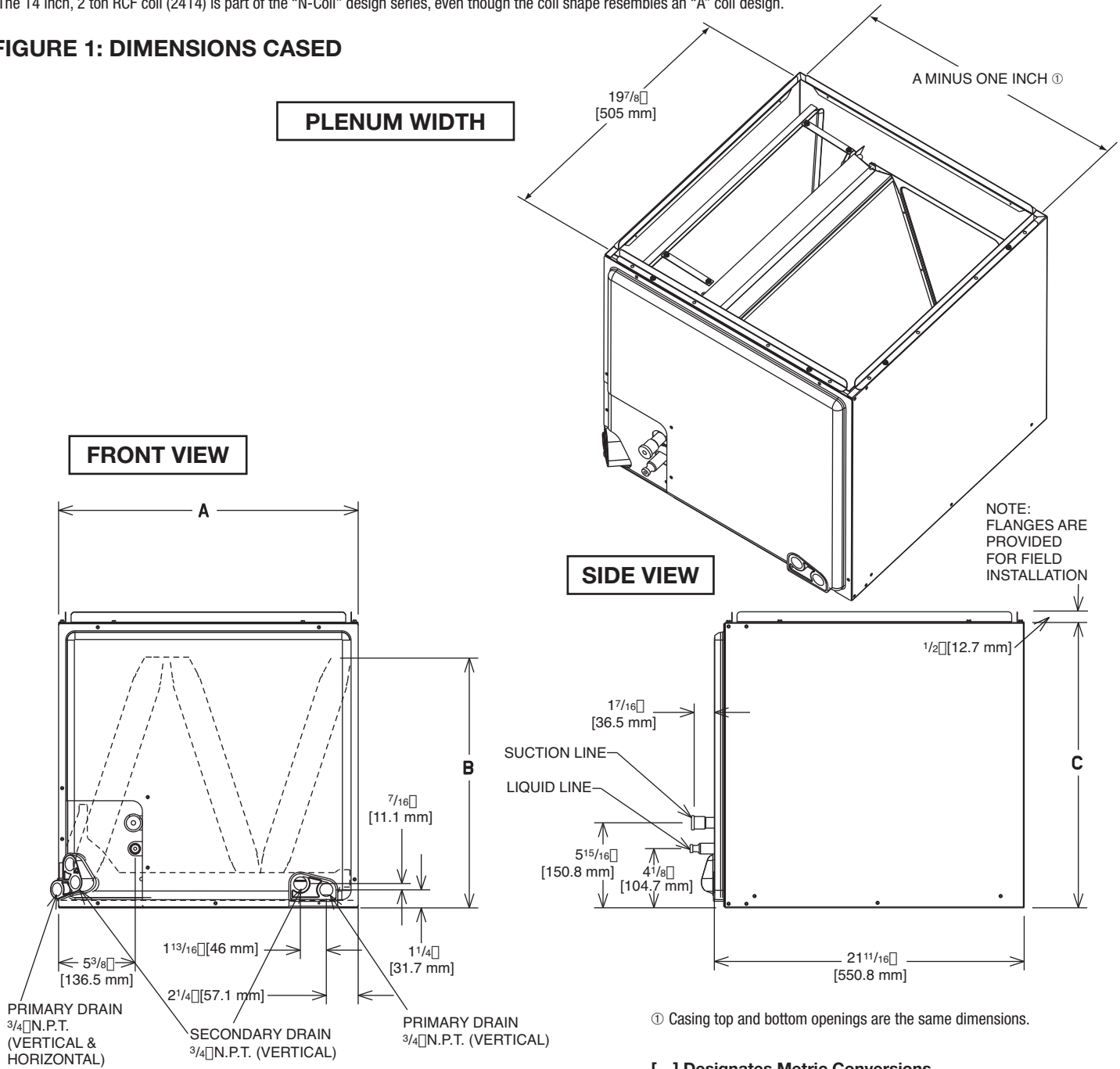

**Table 3: Cased Coil Dimensions and Weights**

Coil Model TCF	Connections		Cased Coil Dimensions (in) [mm]			Weight	
	Sweat (in.) [mm]		A	B	C	Coil Weight (lbs.) [Kg.]	Shipping Weight (lbs.) [Kg.]
	Liquid	Suction					
	I.D.	I.D.					
2414ST	3/8 [9.53]	3/4 [19.05]	14 [356]	21 [533]	23 <sup>3</sup> / <sub>16</sub> [584]	43 [19]	47 [21]
2417SP/2417ST/2417SE	3/8 [9.53]	3/4 [19.05]	17 <sup>1</sup> / <sub>2</sub> [445]	14 <sup>1</sup> / <sub>2</sub> [368]	20 [508]	43 [19]	48 [22]
2417MT/2417HT/3617ST/3617SP/3617SE	3/8 [9.53]	3/4 [19.05]	17 <sup>1</sup> / <sub>2</sub> [445]	17 <sup>7</sup> / <sub>8</sub> [454]	20 [508]	49 [22]	54 [24]
2421MT/2421HT/3621ST/3621SP/2421ME	3/8 [9.53]	3/4 [19.05]	21 [533]	17 <sup>1</sup> / <sub>2</sub> [445]	20 [508]	51 [23]	60 [27]
3621MT/4821ST/4821SP/3621ME	3/8 [9.53]	3/4 [19.05]	21 [533]	25 <sup>7</sup> / <sub>8</sub> [657]	28 [711]	71 [32]	78 [35]
2421UE/3621HT/4821MT/6021ST/6021SE/6021MT	3/8 [9.53]	7/8 [22.23]	21 [533]	32 [813]	34 <sup>1</sup> / <sub>2</sub> [876]	76 [34]	86 [39]
3624MT/4824ST/4824ST	3/8 [9.53]	3/4 [19.05]	24 <sup>1</sup> / <sub>2</sub> [622]	25 <sup>3</sup> / <sub>8</sub> [645]	32 <sup>1</sup> / <sub>2</sub> [826]	83 [37]	93 [42]
3624HT/4824HT/6024ST/6024HT/6024ME	3/8 [9.53]	3/4 [19.05]	24 <sup>1</sup> / <sub>2</sub> [622]	30 <sup>1</sup> / <sub>4</sub> [768]	32 <sup>1</sup> / <sub>2</sub> [826]	100 [45]	108 [48]

\*The 14 inch, 2 ton RCF coil (2414) is part of the "N-Coil" design series, even though the coil shape resembles an "A" coil design.

**FIGURE 1: DIMENSIONS CASED**



### Table 4: Coil Application

Coils can be matched to heating products as listed in table below.

Coil Model TCF	Furnace Width (In.) (mm)	
	Oil	Gas
2414ST 2417ST/ 2417SE 2417HT/2417MT 3617ST/ 3617SE	—	14 [356]
2417ST/2417SE 2417MT/2417HT/2417SP 3617ST/3617SP/3617SE	17½ [431]	17½ [444] 14 [356]
2421MT/2421HT/2421ME/2421UE 3621ST/3621SP/3621MT/3621ME 4821ST/4821SP/6021ST/6021SE/6021MT	21 [533]	21 [533] 17½ [444]
3624MT/3624HT 4824ST/4824HT/4824SP 6024ST/6024HT/6024ME	24½ [622]	24½ [622] 21 [533]

### Accessories

**• PLENUM ADAPTER ACCESSORY  
RXBA-AE**

This plenum adapter accessory is for use with the 24½" wide cased indoor cooling and heat pump coils. This allows a 24½" wide cased coil to be installed on a 28" wide oil furnace. This is a field-installed accessory only.

**• RXBA-AC (Upflow/Horizontal)**

These plenum adapter accessories are for use when a cooling coil is matched with a gas furnace of one smaller size.

**• HORIZONTAL ADAPTER KIT RXHH (See Figure 2)**

This horizontal adapter kit is used to convert a upflow or downflow coil (\*VUA) for a horizontal application. See Table 4 to order the proper horizontal adapter kit.

Table 4: Horizontal Adapter Kit Model No.

Coil Model	Horizontal Adapter Kit Model No.
2414S	RXHH-A01
2417S	RXHH-A02
2417M/2421M/3617S/ 3621S/2421H	RXHH-A03
3621M/3624M/ 4821S/4824S	RXHH-A04
3624H/4824H/ 6024S/6024H	RXHH-A05
2421U/3621H/4821M/ 6021S/6021M	RXHH-A06

FIGURE 2: HORIZONTAL ADAPTER KIT ILLUSTRATION

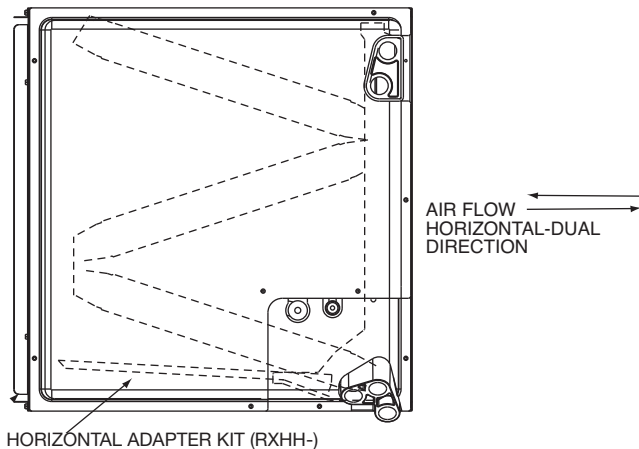

**• INDOOR COIL CASING- RXBC (See Table 5)**

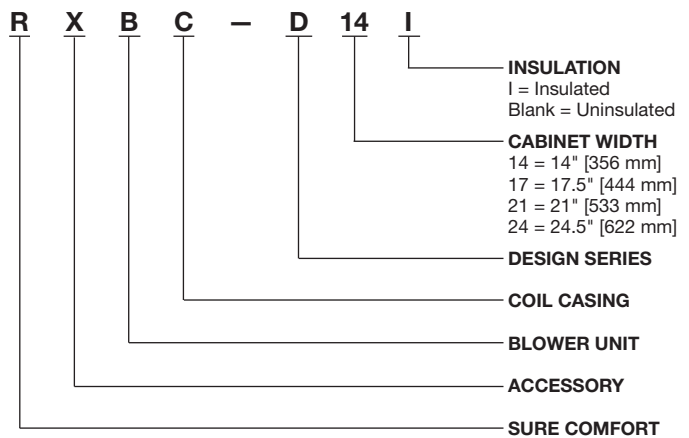

Table 5: Unit Dimensions and Weights- RXBC Indoor Coil Casings

Model Number	Width (in.) [mm]	Height (in.) [mm]	Depth (in.) [mm]	Unit Weight		Supply Air/Return Air Openings	
				Weight (lbs.) [Kg.]	Ship. Wt. (lbs.) [Kg.]	Width (in.) [mm]	Depth (in.) [mm]
RXBC-D14AI	14 [356]	23 <sup>3</sup> / <sub>16</sub> [589]	21 <sup>5</sup> / <sub>8</sub> [549]	19 [9]	23 [10]	13 [330]	19 <sup>31</sup> / <sub>32</sub> [508]
RXBC-D17AI	17½ [445]	20 [508]		18 [8]	23 [10]	16½ [419]	
RXBC-D21AI	21 [533]	20 [508]		20 [9]	26 [12]	20 [508]	
RXBC-D21BI	21 [533]	28 [711]		27 [12]	36 [17]	20 [508]	
RXBC-D24AI	24½ [622]	32½ [826]		34 [16]	44 [20]	23½ [597]	

Table 6: Uncased Coil Adapter Kit

Uncased Coil Adapter Model Number RXBA	A Width (in.) [mm]	Uncased Coil Model RCFP
B14x20	13 <sup>1</sup> / <sub>8</sub> [333]	-HUxx14
B17x20	16 <sup>5</sup> / <sub>8</sub> [422]	-HUxx17
B21x20	20 <sup>1</sup> / <sub>8</sub> [511]	-HUxx21
B24x20	23 <sup>5</sup> / <sub>8</sub> [599]	-HUxx24

[ ] Designates Metric Conversions



## Accessories (cont.)

### • UNCASSED COIL ADAPTER KIT

#### RXBA- (See Figure 3 & 4)

This uncased coil adapter kit is used to adapt the coil to a furnace or ductwork. See Table 6 to order the proper adapter kit. Each kit contains a quantity of 20 adapters.

FIGURE 3: UNCASSED COIL ADAPTER KIT ILLUSTRATION

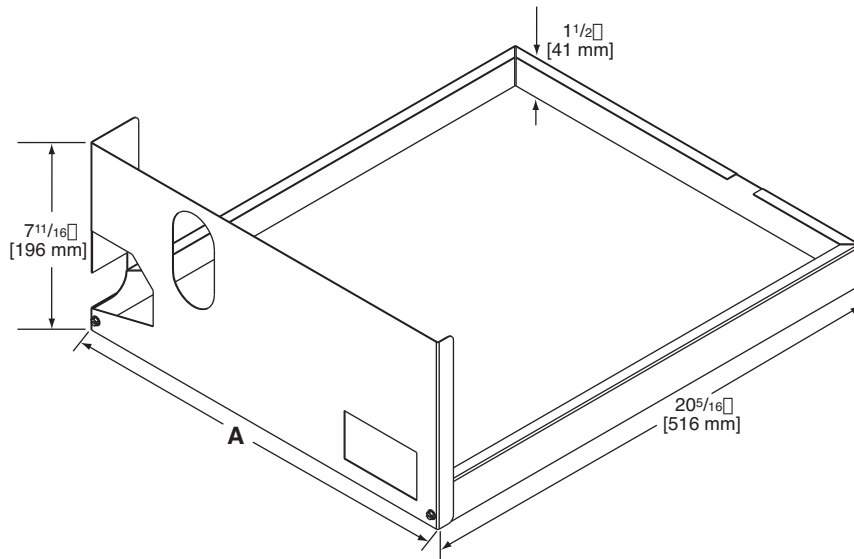
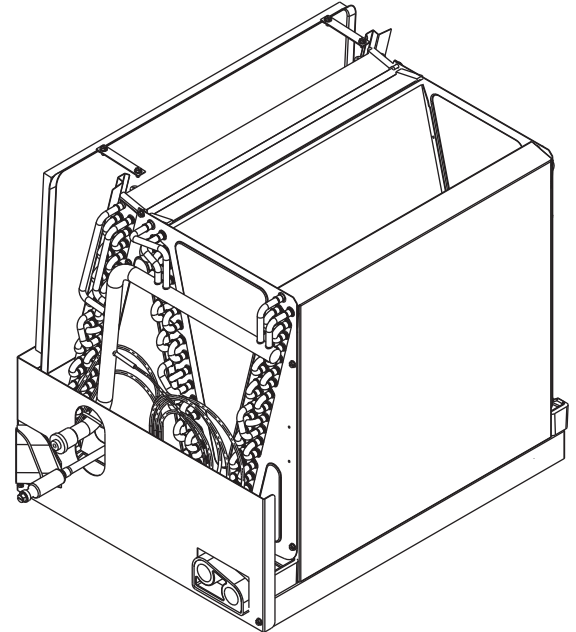

FIGURE 4: UNCASSED COIL ADAPTER KIT ASSEMBLED



Note: Sliding the coil into the coil rail before attaching coil rack front.

[ ] Designates Metric Conversions

## R-22 TXV Conversion Kits

To be used to convert R410-A coil to operate with R-22

FURNACE COIL CROSS REFERENCE CHART		
ORIGINAL COIL	RECOMMENDED ALUMINUM TUBE REPLACEMENT COIL	R-22 TXV CONVERSION KIT MODEL NO.
TCFA-**2414	TCF2414STAT	RXCT-HBA
TCFA-**2417	TCF2417STA	RXCT-HBA
TCFA-**3617	TCF3617STA, TCF2417MTA, or TCF2417HTA	RXCT-HBB
TCFA-**3621	TCF3621STA, TCF2417MTA, or TCF2421HTA	RXCT-HBB
TCFA-**4821	TCF4821STA or TCF3621MTA	RXCT-HBC
TCFA-**4824	TCF4824STA or TCF3624MTA	RXCT-HBC
TCFA-**6024	TCF6024STA, TCF6024HTA, TCF4824HTA, or TCF3624HTA	RXCT-HBD

\*\*= AU, HM, or HU

**GENERAL TERMS OF LIMITED WARRANTY\***

*Sure Comfort*® will furnish a replacement for any part of this product which fails in normal use and service within the applicable periods stated, in accordance with the terms of the limited warranty.

Conditional Parts .....Ten (10) Years

\*For complete details of the Limited and Conditional Warranties, including applicable terms and conditions, contact your local contractor or the Manufacturer for a copy of the product warranty certificate.





**Sure Comfort®**

5600 Old Greenwood Road, Fort Smith, AR 72908

Before proceeding with installation, refer to installation instructions packaged with each model, as well as complying with all Federal, State, Provincial, and Local codes, regulations, and practices.