



PROJECT NAME _____

LOCATION _____

ARCHITECT _____

ENGINEER _____

CONTRACTOR _____

SUBMITTED BY _____ DATE _____

UNIT SUMMARY

Quantity						
Unit Designation						
Model No.						
Total Cooling						
Sensible Cooling						
Air Ent. Evaporator						
Air Lvg. Evaporator						
Heating Input						
Heating Output						
CFM/ESP						
EER/SEER						
Electrical						
Minimum Ampacity						
Min.-Max. Breaker						
Net Unit Weight						
Accessory						
Catalog Form Number						

ACCESSORIES:

NOTES:

Versus™ Line W962W 4-Way Multi-Position Gas Furnaces

Heating Stages: Two-Stage

Input Rates: 40-115 kBTU [11.7-33.7 kW]

JOB NAME _____ LOCATION _____

CONTRACTOR _____ ORDER NO. _____

ENGINEER _____ UNIT MODEL NO. _____

SUBMITTED FOR APPROVAL RECORD COIL MODEL NO. _____

DATE _____ AIR HANDLER MODEL NO. _____

UNIT DATA

HEATING PERFORMANCE

TOTAL CAPACITY INPUT* _____ MBH [kW]
 TOTAL CAPACITY OUTPUT* _____ MBH [kW]
 DESIGN TEMP. RISE..... _____ °F [°C] DB
 AFUE _____ %
 CALIFORNIA SEASONAL EFFICIENCY _____ %
 (*uses blower motor heat)

SUPPLY AIR BLOWER PERFORMANCE

TOTAL AIR SUPPLY..... _____ CFM [L/s]
 TOTAL RESISTANCE EXTERNAL TO UNIT..... _____ IWG
 BLOWER SPEED..... _____ RPM
 POWER OUTPUT REQUIREMENT _____ BHP
 MOTOR RATING _____ HP [W]
 POWER INPUT REQUIREMENT _____ kW

ELECTRICAL DATA

POWER SUPPLY..... _____ Hz
 TOTAL UNIT AMPACITY..... _____ AMPS
 MINIMUM WIRE SIZE..... _____ AWG
 MAXIMUM OVERCURRENT DEVICE FUSES/HACR BREAKER _____ AMPS



FEATURES

- **Energy Efficiency:** ENERGY STAR® certified, featuring 96% AFUE across all model sizes
- **Diagnostics:** The Contractor App, built-in Bluetooth® technology makes monitoring, troubleshooting and repairing the product easier than ever before
- **Dip Switch Free Installation Commissioning via Bluetooth® Technology:** Seamless final install step without DIP switch configuration using the Contractor App
- **Ignition System:** Proven Direct Spark Ignition (DSI) for reliability and longevity
- **Water Management System:** Exclusive patented block drain sensor that automatically shuts off the furnace when the drain is blocked and alerts the contractor via diagnostic code
- **Two-Stage Heating:** Furnace operation mainly stays at low capacity around 60-65%, but will switch to high capacity to deliver stable heat distribution
- **Constant CFM Motor:** Truly variable speed technology allows for ultimate humidity control, quieter sound levels and year-round energy savings

FIELD INSTALLED ACCESSORIES

- Vent Termination Kits Concentric:
- Vert/Horz 2" Pipe (US only) = RXGY-E02
 - Vert/Horz 2" Pipe (US & Canada) = RXGY-E02A
 - Vert/Horz 3" Pipe (US only) = RXGY-E03
 - Vert/Horz 3" Pipe (US & Canada) = RXGY-E03A
 - Direct Vent Furnace Side Wall Vent 2" or 3" (US only) = RXGY-G02
 - External Bottom Filter Rack (Upflow/Horz) = RXGF-CB
 - External Side Filter Rack (Upflow) = RXGF-CD
 - External Filter Rack (Downflow) = RXGF-CC



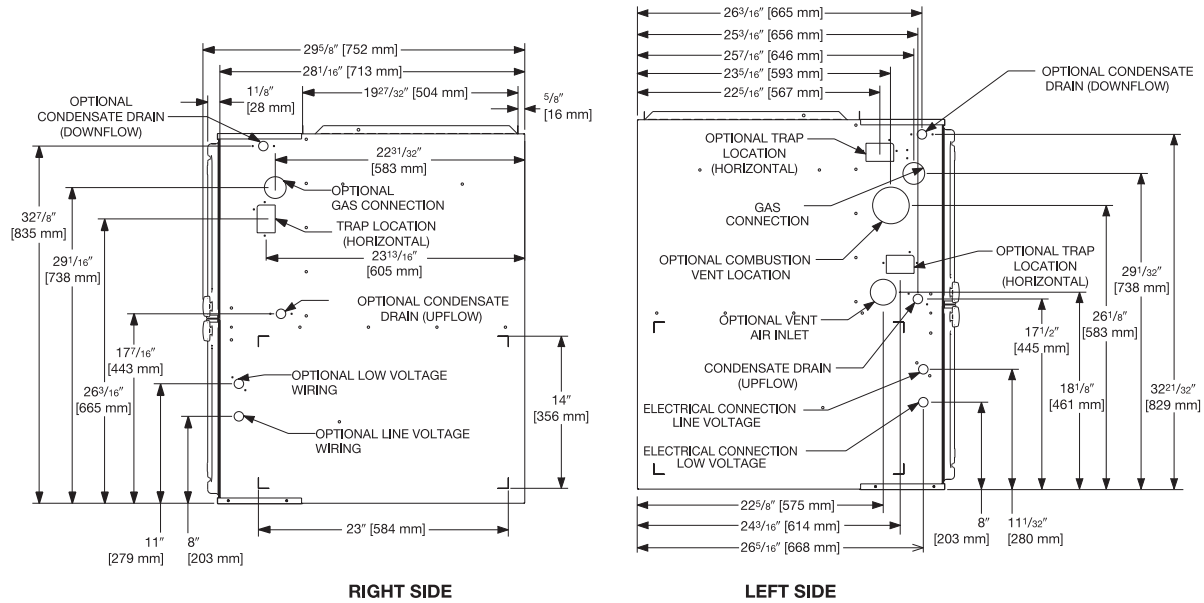
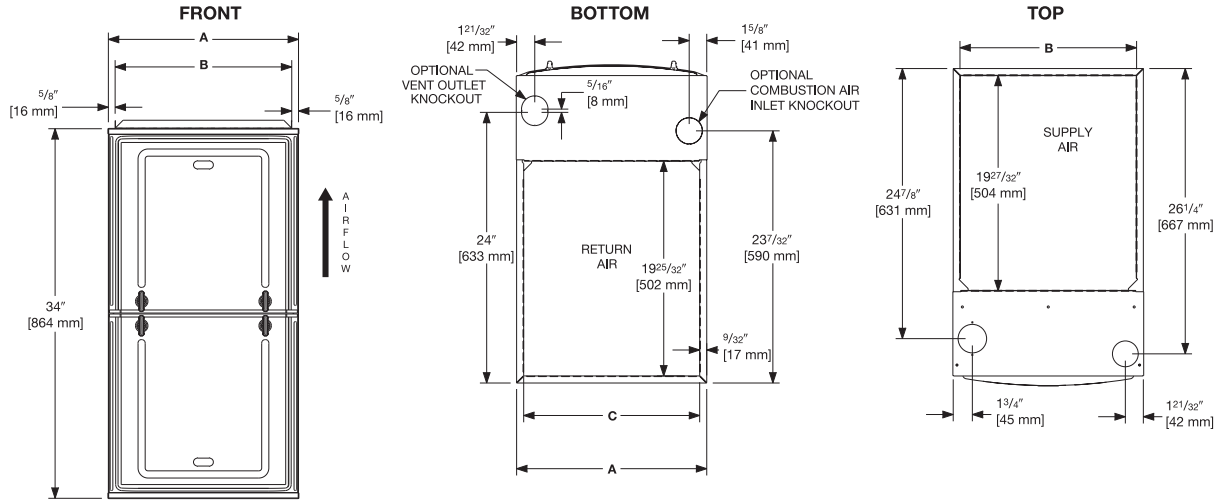

Unit Dimensions

MODEL W962W	LEFT SIDE	MINIMUM CLEARANCE (IN.) [mm]					FLANGE DIMENSIONS		
		RIGHT SIDE	BACK	TOP	FRONT	VENT	A	B	C
040	0	0	0	1 [25]	2 [51]	0	17 1/2 [445]	16 17/64 [413]	16 13/64 [412]
060	0	0	0	1 [25]	2 [51]	0	17 1/2 [445]	16 17/64 [413]	16 13/64 [412]
070	0	0	0	1 [25]	2 [51]	0	17 1/2 [445]	16 17/64 [413]	16 13/64 [412]
070 (wide)	0	0	0	1 [25]	2 [51]	0	21 [533]	19 49/64 [502]	19 45/64 [500]
085	0	0	0	1 [25]	2 [51]	0	21 [533]	19 49/64 [502]	19 45/64 [500]
100	0	0	0	1 [25]	2 [51]	0	21 [533]	19 49/64 [502]	19 45/64 [500]
115	0	0	0	1 [25]	2 [51]	0	24 1/2 [662]	23 17/63 [591]	23 13/64 [589]

[] Designates Metric Conversions

Before proceeding with installation, refer to installation instructions packaged with each model, as well as complying with all Federal, State, Provincial, and Local codes, regulations, and practices.