

HIGH EFFICIENCY CONDENSING HEATING BOILER

99,000 & 120,000 Btu/hr Models

(Natural Gas or Propane)

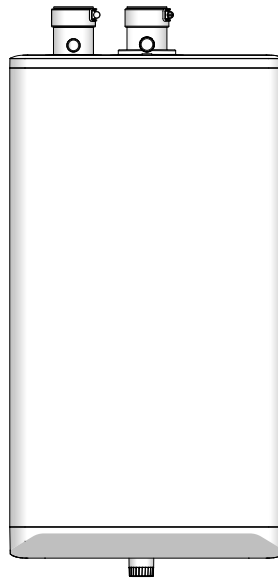

WARNING: If the information in this manual is not followed exactly, a fire or explosion may result causing property damage, personal injury, or loss of life.

Do not store or use gasoline or other flammable vapors and liquids or other combustible materials in the vicinity of this or any other appliance.

WHAT TO DO IF YOU SMELL GAS:

- Do not try to light any appliance.
- Do not touch any electrical switch; do not use any phone in your building.
- Immediately call your gas supplier from a neighbor's phone. Follow the gas supplier's instructions.
- If you cannot reach your gas supplier, call the fire department.

Installation and service must be performed by a qualified licensed installer, service agency or the gas supplier.



⚠ WARNING

If the information in this manual is not followed exactly, a fire or explosion may result causing property damage, personal injury, or loss of life.

SAFETY CONSIDERATIONS

Installation, start-up and servicing of the unit must be done with due care and attention, and must only be performed by competent, qualified, licensed and trained heating technicians. Failure to read and comply with all instructions and applicable National and local codes may result in hazardous conditions that could result in property damage and injury to occupants which in extreme cases might result in death.

HAZARDS & PRECAUTIONS**⚠ DANGER**

Points out an imminently hazardous situation which must be avoided in order to prevent serious injury or death.

⚠ WARNING

Points out a potentially hazardous situation which must be avoided to prevent serious injury or death.

⚠ CAUTION

Points out a potentially hazardous situation which must be avoided to prevent possible moderate injury and/or property damage

⚠ NOTE

Points out installation, maintenance and operation details that will result in enhanced efficiency, longevity and proper operation of your unit.

⚠ BEST PRACTICES

Points out recommendations for better installation.

Supplied with the unit - The unit is shipped with an accessory parts kit consisting of the following items:

- 1 x Wall Mounting Bracket Kit - Part # P-081344
- 1 x Condensate Trap Assembly
- 1 x Pressure Relief valve, 3/4" NPT, 30psi
- 1 x Outdoor Temperature Sensor
- 1 x Documentation set
- 1 x Propane Conversion Kit Part # P-081034 (99,000 Btu/hr) or Part # P-081054 (120,000 Btu/hr)

SPECIFICATIONS

SPECIFICATION	99,000 BTU	120,000 BTU
CSA Input (Natural Gas or Propane*) – MBH	15.5 - 99	13.65 - 120
CSA Input (Natural Gas or Propane*) – KW	4.5 - 29.0	4.0 - 35.2
CSA Output – MBH	14.8 - 89	13.0 - 108
CSA Output - KW	4.3 - 26.1	3.8 - 31.7
A.F.U.E	96%	95%
Min Gas Pressure (Nat. Gas or Propane*) – inch w.c.	4	4
Max Gas Pressure (Nat. Gas or Propane*) – inch w.c.	14	14
Power (120Vac/60Hz) - Watts @ full fire with internal pump	126	126
Weight (empty) – lbs/Kg	85 / 39	85 / 39
Pressure Vessel water content – USG/Liters	0.5 / 1.9	0.5 / 1.9
Max boiler flow rate - GPM (LPM)	10 (37.8)	11 (41.6)
Min boiler flow rate - GPM (LPM)	2 (7.6)	2 (7.6)
Max Operating Pressure – Space Heating Coil - (psig)†	43.5	43.5
Approved installation altitude - ASL (ft)	10,000	10,000
Ambient Temperature – Low (°F/°C)	32 / 0	32 / 0
Ambient Temperature – High (°F/°C)	122 / 50	122 / 50
Max relative humidity (non-condensing)	90%	90%
Min water Temperature (°F/°C)	51 / 10	51 / 10
Max water Temperature (°F/°C)	194 / 90	194 / 90
Max equivalent vent length 3" (each side)	120'	120'
Max equivalent vent length 2" (each side)	65'‡	65'‡

* Natural Gas units require a Propane conversion kit included with unit (see page #3-2, Table 9). Propane (LP) units require a Natural Gas conversion kit (see page #3-2, Table 9) to be ordered separately if converting a Propane unit to Natural Gas.

† units are shipped with 30 psig pressure relief valve

‡ The input rate will derate as vent length increases. Reference Table 3: Maximum Exhaust Venting Length in section 1.4.3 for details.

CONTENTS

1.0 INSTALLATION	1-1
1.1 GENERAL	1-1
1.2 CODE REQUIREMENTS	1-3
1.3 LOCATION	1-3
1.3.1 Removing/installing the front panel	1-5
1.4 EXHAUST VENTING AND AIR INTAKE	1-6
1.4.1 Applications	1-9
1.4.2 Exhaust Vent Material	1-9
1.4.3 Vent Travel	1-10
1.4.4 Venting Passage Through Ceiling and Floor	1-12
1.4.5 Rooftop Vent Termination	1-12
1.4.6 Sidewall Vent Termination	1-14
1.4.7 "Direct Vent" Combustion Air Intake Piping	1-18
1.4.8 "Indoor Air" Combustion Air Intake	1-19
1.4.9 Closet Installations	1-19
1.5 CONDENSATE REMOVAL	1-20
1.5.1 Condensate Trap	1-20
1.5.2 Installing the Condensate Trap	1-20
1.5.3 Further Installation Details	1-21
1.6 WATER PIPING - SPACE HEATING	1-23
1.6.1 General Piping Considerations	1-23
1.6.2 Basic Heating Piping Arrangements	1-27
1.7 GAS PIPING	1-32
1.8 ELECTRICAL CONNECTIONS	1-33
1.8.1 120VAC Line Voltage Hook-up	1-33
1.8.2 Accessing Controller Terminal Strip	1-33
1.8.3 External probe type low water cutoff device	1-35
1.8.4 Power Quality and Electrical Protection	1-35
1.8.5 Zone Valve and Zone Pump Connections	1-36
1.8.6 Thermostat / Sensor Wiring	1-36
2.0 UNIT SYSTEM OPERATION	2-1
2.1 GENERAL	2-1
2.2 CONTROL	2-2
2.3 INSTALLER INTERFACE	2-2
2.3.1 Turning Appliance ON/OFF	2-2
2.3.2 Programming Mode	2-3
2.4 DOMESTIC HOT WATER	2-5
2.4.1 Domestic Hot Water with an Indirect Water Heater	2-5
2.5 SPACE HEATING	2-5
2.5.1 Overview	2-5
2.6 SEQUENCE OF OPERATION	2-6
2.7 ACCESSING THE INFORMATION MENU	2-7
2.8 RESETTING THE MAINTENANCE COUNTER	2-9
3.0 STARTUP & COMMISSIONING	3-1
3.1 LIGHTING & SHUTTING DOWN THE UNIT	3-1
3.2 PRIOR TO START-UP	3-2
3.2.1 Pre-Ignition Checks	3-2

3.2.2 Test Ignition Safety Shutoff 3-2

3.3 COMMISSIONING 3-2

3.4 FUEL CONVERSION 3-4

 3.4.1 Gaining access to combustion chamber, burner removal instructions 3-5

4.0 MAINTENANCE 4-1

4.1 UNIT MAINTENANCE 4-1

 4.1.1 General Care 4-1

 4.1.2 Inspection 4-1

 4.1.3 Venting 4-1

 4.1.4 Condensate Trap 4-1

 4.1.5 Burner 4-1

 4.1.6 Heat Exchanger 4-2

 4.1.7 Pump 4-2

 4.1.8 Gas Piping 4-2

 4.1.9 Control Module 4-2

 4.1.10 Water Heating System 4-2

 4.1.11 Freeze Protection 4-2

 4.1.12 System Treatment 4-3

 4.1.13 Relief Valve - Maintenance and Testing 4-3

 4.1.14 Fan removal instructions 4-3

 4.1.15 Fan installation instructions 4-4

 4.1.16 Cleaning the Condensate Trap 4-4

 4.1.17 Reset the Maintenance Counter 4-6

 4.1.18 Winterization 4-6

5.0 TROUBLESHOOTING 5-1

5.1 PRELIMINARY CHECKS 5-1

5.2 ELECTRONIC COMPONENTS 5-2

 5.2.1 Temperature Sensors 5-2

 5.2.2 Fan/Blower 5-2

 5.2.3 Cabinet Sensors 5-3

 5.2.4 Thermostat Connections 5-3

 5.2.5 Water Pressure Sensor-Type Low Water Cut Off (LWCO) 5-3

 5.2.6 Flue Gas Temperature Sensor 5-4

 5.2.7 Outdoor Sensor 5-4

 5.2.8 DHW Tank Sensor 5-4

5.3 FAULTS AND NOTIFICATIONS 5-5

 5.3.1 Fault Codes 5-5

 5.3.2 Notification Codes 5-9

5.4 OTHER FAULTS 5-11

 5.4.1 No heat (space heating) 5-11

 5.4.2 Space heating does not reach the correct temperature 5-11

 5.4.3 Space heating system remains too warm 5-12

 5.4.4 Burner ignites loudly 5-12

 5.4.5 Burner resonates 5-12

6.0 REPLACEMENT KITS 6-1

7.0 WIRING DIAGRAMS 6-3

 INSTALLATION & COMMISSIONING REPORT 6-5

 SERVICE RECORD 6-6

 NOTES 6-8

⚠ DANGER

Should overheating occur or the gas supply fails to shut off, do not turn off or disconnect the electrical supply to the pump. Instead shut off the gas supply at a location external to the appliance.

⚠ WARNING

Do not use this unit if any part has been under water. Immediately call a qualified service technician to inspect the unit and to replace any part of the control system and any gas control that has been under water.

⚠ CAUTION

Care must be taken to properly size the unit for its intended use. Prolonged full-fire run time, over-sizing or under-sizing, and incorrect flow rates through the unit can lead to increased maintenance costs, equipment stress and premature failure.

PRE-INSTALLATION CHECK

Carefully consider clearances and access, vent travel and termination, gas supply, condensate removal and combustion air supply.

Consider the following:

- Install the unit in areas where the combustion air source is free of contamination. Exposure to corrosive chemical fumes such as chlorinated and/or fluorinated hydrocarbons can reduce the life of a unit. Cleaners, bleaches, air fresheners, refrigerants, aerosol propellants, dry-cleaning fluids, de-greasers and paint-removers all contain vapors that can form corrosive acid compounds when burned in a gas flame. Avoid airborne chlorides such as those released with the use of laundry detergents.
- Locate the unit where water leakage will not result in damage to the area (for example, do not install above carpeting). If you cannot find a suitable location, install a drain pan with an adequate drain under the appliance.
- At a new construction site, or during renovations, protect the unit from drywall dust or other construction related contaminants.
 - Ensure combustion air is drawn from a CLEAN source (e.g. outdoors).
 - Isolate the unit from interior dust sources.
- When the unit is in operation, assess the impact of the steam plume normally experienced at the exhaust terminal of a condensing unit. Generally, intake and exhaust pipes should terminate at a rooftop or wall location free of obstructions. Unit condensate is corrosive. Protective measures must be taken to prevent corrosion damage to metal roofs or other metal building components in contact with the condensate. Keep exhaust plumes well away from all building air intakes including those of neighboring properties by following all requirements of the jurisdiction having authority and this installation manual.
- Place the exhaust outlet so it reaches 12" minimum above the down-turned intake, to avoid flue gas contamination of the combustion air.
- For sidewall venting options: Both the inlet and exhaust terminations must be located on the same side of the building. You can elevate both pipes in "periscope style" after passing them through the wall to gain required clearance above grade and snow level.
- Examine the condensate outlet to ensure proper disposal of condensate will occur during operation. A condensate neutralizer must be installed if the condensate will flow into a drain subject to corrosion.
- Ensure that the pressure relief valve is installed with no valves or other means of isolation between its inlet and the unit. Pipe the relief valve with unobstructed piping (minimum 3/4" diameter) to a safe discharge location.
- In locations where power supply quality varies or is unstable, consider installing surge protection and power conditioners (up to and including battery back-up uninterrupted power supply devices).

NOTE

When using the unit for non-domestic purposes, the warranty conditions and maintenance periods described in this document are no longer valid. Consult the included warranty documentation for details.

1.0 INSTALLATION**1.1 GENERAL**

This High Efficiency Condensing Heating Boiler with variable input ranges (see *specification chart - page 3*) is designed to be used for domestic (residential) purposes. Domestic use is considered to be an average annual gas usage of less than 140,000ft³ (4000 m³) for natural gas or 1,500 gallons (5,680 L) for propane. The units are approved as "Category IV" vented appliances using Direct Vent (sealed combustion).

Figures 1a and 1b show outer case dimensions and piping. Use this diagram to find a suitable location for the unit. See also *Section 1.3 Location*.

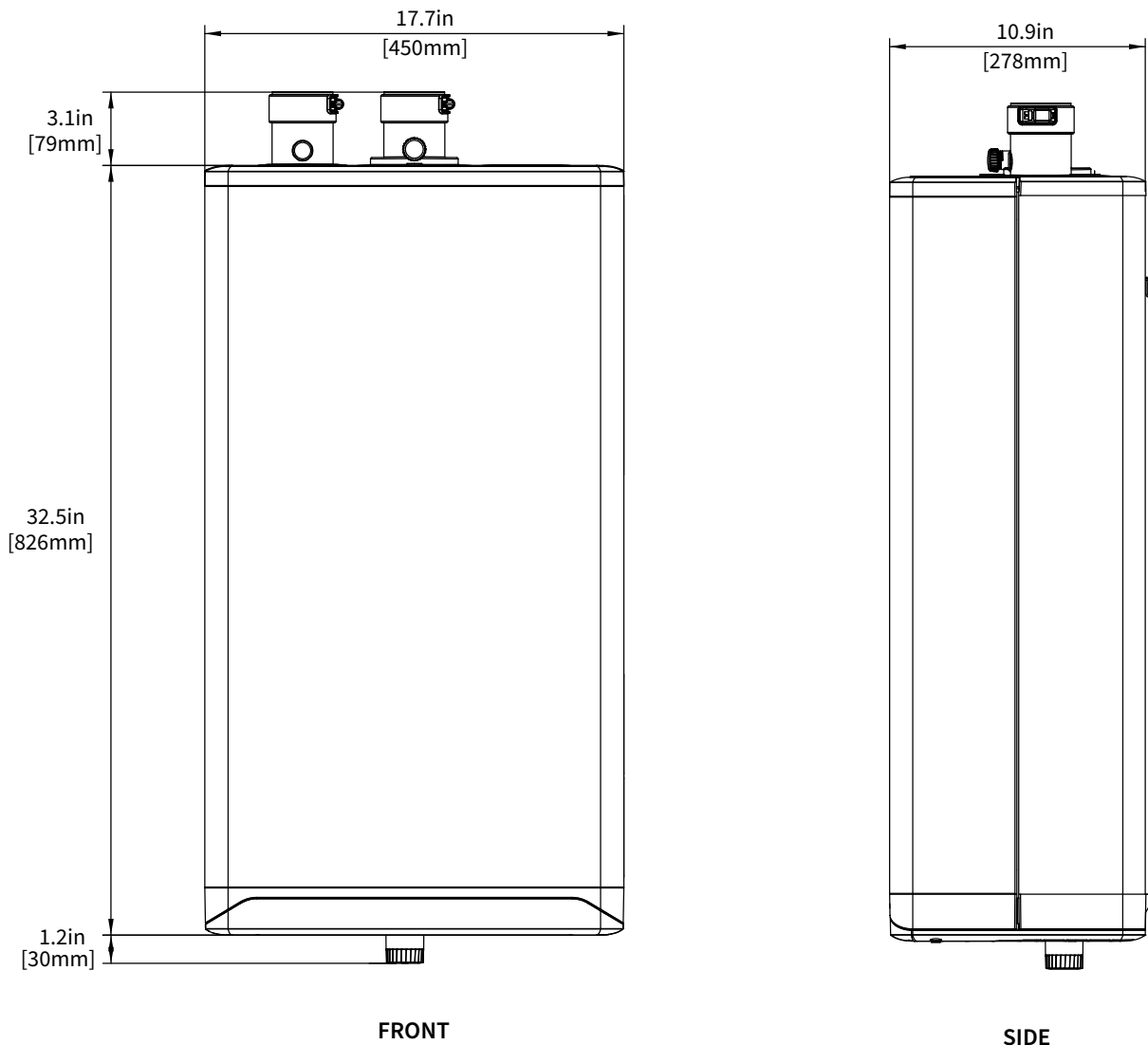

Figure 1a: Dimensions / Connections for Heating Boilers

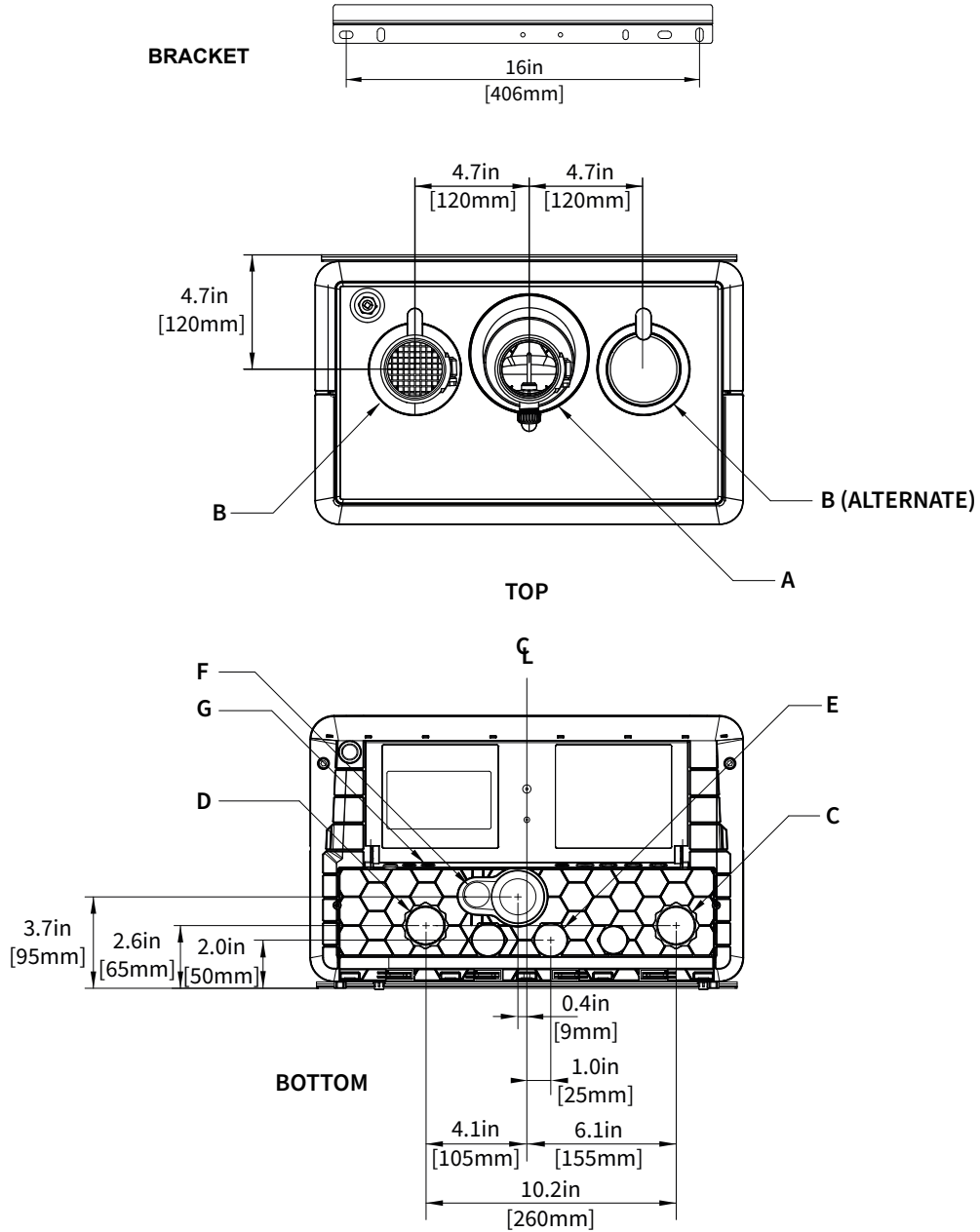

Figure 1b: Dimensions / Connections for Heating Boilers

DESCRIPTION	DIMENSION
A Exhaust Outlet	2" Schedule 40 PVC
B Combustion Air inlet	2" Schedule 40 PVC
C Heating Water Inlet (Return)	1" Male NPT
D Heating Water Outlet (Supply)	1" Male NPT
E Gas Inlet	3/4" Male NPT
F Condensate Outlet	3/4" Hose
G Control Wiring Entrance	7/16" Rubber Plug

Table 1: Connections

⚠ WARNING

- Keep the unit area free and clear of combustible materials, gasoline, and other flammable vapors and liquids.

- Combustion air must not be drawn from areas containing corrosive air from swimming pools or spas, including air directly next to outdoor pools and spas.

- The unit must not be exposed to water leaks from piping or components located overhead. This includes condensation dropping from un-insulated cold water lines overhead.

- Ensure the gas ignition system components are protected from water (dripping, spraying, rain, etc.) during appliance operation and when servicing (pump replacement, condensate trap servicing, control replacement, etc.)

- California Proposition 65

This product contains chemicals known to the state of California to cause cancer, birth defects, or other reproductive harm.

1.2 CODE REQUIREMENTS

The Heating Boiler is certified under CSA 4.9 / ANSI Z21.13.

The installation must conform to the requirements of the authority having jurisdiction or, in the absence of such requirements, to the *National Fuel Gas Code, ANSI Z223.1/NFPA 54, (latest edition) in the US or Natural Gas and Propane Installation Code, CSA B149.1 (latest edition) in Canada*. The installation must also conform to the Canadian Electrical Code Part 1 in Canada or the National Electrical Code ANSI/NFPA 70 (latest edition) in the US. Where required by the authority having jurisdiction, the installation must conform to the Standard for Controls and Safety Devices for Automatically Fired Boilers, ANSI/ASME CSD-1. If there is any conflict, then the more stringent will apply.

1.3 LOCATION

All Heating Boiler models are designed and approved for indoor installation. Its venting options provide flexibility of location; for example, placement in an alcove, basement, utility room or closet. The unit is approved for installation in a closet (see Table 2 for clearances to combustibles).

Conditions for safe installations

Ensure that the surrounding conditions are between 32°F [0°C] and 122°F [50°C] and less than 90% relative humidity.

Install the unit in areas where the combustion air source is free of contamination.

Exposure to corrosive chemical fumes such as chlorinated and/or fluorinated hydrocarbons can reduce the life of a unit. Cleaners, bleaches, air fresheners, refrigerants, aerosol propellants, dry-cleaning fluids, de-greasers and paint-removers contain vapors that can form corrosive acid compounds when burned in a gas flame. Also avoid airborne chlorides such as those released with the use of laundry detergents.

This unit must not be installed in an area where water leakage will result in damage to the areas adjacent or below the unit. When such areas cannot be avoided, a suitable drain pan with adequate drain must be installed under the unit.

Unit fastening

Approximate weight for the unit is 85 lbs / 39 kg. For support fasteners, use at least two of the four supplied 1/4" x 1 3/4" long lag screws. Installers must supply 1/4" bolts if metal mounting systems are used. Attach the wall mounting bracket to a structurally sound wall that is capable of supporting the combined weight of the unit and piping components which can exceed 150 lbs. (68kg).

Unit clearance

Other factors affecting potential mounting sites:

- Ensure minimum clearance requirements for combustible materials (see Table 2) are satisfied.
- For ease of access, we recommend a minimum 24" clearance at the front and 24" above. Check local codes for additional access and service clearance requirements.
- **At a new construction site, or during renovations, protect the unit from drywall dust or other construction related contaminants. Combustion air must be drawn from a CLEAN source (e.g. outdoors) and the unit must be isolated from interior dust sources.**

⚠ WARNING

- Exposed water piping and associated components (relief valves, circulators, etc.) must not be in contact with combustible materials. Check local codes for required clearances and/or provide adequate insulation.

- DO NOT MOUNT THIS UNIT TO A HOLLOW SHEET ROCK WALL USING ANCHORS. The wall mounting bracket must be bolted to wall studs or a solid wall structure to support the combined weight of the unit which can exceed 150 lbs. (68kg) once installed.

- Take precautions to avoid injury during the installation of this unit.

SURFACE	DISTANCE FROM COMBUSTIBLE SURFACES	RECOMMENDED DISTANCE FOR INSTALLATION AND SERVICE
Front	2"	24"
Rear	0"	0"
Left Side	1.5"	6" (labels may be difficult to read with reduced clearance)
Right Side	4"	6" (labels may be difficult to read with reduced clearance)
Top	2"	24"
Bottom	8"	24"

Table 2: Clearance from the unit cabinet

You must provide a minimum distance below the unit of 8" to allow clearance for the supplied condensation trap assembly. More clearance will typically be required to accommodate associated water and gas piping.

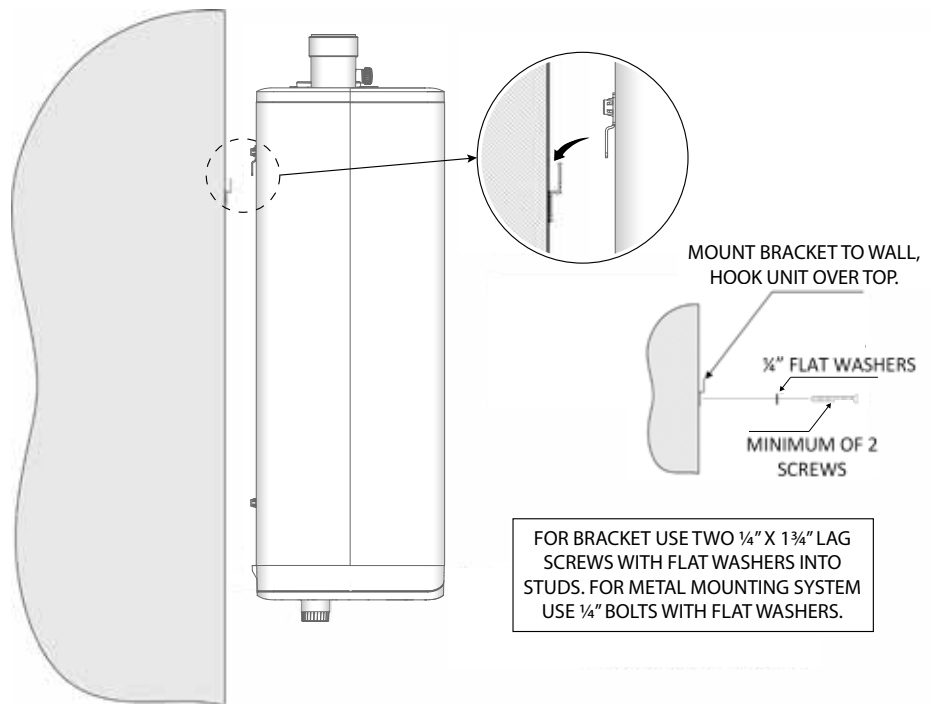

Figure 2: Wall mounting of unit

⚠ CAUTION

The front panel has a rubber seal around the inner edge sometimes making it very stiff to slide off so please ensure the unit is secured to the wall correctly before attempting this procedure!

1.3.1 Removing/installing the front panel

- The front panel of the unit must be removed to perform various maintenance activities.
- Loosen both screws (1) under the unit by using a 5 mm allen key. (They are captive and therefore will not drop out of the lower housing).
- Slide the front panel (2) upward and then remove it by pulling it towards you.

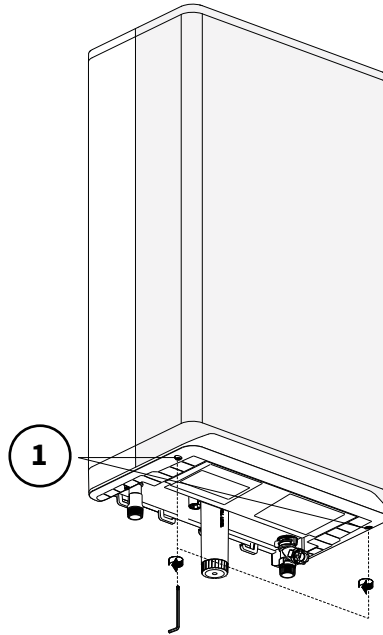

Figure 3: Loosen screws

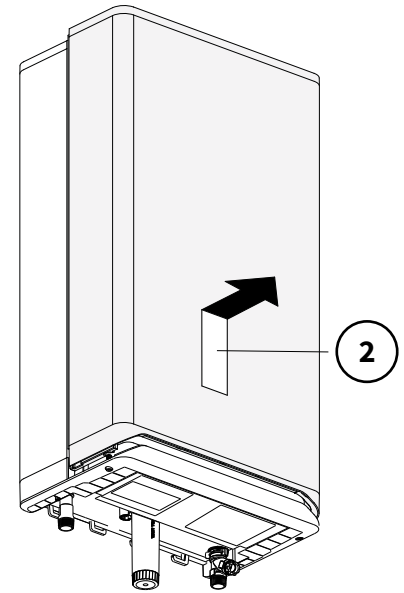

Figure 4: Frontpanel upward

⚠ WARNING

This is a room sealed cover and therefor extremely important that it is fitted correctly, failure to do so can result in flue gas spillage and carbon monoxide emissions, causing severe personal injury or death.

To replace the front panel, proceed as follows:

- Position the front panel (3) against the unit and slide it downwards until it is correctly connected to the lower fascia panel.
- Hand tighten screws under the unit using a 5 mm allen key (do not over tighten)

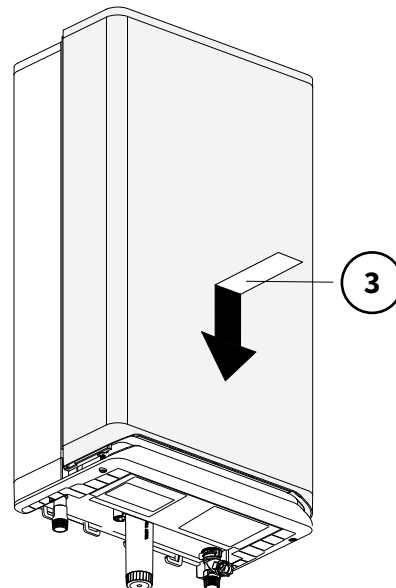

Figure 5: Positioning the frontpanel

⚠ DANGER

Failure to properly vent the unit to the outdoors as outlined in this Venting section will result in death or serious personal injury. To avoid the risk of fire, explosion, or asphyxiation from carbon monoxide, **NEVER** operate the unit unless it is properly vented and has adequate air supply for proper operation as outlined in this Venting section. This unit must have air supply connected and terminated to the outdoors.

⚠ WARNING

- Venting, condensate drainage, and combustion air systems for all units must comply with applicable codes and the instructions of their respective Installation manuals.

- Inspect finished vent and air piping thoroughly to ensure all are airtight and comply with the instructions provided and with all requirements of applicable codes.

- Failure to follow all instructions can result in flue gas spillage and carbon monoxide emissions, causing severe personal injury or death. Failure to comply will result in severe personal injury or death.

⚠ DANGER

Do not common vent this Heating Boiler with any other existing or new appliance.

1.4 EXHAUST VENTING AND AIR INTAKE

When you plan the installation, ensure that you consider appropriate venting materials, travel and termination decisions.

Consider the following when selecting a vent termination location:

- Select a location where the units exhaust will not damage nearby plants, shrubs, air conditioning equipment or be objectionable to the homeowner.
- Exhaust gases will form a visible plume during cold weather. Avoid areas where the plume could obstruct window views.
- Prevailing winds could cause water/ice buildup on nearby objects including building surfaces.
- Avoid locations where people or pets could come in contact with exhaust gases.
- Avoid locations such as inside building corners, near adjacent buildings or surfaces, window wells, stairwells, alcoves, courtyards, or other recessed areas where wind could affect the unit's performance or cause exhaust gas recirculation.
- Select a location where the termination is not likely to be damaged by foreign objects such as stones or balls, or is subject to buildup of debris such as leaves.

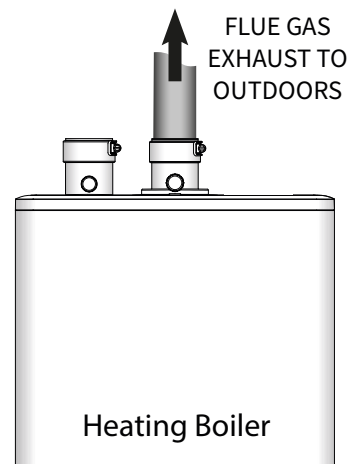

Figure 6: Basic exhaust vent assembly

Install venting in accordance with the requirements of the jurisdiction having authority: in Canada, Part 8, *Venting Systems* of the B149.1-10 Code and any other local building codes are to be followed. In the USA the National Fuel Gas Code, ANSI Z223.1, latest edition, prevails. Where there is a discrepancy between the installation instructions below, and the code requirements, you must apply the more stringent of the two requirements

Provisions for combustion and ventilation air in accordance with the section "Air for Combustion and Ventilation", of the *National Fuel Gas Code, ANSI Z223.1/ NFPA 54* (latest edition) in the US or Clause 8.2, 8.3 or 8.4 of *Natural Gas and Propane Installation Code, CAN/CSA B149.1* (latest edition) in Canada. or applicable provisions of the local building codes.

NOTE

For the State of Massachusetts, use only plastic piping, fittings and vent terminations as specified in this manual which are approved by the Massachusetts Board of State Examiners of Plumbers and Gas for venting of appliances (see hyperlink below):

https://licensing.reg.state.ma.us/pubLic/pl_products/pb_pre_form.asp

In the Commonwealth of Massachusetts

The Commonwealth of Massachusetts requires compliance with regulation 248 CMR 4.00 and 5.00 for installation of through-the-wall vented gas appliances as follows:

(a) For all side-wall, horizontally vented, gas-fueled equipment installed in every dwelling, building, or structure used in whole or part for residential purposes, including those owned or operated by the Commonwealth and where the side-wall exhaust vent termination is less than seven (7) feet above finished grade in the area of the venting, including but not limited to decks and porches, the following requirements shall be satisfied.

1. INSTALLATION OF CARBON MONOXIDE DETECTORS. At the time of installation of the side-wall, horizontally vented, gas-fueled equipment, the installing plumber or gas fitter shall observe that a hard-wired carbon monoxide detector with an alarm and battery backup is installed on the floor level where the gas equipment is to be installed. In addition, the installing plumber or gas fitter shall observe that a battery-operated or hard-wired carbon monoxide detector with an alarm is installed on each additional level of the dwelling, building, or structure served by the side-wall, horizontally vented, gas-fueled equipment. It shall be the responsibility of the property owner to secure the services of qualified licensed professionals for the installation of hard-wired carbon monoxide detectors.

a. In the event that the side-wall, horizontally vented, gas-fueled equipment is installed in a crawl space or an attic, the hard-wired carbon monoxide detector with alarm and battery backup may be installed on the next adjacent floor level.

b. In the event that the requirements of this subdivision cannot be met at the time of completion of installation, the owner shall have a period of thirty (30) days to comply with the above requirements, provided, however, that during said thirty (30) day period, a battery-operated carbon monoxide detector with an alarm shall be installed.

2. APPROVED CARBON MONOXIDE DETECTORS. Each carbon monoxide detector as required in accordance with the above provisions shall comply with NFPA 720 and be ANSI/UL 2034-listed and IAS-certified.

3. SIGNAGE. A metal or plastic identification plate shall be permanently mounted to the exterior of the building at a minimum height of eight (8) feet above grade directly in line with the exhaust vent terminal for the horizontally vented, gas-fueled heating appliance or equipment. The sign shall read, in print size no less than one-half (1/2) inch in size, "GAS VENT DIRECTLY BELOW. KEEP CLEAR OF ALL OBSTRUCTIONS."

4. INSPECTION. The state or local gas inspector of the side-wall, horizontally vented, gas-fueled equipment shall not approve the installation unless, upon inspection, the inspector observes carbon monoxide detectors and signage installed in accordance with the provisions of 248 CMR 5.08 (2)(a)(1 through 4).

(b) EXEMPTIONS: The following equipment is exempt from 248 CMR 5.08 (2)(a) (1 through 4):

1. The equipment listed in Chapter 10 entitled "Equipment Not Required To Be Vented" in the most current edition of NFPA 54 as adopted by the Board, and
2. Product-approved side-wall, horizontally vented, gas-fueled equipment installed in a room or structure separate from the dwelling, building, or structure used in whole or in part for residential purposes.

(c) **MANUFACTURER REQUIREMENTS – GAS EQUIPMENT VENTING SYSTEM PROVIDED.** When the manufacturer of product-approved side-wall, horizontally vented, gas-fueled equipment provides a venting system design or venting system components with the equipment, the instructions provided by the manufacturer for installation of the equipment and the venting system shall include:

1. Detailed instructions for the installation of the venting system design or the venting system components; and
2. A complete parts list for the venting system design or venting system.

(d) **MANUFACTURER REQUIREMENTS – GAS EQUIPMENT VENTING SYSTEM NOT PROVIDED.** When the manufacturer of product-approved side-wall, horizontally vented, gas-fueled equipment does not provide the parts for venting the flue gases, but identifies “special venting systems,” the following requirements shall be satisfied by the manufacturer:

1. The referenced “special venting systems” instructions shall be included with the appliance or equipment installation instructions, and
2. The “special venting systems” shall be product-approved by the Board, and the instructions for that system shall include a parts list and detailed installation instructions.

(e) A copy of all installation instructions for all product-approved side-wall, horizontally vented, gas-fueled equipment, all venting instructions, all parts lists for venting instructions, and/or all venting design instructions shall remain with the appliance or equipment at the completion of the installation.

⚠ CAUTION

- The minimum wall thickness for venting is 1" and the maximum wall thickness for venting is 14".

- Do not connect this Heating Boiler to a chimney flue serving a separate appliance designed to burn solid fuel.

- The air intake fitting can be moved to the left or to the right of the exhaust fitting.

⚠ NOTE

The flue gas temperature sensor reports the current flue gas exhaust temperature to the unit's controller. If necessary, the controller will reduce the input of the boiler to meet the flue gas exhaust temperature requirements of PVC material. The controller locks out the unit if this temperature is exceeded, and displays F003.

Removal of Existing Unit from Common Venting

When an existing unit is removed from a common venting system, the common venting system is likely to be too large for proper venting of the appliances remaining connected to it.

At the time of removal of an existing unit, the following steps must be followed with each appliance remaining connected to the common venting system placed in operation, while the other appliances remaining connected to the common venting system are not in operation.

- Seal any unused openings in the common venting system.
- Visually inspect the venting system for proper size and horizontal pitch, and determine that there is no blockage or restriction, leakage, corrosion and other deficiencies that could cause an unsafe condition.
- Insofar as is practical, close all building doors and windows and all doors between the space in which the appliances remaining connected to the common venting system are located and other spaces of the building. Turn on clothes dryers and any appliance not connected to the common venting system. Turn on any exhaust fans, such as range hoods and bathroom exhausts, so they will operate at maximum speed. Do not operate a summer exhaust fan. Close fireplace dampers.
- Place in operation the appliance being inspected. Follow the lighting instructions. Adjust the thermostat, so that the appliance operates continuously.
- Test for spillage at the draft hood relief opening after 5 minutes of main burner operation. Use the flame of a match or candle, or smoke from a cigarette, cigar, or pipe.
- After it has been determined that each appliance remaining connected to the common venting system properly vents when tested as outlined above, return doors, windows, exhaust fans, fireplace dampers and any other gas-burning appliance to their previous conditions of use.
- Any improper operation of the common venting system must be corrected so the installation conforms with the National Fuel Gas Code, ANSI Z223.1/NFPA 54 (latest edition) in the US or the Natural Gas and Propane Installation Code, CSA B149.1 (latest edition) in Canada. When resizing any portion of the common venting system, the common venting system must be resized to approach the minimum size as determined using the appropriate tables in the National Fuel Gas Code, ANSI Z223.1/NFPA 54 (latest edition) in the US or the Natural Gas and Propane Installation Code, CSA B149.1 in Canada.

1.4.1 Applications

All Heating Boiler models must be installed as a Direct Vent venting system. The combustion air must be piped in from the outdoors and connected directly to the unit's combustion air connection. See section 1.4.7 for air intake piping requirements.

1.4.2 Exhaust Vent Material

Use of ABS, cellular core PVC (ASTM F891), cellular core CPVC, or Radel® (polyphenolsulfone) in venting systems is prohibited.

Exhaust Vent Material – CANADA

Use only PVC, CPVC, Polypropylene (PPS), or stainless steel* vent components.

⚠ WARNING

- Do not mix venting materials from different venting manufacturers.

These venting materials are designed to be installed as part of a complete system.

Failure to comply may result in severe personal injury or death.

- Fully insert the approved venting material into the unit's exhaust outlet and tighten clamp to ensure the venting connection is locked in place.

⚠ NOTE

For the State of Massachusetts, use only plastic piping, fittings and vent terminations as specified in this manual which are approved by the Massachusetts Board of State Examiners of Plumbers and Gas for venting of appliances (see hyperlink below):

https://licensing.reg.state.ma.us/pubLic/pl_products/pb_pre_form.asp

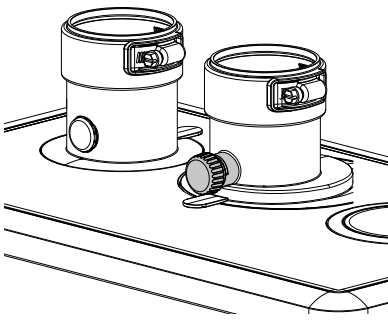

Figure 7 Inlet and outlet vent connections. Note the flue exhaust test port.

Venting components must be approved for use with a Category IV appliance, listed under ULC S636 and must comply with CSA B149.1 (latest edition).

- PVC (ULC-S636)
- CPVC (ULC-S636)
- Polypropylene (ULC-S636)
- Stainless steel* (ULC-S636)

Exhaust Vent Material – USA

Use only PVC, CPVC, Polypropylene (PPS), or Stainless Steel* vent components. Venting components must be approved by the authority having jurisdiction and as follows:

- PVC (Schedule 40 ASTM D1785)
- CPVC (Schedule 40 ASTM F441)
- Polypropylene (UL1738 / ULC-S636)
- Stainless Steel* (Type BH)
 - DuraVent FasNSeal
 - HeatFab Saf-T Vent
 - Z-Flex Z-Vent

This unit is equipped with a top mounted 2" vent connection. Wet the vent connection gasket and pipe with clean water prior to assembly. Insert 2" PVC or CPVC directly into the units vent connection and secure the pipe by tightening the clamp.

Polypropylene venting will require an adapter from the venting manufacturer to transition from the 2" vent connection to the venting system. Centrotherm InnoFlue polypropylene venting requires adapter part number ISAAL0202. Wet the vent connection gasket and adapter with clean water prior to assembly. Insert the polypropylene adapter into the units vent connection and secure by tightening the clamp.

***Manufacturers of stainless steel Type BH venting systems must submit their approved transition fitting to us for evaluation and written approval.**

1.4.3 Vent Travel

The maximum exhaust venting length is dependent upon the vent pipe size (2" or 3") and the venting material (PVC, CPVC, PPs). See Table 3 for maximum exhaust venting lengths and the required venting length reduction for each fitting in the venting system.

Example: When using 6 x 90° CPVC elbows, the maximum lineal measure of pipe allowed using 3" pipe is 72 feet ($120' - (6 \times 8' = 48') = 72'$).

For 3" Flexible PPs, up to 35 actual lineal feet are allowed in a nominally vertical orientation ($>45^\circ$). The equivalent length of 3" Flexible PPs is calculated using a multiple of 1.4:1, e.g. $35' \times 1.4 = 49'$ equivalent. The balance of the venting allowance is still available for use with rigid PPs piping material.

2" Flexible PPs is not allowed.

⚠ WARNING

Combustion air must not be drawn from areas containing corrosive air from swimming pools or spas, including air directly next to outdoor pools and spas.

⚠ BEST PRACTICES

To reduce the possibility of expansion noise, allow a 1/4" gap around the exhaust and air intake piping.

⚠ NOTE

The bird screen is optional for exhaust piping in cold weather climates.

EXHAUST PIPE SIZE/FITTINGS MAXIMUM EQUIVALENT LENGTH

Schedule 40 PVC, CPVC or PPs – Allowances are for each side separately.	
2"	65*
3"	120'
2" or 3" 90° Long Sweep Vent Elbow	Allow 5 equivalent feet
2" or 3" 90° Short Sweep Vent Elbow	Allow 8 equivalent feet
2" or 3" 45° Vent Elbow	Allow 3 equivalent feet
PPS	
PPs 87-90° Elbow	Allow 8 equivalent feet
Flex PPS	
2" PPs Flex	Not Allowed
3" PPs Flex	35' Actual (Equivalent = Actual x 1.4)

Table 3: Maximum Exhaust Venting Length

* The input rate will derate as vent length increases. See table below for approximate derate at 2" maximum vent length.

MAXIMUM FIRING RATE	APPROXIMATE DERATE
99,000	5 - 8%
120,000	10 - 16%

Follow all installation instructions supplied by the pipe and fitting manufacturer. Prior to assembly, ensure all venting components are clean of burrs/debris which could clog the fan, burner, and heat exchanger.

General Venting/Piping Requirements

If the vent length requires increasing the vent pipe size to 3", the transition from the 2" vent connector to 3" venting must occur within the first 18" of the top of the unit and must be done in a vertical section to avoid pooling of condensate. Slope exhaust venting back towards the unit with a pitch of at least 1/4" per foot. Follow venting manufacturer pitch requirements, so condensate runs back towards the trap. Support air intake and vent piping per local code and vent manufacturers requirements. In the absence of support requirements, support the air intake and vent piping at every vertical and horizontal transition as well as every 5' of run.

Begin the vent system installation at the unit and work towards the outdoor termination. We recommend using a bird screen of 1/4" stainless steel or plastic mesh (e.g., IPEX System 636 drain grate for CPVC systems) to guard against foreign objects.

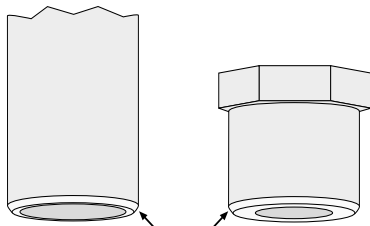

ENSURE PIPE AND FITTINGS ARE BEVELED FOR TROUBLE-FREE INSERTION THROUGH EXHAUST AND INTAKE PIPE GASKETS
WET GASKETS AND PIPE BEFORE INSERTION

Figure 8

⚠ CAUTION

Vent termination clearances in this section are code minimum, or recommended minimum requirements, and may be inadequate for your installation. You must examine building envelope details, and take measures to avoid admission of moisture into building structures. Serious structural damage may occur if adequate precautions and clearances are not allowed for.

These precautions are to be observed for neighboring structures as well as for the structure the unit(s) are installed in.

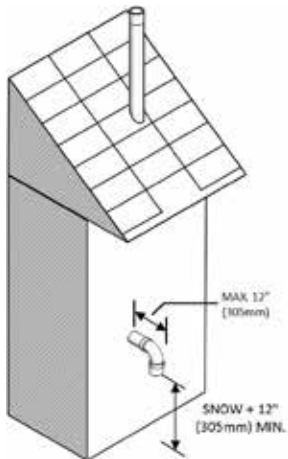

Figure 9: Rooftop vent terminal configurations

⚠ WARNING

Condensate can cause corrosion of metal roofing components and other roofing materials. Check with the builder or roofing contractor to ensure that materials are resistant to acidic condensate. pH levels can be as low as 3.0

Secure joints using appropriate solvent cement to bond the respective pipe material (Canada: PVC/CPVC cement approved under *ULC-S636*, in accordance with its manufacturer instructions; USA: PVC (ASTM D2564), or CPVC (ASTM F493) Use transition cement anywhere that PVC and CPVC are joined. Follow the cement manufacturer's instructions closely when joining various components. For PPs, connections must be secured using approved retainer clips supplied by the respective PPs manufacturer.

Ensure that all vent connections are liquid and pressure tight. Prior to firing the unit, and before any of the venting run is concealed by the building construction, you must test the exhaust joints with a soap/water solution. You must fill the condensate trap before testing.

1.4.4 Venting Passage Through Ceiling and Floor

- Confirm material meets local codes including fire stopping requirements. Some local jurisdictions require that a minimum initial length of pipe be exposed or accessible for inspection.
- Pipe clearances - best practice allows a minimum 1/4" gap around the pipe to prevent binding and expansion noise. Follow local codes.
- All piping must be liquid and pressure tight.

1.4.5 Rooftop Vent Termination**Direct Vent - Two Pipe**

Rooftop vents must terminate as follows:

- The exhaust pipe can terminate in an open vertical orientation without concern about rain infiltration; rain will drain away through the condensate trap.
- The intake air pipe is not typically drained, so it must be terminated with a down-turned elbow (see Figure 10). The intake pipe does not need to penetrate the roof at the same elevation as the exhaust (as shown); lower down the roof is OK.
- The air intake pipe may terminate on the side wall of the building as long as

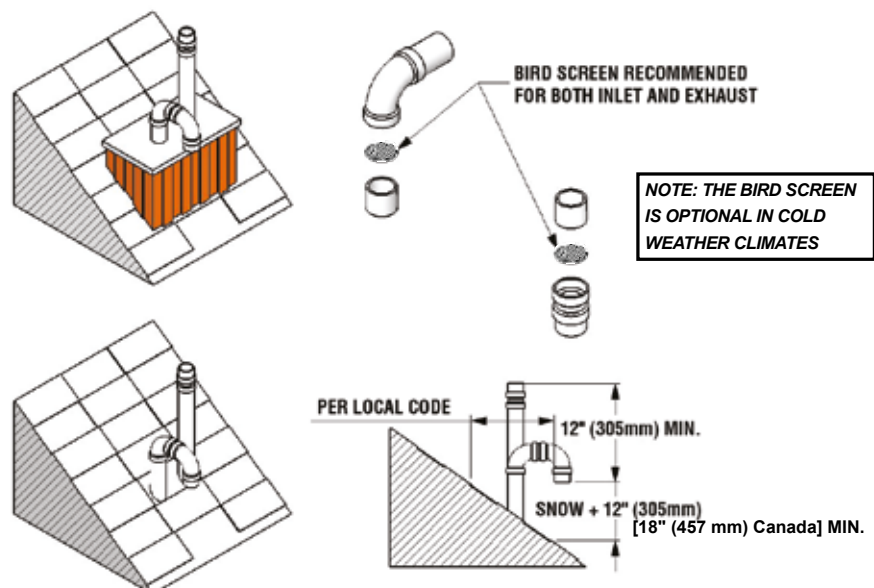

Figure 10: Rooftop vent terminal configurations

the air intake terminal is turned down and the side wall of the building is not exposed to large wind loads i.e., prevailing wind (see Figure 9).

- Optional bird screen may be placed in a termination fitting. Leave unglued, and hold in place with a short nipple to allow easy access for cleaning.
- For roof top venting of multiple unit sets, group all intake terminals together for a common penetration through a custom cap. Alternatively, place in the closest proximity achievable using commonly available pipe flashing. Similarly, group the exhaust pipes and place the 2 separate groups of pipes at least 3' apart (the closest intake and exhaust pipes must be 36" - or more - apart). Use the same 12" (minimum) vertical separation for 2 pipe option.
- **DO NOT exhaust vent into a common venting system.**

DIRECT VENT CONCENTRIC ROOF TOP TERMINATION

Roof Top Concentric Termination kits are approved for use with this unit. For vertical roof top concentric terminations, you must follow the installation instructions supplied by the manufacturer. Care must be taken to install the termination kit a minimum horizontal distance of 10" (305 cm) away from any portion of the building and a minimum of 12" (305 mm) [18" (457 mm) Canada] above the roof line plus the anticipated snow line (see Figures 11 and 12).

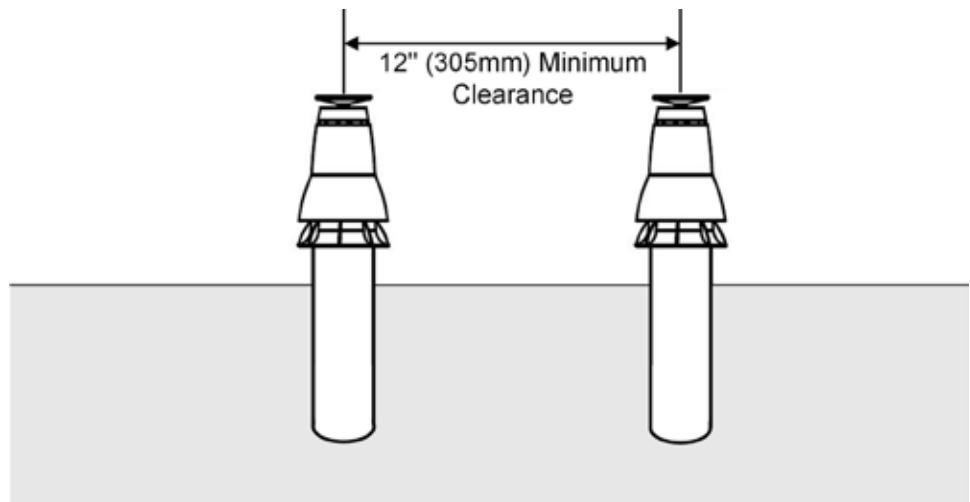

Figure 11: Vertical Concentric Termination - Two Kits

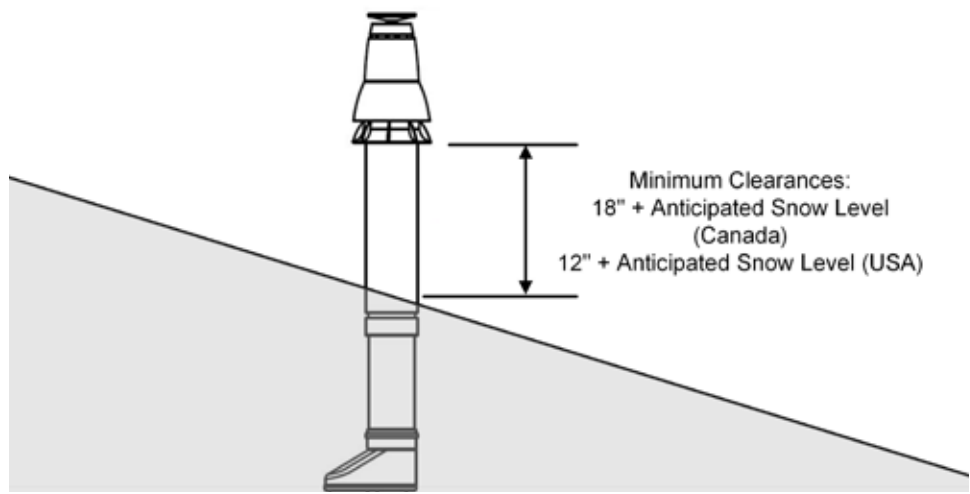

Figure 12: Vertical Concentric Termination - Single Kit

⚠ WARNING

- You must maintain at least the minimum separation of exhaust vent termination from unit's intake air as illustrated in figures 9, 10, 13 and 15. Failure to do so can result in a dangerous situation where exhaust gases are pulled in with combustion air. Damage to the unit can result from a failure to maintain these separations. Improper installation will void the warranty.

- You must not cover non-metallic vent pipe and fittings with thermal insulation.

- In areas of high snowfall, users must be advised to check side wall vent and air intake terminations on a regular basis to ensure blockage does not occur.

⚠ WARNING

The vent for this appliance must not terminate:

1. Over public walkways in the US. In Canada 7' above public walkways.
2. Near soffit vents or crawl space vents or other areas where condensate or vapor could create a nuisance or hazard or cause property damage.
3. Wherever condensate vapor could cause damage or could be detrimental to the operation of regulators, relief valves, or to other equipment.

1.4.6 Sidewall Vent Termination**Direct Vent - Two Pipe**

Sidewall direct vent applications must be vented as follows:

- Both the inlet and exhaust terminations must be located on the same plane (side) of the building.
- The exhaust outlet is to be placed so as to reach 12" minimum above the down-turned intake - to avoid intake re-ingestion of exhaust gases.
- The elevation of both pipes can be raised in "periscope style" after passing through the wall, then configured as in *Figure 13*, to gain required clearance.
- Use a 45° elbow on the exhaust termination to launch the plume up and off the sidewall, for protection of wall.
- Optional bird screen may be placed in a termination fitting. Leave unglued, and hold in place with a short nipple to allow easy access for cleaning.

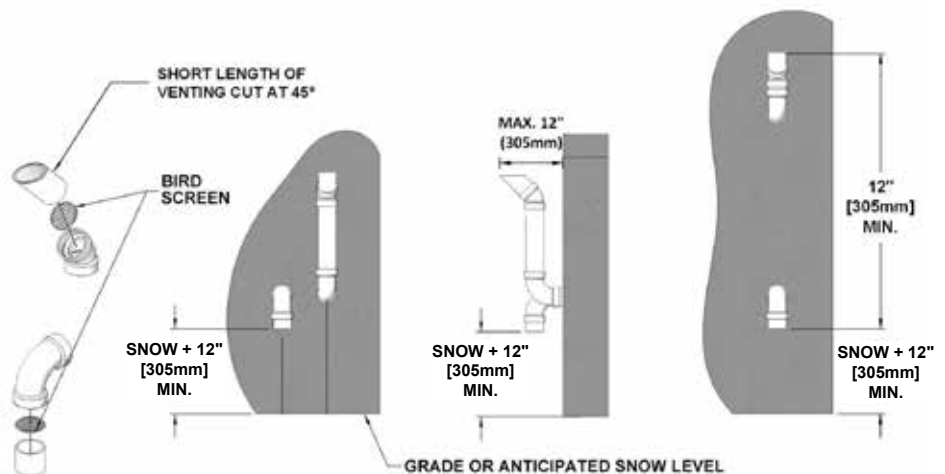

Figure 13: Sidewall vent termination - piping configuration



Figure 14: Prohibited installation

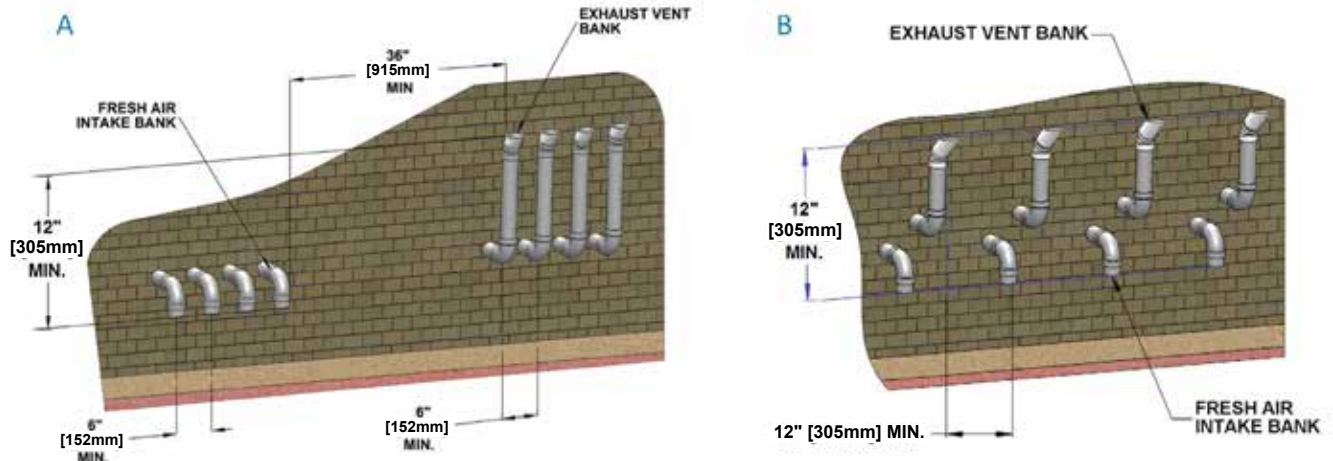

Figure 15: Sidewall vent termination - multiple vent piping configuration

For sidewall venting of multiple units, group all intake terminals together with 6" (minimum) lateral spacing, and similarly group the exhaust pipes. Place the 2 groups on the same plane of the building (e.g., north facing wall). Place the 2 groups of pipes at least 3' apart (the closest intake and exhaust pipes must be 36" - or more - apart). Use same 12" (minimum) vertical separation (see A in Figure 15). Alternatively, as long as the units are identical models - intake and exhaust terminals can maintain a minimum of 12" of separation horizontally from any exhaust or inlet termination of an adjacent unit (see B in Figure 15).

DIRECT VENT SIDE WALL TERMINATION KITS

The Side Wall Termination kits approved for use with the Heating Boilers are subject to restrictions. **NOTE:** Some jurisdictions may not allow this type of side wall termination due to close proximity to the neighboring properties. See Figures 16, 17 and 18 on page 1-15, 1-16

You must follow the installation instructions, clearances and wall thickness requirements of the approved vent termination manufacturer.

Approved Side Wall Termination Kits are listed below:

- 2" PVC low profile termination kit - Part #P-741
- 3" PVC low profile termination kit - Part #P-742

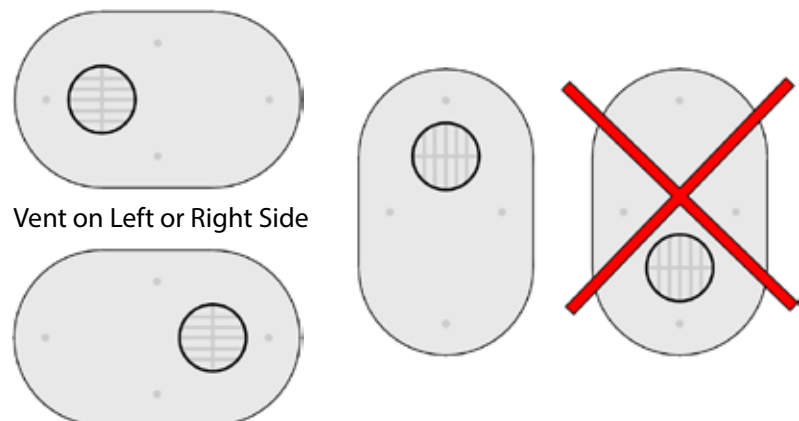

Figure 16 PVC low profile termination acceptable orientations

Concentric SideWall Termination Kits

Concentric Sidewall Termination kits approved for use with the Heating boiler are subject to restrictions. NOTE: Some jurisdictions may not allow this type of sidewall termination due to close proximity to the neighboring properties.

You must follow the installation instructions, clearances, and wall thickness requirements of the approved vent termination manufacturer.

Approved Concentric Sidewall Termination kits are:

- 3" PVC (UL 1738) – Ipex #397006
- 3" PVC (ULC-S636) – Ipex #196006
- 3" CPVC (ULC-S636) – Ipex #197009
- 2" Centrotherm InnoFlue PPs - #ICWT242 (Termination)
#ICTCR24 (2 Pipe Adapter)
- 3" Centrotherm InnoFlue PPs - #ICWT352 (Termination)
#ICCT3503 (2 Pipe Adapter)

Installation of multiple Concentric Side Wall Termination kits must be:

- On the same horizontal line (not stacked)
- With a minimum horizontal separation of 12" center to center.

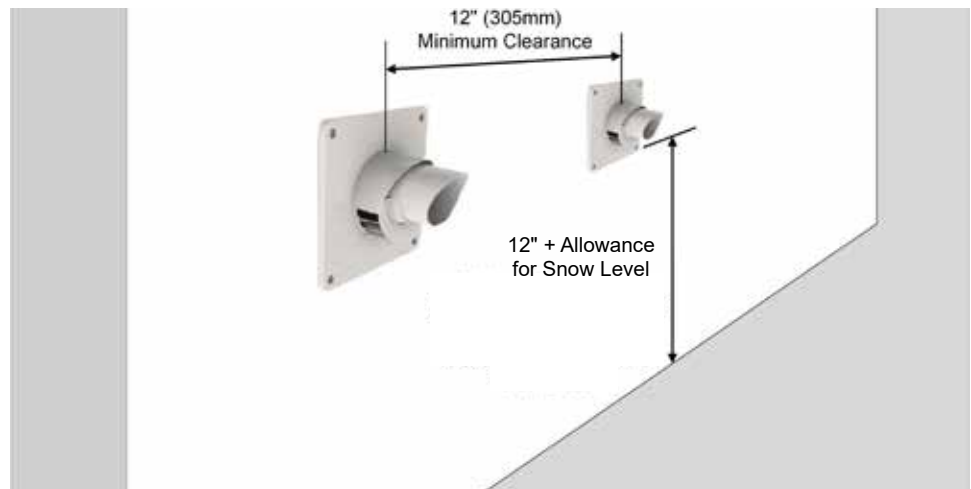

Figure 17: Horizontal Polypropylene Concentric Termination - Two Kits

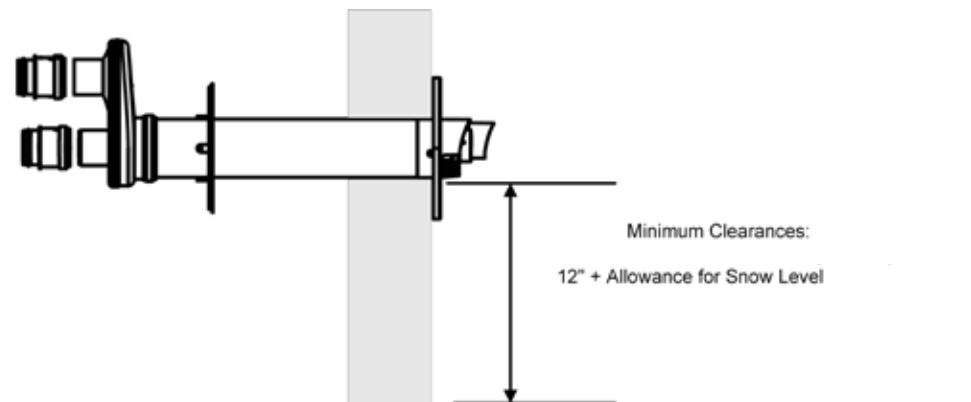

Figure 18: Horizontal Polypropylene Concentric Termination - Single Kit

⚠ WARNING

- In addition to preventing ingestion of chemical contaminants, care must be taken to ensure air intake terminals are not installed in locations where contamination might occur due to ingestion of particulate foreign material (dust, dirt and debris).

- Intake air openings must be configured such that rain or other forms of moisture cannot enter the air intake piping system. Otherwise serious damage to the unit may result.

⚠ NOTE

Care must be taken when installing air intake piping to ensure that a “trap” is not formed in the piping so as to allow a build-up of water, and blockage of intake air. Such blockage will result in a unit’s safety shutdown.

Vent terminal clearance minimums are as follows:

VENT TERMINAL MINIMUM CLEARANCES		
	CANADIAN INSTALLATIONS^{1, 3}	US INSTALLATIONS^{2, 3}
A= Clearance above grade, veranda, porch, deck, or balcony	12 in (30 cm)	12 in (30 cm)
B= Clearance to window or door that may be opened	12 in (30cm) for appliances below 100,000 Btuh (30 kW) 36 in (91 cm) for appliances over 100,000 Btuh (30 kW)	12 in (30 cm)
C= Clearance to permanently closed window	* (Recommend minimum 1 ft (30 cm))	* (Recommend minimum 1 ft (30 cm))
D= Vertical clearance to ventilated soffit located above the terminal within a horizontal distance of 2 ft (61 cm) from the center line of the terminal.	* (Recommend minimum 2 ft (61 cm))	* (Recommend minimum 2 ft (61 cm))
E= Clearance to unventilated soffit	* (Recommend minimum 1 ft (30 cm))	* (Recommend minimum 1 ft (30 cm))
F= Clearance to outside corner	* (Recommend minimum 4 ft (122 cm))	* (Recommend minimum 4 ft (122 cm))
G= Clearance to inside corner	* (Recommend minimum 4 ft (122 cm))	* (Recommend minimum 4 ft (122 cm))
H= Clearance to each side of center line extended above meter/regulator assembly	3 ft (91 cm) within a height of 15 ft (4.6m)	*
I= Clearance to service regulator vent outlet	3 ft (91 cm)	*
J= Clearance to nonmechanical air supply inlet to building or the combustion air inlet to any other appliance	12 in (30cm) for appliances below 100,000 Btuh (30 kW) 36 in (91 cm) for appliances over 100,000 Btuh (30 kW)	12 in (30 cm)
K= Clearance to a mechanical air supply inlet	6 ft(1.83 m)	3 ft (91 cm) above if within 10 ft (3 m) horizontally
L= Clearance above paved sidewalk or paved driveway located on public property	7 ft (2.13 m) †	Vents cannot be located above public walkways or other areas where condensate or vapor can cause a nuisance or hazard.
M= Clearance under veranda, porch, deck, or balcony	12 in (30 cm) ‡	*
Clearance to adjacent wall	6 ft (1.83 m)	6 ft (1.83 m)

1 In accordance with the current CSA B149.1 Natural Gas and Propane Installation Code

2 In accordance with the current ANSI Z223.1 / NFPA 54 National Fuel Gas Code

3 If locally adopted installation codes specify clearances different than those illustrated, then the most stringent shall apply.

† A vent shall not terminate directly above a sidewalk or paved driveway that is located between two single family dwellings and serves both dwellings.

‡ Permitted only if veranda, porch, deck, or balcony is fully open on a minimum of two sides beneath the floor.

* Clearance in accordance with local installation codes and the requirements of the gas supplier. The minimum distance from adjacent public walkways, adjacent buildings, openable windows, and building openings shall not be less than those values specified in the National Fuel Gas Code, ANSI Z223.1/NFPA 54, and/or the Natural Gas and Propane Installation Code, CSA B149.1

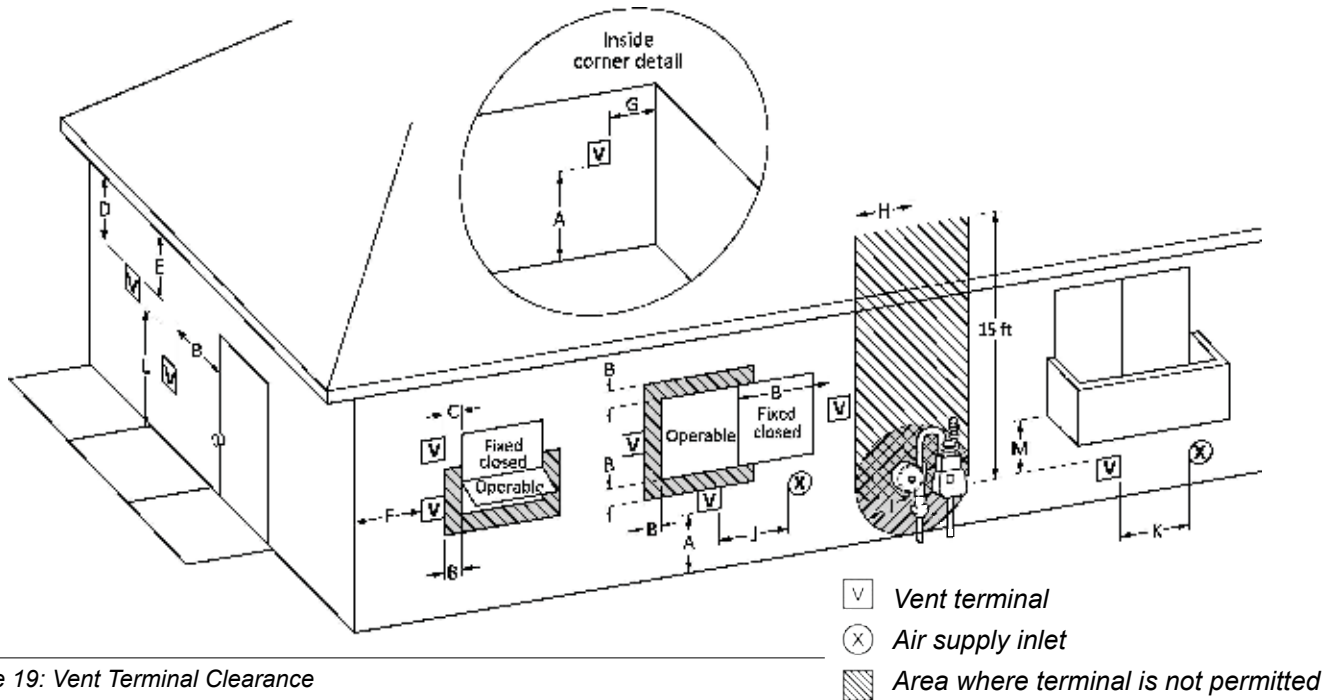

Figure 19: Vent Terminal Clearance

NOTE

Combustion air connection may be moved from one side to the other:

- Remove the retaining clip screws then lift tab at back of plug and rotate 1/8th of a turn counter-clockwise to remove from top of cabinet.
- Remove the retaining clip by removing both screws then lift tab at back of combustion air connection and rotate 1/8th of a turn counter-clockwise to remove from top of cabinet.
- Reinstall plug and combustion air connection in the desired locations then rotate 1/8th of a turn clockwise until tab latches into the top of the cabinet.
- Reinstall the retaining clip over the combustion air connection tab and secure with two screws. Reinstall two screws in the top of the cabinet near the plug.

1.4.7 “Direct Vent” Combustion Air Intake Piping

The unit must always be installed as a Direct Vent venting system with the combustion air piped directly from the outdoors to the unit’s combustion air connection. Provisions for combustion and ventilation air are in accordance with the section “Air for Combustion and Ventilation”, of the *National Fuel Gas Code, ANSI Z223.1/NFPA 54* (latest edition) in the US or Clause 8.2, 8.3 or 8.4 of *Natural Gas and Propane Installation Code, CAN/CSA B149.1* (latest edition) in Canada, or applicable provisions of the local building codes.

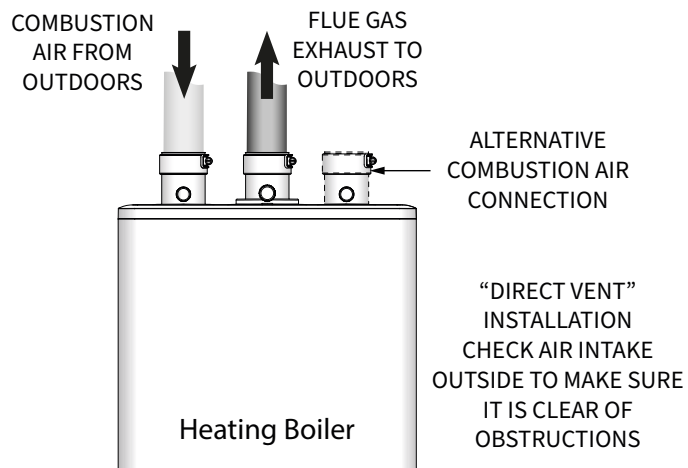

Figure 20: Direct vent combustion air intake

Intake Pipe Sizing

For 3" Flexible PPs, you can use up to 35 actual linear feet in a nominally vertical orientation (>45°). The equivalent length of 3" Flexible PPs must be calculated using a multiple of 1.4:1, e.g. 35' x 1.4 = 49' equivalent.

The balance of the venting allowance is still available for use with rigid PPs piping material.
 2" Flexible PPs is not allowed.

INTAKE PIPE SIZE/FITTINGS	MAXIMUM EQUIVALENT LENGTH
Schedule 40 PVC, ABS, CPVC or PPs – Allowances are for each side separately.	
2"	65*
3"	120'
2" or 3" 90° Long Sweep Vent Elbow	Allow 5 equivalent feet
2" or 3" 90° Short Sweep Vent Elbow	Allow 8 equivalent feet
2" or 3" 45° Vent Elbow	Allow 3 equivalent feet
PPS	
PPs 87-90° Elbow	Allow 8 equivalent feet
Flex PPS	
3" PPs Flex	35' Actual (Equivalent = Actual x 1.4)

Table 4: Maximum intake piping length.

* The input rate will derate as intake length increases. See table below for approximate derate at 2" maximum intake length.

MAXIMUM FIRING RATE	APPROXIMATE DERATE
99,000	5 - 8%
120,000	10 - 16%

For **inlet** air, you can use Schedule 40 PVC, CPVC, ABS or PPs piping of any type. Use the same diameter as vent piping.

Insert combustion air piping directly into the 2" female plastic fitting on the top of the unit, and run it horizontally or vertically to the outdoors. We recommend using a bird screen of 1/4" stainless steel or plastic mesh (eg. IPEX System 636 drain grate for CPVC systems) to guard against foreign objects.

Care must be taken to ensure adequate separation is maintained between the air intake inlet and the vent termination. Refer to the vent termination configuration drawings in the "Vent Termination" section above.

Support air intake and vent piping per local code and vent manufacturers requirements. In the absence of support requirements, support the air intake and vent piping at every vertical and horizontal transition as well as every 5' of run.

1.4.8 "Indoor Air" Combustion Air Intake

The use of indoor air for combustion is prohibited. Combustion air must be piped in from the outdoors and connected directly to the unit's combustion air connection

1.4.9 Closet Installations

For installations in a confined space (such as a closet), ventilation openings may be needed through a door or wall to prevent build-up of excessive heat from inside the space.

The unit must not be exposed to surrounding conditions above 122°F (50°C) or below 32°F (0°C).

⚠ WARNING

Fill the trap with water before initial startup of the unit to prevent exhaust fumes from entering the room. Never operate the unit unless the trap is filled with water.

Failure to comply will result in severe personal injury or death.

⚠ NOTE

It is the responsibility of the installing and/or service Contractor to advise and instruct the end user on how to perform the Trap cleaning procedure, and to advise that the trap be checked at least every two months and cleaned as required.

1.5 CONDENSATE REMOVAL

The specified vent configuration promotes the safe drainage of moisture from the unit and exhaust venting without flowing liquids back through the heat exchanger.

Reliable system operation requires (1) proper design and installation of exhaust venting to allow condensate to run back to the drain/trap; (2) acid pH neutralization as appropriate. To achieve these:

1. Allow for a 1/4" per foot slope back to the vent connection, with appropriate hangers to maintain that gradient.
2. Ensure the supplied trap is correctly installed and filled with water.
3. When required, add (and maintain in good condition) a neutralization tank.

1.5.1 Condensate Trap

The condensate trap cup must be installed on the bottom of the condensate trap at the base of the unit.

1.5.2 Installing the Condensate Trap

1. Fill the condensate trap cup with water.
2. Install the condensate trap cup on the condensate trap base and twist toward the right.
3. Attach the drain hose to the condensate trap outlet located to the left of the condensate trap cup.

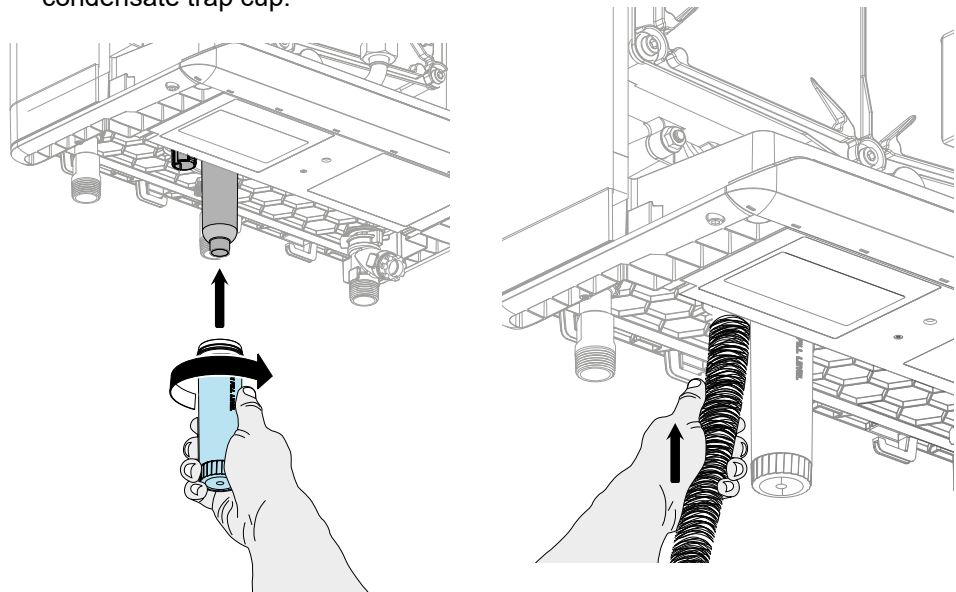

Figure 21: Condensate trap installation

⚠ DANGER

The water in the condensate neutralizer can cause severe burns to the skin. Use extreme caution when servicing the condensate neutralizer. Wear protective gloves and eyewear.

⚠ CAUTION

When a condensate neutralization package is installed, the pH of the condensate discharge must be measured on a regular schedule to ensure the neutralizing agent is active and effective.

⚠ WARNING

If discharging condensates into building drain piping materials that are subject to corrosion, you must use a neutralization package.

1.5.3 Further Installation Details

- Pipe the condensate drain tube to within 1" of a drain, or connect it to a condensate pump.
- Slope the drainage line down to the drain at a pitch of 1/4" per foot, so that the condensate runs towards the drain.
- Check the condensate trap every 2 months, and clean and refill as necessary.

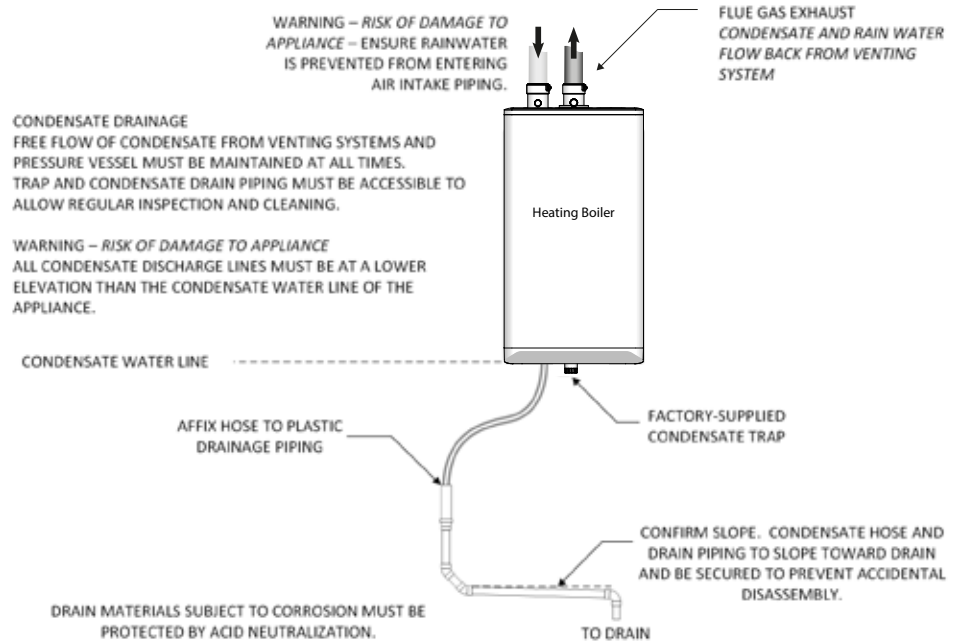

Figure 22: Condensate trap drainage

MAINTENANCE DETAILS FOR NT-1S CONDENSATE NEUTRALIZATION TANK

REFER TO MANUFACTURER'S MAINTENANCE INSTRUCTIONS FOR OTHER MAKES AND MODELS OF CONDENSATE NEUTRALIZATION TANKS.
WARNING - RISK OF INJURY
 TANK FLUID CAN BE HIGHLY ACIDIC. DO NOT USE HANDS TO STIR MATERIAL.

WARNING - RISK OF DAMAGE TO APPLIANCE
 NEUTRALIZATION TANK INLET AND DISCHARGE MUST BE AT A LOWER ELEVATION THAN THE CONDENSATE WATER LINE OF THE APPLIANCE.

NOTE - ACCESS TO THE DISCHARGE BEFORE THE DRAIN IS NECESSARY FOR PROPER MAINTENANCE IN ORDER TO CHECK THE EFFECTIVENESS OF THE NEUTRALIZING AGENT. A SIMPLE pH TEST SHOULD BE PERFORMED ANNUALLY TO ENSURE NEUTRALIZING AGENT IS STILL EFFECTIVE. IF pH FALLS BELOW 6.5 THE NEUTRALIZING MATERIAL SHOULD BE REPLACED. THE AGENT (LIMESTONE CHIPS WITH A MINIMUM CALCIUM CARBONATE CONTENT OF 85%) CAN BE PURCHASED FROM A LOCAL SUPPLIER.

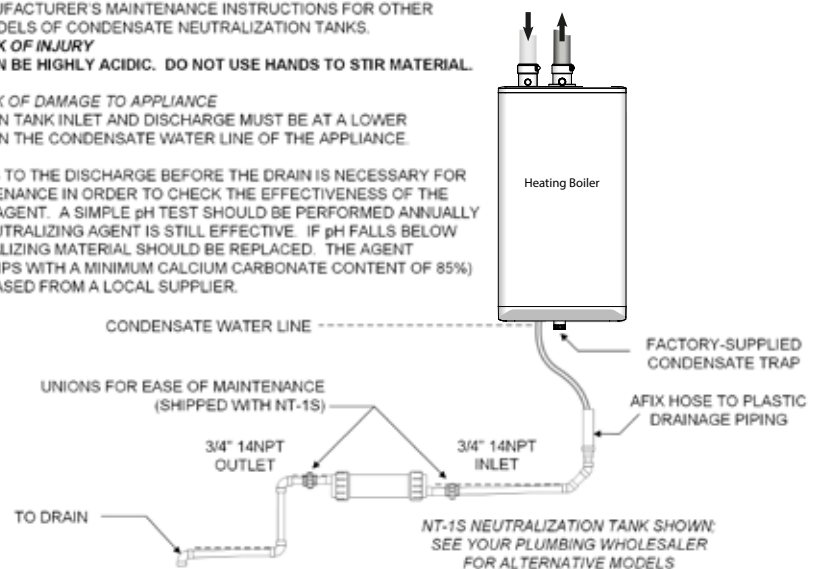

Figure 23: Condensate neutralization tank

PAGE INTENTIONALLY LEFT EMPTY

1.6 WATER PIPING - SPACE HEATING

1.6.1 General Piping Considerations

The Heating Boiler includes a factory installed, integral heating pump. The pump is designed to provide adequate flow through the unit and near unit piping.

Primary/secondary piping or the use of a buffer tank/hydraulic separator is recommended for maximum flexibility in multi zone/load applications. Piping loads in parallel is only acceptable in systems where the minimum flow rate is guaranteed to be higher than the minimum for the unit and where the unit's pump is adequate to provide the required flow rate and pump head for the system.

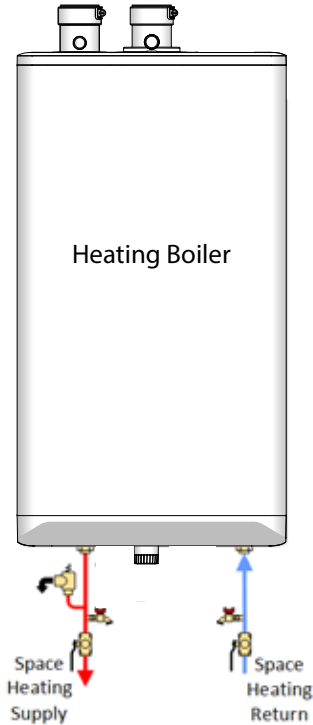
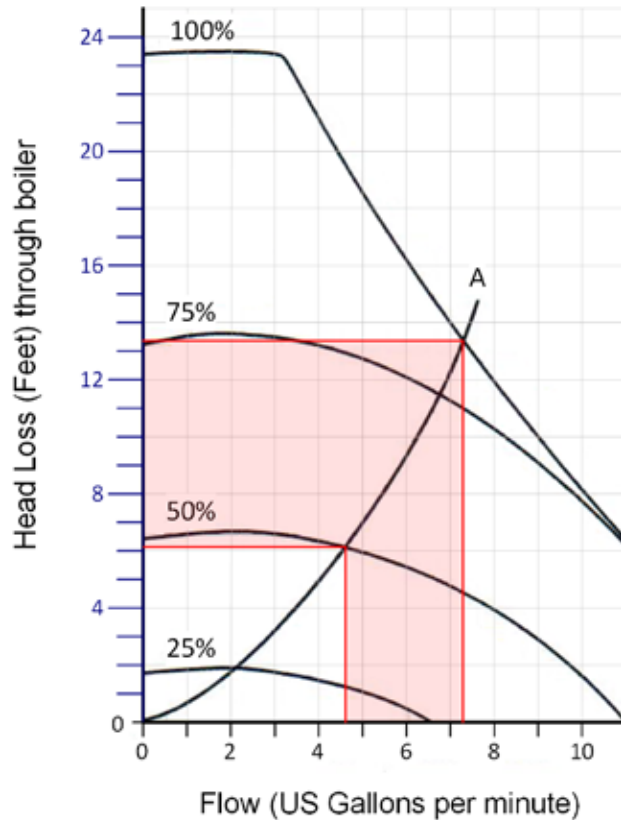

Figure 24: Overview of piping connections



Graph 1: Boiler pressure drop - Pump runs between 50% to 100% capacity to establish pressure difference across boiler circuit

A=boiler pressure drop

This unit is designed for use within a closed loop, forced circulation, low pressure system. A 30 PSI pressure relief valve (3/4" NPT) is supplied.

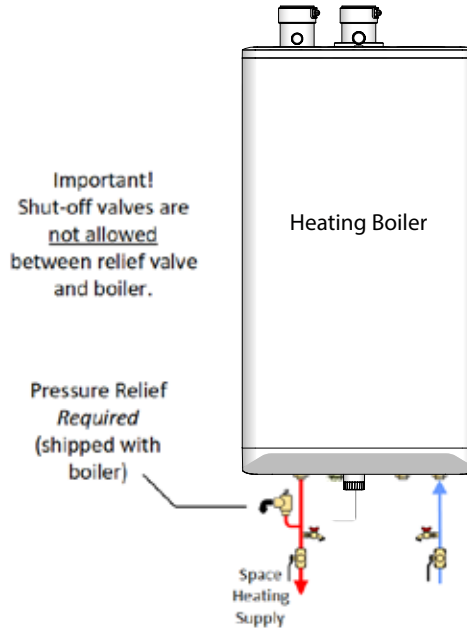

Figure 25: Relief Piping

System Piping

System piping is connected to the unit using the 1" NPT Male threaded fittings located on the bottom of the unit. Use two wrenches when tightening field piping onto the boiler. Use one wrench to hold the boiler fitting still while tightening with another wrench. We recommend using unions and gate or ball valves at the unit's supply and return water connections to simplify servicing. Un-insulated hot water pipes require a minimum 1/4" clearance from combustible materials.

Fluid fill is most often accomplished by using a regulator & fill valve set at 12 psig or more, with appropriate backflow prevention device as required by local code. This is acceptable in areas where municipal water or well water has been treated and filtered to remove excessive minerals and sediment, and water chemistry is known to be suitable for closed-loop hydronic systems. When water quality is unknown, or when chemical treatment or glycol is required, you should consider other options. Follow applicable Codes and good piping practice.

Other feed and pressurization devices on the market today may be a better choice than a raw water fill from the mains. When regular maintenance requires relief valve blow-off, the discharge may be directed back into the pressurization unit for recycling of unit fluid and chemicals back into the system. In buildings that may be unoccupied for long periods of time, pressurization units are useful to prevent flood damage should leakage occur from any component in the system. An additional benefit is that backflow prevention devices are not required when using these devices.

Do not place any water connections above the unit. Leaks can damage the fan and controls. If needed, create a shield over the top of the cover, but allow clearance for airflow and service access.

WARNING

Failure to support the boiler fitting with a second wrench while tightening field piping may lead to boiler damage.

⚠ WARNING

During operation, the relief valve may discharge large amounts of steam and/or hot water. To reduce the potential for bodily injury and property damage, a discharge line **MUST** be installed that:

1. Is connected from the valve outlet with no intervening valve and directed downward to a safe point of discharge.
2. Allows complete drainage of both the valve and the discharge line.
3. Is independently supported and securely anchored to avoid applied stress on the valve.
4. Is as short and straight as possible
5. Terminates freely to atmosphere where any discharge is clearly visible and is at no risk of freezing.
6. Terminates with a plain end which is not threaded.
7. Is constructed of a material suitable for exposure to temperatures of 375°F (190°C) or greater.
8. Is, over its entire length, of a pipe size equal to or greater than that of the valve outlet.

DO NOT CAP, PLUG OR OTHERWISE OBSTRUCT THE DISCHARGE PIPE OUTLET!

⚠ CAUTION

Installers should inquire of local water purveyors as to the suitability of their supply for use in hydronic heating systems. If water quality is questionable, a local water treatment expert must be consulted for testing, assessment and, if required, treatment.

Alternatively, water or hydronic fluid of known quality can be brought to the site.

INSTALLATION

Figure 26: Boiler trim basic options – concept drawing is only a simple schematic guide

For best results, use a primary/secondary piping system, with a boiler's loop using 1" piping (see section 1.6.2). The unit comes with the primary pump installed and generally provides adequate flow for the unit and primary loop piping only.

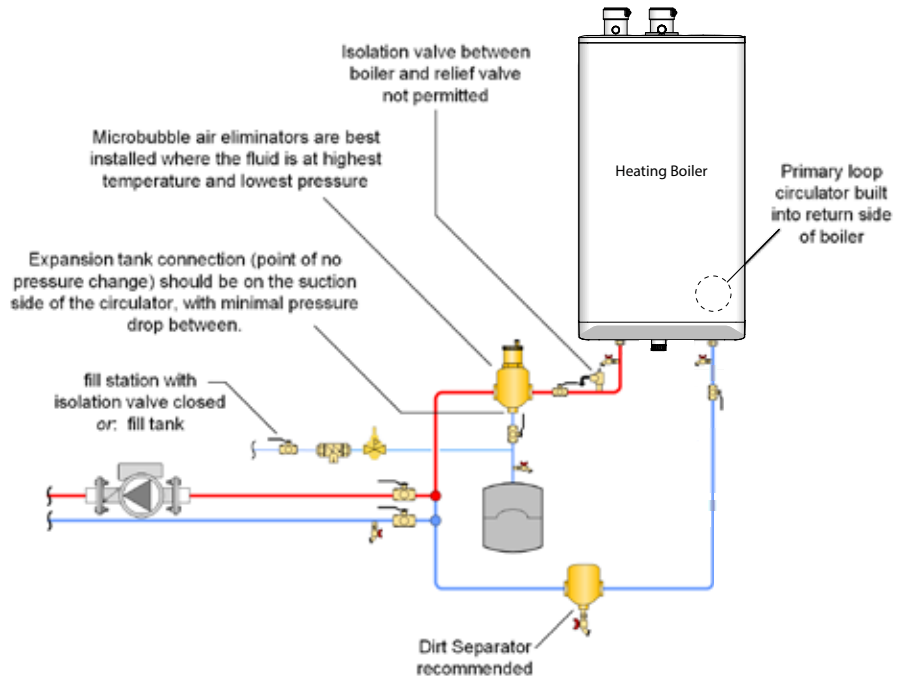
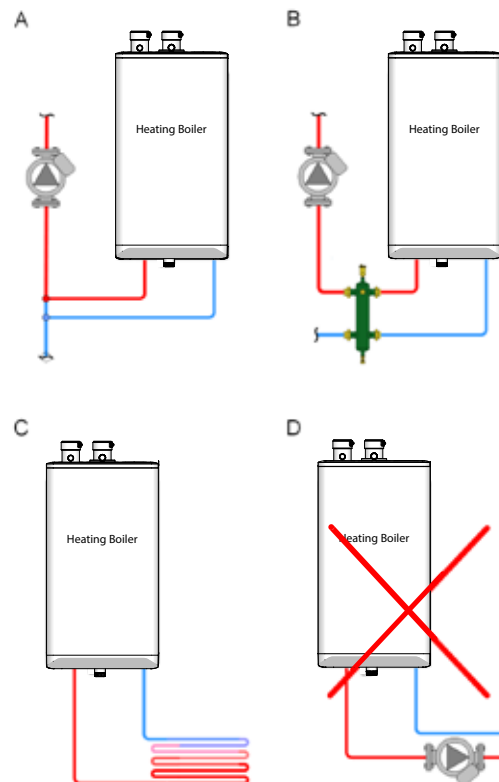

Figure 27: Permitted and prohibited space heating boiler piping

⚠ WARNING

- Close fill valve after any addition of water to the system, to reduce risk of water escapement.

- Ensure the gas ignition system components are protected from water (dripping, spraying, rain, etc.) during appliance operation and when servicing (pump replacement, condensate trap servicing, control replacement, etc.)

⚠ NOTE

- The piping system of a hot water unit connected to heating coils located in air handling units where they may be exposed to refrigerated air circulation must be equipped with flow control valves or other automatic means to prevent gravity circulation of the unit's water during the cooling cycle.

- The unit, when used in connection with a refrigeration system, must be installed so the chilled medium is piped in parallel with the unit with appropriate valves to prevent the chilled medium from entering the unit.

Figure 27 illustrates that the integral space heating pump can be hydraulically separated from the distribution pump by (A) closely-spaced tees, or by (B) a low-loss header. Although best practice is primary/secondary, in some cases (C) the integral pump will be adequate to provide flow through the building heat emitters. The installer / designer must ensure that if the integral pump is used for the space-heating emitters it is powerful enough for system distribution. Avoid (D) where an external pump is placed in series with the integral pump because the external pump runs when the Heating Boiler is serving DHW. It will strongly compromise DHW response.

The unit is designed to supply the heating load with temperatures within the range of 86°F to 194°F (30° to 90°C). Use closely-spaced tees to connect each pumped space heating load to the primary loop. As an option, a hydraulic separator or buffer tank can be used to separate the heating loads from the unit.

Ensure that the pump is rated for the design circulating water temperatures. Some pumps have a minimum water temperature rating above the low temperature potential of the unit. Following installation, confirm the performance by measuring ΔT (under high and low flow conditions) after establishing the correct firing rate.

We recommend water flow after burner shutdown to use legacy heat – this is significant due to the mass of the heat exchanger. The pump is under the control of the unit to allow pump purge after burner shut-down. Default software values will run the unit's pump for 1 minute after the burner shuts down.

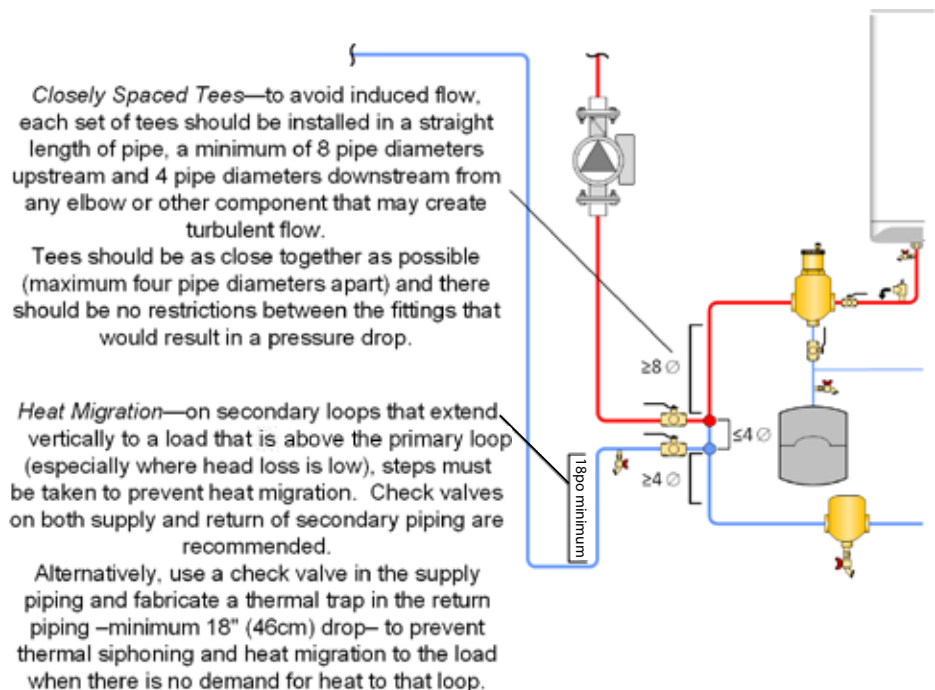

Figure 28: Basic Primary/Secondary piping with closely-spaced tees concept – concept drawing. This drawing is only a simple schematic guide.

⚠ WARNING

Water quality has a significant impact on the lifetime and performance of the unit's heat exchanger.

Improperly prepared water in a heating circuit may cause damage to the heat exchanger through corrosion or fouling. Repeated or uncontrolled water fills will increase the potential for damage.

High levels of dissolved solids or minerals may precipitate out of the fluid onto the hottest part of the heat exchanger, impairing heat transfer and resulting in overheating and premature failure. The amount of solids that may form on the heat exchanger will depend on the degree of hardness and the total water volume in the system. A high water volume system with a low hardness count may cause as much damage as a system with less volume and higher hardness. We recommend treating water to remove all dissolved solids. Other water chemistry allowable limits are as follows:

- **Acidity pH is to be between 6.5 and 8.5**
- **Chloride is to be less than 125 mg/l**
- **Iron is to be less than 0.3 mg/l**
- **Cu less than 0.1 mg/l**
- **Conductivity is to be less than 400 μ S/cm (at 25°C)**
- **Hardness is to be 7 Grains or less**

IMPORTANT: Ensure that these limits are acceptable for the other water-side components in the system.

Schematics for several piping layouts are provided herein. You must conform the piping design to one of the provided configurations to simplify the control application, promote good loads and flow management.

This unit's firing rate modulation offers exceptional matching of heat generation to radiation. The low minimum firing is better suited to low thermal loads presented in a typical multi-zoned radiation system. However, where individual zones in a heating system have loads under 10,000 Btu/hr, the system will still benefit through the use of a buffer tank to ensure a controlled supply temperature, and to prevent short-cycling. Buffering should be added on the secondary piping of the relevant load, to avoid bulking up the thermal mass of the primary piping circuit (and potentially lengthen the duration of the transition from hot to cool loads).

Propylene glycol solution is commonly used in a closed loop where freeze protection is required. Its density is lower than that of water, resulting in lower thermal performance at a given flow and pressure. A solution of propylene glycol and water will require an increased system circulation rate and system head to provide performance equivalent to straight water.

1.6.2 Basic Heating Piping Arrangements

Primary/Secondary Piping - Benefits and installation rules

The primary/secondary configuration:

- Ensures good circulating water flow through the unit irrespective of load or radiation system head.
- Allows flexible ΔT° control in secondary loops.
- Adds to the system's thermal buffering, to assist in handling small loads and temperature transition.

A primary/secondary piping configuration requires an extra pump, independent of any secondary load pumps. The Heating Boiler includes a pre-wired integral Primary Pump.

For optimal performance, place pumps on the supply side of secondary loops to facilitate air evacuation. Use pumps with internal check valves to avoid ghost flows and thermal siphoning.

The unit is designed to be piped in a primary/secondary piping arrangement. In some cases the unit can be piped in series with the heating load if the pump is capable of providing the flow and head the system requires. For example, this unit and an air handler can be installed together without the use of an additional pump if the air handler is installed within close proximity of the unit and with properly sized supply and return piping (see *Figure 33*).

If the installation involves small loads, as in typical zoned baseboard heating applications, we recommend using a buffer tank.

To aid in temperature transition from hot to cool loads, place a 3-way mixing valve at the entrance to the cool load (this will also provide floor protection). This type of installation allows immediate circulation of mixed flow into the cool loop.

⚠ WARNING

Do not use automotive-type ethylene or other types of automotive glycol antifreeze, or undiluted antifreeze of any kind. This may result in severe unit damage. It is the responsibility of the Installer to ensure that glycol solutions are formulated to inhibit corrosion in hydronic heating systems of mixed materials. Improper mixtures and chemical additives may cause damage to ferrous and non-ferrous components as well as non-metallic, wetted components, normally found in hydronic systems. Ethylene glycol is toxic, and may be prohibited for use by codes applicable to your installation location. For environmental and toxicity reasons, we require only using non-toxic propylene glycol.

⚠ NOTE

- The piping drawings in this manual are simple schematic guides to a successful installation.
- There are many necessary components not shown, and details such as thermal traps are left out so the drawings have greater clarity.
- We require that our units be installed by licensed and experienced trades people who are familiar with the applicable local and national codes.
- System design is to be completed by an experienced hydronic designer or Engineer. It is necessary to carefully read and follow these installation instructions along with the application drawing that fits your system.

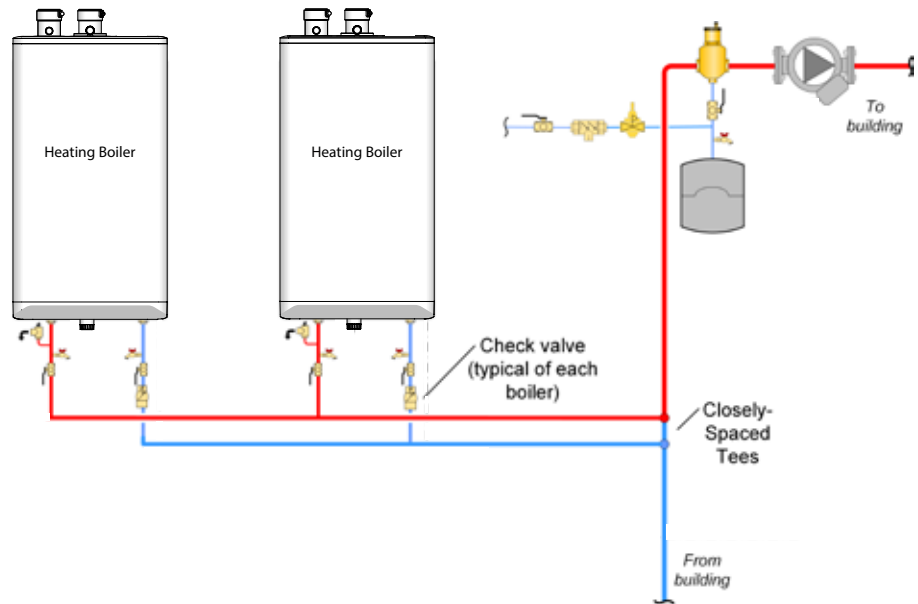

Figure 29: Multiple boiler piping concept – concept drawing. This drawing is only a simple schematic guide.

Multiple unit piping - Benefits and installation rules

Multiple Heating Boilers can be installed in a single heating system to provide redundancy, increased output, and greater heating plant turn-down capabilities. Primary/Secondary piping must be used. This approach provides constant head and flow at each unit, regardless of flow variations in the main building loop.

Each unit controls its own pump, turning it off or on when heat is required. This approach saves electricity by reducing the pumping power required as load conditions are reduced.

The Heating Boilers controller includes a cascade function which allows up to 8 Heating Boilers or Combi Boilers to operate together to satisfy a common demand. See included Controller Manual for details.

Use check valves in each unit's piping to prevent reverse flow when the unit is off.

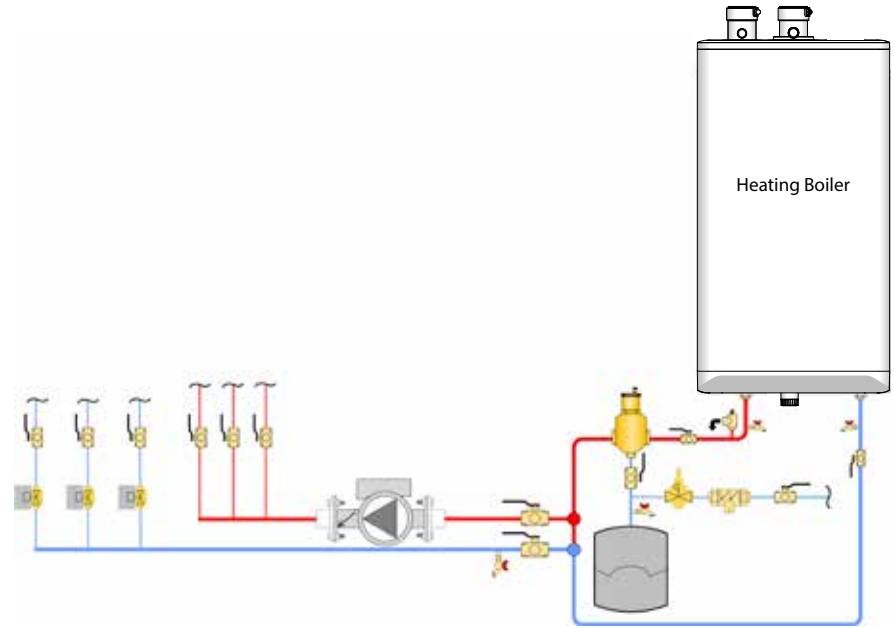

Figure 30: Typical one temperature space heating piping concept. This drawing is only a simple schematic guide.

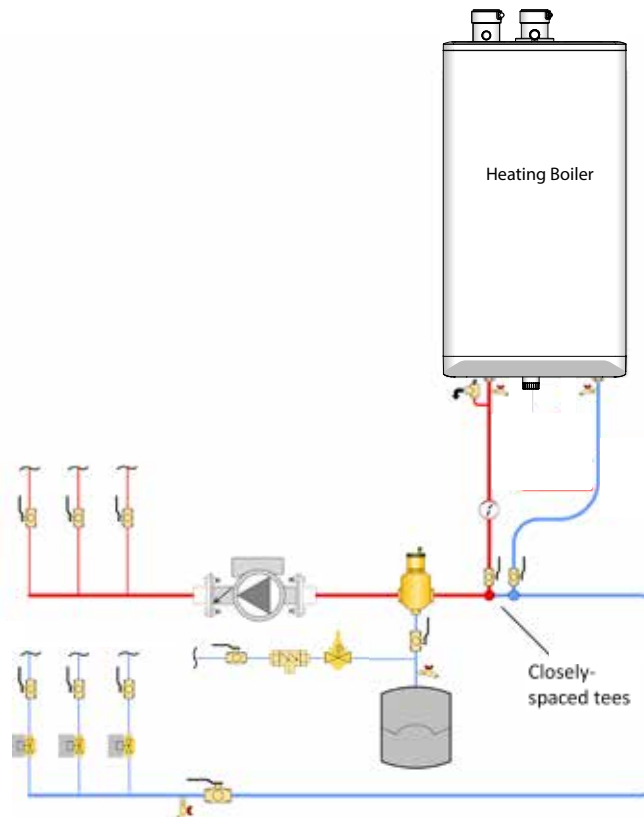

Figure 31: Space heating piping concept with closely-spaced tees on secondary loop.

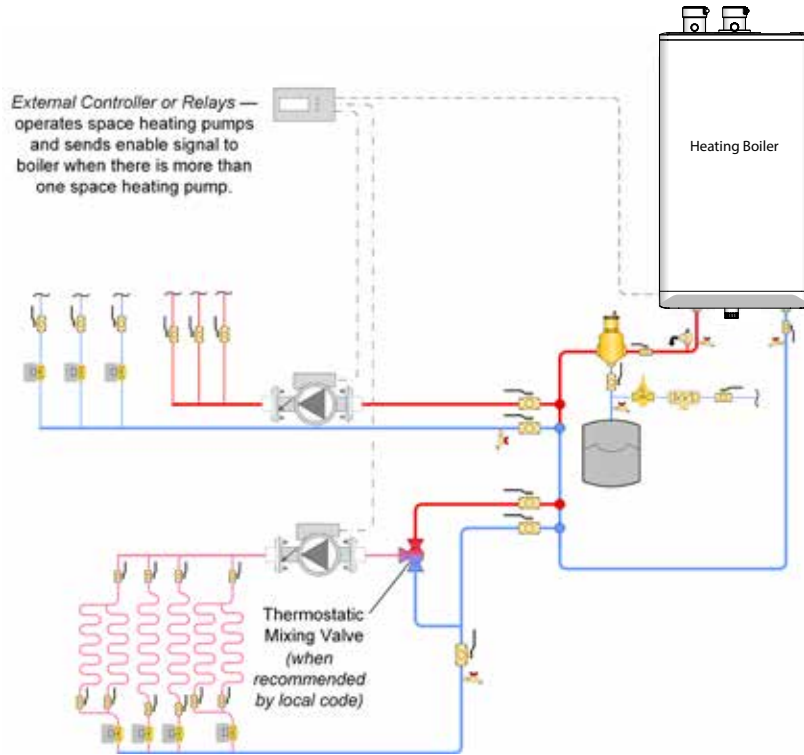

Figure 32: Typical two temperature space heating piping concept. This drawing is only a simple schematic guide.

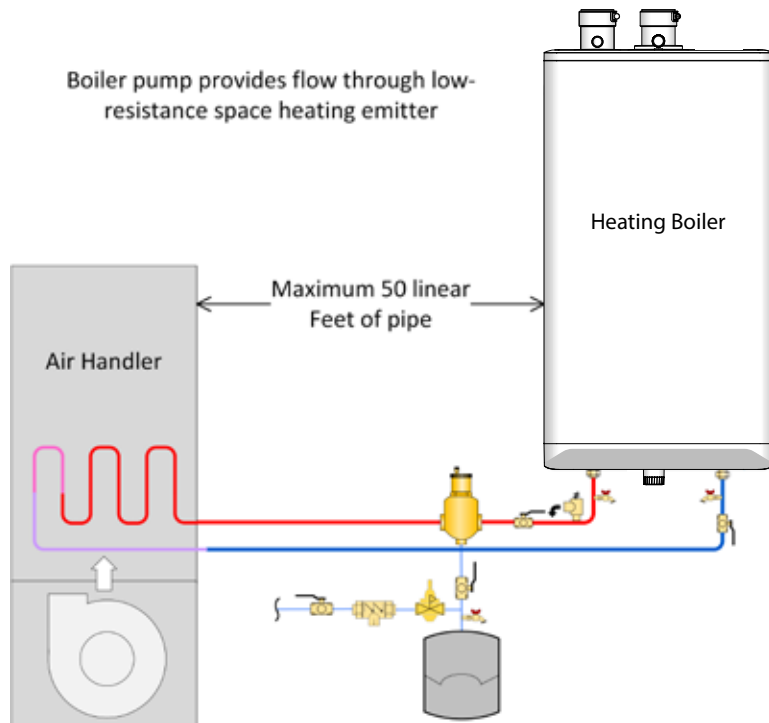

Figure 33: Air handler – parallel piping for low loss heat emitter concept drawing. This drawing is only a simple schematic guide.

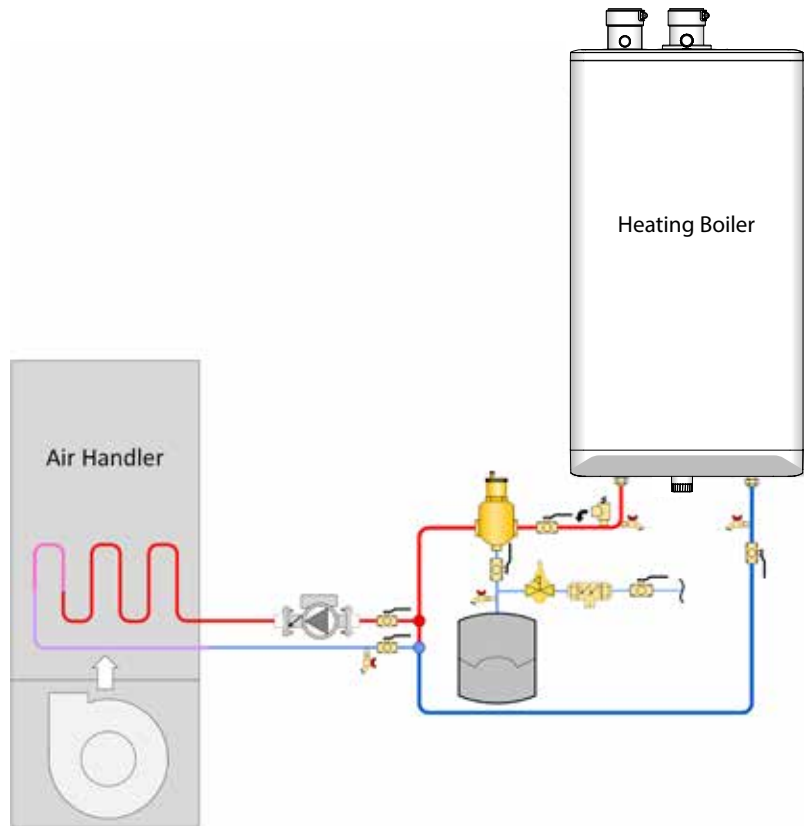

Figure 34: Air handler – primary/secondary concept drawing. This drawing is only a simple schematic guide.

⚠ WARNING

Failure to support the boiler fitting with a second wrench while tightening field piping may lead to boiler damage.

⚠ WARNING

This boiler model can burn either natural gas or propane. Refer to section 3.3 for further instruction. If converting a unit from one fuel to another, you must order a conversion kit prior to the conversion. Install the conversion kit according to the detailed instructions supplied with the kit. Failure to perform the required fuel conversion correctly can result in serious injury or death.

⚠ NOTE

It is essential to check gas supply pressure to each unit with a manometer or other high-quality precision measuring device. Pressure should be monitored before firing the unit, when the regulator is in a “lock-up” condition and during operation, throughout the unit’s full modulation range.

Pay special attention to retrofit situations where existing regulators may have an over-sized orifice and/or worn seats, causing pressure “creep” and high lock up pressures.

⚠ WARNING

Do not check for gas leaks with an open flame, use the bubble test. Failure to use the bubble test or check for gas leaks can cause substantial property damage, serious injury, or death.

1.7 GAS PIPING

The unit must have an inlet gas pressure of at least 4.0" w.c. for natural gas and propane. For either fuel, the inlet pressure shall be no greater than 14.0" w.c. Confirm this pressure range is available with your local gas supplier.

The inlet gas connection of the unit’s gas valve is 3/4" NPT (male). Use two wrenches when tightening field piping onto the boiler. Use one wrench to hold the boiler fitting still while tightening with another wrench.

Adequate gas supply piping must be provided with no smaller than 1/2" Iron Pipe Size (IPS) and a 1" w.c. pressure drop, in accordance with the following chart:

MODEL	1/2" IPS	3/4" IPS	1" IPS
99,000 Btu/hr (Natural Gas)	40'	175'	500'
120,000 Btu/hr (Natural Gas)	30'	100'	350'
99,000 Btu/hr (Propane)	100'	450'	1,400'
120,000 Btu/hr (Propane)	80'	300'	1,000'

Table 5: Maximum Pipe Length (ft)

Gas piping must have a sediment trap ahead of the unit’s gas valve (see Figure 36). A manual shutoff valve must be located outside the unit, in accordance with local codes/standards. All threaded joints in gas piping must be made with an approved piping compound resistant to the action of natural gas/propane. Use proper hangers to support gas supply piping as per applicable codes.

Before placing the boiler into operation, the boiler and all gas connections must be checked for leaks.

- Close the gas shutoff valve during any pressure testing equal to or less than ½ psi (3.5 kPa).
- Disconnect the boiler and gas shutoff valve from the gas supply during any pressure testing greater than ½ psi (3.5 kPa).

The gas valve is provided with pressure taps to measure gas pressure upstream (supply pressure) and downstream (manifold pressure) of the gas valve (see Figure 35). Note that manifold pressure varies slightly in accordance with firing rates with the modulating series units, but will always be close to 0" w.c.

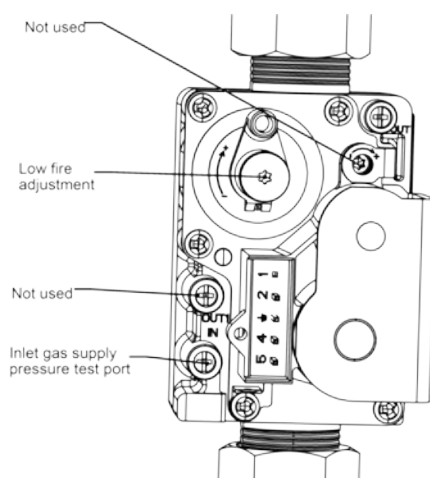

Figure 35: Gas Valve



Figure 36: Gas Piping

⚠ WARNING

Do not apply power to any connection point on the controllers terminal strips. A hazardous situation could occur resulting in possible serious injury or death.

1.8 ELECTRICAL CONNECTIONS

Electrical wiring to the unit (including grounding) must conform to local electrical codes and/or National Electrical Code, ANSI/NFPA No. 70 – latest edition in the US or The Canadian Electrical Code, C22.1 - Part 1 in Canada.

1.8.1 120VAC Line Voltage Hook-up

(Refer to Section 6.2. Wiring Diagram on page 6-5). Connect the unit to the grid power, using the supplied appliance plug in a separate non GFCI fused circuit and on/off switch within sight of the unit.

The unit is equipped with 3 x 1/2" electrical knock-outs for control wiring located behind the power supply terminal strip.

The unit includes a factory installed and pre-wired pump. The pump may not be able to supply adequate flow for the heat emitter circuits. A system heating pump switched through a separate relay or control box may be needed.

1.8.2 Accessing Controller Terminal Strip

Pull out on the two control module retaining tabs then flip down the control to access the terminal strip.

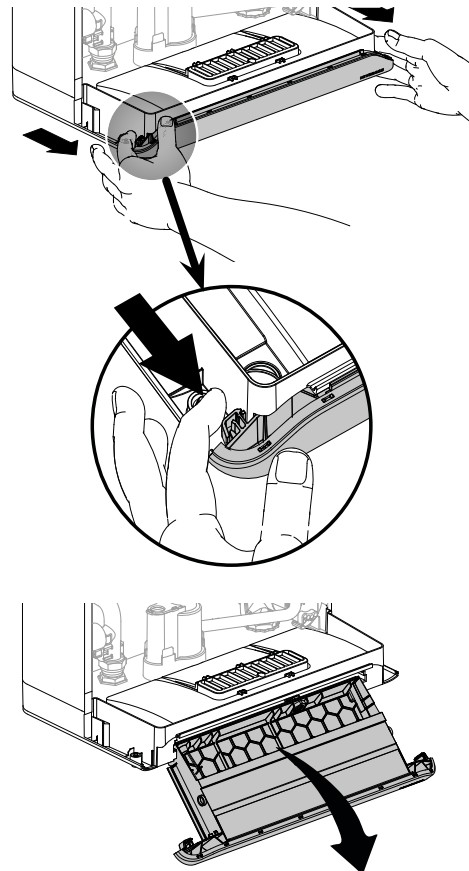

Figure 37: Pulling out the tray

NOTE

- This unit (like any modern appliance that contains electronic equipment), must have a “clean” power supply, and can be disabled by power surges and spikes, lightning strikes and other forms of severe electrical “noise”. Power conditioning equipment (surge protectors, APC or UPS devices) may be required in areas where power quality is suspect.

- The control typically uses a true dry contact closure as a call for heat. A signal from an Open Therm device can also be used. Thermostats and other devices that use a “Triac” output cannot be used as a call for heat without the installation of an intervening relay with dry contacts to connect to the terminal strip.

- A Heating Boiler installed above radiation level or as required by the Authority Having Jurisdiction, must be provided with a low water cut-off device at the time of unit installation. Refer to 1.8.3 External probe type low water cutoff device for installation instructions.



Figure 38: Junction Box

Field Wiring Junction box

The unit ships with an optional field-wiring junction box. This box provides wiring connections for a space-heating pump, a DHW pump, and an outlet for unit power. A certified harness from the wiring box connects to the movable controller tray. You do not require a junction box if:

1. External pumps do not need to be controlled for space heating
2. There are no DHW indirect or storage tanks.

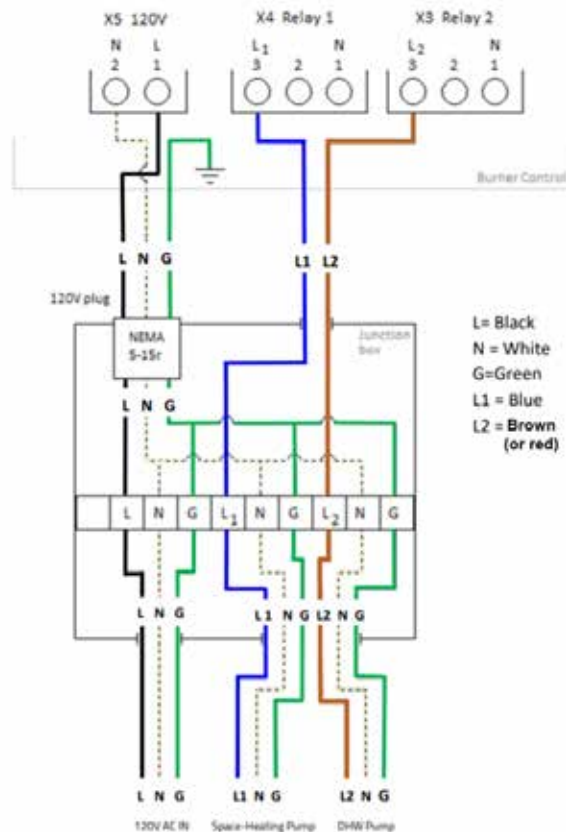

Figure 39 Junction box schematic

To install an external junction box to supply power and access the two pump relays:

1. Pull out the controller as shown in Figure 37.
2. At the back of the tray, knock out the hole nearest to the power cord using a flathead screwdriver.
3. Feed the junction box cable through the hole and secure to the tray with the connector nut.
4. Connect the blue wire to the X4 terminal, position 3.
5. Connect the brown (or red) wire to the X3 terminal, position 3.
6. Screw the junction box to the wall within six feet of the tray.
 - Allow clearance for plug use.
 - Allow wire enough slack for easy removal of the tray.
7. Drill out both holes in the junction box.
8. Connect 120VAC power to terminals labelled **Power Inlet**.

9. Wire the pump(s) to the junction box.

- Wire the space heating pump to terminals labeled **Relay 1**.
- Wire the DHW pump to terminals labeled **Relay 2**.

If using both relays, wire the pumps to the box with a duplex connector.

10. Install the junction box cover.

Note: If the junction box is installed, 120VAC power must be supplied to the Heating Boiler through the junction box. Do not plug the unit in elsewhere.

1.8.3 External probe type low water cutoff device

You can link a field-supplied, external safety device to the unit by connecting the safety device in series with the unit's 120V main power supply.

We recommend using an electronic probe style device:

- Install the probe type low water cut-off device with a Tee connection at a level above the top of the unit.
- Wire the probe type low water cut-off device in series with the 120VAC power supply, so that when the device trips on a low water condition the power supply to the unit is interrupted.

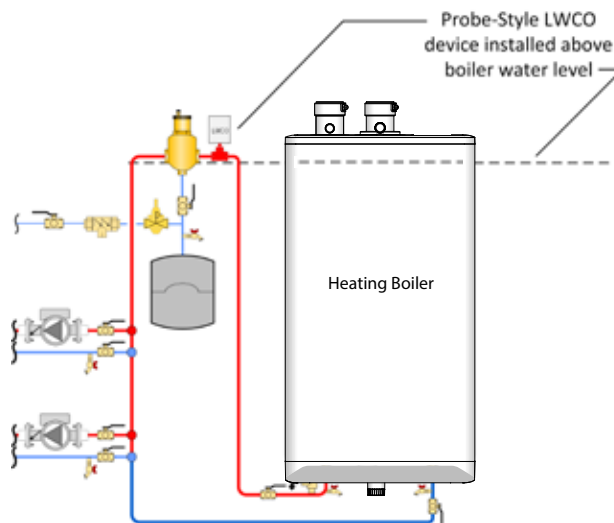

Figure 40: External Probe Type Low Water Cutoff Device

1.8.4 Power Quality and Electrical Protection

In areas of unreliable power, appropriate surge protectors and / or power conditioning equipment should be installed to protect the unit.

1.8.5 Zone Valve and Zone Pump Connections

Zoning can be accomplished with either zone pumps or zone valves. If zoning by multiple pumps, we recommend using an external pump module.

Zone valve end switches can be wired together in parallel, and connected to X13 terminals 1 and 2. Do not apply power to the X13 terminal strip. Alternatively, you can connect the zone valves and thermostats to a zoning panel control system (available from your local heating wholesaler).

You can connect zone pumps to the unit with a zone pump control, available from your local heating wholesaler.

1.8.6 Thermostat / Sensor Wiring

A thermostat from a single zone heating system can be connected directly to the controller's X13 terminals 1 and 2. Do not apply power to the X13 terminal strip.

An outdoor sensor is not required for the unit to operate. If an outdoor sensor is not connected, the unit will operate as a set point unit and operate at its design supply temperature.

If outdoor reset functionality is desired connect the supplied Outdoor sensor to X13 terminals 3 and 4. The outdoor sensor is a 12KΩ thermistor type sensor.

The sensor should be installed:

- On the exterior of the building on the north side.
- Ensure the outdoor sensor is shielded from direct sunlight and not near any building exhausts which could affect its temperature reading.

DHW Aquastat or 10KΩ sensor can be connected to the controller's X13 terminals 4 and 5. Do not apply power to the X13 terminal strip.

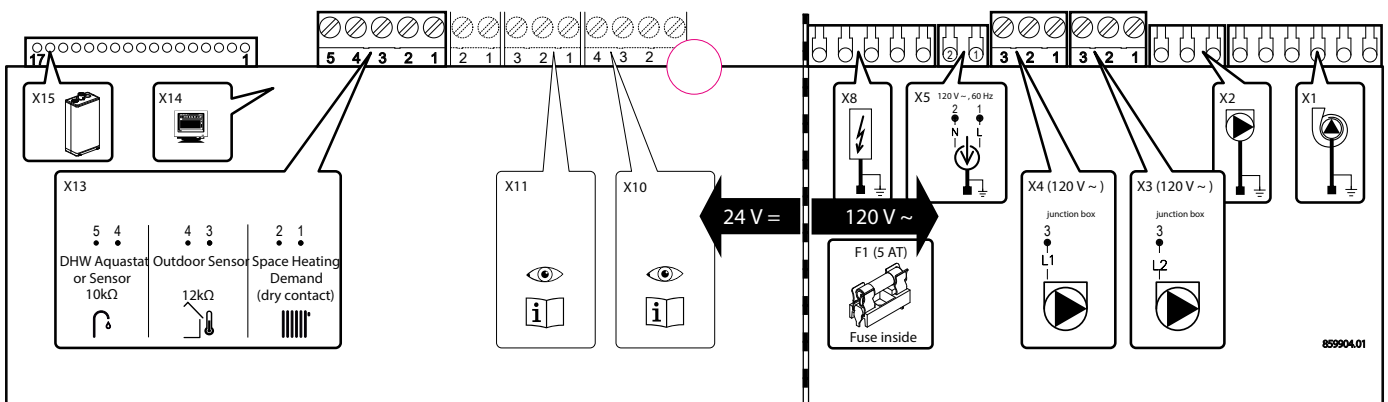

Figure 41: Terminal strip for connection of the DHW Aquastat (optional), thermostat or end switch(es) (mandatory), outdoor sensor (optional)

2.0 UNIT SYSTEM OPERATION

2.1 GENERAL

The Heating Boiler is designed to heat your indoor space. The Heating Boiler units can also generate domestic hot water with an indirect water heater.

With the installation of the provided outdoor sensor, the unit's controller can provide outdoor reset control for the space heating load. Installing the outdoor sensor is optional, but recommended for higher efficiency.

Alternatively, the controller can provide a set-point water temperature for the space heating load.

The unit is equipped with a factory-installed pump. The pump is pre-wired and will operate with any call for space heating or when heating an indirect water heater.

The Heating boiler pump operates for 10 seconds every 24 hours to prevent it from seizing. The pump is energized 24 hours after the last call for heat and every 24 hours after that until the next call for heat.

The unit is equipped with an electronic unit controller that ignites the burner and continuously monitors the flame throughout each call for heat. The control also displays the current operating conditions of the unit and any error messages should a problem occur.

The unit's controller also provides frost protection. When the unit's heat exchanger temperature becomes too low the burner switches on to keep the heat exchanger warm. Ensure that the condensate trap is protected from freezing. The unit must be installed indoors.

2.2 CONTROL

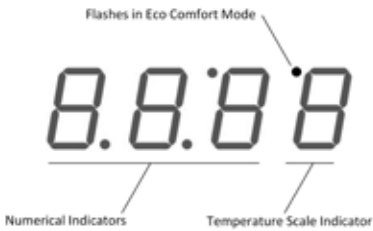
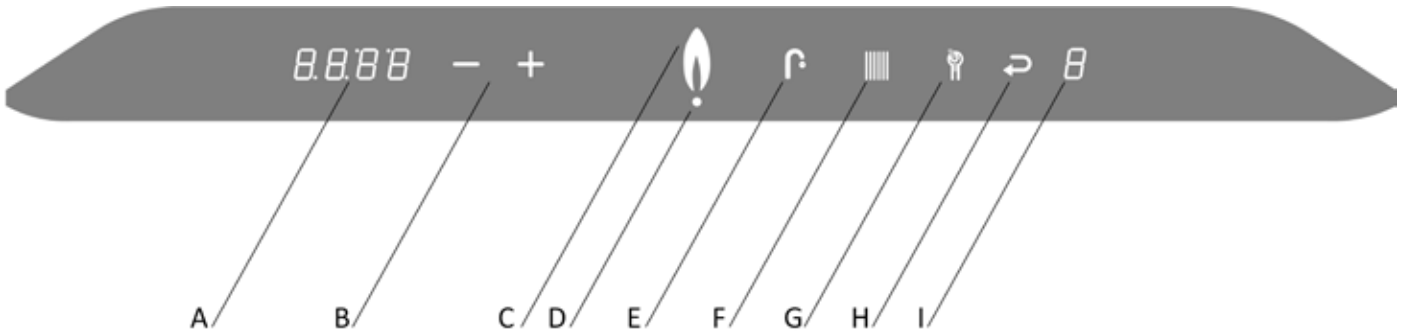

ICON	FUNCTION	
A	Numerical Display	Main Display
B	Plus & Minus	Temperature Adjustment
C	Flame	Burner ON Indicator
D	Dot	Power ON Indicator
E	Faucet	DHW Indicator
F	Radiator	Heating Indicator
G	Wrench	Service / Reset
H	Return Arrow	Enter / Save
I	Numerical Display	Service Display

Table 6: Controller Indicators and Touch Pad

2.3 INSTALLER INTERFACE

2.3.1 Turning Appliance ON/OFF

To turn on the unit, touch the area above the dot for 2 seconds. Now only the dot is illuminated.

To turn off the unit, touch the area above the dot for 2 seconds. A dash appears to the right and the space heating water pressure displays to the left.

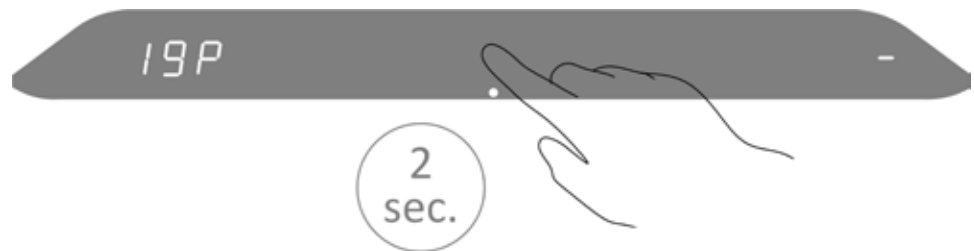

2.3.2 Programming Mode

There are two parameters available in the User Setup Menu.

The controller has five levels: User Menu, Installer Menu (code 15), a Master Installer Menu (code 20), RF Menu (code 30) and Cascade Menu (code 35). See *included Controller Manual for details*.

Adjusting the space heating water temperature

To access the main menu:

1. Touch the area above the dot.
2. Touch the Radiator button.



3. To change the space heating target temperature, touch the Plus or Minus buttons.

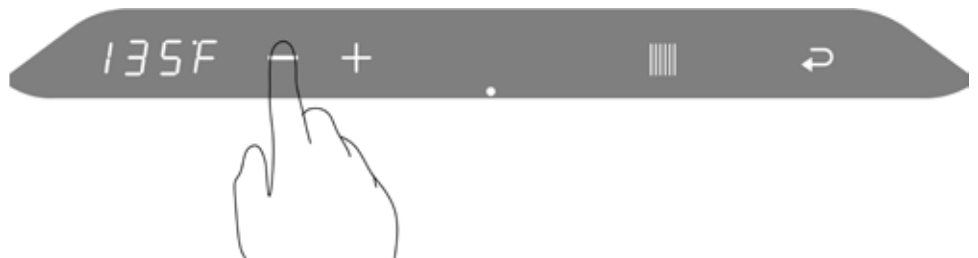

4.

- To save the changes, touch the Return button.
- To exit without saving the changes, touch the area above the dot.



"P" to the right of the screen indicates that the changes have been saved.



⚠ WARNING

The correct 10KΩ temperature sensor (or aquastat) must be used to operate the indirect water heater properly. If the incorrect sensor is used the domestic hot water may overheat causing serious injury or death.

Adjusting the Domestic Hot Water Temperature

This setting takes effect only when the temperature of an indirect domestic hot water heater is sensed by a 10KΩ DHW sensor.

To access the main menu:

1. Touch the area above the dot.
2. Touch the Faucet button.

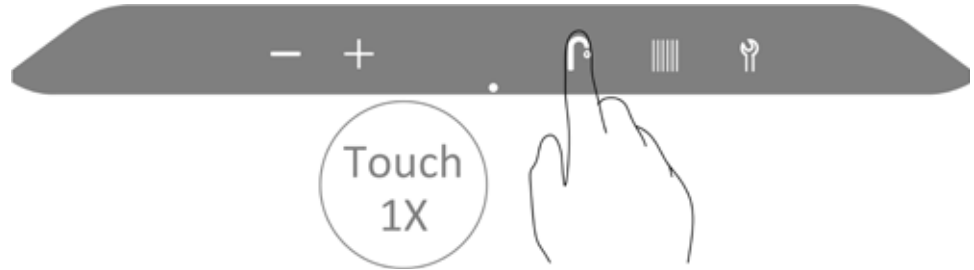

3. To change the DHW target temperature, touch the Plus or Minus buttons.



- 4.

- To save the changes, touch the Return button.
- To exit without saving the changes, touch the area above the dot.



“P” to the right of the screen indicates that the changes have been saved.



2.4 DOMESTIC HOT WATER

2.4.1 Domestic Hot Water with an Indirect Water Heater

You can connect the Heating Boiler to an indirect water heater. Connect the indirect water heater's supply and return connections to the unit's primary loop using a hydraulic separator or closely-spaced tees. Properly sized piping must be installed. A properly sized pump must also be installed between the unit and the indirect water heater. The pump can be wired to the included junction box to provide DHW priority.

2.5 SPACE HEATING

2.5.1 Overview

The Heating Boiler is designed to be installed in a primary/secondary type piping system. The unit comes complete with a factory-installed pump, which is designed to circulate heating system water through the unit's heat exchanger and primary loop piping only. The building's distribution piping system may require a dedicated pump or pumps to circulate space heating water through the heating system. The unit can operate a separate building pump (120V 1.0 AMP max).

There are various ways to zone a space heating system. Local wholesalers sell control packages that offer easy methods to connect the zoning system to the unit.

The unit supplies heat to the space using an outdoor reset function. With an outdoor sensor installed, the unit automatically adjusts its space heating water temperature based on the parameters programmed into the unit. *See separate controller manual for parameter information.* If the Outdoor sensor is not installed, the unit uses the temperature set in the "User Set Up" menu "Boiler Supply Temperature" to supply hot water to the space heating system.



NOTE

The unit is equipped with a frost protection feature. This feature operates the unit's built-in pump and the burner to help protect the unit from freezing. If the unit is in a hard lock-out condition the burner will not operate, but the unit's built-in pump will operate. We are not responsible for damages to the unit, and/or related components, nor property damages that may result from freezing conditions.

2.6 SEQUENCE OF OPERATION

The unit operates in a similar way for both a space heating and a domestic hot water call for heat. When the unit is powered up the controller enters a self-diagnostic mode, and displays the controller software version in the main display.

The sequence of operation is as follows:

1. The unit receives a call for heat from a dry contact closure on terminals X13.1 and X13.2 (24 volts section). The unit can also receive a call for domestic hot water heating from a 10K Ω sensor or aquastat wired to terminals X13.4 and X13.5 (24 volts section).
2. The unit performs a safety check and energizes the fan for a pre-purge (*Service Display = 3*).
3. Once the 5-second pre-purge is complete, the unit enters a 5-second trial for ignition (*Service Display = 4*). If the unit fails to ignite, the unit will complete another 5-second pre-purge then 5-second trial for ignition. This is repeated 4 times before a hard lock-out occurs. The Return button must be pressed to reset the controller and begin another trial for ignition.
4. Once the burner is lit and flame has been proven the unit operates as it is programmed (*Display =*  for space heating or  for domestic hot water).
5. If the unit exceeds its target temperature and there is still a call for heat or hot water the burner will turn off (integral pump runs) (*Service Display = 1*).
6. After call for heat is satisfied, the unit's pump will operate for an adjustable amount of time (*Service Display = 0*).
7. If the burner is on for frost protection (*Service Display = 9*).





MAIN DISPLAY	SERVICE DISPLAY	DESCRIPTION
[pressure] P	-	The unit is OFF. Press the space above the dot for 2 seconds to turn on the unit.
(blank)	(blank)	No Call for Heat - Standby
XXX	0	Unit pump running – pump post purge
XXX	1	Unit water temperature exceeds target – unit pump is energized, call still present
XXX	2	Self-test – When power is applied to the unit the controller enters a self diagnostic mode for 5 seconds
XXX	3	Fan Pre-purge and Post-purge
XXX	4	Trial for Ignition and Flame Proving
XXX	 + 	Heating – Space Heating
XXX	 + 	Heating – DHW
XXX	7	Burner on for DHW Comfort mode
XXX	9	Freeze Protection mode

Table 7: Operating Display and Service Display Codes.

2.7 ACCESSING THE INFORMATION MENU

The Information menu provides real time operating information to assist with troubleshooting.

To access the Information menu:

1. Touch the area above the Dot.
2. Touch and hold the Wrench button for two seconds, let go when the minus, plus, and wrench are displayed.



3. Again, touch and hold the Wrench button for two seconds to enter the information menu.

See table 8 for a list of codes and corresponding description.

4. To scroll through the list of codes, use the Minus or Plus button.
5. To exit the information menu and return to the Service menu, press the area above the Dot.

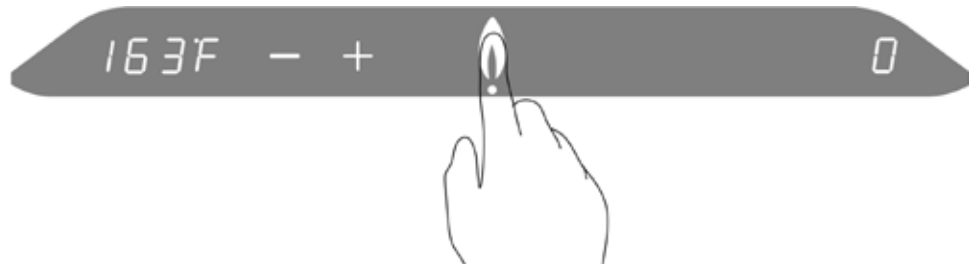

See below for a description of the codes:

CODE	DISPLAY	EXAMPLE
A	Flame current in μ A	9.80A
b	DHW flow in L/min or Gallon/min tankless/combi models only	0.98
C	Boiler system pressure boiler models only	118P
F	Estimated power input in kW or MBH	116
n	Space heating setpoint	110F
P	Actual pump speed in % boiler models only	42
t	Last lock-out code	F031
=	Main processor software	1.60
=	DSP software	1.20
0	Temp. S0 (Heat Exchanger)	134F
1	Temp. S1 (Boiler Supply)	118F
2	Temp. S2 (Not Applicable)	--F
3	Temp. S3 (Domestic Hot Water)	125F
4	Temp. S4 (Domestic Cold Water)	50F
5	Temp. S5 (Flue)	142F
6	Temp. S6 (Outdoor) - optional	17F
7	Temp. S7 (DHW tank) - optional	124F
r	Cascade Communication	442

Table 8: Information Menu

Note that display parameters may differ depending on the configuration. Where there is no DHW sensor, the display reading can be ignored.

⚠ CAUTION

The maintenance counter must only be reset after performing the maintenance procedures in Section 4.0 Maintenance of this manual. Failure to perform maintenance can result in a hazardous condition.

2.8 RESETTING THE MAINTENANCE COUNTER

Inspection of the unit must be performed annually by a qualified service technician. This unit includes a maintenance counter which tracks the amount of fuel burned within a two year period to ensure maintenance is performed if usage exceeds typical residential usage. When above average usage occurs within a two year period, a notification code will be displayed.

To reset the maintenance counter and clear a maintenance notification code:

1. Touch the area above the dot.

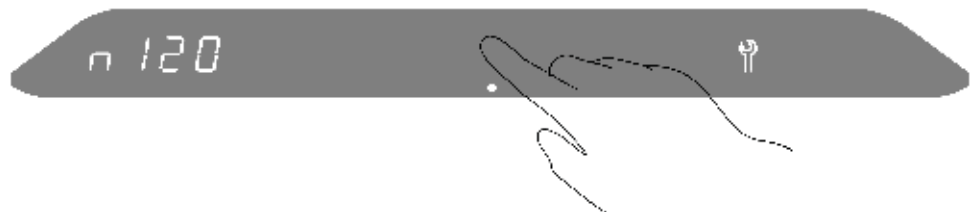

2. Touch the wrench for two seconds until the return button appears.



3. Touch wrench and return buttons together.



The code numbers are displayed in the left numerical display.



4. Change C000 to C090 by touching the + button.

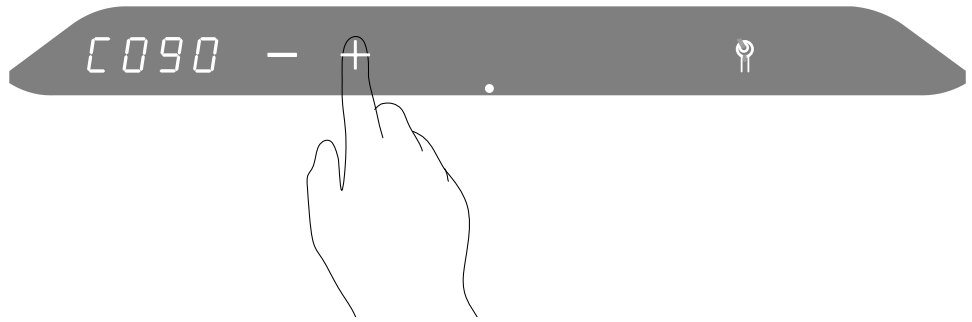

5. Touch wrench to enter the maintenance menu.



The current maintenance counter value is displayed in the left numerical display.



The following notifications will be displayed as the time for maintenance approaches.

MAINTENANCE COUNTER	NOTIFICATION CODE
80	n120 - Maintenance recommended
100	n121 - Maintenance required, limited DHW output
120	n122 - Maintenance required, no DHW output

The notification code will be displayed for 30 seconds and the wrench will flash. Press the wrench button to see the notification code again after 30 seconds.

6. Touch the wrench to reset the maintenance counter to "0".



7. Touch return to resume normal operation.



"P" will be briefly displayed on the right screen to indicate the change has been stored.



This page is intentionally left blank.

3.0 STARTUP & COMMISSIONING

3.1 LIGHTING & SHUTTING DOWN THE UNIT

FOR YOUR SAFETY READ BEFORE OPERATING

WARNING: If you do not follow these instructions exactly, a fire or explosion may result causing property damage, personal injury or loss of life

- A. This appliance does not have a pilot. It is equipped with an ignition device which automatically lights the burner. Do not try to light the burner by hand.
- B. **BEFORE OPERATING** smell all around the appliance area for gas. Be sure to smell next to the floor because some gas (LP) is heavier than air and will settle on the floor.
- WHAT TO DO IF YOU SMELL GAS**
- Do not try to light any appliance.
 - Do not touch any electric switch; do not use any phone in your building.
 - Immediately call your gas supplier from a neighbor's phone. Follow the gas supplier's instructions.
- If you cannot reach your gas supplier, call the fire department.
- C. Use only your hand to turn the gas control valve. Never force using tools. If the valve will not turn by hand, don't try to repair it, call a qualified service technician. Force or attempted repair may result in a fire or explosion.
- D. Do not use this appliance if any part has been under water. Immediately call a qualified service technician to inspect the appliance and to replace any part of the control system and any gas control which has been under water.

OPERATING INSTRUCTIONS

1. **STOP!** Read the safety information above on this label before doing anything.
2. Set the thermostat to lowest setting.
3. Turn off all electric power to the appliance by selecting main power switch to OFF.
4. This appliance is equipped with an ignition device which automatically lights the burner. Do not try to light the burner by hand.
5. Locate manual gas shut-off valve (see pictures below) and turn clockwise to "CLOSE".
6. Wait five (5) minutes to clear out any gas. Then smell for gas, including near the floor. If you smell gas, **STOP!** Follow step "B" in the safety information above on this label. If you don't smell gas, go to the next step.
7. Turn gas control valve to OPEN.
8. Turn on electric power to appliance by turning main power switch to ON.
9. Set thermostat to desired setting.
10. If the appliance will not operate, follow the instructions "TO TURN OFF GAS APPLIANCE" and call your service technician or gas supplier.

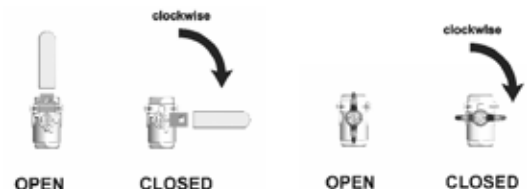
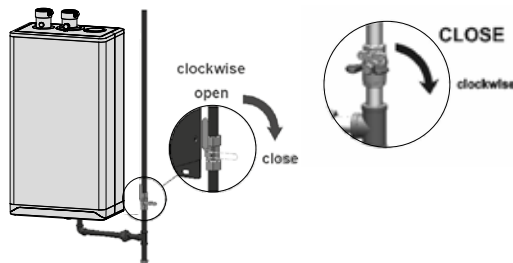

TO TURN OFF GAS APPLIANCE

1. Set the thermostat to lowest setting.
2. Turn off all electric power to the appliance by turning main power switch to OFF.
3. Turn gas control valve to CLOSE.

⚠ DANGER

- Fill trap with water before unit is first fired to prevent exhaust fumes from entering room. Never operate the unit unless the trap is filled with water.

Failure to comply will result in severe personal injury or death.

- It is forbidden to make adjustments to the gas valve except with a properly calibrated gas combustion analyzer by persons who are trained and experienced in its use. Failure to use an analyzer can result in an immediate hazard.

3.2 PRIOR TO START-UP

3.2.1 Pre-Ignition Checks

1. Fill the condensation trap. Ensure the venting system is complete and seal-tested. Confirm that any common venting system at the installation site is isolated and independent of the unit, that any holes left from removal of a previous unit have been sealed, and that any resizing of the old flue has been done.
2. Check that the water piping system is fully flushed and filled, and that all air has been discharged. Use a minimum water pressure of 12 psig and confirm that the pressure relief valve is installed and discharge line is directed downward to a safe point of discharge.
3. Check to see that adequate gas pressure is present at the inlet gas supply test port. With the unit gas valve shut off, using a Torx 15 screwdriver, open the test port by turning 1 full turn counterclockwise. Connect a manometer and open the manual gas valve. Requirements are minimum 4" w.c. and maximum 14" w.c. Check that there are no gas leaks.
4. Perform a final check of electrical wiring and provide power to the unit to initialize operation.
5. The installer must verify that at least one carbon monoxide alarm has been installed within a residential living space or home following the alarm manufacturer's instructions and applicable local codes before putting the appliance into operation.

3.2.2 Test Ignition Safety Shutoff

With the unit in operation, test the ignition system safety shutoff device by shutting off the manual gas valve immediately outside the unit case. Ensure that the unit has shut off and that the appropriate error information is displayed on the main display screen. To restart the unit, press the reset button.

3.3 COMMISSIONING

The Heating Boiler is factory calibrated to operate with natural gas at sea level. High Fire combustion is set by the orifice installed and is not field adjustable. A low calorific value natural gas orifice (See Table 9) is available for locations where the natural gas calorific value falls below the expected range of 950-1100 BTU/Ft³. Consult your local fuel provider for your fuel's calorific value. Low fire is field adjustable via the low fire adjustment on the gas valve but must be done with caution. No mixture adjustment may be performed unless done by a qualified technician using a properly functioning and calibrated combustion analyzer.

This unit can burn either natural gas or propane if equipped with the correct specified orifice. Examine the rating plate of the unit to ensure it is configured for the fuel you are using. If the unit is to be converted from natural gas to propane or from propane to natural gas a fuel conversion kit must be installed. For the correct fuel conversion kit part number, see the table on the next page:

⚠ WARNING

Check the rating plate of the unit to ensure it is configured for the fuel you are using. If the fuel is incorrect for the appliance, a conversion kit must be installed as listed in table 9, and the gas valve adjusted accordingly.

Failure to perform the required fuel conversion can result in an immediate hazard.

⚠ DANGER

Attempting to change high fire combustion by adjusting the low fire combustion adjustment could lead to unstable operation, failed ignitions, or dangerous operating conditions.

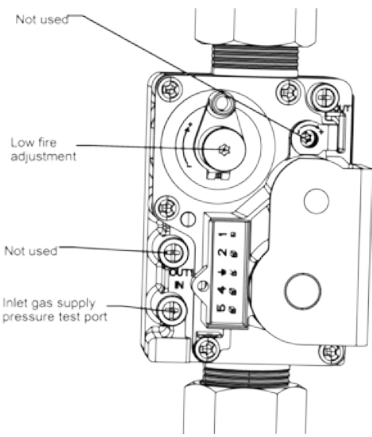

Figure 42 Gas Valve Adjust

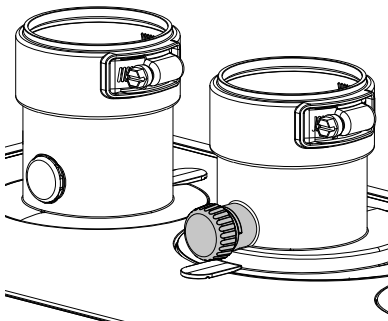

Figure 43 Flue gas test port plug

MODEL	NATURAL GAS TO PROPANE	PROPANE TO NATURAL GAS	LOW CALORIFIC NATURAL GAS
99,000 Btu/hr	P-081034	P-081044	P-081364
120,000 Btu/hr	P-081054	P-081064	P-081374

Table 9: Fuel conversion kits

The gas valve will automatically de-rate the maximum input by approximately 2% per 1,000' above sea level. The gas valve's zero governor will ensure that the gas-air mixture is not affected at altitude.

To verify the proper operation of the gas valve in the field, the following procedure can be carried out by a qualified technician (see diagrams on this page).

1. Turn off the unit's manual gas valve. With a Torx 15 screwdriver, open the inlet gas supply pressure test port by turning its screw 1 full turn counterclockwise. Attach a manometer to the pressure test port. Turn on gas to the appliance. Static manometer reading should be ideally 7" w.c., for natural gas and 11" w.c. for propane. Minimum and maximum static pressure must be between 4" and 14" w.c. Monitor pressure throughout the commissioning procedure. Pressure may droop up to 1" at high fire.
2. Allow the unit to ignite / run against a large load. To maintain high fire, press the flame icon, then press and hold the Wrench icon for two seconds. Then while holding the Wrench icon press the Plus button twice. "H" will show in the service display as the unit enters high fire.

NOTE: Allow the unit to operate at high fire for 3 minutes to stabilize. (The unit operates in manual mode for 10 minutes then switches back to the normal operating mode. To extend manual mode operation, press the and Plus together twice while the unit is operating in manual mode to reset the timer for 10 more minutes.) Do not take measurements if the Service display shows an "h".

3. Clock the natural gas meter to confirm full maximum rating plate input. With a combustion analyzer probe in the flue gas test port, check the measured results against Table 10 - High Fire. If the results are outside the permitted range, check the inlet pressure, and confirm that the correct orifice and venturi are installed. High Fire CO₂ is set by the orifice installed and is not field adjustable. For areas of lower calorific value natural gas, install the alternative orifice listed in Table 9.
4. Switch the unit to low fire by pressing the Wrench button and Minus - buttons at the same time. The unit will drop to low fire. "L" will show on the service display. Compare the readings with Table 10 - Low Fire. If adjustment is necessary, remove the low fire adjustment cap to reveal a Torx head screw. Make minimal adjustments, typically less than 1/8th of a turn at a time. Turn the screw clockwise to increase CO₂ and counter-clockwise to reduce CO₂. If the target cannot be met, even after a full turn, contact the factory. When finished, replace the low fire cap, and leave the manual mode by pressing + AND - simultaneously.
5. Switch off the unit by pressing the space above the dot for two seconds. Turn off the gas at the unit's manual gas valve. Remove the flue gas analyzer from the test port and reinstall the test port cap. Remove the gas pressure manometer from the gas valve and fully close the test port. Turn on the gas at the gas shut off valve. Ensure that there are no gas leaks and reinstall the front cover. Turn on the unit by pressing the space above the dot for two seconds.

⚠ DANGER

Operating any unit using a fuel other than the fuel listed on its rating plate is prohibited. If the information in this section related to conversion to alternative fuels is not followed exactly, a dangerous situation can result, leading to fire or explosion, which may cause property damage, personal injury, or loss of life.

PROPANE ORIFICE CHART

MODEL	ORIFICE SIZE
99,000 Btu/hr	327
120,000 Btu/hr	392

NATURAL GAS ORIFICE CHART

MODEL	ORIFICE SIZE
99,000 Btu/hr	415
120,000 Btu/hr	480

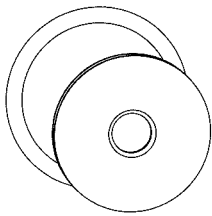

Figure 44: Orifice and O-ring

⚠ WARNING

Ensure the part kit and orifice are correct for the appliance model and fuel type prior to performing the fuel conversion.

3.4 FUEL CONVERSION

The unit is factory fire-tested to operate with natural gas as shown on the rating plate. Firing a unit with a fuel other than what is listed on the rating plate is prohibited unless the following conversion procedure is completed by a qualified technician.

Fuel conversion requires hardware adjustments (orifice replacement) as well as measurement and possible tuning of the low fire mixture. Detailed instructions including parts and labeling are found in Fuel Conversion kits. Refer to Table 9 for the correct kit number.

	NATURAL GAS	PROPANE
CO₂ VALUE (%) AT HIGH FIRE WITH THE FRONT COVER OPEN¹		
Max. CO ₂ value	10.3%	11.0%
Min. CO ₂ value	8.7%	9.8%
CO LIMIT (PPM) AT HIGH FIRE WITH THE FRONT COVER OPEN²		
Max. CO limit	< 150ppm	<250ppm
CO₂ VALUE (%) AT LOW FIRE WITH THE FRONT COVER OPEN		
Max. CO ₂ value	= value at High	= value at High – 0.3%
Min. CO ₂ value	8.7%	9.5%

Table 10: Acceptable High and Low Fire Combustion Values

¹ High Fire CO₂ is set by the orifice installed and is not field adjustable.

² If the CO reading exceeds the limit in this table, the unit must be shut down until the cause of excessive CO readings is corrected. - The following procedure must be carried out by a qualified technician.

1. Ensure that the gas supply is turned off at the manual gas valve.
2. Disconnect the electrical power.
3. Disconnect the nut at the gas valve outlet (top of the gas valve) and remove the orifice and O-ring.
4. Insert the correct orifice into the O-ring, and re-install into the nut at the gas valve outlet (top of the gas valve) and then tighten the nut.
5. Restore the gas supply by opening the manual gas valve.
6. Test for leaks by using an approved leak detection solution on all joints.
7. Carefully follow the "Prior to Start-Up" – Section 3.2 and "Commissioning" – Section 3.3 procedures on the preceding page 3-2.

⚠ WARNING

Each unit is equipped with a back flow valve installed at the outlet of the fan. Inspect the back flow flapper annually.

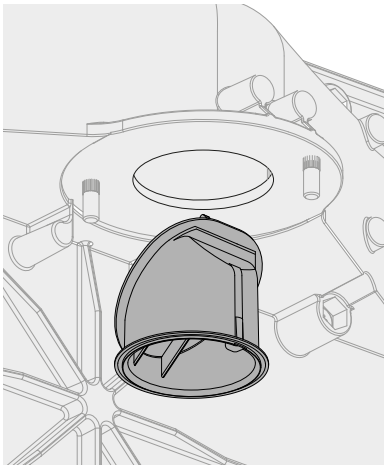

Figure 45: Back Flow Valve

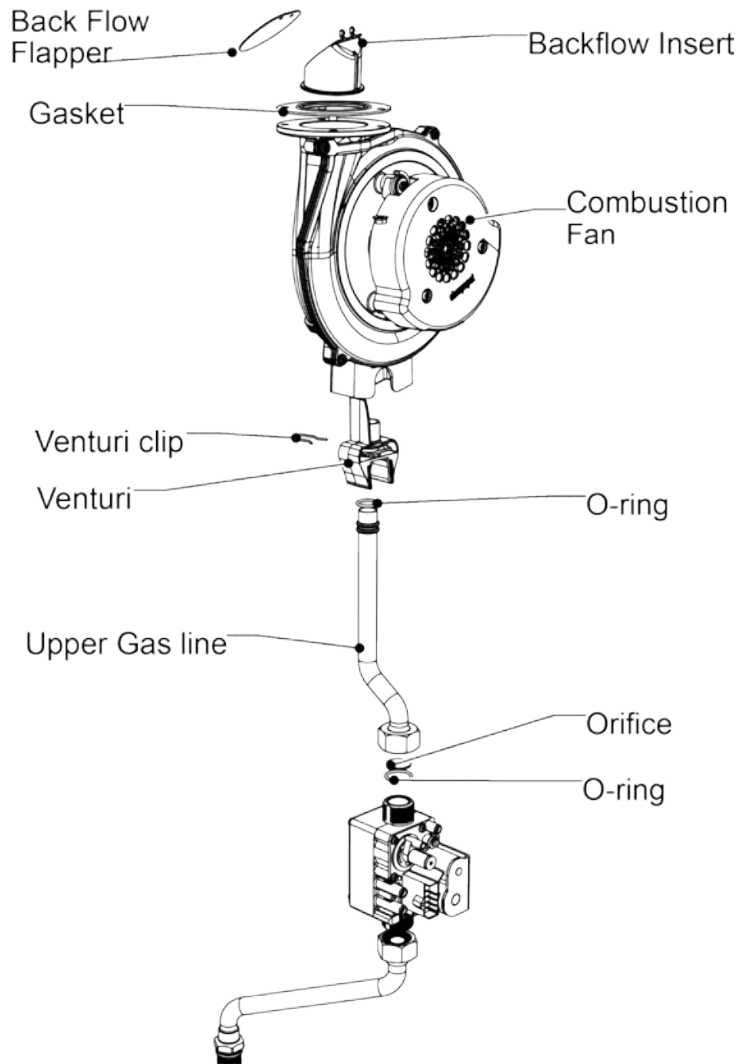

Figure 46: Blower and Gas Valve Assembly

⚠ NOTE

The Caution regarding burner refractory on page 4-2 of this manual must be observed.

⚠ CAUTION

When removing the heat exchanger cover in step 6, be careful not to damage the burner and refractory material located on the opposite side of the heat exchanger cover. Use caution when handling refractory materials. See Caution on page 4-2.

3.4.1 Gaining access to combustion chamber, burner removal instructions

DISASSEMBLY

1. Turn off the main power switch to the unit.
2. Turn off the gas supply valve to the unit.
There is no need to drain the unit unless the unit will be exposed to freezing conditions while off.
3. Remove the front cover, and allow the unit to cool.
4. Unplug the electrical connector at the gas valve and fan.
5. Loosen the lower gas valve connection nut.
NOTE: There is an O-ring in the lower gas connection. Cover the gas piping connections to prevent debris from entering the gas piping.
6. Remove all 6mm Allen bolts from the heat exchanger cover and carefully remove the front cover complete with the fan and the gas valve attached.
7. Place the heat exchanger cover in a safe location.

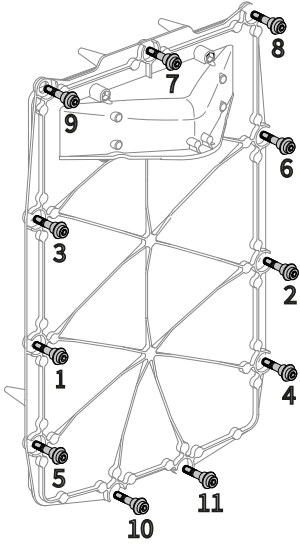

Figure 47: Tighten Allen bolts in cross pattern direction.

REASSEMBLY

- 1.** Replace the heat exchanger gasket. Inspect, and when needed change other gaskets. If necessary, inspect and clean the gasket mating surface.
- 2.** Place the heat exchanger cover onto the heat exchanger and loosely install the 6mm Allen bolts removed in step 6. Tighten the 6mm Allen bolts in a cross pattern as shown in the Figure 47.
- 3.** Connect the gas line to the gas valve ensuring the O-ring is in place. Tighten the gas valve nut. Ensure the upper gas valve connection is tight. Re-connect the gas valve electrical connection.
- 4.** Re-connect the electrical connection to the fan.
- 5.** Inspect the condensate trap for debris. Remove and clean if necessary. Fill the condensate trap with water.
- 6.** Turn on the gas supply valve to the unit and inspect for gas leaks. Use an approved leak detection solution. Soap test all joints.
- 7.** Ensure the unit is full of water and purged of air if the unit was drained during disassembly.
- 8.** Turn on the power to the unit and create a call for heat or for domestic hot water.
- 9.** Inspect the gasket around the unit cover.
- 10.** Check flue gases for proper combustion. See *Section 3.3 Commissioning* for proper adjustments.
- 11.** Re-install the unit's cover and set the unit into normal operation.

⚠ WARNING

- Fill the trap with water before the unit is first fired to prevent exhaust fumes from entering the room. Never operate the unit unless the trap is filled with water.

Failure to comply will result in severe personal injury or death.

- Whenever the burner is removed for inspection or unit servicing, examine the sealing gaskets and replace if damaged.

⚠ CAUTION

- The owner is responsible for general care of the unit. Improper maintenance of the unit may result in a hazardous condition.

- Periodic inspection of the low water cut-off device, including flushing of float types, is required, if installed as an accessory to the unit.

- When servicing controls, label all wires prior to disconnection. Wiring errors can cause improper and dangerous operation.

- When removing a burner, a new burner gasket is required.

4.0 MAINTENANCE

4.1 UNIT MAINTENANCE

4.1.1 General Care

- Keep combustible materials and flammable liquids and vapors away from the unit.
- Keep vent terminals clear of obstructions (snow, dirt, etc.).

4.1.2 Inspection

Inspection of the unit must be performed annually by a qualified service technician.

4.1.3 Venting

- Check vent terminals for any obstructions (e.g. leaves, dust, other debris).
- Check and clean or replace intake or screens as required.
- Check for holes or leaks in venting. Replace venting as needed.
- Examine for any signs of moisture caused by sweating intake air pipes. Insulate as required.
- Ensure proper resealing or reinstallation of venting at each servicing.

4.1.4 Condensate Trap

- Examine the condensate trap every two months to see if cleaning is necessary (*refer to trap cleaning instructions, section 4.1.16 of this manual*). Ensure that the trap has been re-filled completely before firing the unit.
- Check the pH level of the condensate discharge if using condensate neutralization.

4.1.5 Burner

- At the first annual service, remove the burner to inspect the extent of fouling (*refer to burner removal and reassembly instructions, section 3.4.1 of this manual*). Blow clear using compressed air. Evaluate the magnitude of cleaning required, and establish a reasonable burner inspection schedule. Some installations may call for annual service, others showing clean burners will only need attention every 2 years. In alternate years, visually inspect burner through the sight glass. Ensure the flame is stable and without excessive fluttering. Normal flame pattern is evenly distributed over the burner surface.
- If the burner is operating improperly, remove and clean or replace. Use a combustion analyzer to determine proper combustion. See *Table 10 for correct values*.

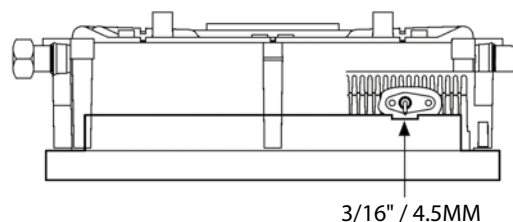

Figure 48: Checking igniter gap using 251-001 Ignitor Gapping Tool

⚠ CAUTION

The heat exchanger has a small amount of combustion chamber insulation (refractory), that contains ceramic fibers.

When exposed to extremely high temperatures, the ceramic fibers, which contain crystalline silica, can be converted into cristobalite, classified as a possible human carcinogen.

Avoid disturbing or damaging the refractory. If damage occurs, contact the factory for directions.

Avoid breathing in fumes and contact with skin and eyes. Follow these precautions:

1. For conditions of frequent use or heavy exposure, you need a respirator. For respirators certified by NIOSH, refer to the "NIOSH Guide to the Selection and Use of Particulate Respirators Certified under 42 CFR 84".
For current information, contact NIOSH on 1-800-356-4676 or on the web at www.cdc.gov/niosh.
2. Wear long sleeved, loose fitting clothing, gloves and eyes protection.
3. Assure adequate ventilation.
4. Wash with soap and water after contact.
5. Wash potentially contaminated clothes separately from other laundry, and rinse clothes thoroughly.
6. Discard used insulation in an air tight plastic bag.

NIOSH first aid guidelines:

- Eye contact - Irrigate and wash immediately.
- Breathing in fumes - Provide fresh air.

4.1.6 Heat Exchanger

During annual inspection (with the heat exchanger cover removed), examine the heat exchanger for signs of contamination and clean if necessary. In areas of poor gas quality or contaminated combustion air, there may be a build-up of black plaque (typically sulfur). Other fouling agents are airborne dust, debris and volatiles. Clean the heat exchanger surface with a stiff plastic bristle brush only.

During maintenance, the heat exchanger gasket must be replaced. Inspect other gaskets, and change when needed. *Refer to the heat exchanger cover removal instructions in Section 3.4.1* for access to the combustion chamber and heat exchanger. **Observe the safety warning regarding the burner refractory on this page.**

4.1.7 Pump

Check that the pump is on in normal space heating operation, and that the water ΔT is reasonable for the heating application.

4.1.8 Gas Piping

Check for damage or leaks, and repair as needed.

4.1.9 Control Module

- Check that unit operation is consistent with the steps in *Section 2.6 Sequence of Operation*.
- Check that water temperature targets and setpoint are satisfactory, and have not been adversely adjusted.

4.1.10 Water Heating System

- Check water pressure and temperature. There should be no noticeable change if the unit and system components are functioning normally. Check for any noise in the system.
- Check heating system water piping for damage or leaks, and repair as needed.
- Check for 12-15 psig in normal operation, and look to ensure pressure does not run up toward 30 psig at high temperature. If pressure rises sharply, consider replacement of the expansion tank. Check also for noise at high fire that may signal water quality problems.
- Water chemistry must be of a quality generally accepted as suitable for hydronic applications. *See Section 1.6 for details.*
- Ensure that any direct "city fill" water connections are left in the **closed** position to minimize exposure to leaks and flooding.

4.1.11 Freeze Protection

The unit's controller operates the unit as needed to protect it from freezing. If the unit and system components are vulnerable to freezing we recommend using a freeze protection solution. Use antifreeze made specifically for hydronic systems. We recommend inhibited propylene glycol.

Antifreeze concentration must be between 25% and 50% of the total volume of water in the system.

⚠ WARNING

Do not use automotive-type ethylene or other types of automotive glycol antifreeze, or undiluted antifreeze of any kind. This may result in severe unit damage. The installer is responsible in ensuring that glycol solutions are formulated to inhibit corrosion in hydronic heating systems of mixed materials. Improper mixtures and chemical additives may cause damage to ferrous and non-ferrous components as well as non-metallic, wetted components, normally found in hydronic systems. Ethylene glycol is toxic, and may be prohibited for use by codes applicable to your installation location. For environmental and toxicity reasons, we require only using non-toxic propylene glycol.

⚠ NOTE

Installers should contact the local water supplier about the suitability of their water for use in hydronic heating systems.

If water quality is questionable, a local water treatment expert must be consulted for testing, assessment and, if required, treatment.

Alternatively, water or hydronic fluid of known quality can be brought to the site.

⚠ CAUTION

Before testing the relief valve, make certain the discharge pipe is properly connected to the valve outlet, and arranged to contain and safely dispose of equipment discharge.

4.1.12 System Treatment

- Check consistency of any system treatment used, for appropriate mixture. Chemical inhibitors are consumed over time, lowering their density.
- Verify proper operation after servicing.

4.1.13 Relief Valve - Maintenance and Testing

The relief valve manufacturer requires that under normal operating conditions a “try lever test” must be performed quarterly. Under severe service conditions, or if corrosion and/or deposits are noticed within the valve body, you must test more often. Also perform a “try lever test” at the end of any non-service period.

Test at or near maximum operating pressure by holding the test lever fully open for at least 5 seconds to flush the valve seat free of sediment and debris. Then release the lever and permit the valve to snap shut.

If the lever does not activate, or there is no evidence of discharge, discontinue use of equipment immediately, and contact a licensed contractor or qualified service personnel.

If the relief valve does not completely seal, and fluid continues to leak from the discharge pipe, perform the test again to try and flush any debris that may be lodged in the valve. If repeated attempts fail to stop the leakage, contact a licensed contractor or qualified service personnel to replace the valve.

While performing a “try lever test”, a quantity of heat transfer fluid will be discharged from the piping system, and the system pressure will drop. This fluid must be replaced. We highly recommend using a system pressurization unit such as an *Axiom Industries model MF200* to refill and pressurize your system. Capture the discharged fluid in a container and recycle it by returning it to the system feeder unit. This is particularly important when your system contains treatment chemicals or glycol solutions. If the system employs plain water, turn on the unit’s auto fill valve to recharge the lost fluid.

4.1.14 Fan removal instructions

1. Turn off the power and the gas supply to the unit.
2. Remove the front cover, and allow the unit to cool down.
3. Disconnect the electrical plug attached to the fan.
4. Loosen the union nut at the top of the gas valve. Carefully remove the orifice and O-ring, and keep in a safe place for re-installation later. Ensure you protect the gas valve outlet from dust and debris.
5. Remove the 2 hex nuts connecting the fan to the burner housing, and carefully remove the fan. You will find a gasket attached to the fan outlet as well as an internal check valve. Keep these items in a safe place for re-installation.
6. If the removed fan is to be re-installed, ensure the fan and venturi are clean and dust free. If the fan is being replaced, move the venturi over to the new fan. Note that the fit is tight.

⚠ DANGER

When servicing or replacing the fan, you must transfer the venturi from the old fan to the new fan.

Failure to relocate the venturi to the new fan may cause an immediately hazardous situation which must be avoided in order to prevent serious injury or death.

4.1.15 Fan installation instructions

1. Place the fan gasket on the outlet of the fan housing. The gasket has 2 locator pins to ensure the gasket does not move during installation.
2. Reinstall the check valve in the burner housing and attach the fan to the burner housing with the 2 hex nuts. Tighten the 2 hex nuts with a wrench.
3. Insert the orifice and O-ring between the gas valve outlet and the gas line to the fan. Tighten the gas valve union nut with a wrench. Ensure that the gas valve inlet (lower) nut is tight.
4. Connect the electrical plug to the fan.
5. Restore the gas supply to the unit, and test the gas valve inlet for gas leaks.
6. Restore the power to the unit, and create a call for heat or hot water.
7. Check for leaks at the gas valve outlet and the connection between the fan and the burner housing.
8. Install the cover to the unit.
9. Return the unit to normal operation.

4.1.16 Cleaning the Condensate Trap

1. Turn off the power and the gas supply to the unit.
2. Remove the front cover, and allow the unit to cool down.
3. Remove the flexible hose (1) from the condensate trap and drain.
4. Detach the condensate trap cup (2) by rotating it to the left (counter-clockwise) and then pulling it downwards.
5. Empty the condensate trap cup (3).
6. Detach the condensate trap base (4) by pressing the three securing clips in, while simultaneously pushing the condensate trap base downwards (4).
7. Remove the circlip and the plastic ball from the condensate trap base (5).

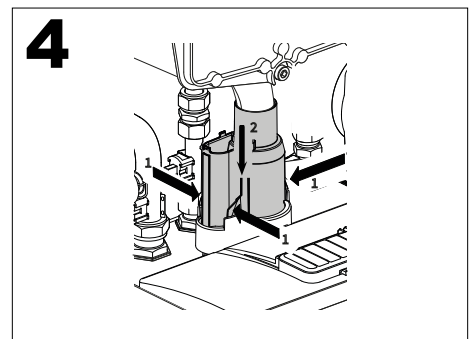
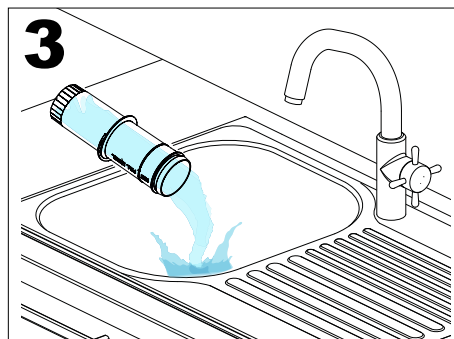
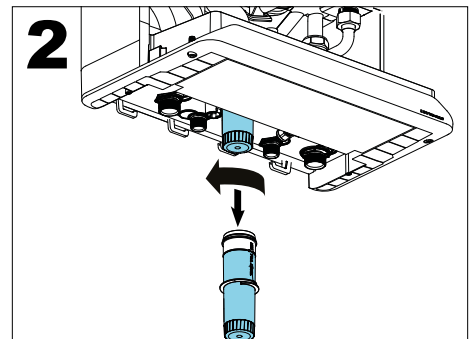
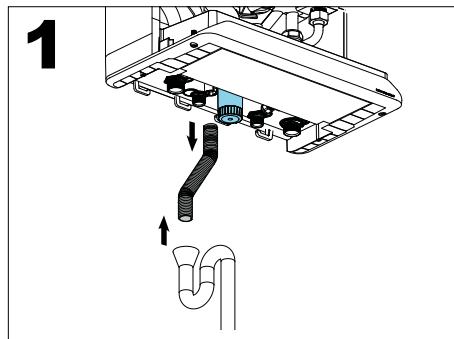

8. Clean the following components with water:

- the inside of condensate trap base
- plastic ball
- circlip
- condensate trap cup
- opening of the flue pipe

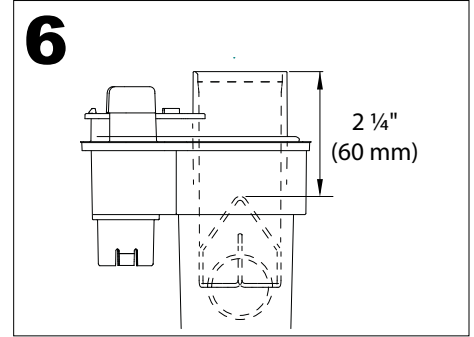
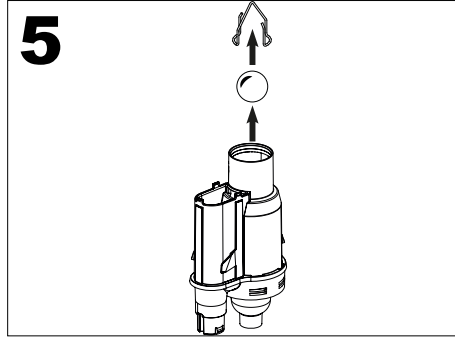

⚠ DANGER

Make sure that the condensate trap base is returned to its original position, firmly locked into the bottom with no gaps.

Incorrectly attaching the condensate trap base (or not attaching it at all) will result in products of combustion leaking into the room creating a dangerous situation.

9. Return the plastic ball to the condensate trap base and attach the circlip.

10. Check that the ball and circlip have been installed correctly (6). Make sure that the top of the circlip is about 2 1/4" (60 mm) below the edge of the condensate trap base.

11. Replace the O-ring (part #150-367) at the bottom of the flue pipe.

12. Attach the condensate trap base to the bottom by pushing it high enough so that the securing clips click over the lip (8).

13. Make sure the condensate trap cup is 3/4 filled with water (7) before installation, slide it into the condensate trap base and rotate it to the right (clockwise) until it is correctly secured (9).

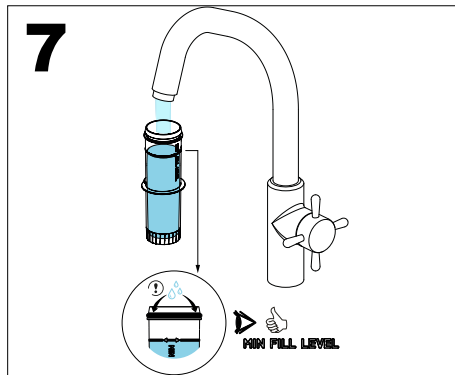
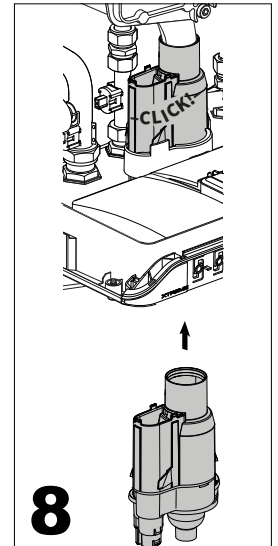

14. Slide the flexible hose onto the condensate trap base and into the drain (10)

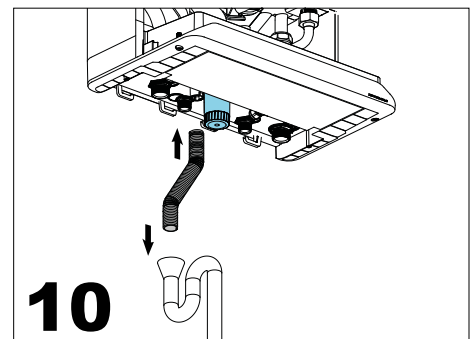
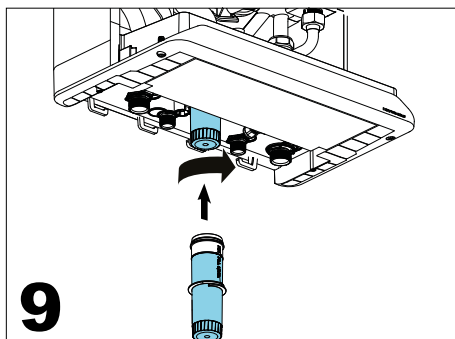

⚠ CAUTION

The maintenance counter must only be reset after performing the maintenance procedures in Section 4.0 Maintenance of this manual. Failure to perform maintenance can result in a hazardous condition.

⚠ NOTE

Damage to the Heating Boiler caused by freezing water is not covered by the warranty.

4.1.17 Reset the Maintenance Counter

The maintenance counter should be reset after all maintenance items in this section have been completed. Refer to Resetting the Maintenance Counter, section 2.8 of this manual.

4.1.18 Winterization

The Heating Boiler must be winterized along with the rest of the heating system when the system will be shut down for an extended period of time and be subject to freezing conditions.

1. Turn off the power and the gas supply to the unit.
2. If the heating system does not contain the proper level of propylene glycol to prevent freezing, drain the units space heating coil along with the rest of the heating system.
3. Remove the condensate trap cup and empty.
4. If present, empty condensate pump.

NOTE

This unit is equipped with a blocked vent shut-off system that closes the gas supply when it detects an irregular venting condition.

5.0 TROUBLESHOOTING

The troubleshooting section is divided into four sections:

- 5.1 Preliminary Checks**
- 5.2 Electronic Components**
- 5.3 Faults and Notifications**
- 5.4 Other Faults**

Often, you can identify and solve a problem through simple checks of the basics: confirming the electrical power supply, gas flow and resetting the thermostat control. To help with preliminary checks, the unit's control module offers a clear visual display of the status of the various control circuit components.

Should a problem remain unsolved after applying the preliminary checks, proceed to the detailed system review in this guide. The Troubleshooting chapter covers potential error conditions, grouped into the following categories:

- 5.3.1 Faults Codes**
- 5.3.2 Notification Codes**
- 5.4.1 No heat (space heating)**
- 5.4.2 Space heating does not reach the correct temperature**
- 5.4.3 Space heating system remains too warm**
- 5.4.4 Burner ignites loudly**
- 5.4.5 Burner resonates**

Below each section is a list of symptoms, diagnoses, and solutions.

Some diagrams (see *Section 6.0*) are included for use with troubleshooting including:

- Electrical Wiring Diagrams
- Unit Component Layout Diagrams

5.1 PRELIMINARY CHECKS

As a first step in troubleshooting, you should review the controller's display screen. Diagnostic features evaluate system integrity, display error conditions, and indicate initial troubleshooting action.

In addition to checking the controller's display, try these troubleshooting steps:

- 1.** Confirm power to the unit: check that control module display is on (e.g., display is lit).
- 2.** Check that unit is not in a safety lockout.
- 3.** Ensure that wiring is secure and properly terminated.
- 4.** Check that gas is reaching the unit.
- 5.** Confirm that the water system is properly pressurized to 12 psig and that the pump is operating.

5.2 ELECTRONIC COMPONENTS

This section details the method for troubleshooting the non-standard electronic components on the unit, including the electronic water pressure sensor-type LWCO and the temperature sensors.

5.2.1 Temperature Sensors

The resistance of the temperature sensors varies inversely with temperature. To test, measure the temperature of the sensed environment and compare with the value derived from the measurement of the resistance (obtained by connecting a good quality test meter capable of measuring up to 5,000 KΩ (5,000,000Ω) at the controller end of the sensor lead).

To obtain a resistance reading, remove power to the unit. For the supply water and return water temperature sensors, remove the wire leads by disconnecting their respective Molex connectors. Place multi-meter probes into the sensor's male Molex connector socket. Do not apply voltage to the sensor as damage may result.

12KΩ temperature sensors are supplied with the unit. See Table 12 for resistance values.

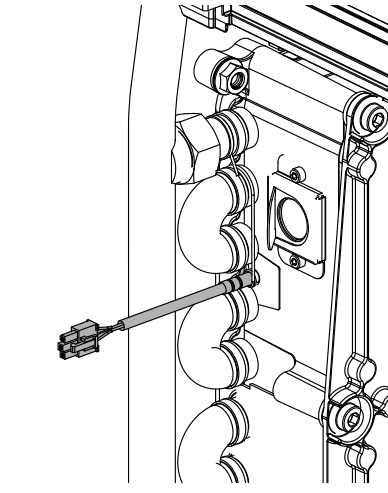

Figure 49: Heat exchanger temperature sensor S0

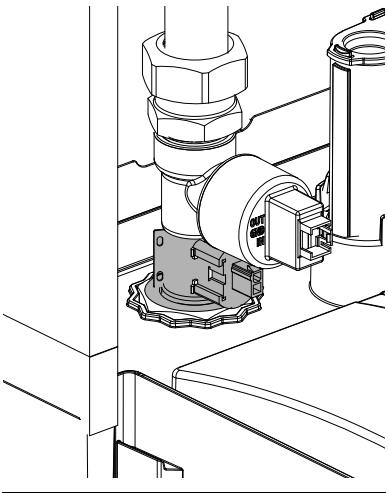

Figure 50: Heating Supply temperature sensor S1

SENSOR	TYPE	PURPOSE	LOCATION
S0	NTC 12KΩ	Heat Exchanger Temperature	Left Side of Heat Exchanger
S1	NTC 12KΩ	Heating Supply Temperature	Heating Supply Pipe
S5	NTC 12KΩ	Flue Gas Temperature	Top of rear Flue passage
S6	NTC 12KΩ	Outdoor Sensor	Outdoors (North side)
S7	NTC 10KΩ	Hot Water Tank	External Water Heater
PTC1 PTC2	PTC	Cabinet Temperature	Left and right Side top of inner cabinet
		Water Pressure	Heating Supply Pipe

Table 11: Temperature and Pressure Sensors

5.2.2 Fan/Blower

Control and power to the fan is provided via a single wiring harness to the controller.

TEMPERATURE	RESISTANCE	TEMPERATURE	RESISTANCE	TEMPERATURE	RESISTANCE
F / C	Ω - ohm	F / C	Ω - ohm	F / C	Ω - ohm
5F / -15C	76,020	77F / 25C	12,000	149F / 65C	2,752
14F / -10C	58,880	86F / 30C	9,805	158F / 70C	2,337
23F / -5C	45,950	95F / 35C	8,055	167F / 75C	1,994
32F / 0C	36,130	104F / 40C	6,653	176F / 80C	1,707
41F / 5C	28,600	113F / 45C	5,522	185F / 85C	1,467
50F / 10C	22,800	122F / 50C	4,609	194F / 90C	1,266
59F / 15C	18,300	131F / 55C	3,863	203F / 95C	1,096
68F / 20C	14,770	140F / 60C	3,253	212F / 100C	952

Table 12: Temperature Sensor Resistance Values – 12KΩ sensors.

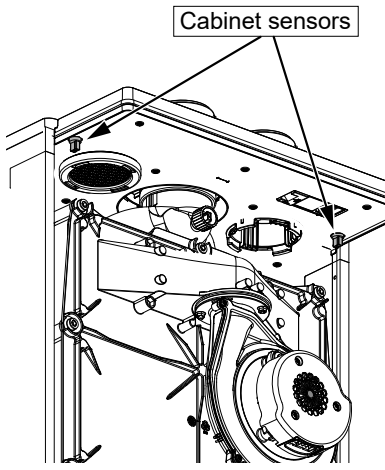

Figure 51: PTC Cabinet Temperature Sensors

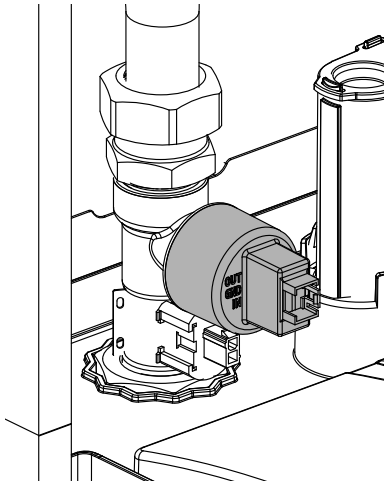

Figure 52: Water Pressure Sensor Type LWCO

5.2.3 Cabinet Sensors

The Cabinet temperature sensors ensure that the unit shuts down if the temperature inside the cabinet is above normal.

The Cabinet temperature sensors are located on the left and right side at the top of the cabinet. To remove the sensors, unclip the wiring harness and unscrew from the top cabinet.

5.2.4 Thermostat Connections

The unit's controller is designed to heat a single space heating load. The load can consist of a single zone or several zones. In either method, the 'Call for Heat' must be from a device providing a dry contact and connected to X13.1 and X13.2. The use of power-robbing thermostats directly will cause the unit to operate erratically. If using a power-robbing thermostat, you will need to isolate it through a relay. An Open Therm device can also be used across X13.1 and X13.2.

5.2.5 Water Pressure Sensor-Type Low Water Cut Off (LWCO)

The unit is equipped with a pressure sensor that serves as a low-water cut-off. The water pressure is displayed in the main display when the pressure is low. For example, a system water pressure of 4.6psi would be displayed as 4.6P. If the pressure is too low the controller flashes an error message in the main display by toggling between the actual pressure and LO. To correct this error, increase the system pressure. The water pressure in the heating system must be higher than 8psi for the unit to reach maximum firing rate. When the water pressure is less than 8psi, the unit restricts its firing rate. If the pressure is less than 4psi then the unit will not fire at all.

To test the operation of the pressure sensor – type LWCO

1. Turn off the unit at the controller by pressing the area above the dot. The current system pressure is displayed.
2. Isolate the space heating circuit, and reduce the water pressure. The displayed water pressure should drop as the system water is being removed (expansion tank isolated). If the pressure remains steady the pressure sensor may be blocked or faulty. If it remains "fixed", drain the unit and replace the sensor, or dislodge any blocking debris from the sensor inlet channel and reinsert.
3. If the pressure sensor is OK refill the unit and open the closed valves. Ensure the system pressure is adequate for the heating system.

Pressure sensor lwco replacement

1. Turn off the power to the unit.
2. Isolate and drain the unit.
3. Disconnect the electrical connection to the sensor.
4. Carefully remove the pressure sensor by loosening it, turn the nut counter clockwise until it can be removed. If there is some water leakage, ensure the water does not spill into the controller.
5. Push the new sensor into the socket while twisting slightly. Take care to avoid damage to the O-ring.
6. Connect the electrical connector to the sensor.
7. Restore water pressure to the unit.
8. Restore power to the unit.

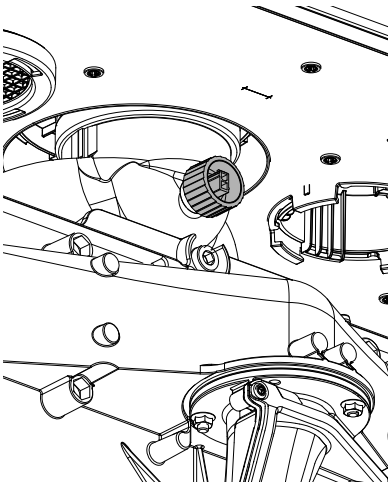

Figure 53: Flue gas Temperature Sensor S5

5.2.6 Flue Gas Temperature Sensor

This sensor ensures that the unit shuts down safely if the flue temperature is above normal. High flue temperatures can be an indication that the heat exchanger requires cleaning.

The flue gas temperature sensor is located at the top of the rear flue passage, below the top panel. To remove the sensor, unclip from the wiring harness and unscrew from the rear flue passage.

5.2.7 Outdoor Sensor

An outdoor sensor is supplied with each unit. The sensor should be mounted on the north side of the building away from any direct sunlight. Keep the sensor away from any heat sources such as exhaust fan outlets, dryer outlets, mechanical room ventilation grills etc.

The Outdoor sensor is a 12K Ω sensor with resistance values as listed in Table 12. If the sensor is not connected to the unit, the unit operates at the unit's supply temperature set in the User Setup menu, and operates as a set point load.

5.2.8 DHW Tank Sensor

The Heating Boiler allows the use of a tank sensor for controlling the domestic hot water tank temperature. A 10K Ω sensor or an aquastat can be used to operate the Heating Boiler.

If a field supplied domestic hot water sensor is used, it must be a 10K Ω sensor matching the following table.



Figure 54: Outdoor air Temperature Sensor

TEMPERATURE		RESISTANCE	TEMPERATURE		RESISTANCE
°F	°C	Ω	°F	°C	Ω
0	-18	85,362	100	38	5,828
5	-15	72,918	105	41	5,210
10	-12	62,465	110	43	4,665
15	-9	53,658	115	46	4,184
20	-7	42,218	120	49	3,760
25	-4	39,913	125	52	3,383
30	-1	34,558	130	54	3,050
35	2	29,996	135	57	2,754
40	4	26,099	140	60	2,490
45	7	22,763	145	63	2,255
50	10	19,900	150	66	2,045
55	13	17,436	155	68	1,857
60	16	15,311	160	71	1,689
65	18	13,474	165	74	1,538
70	21	11,883	170	77	1,403
75	24	10,501	175	79	1,281
80	27	9,299	180	82	1,172
85	29	8,250	185	85	1,073
90	32	7,334	190	88	983
95	35	6,532	195	91	903

Table 13: Temperature Sensor resistance values – 10K Ω sensor

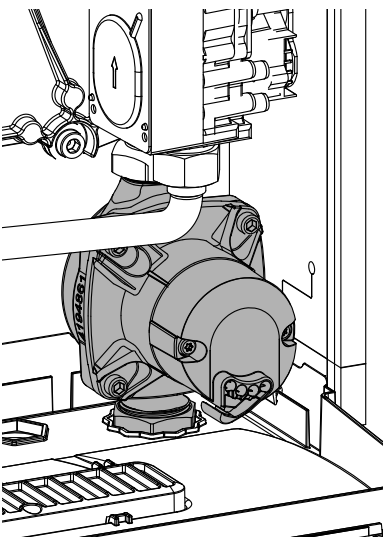

Figure 55: Pump

5.3 FAULTS AND NOTIFICATIONS

5.3.1 Fault Codes

During operation the controller can detect unusual situations and can take action to avoid damage to the heat exchanger or other unsafe operations. During these situations, the controller limits the temperature and power output of the burner, or temporarily disables operation entirely.

These faults are shown flashing and visible on the main display, and displayed only when an unusual reading is currently detected. Fault Codes can be reset by touching the wrench for 2 seconds after the cause of the fault has been resolved.

FAULT CODE	DESCRIPTION	POSSIBLE CAUSE / SOLUTION
F000	Heat exchanger temperature sensor fault.	<ul style="list-style-type: none"> • Verify wire harness connections at heat exchanger temperature sensor and control module are tight. • Replace heat exchanger temperature sensor.
F001	High heat exchanger temperature during central heating demand.	<ul style="list-style-type: none"> • Verify all air has been bled/purged from the heat exchanger central heating coil • Replace internal pump if it is not operating during a central heating demand. • Verify the unit has been converted to propane if operating on propane. • Verify combustion readings at low and high fire are within specifications. • Clean heat exchanger central heating coil. • Clean fire side of heat exchanger.
F002	High heat exchanger temperature during DHW demand	<ul style="list-style-type: none"> • Verify the unit has been converted to propane if operating on propane • Verify combustion readings at low and high fire are within specifications. • Clean heat exchanger DHW coil. • Clean fire side of heat exchanger.
F003	High flue temperature.	<ul style="list-style-type: none"> • Verify the unit has been converted to propane if operating on propane. • Verify combustion readings at low and high fire are within specifications. • Clean fire side of heat exchanger. • Clean heat exchanger central heating and DHW coils.

F004	No flame detected during four ignition trials.	<ul style="list-style-type: none"> • Verify external gas shutoff valve is open. • Verify gas inlet pressure is at least 4" during ignition trial. • Verify condensate drain is not blocked. • Check vent and combustion air piping for blockage. • Verify internal and power supply grounding. • Verify ground spring is in contact with burner head screw. • Verify ignitor to ignition module connection is tight. • Check ignitor condition and clean/replace as necessary. • Verify operation of the backflow flapper in the fan outlet. • Verify ignitor is not in contact with burner and gap is correct. • Replace ignition module if unit lights but flame icon doesn't illuminate. • Replace ignition module if spark is not present and 110VAC is present on ignition module black and gray wires. • Replace control module if spark is not present and 110VAC is not present on ignition module black and gray wires. • Replace gas valve if gas inlet pressure does not drop during trial for ignition and 24VDC is present at gas valve harness. • Replace control module if gas inlet pressure does not drop during trial for ignition and 24 VDC is not present at gas valve harness.
F005	No flame detected during operation.	<ul style="list-style-type: none"> • Verify condensate drain is not blocked. • Check vent and combustion air piping for blockage. • Check for flue gas recirculation. • If vent termination is subject to high winds, reconfigure/relocate as necessary. • Verify gas inlet pressure is at least 4" at both low and high fire. • Verify low and high fire combustion readings are within specifications. • Check ignitor condition and clean/replace as necessary.
F006	Flame detected when burner is off.	<ul style="list-style-type: none"> • Verify good internal and power supply grounding. • Verify flame goes out at conclusion of demand, if not replace gas valve. • Replace ignition module. • Replace control module.
F007	Low flame signal.	<ul style="list-style-type: none"> • Verify ignitor to ignition module connection is tight. • Check ignitor condition and clean/replace as necessary. • Verify low and high fire combustion readings are within specifications.
F008	Incorrect fan speed	<ul style="list-style-type: none"> • Verify wire harness connections at fan and control module are tight. • Replace fan. • Replace control module.

F009	Control module internal fault.	<ul style="list-style-type: none"> • Remove all field wiring from unit then reset fault. • Check field wiring for voltage backfeed if F009 fault does not return. • Replace control module if F009 fault code returns.
F010	Heat exchanger temperature sensor open.	<ul style="list-style-type: none"> • Verify wire harness connections at heat exchanger temperature sensor and control module are tight. • Check resistance of each heat exchanger temperature sensor (center pin is common), replace sensor if open circuit is found. • Check resistance of each heat exchanger temperature sensor (center pin is common) at control module harness connector, repair wire harness if open circuit is found.
F011	Heat exchanger temperature sensor short.	<ul style="list-style-type: none"> • Check resistance of each heat exchanger temperature sensor (center pin is common), replace sensor if short circuit is found. • Check resistance of each heat exchanger temperature sensor (center pin is common) at control module harness connector, repair wire harness if short circuit is found.
F012	Flue temperature sensor open.	<ul style="list-style-type: none"> • Verify wire harness connections at flue temperature sensor and control module are tight. • Check resistance of flue temperature sensor, replace sensor if open circuit is found. • Check resistance of flue temperature sensor at control module harness connector, repair wire harness if open circuit is found.
F013	DHW inlet temperature sensor open/short	<ul style="list-style-type: none"> • Verify wire harness connections at DHW inlet temperature sensor and control module are tight. • Check resistance of DHW inlet temperature sensor, replace sensor if open/short circuit is found • Check resistance of DHW inlet temperature sensor at control module harness connector, repair wire harness if open/short circuit is found
F014	Heat exchanger temperature sensor mounting fault.	<ul style="list-style-type: none"> • Heat exchanger temperature is not changing while unit is fired. • Verify heat exchanger temperature sensor is properly mounted on the heat exchanger.
F015	High cabinet temperature	<ul style="list-style-type: none"> • Check heat exchanger for flue gas leakage • Check vent pipe for flue gas leakage
F016	DHW outlet temperature sensor mounting fault	<ul style="list-style-type: none"> • DHW outlet temperature is not changing while unit is fired • Verify DHW outlet temperature sensor is properly mounted on the DHW outlet pipe

F017	DHW bypass valve fault	<ul style="list-style-type: none"> • Verify wire harness connections at DHW bypass valve and control module are tight. • Check resistance of DHW bypass valve at control module harness connector: Green - Purple = 30 to 40 Ω Green - Blue = 30 to 40 Ω Green - Yellow = 30 to 40 Ω Green - Orange = 30 to 40 Ω Red - Black = 5.5 to 6.5 MΩ Red - Brown = 17 to 21 MΩ If any resistance value is outside of these ranges, check and repair any wire harness open/short circuit before replacing DHW bypass valve.
F018	Flue/Combustion Air blockage.	<ul style="list-style-type: none"> • Check the vent and combustion air pipes for blockage. • Verify operation of the backflow flapper in the fan outlet.
F019	Boiler Memory Module (BMM) fault.	<ul style="list-style-type: none"> • Verify wire harness connections at boiler memory module and control module are tight. • Verify wire harness continuity between boiler memory module and control module . • Replace boiler memory module.
F021	Critical parameter changed	<ul style="list-style-type: none"> • Factory reset required.
F027	Outdoor temperature sensor short.	<ul style="list-style-type: none"> • Check resistance of outdoor temperature sensor, replace sensor if short circuit is found. • Check resistance of outdoor temperature sensor at control module harness connector, repair outdoor sensor field wiring if short circuit is found.
F028	Reset button fault.	<ul style="list-style-type: none"> • Check the reset button for unintentional operation such as during cleaning. • Replace control module.
F029	Gas valve fault.	<ul style="list-style-type: none"> • Verify wire harness connections at gas valve and control module are tight. • Replace gas valve if upper coil resistance is not 35 to 45 Ω. • Replace gas valve if lower coil resistance is not 20 to 30 Ω. • Check resistance of gas valve at control module harness connector, repair wire harness if open/short circuit is found or if resistance is not within 60 to 70 Ω. • Replace control module.
F031	Supply temperature sensor open/short.	<ul style="list-style-type: none"> • Verify wire harness connections at supply temperature sensor and control module are tight. • Check resistance of supply temperature sensor, replace sensor if open/short circuit is found. • Check resistance of supply temperature sensor at control module harness connector, repair wire harness if open/short circuit is found.
F040	Cabinet temperature sensor open.	<ul style="list-style-type: none"> • Verify wire harness connections at cabinet temperature sensors and control module are tight. • Check resistance of cabinet temperature sensors, replace sensor if open circuit is found. • Check resistance of cabinet temperature sensors at control module harness connector, repair wire harness if open circuit is found.

F041	Cabinet temperature sensor short.	<ul style="list-style-type: none"> • Check resistance of cabinet temperature sensors, replace sensor if short circuit is found. • Check resistance of cabinet temperature sensors at control module harness connector, repair wire harness if short circuit is found.
F042	Cascade DHW not available	<ul style="list-style-type: none"> • Resolve any other lockouts in the cascade system. • Verify Leader cascade parameter settings are correct. • Verify Follower(s) cascade parameter settings are correct. • Check cascade communication status in the information menu of both Leader and Follower.
-- (Blinking)	Water pressure sensor fault.	<ul style="list-style-type: none"> • Verify wire harness connections at water pressure sensor and control module are tight. • Check resistance of water pressure sensor at control module harness connector: Black - Orange = 7.5 to 9.5 KΩ Black - Yellow = 7.5 to 9.5 KΩ • If any resistance value is outside of these ranges, check and repair wire harness open/short circuit before replacing water pressure sensor.

5.3.2 Notification Codes

During operation the controller can also detect unusual situations and display a notification, usually without significant interruption of the normal operation of the appliance.

These notifications are shown on the main display, and display only when an unusual reading is currently detected. Once the error has been resolved, the operation will be restored

Note that these notifications only appear on controllers installed with software versions after 1.80. The software version of the controller will appear upon the controller's initial start up.

NOTIFICATION CODE	DESCRIPTION	POSSIBLE CAUSE / SOLUTION
n030	DHW outlet temperature sensor open/short	<ul style="list-style-type: none"> • Verify wire harness connections at DHW outlet temperature sensor and control module are tight. • Check resistance of DHW outlet temperature sensor, replace sensor if open/short circuit is found. • Check resistance of DHW outlet temperature sensor at control module harness connector, repair wire harness if open/short circuit is found.
n040	Cascade communication lost	<ul style="list-style-type: none"> • Verify Leader is powered on and cascade parameter settings are correct. • Verify Follower(s) cascade parameter settings are correct. • Check cascade communication status in the information menu of both Leader and Follower.

n041	Cascade system sensor open	<ul style="list-style-type: none"> • Verify system sensor field wiring is terminated at the chosen input (X13-3&4 or X13-4&5). • Check resistance of system temperature sensor, replace sensor if open circuit is found. • Check resistance of system temperature sensor at control module harness connector, repair system sensor field wiring if open circuit is found.
n120	Maintenance recommended	<ul style="list-style-type: none"> • Maintenance is recommended based on hours of use.
n121	Maintenance required, limited DHW output	<ul style="list-style-type: none"> • Maintenance is required based on hours of use. • DHW output will be limited until maintenance is performed.
n122	Maintenance required, no DHW output	<ul style="list-style-type: none"> • Maintenance is required based on hours of use. • DHW output is disabled until maintenance is performed.
n150	High heat exchanger temperature, limited output	<ul style="list-style-type: none"> • Verify all air has been bled/purged from the heat exchanger central heating coil. • Replace internal pump if it is not operating during a central heating demand. • Verify the unit has been converted to propane if operating on propane. • Verify combustion readings at low and high fire are within specifications. • Clean fire side of heat exchanger. • Clean heat exchanger central heating and DHW coils.
n151	High flue temperature, limited output	<ul style="list-style-type: none"> • Verify the unit has been converted to propane if operating on propane. • Verify combustion readings at low and high fire are within specifications. • Clean fire side of heat exchanger. • Clean heat exchanger central heating and DHW coils.
n152	Flue temperature sensor mounting fault	<ul style="list-style-type: none"> • Flue temperature is not changing while unit is fired. • Verify flue temperature sensor is properly mounted on the vent pipe.
n201	Heat exchanger air purge function activated	<ul style="list-style-type: none"> • Air trapped in the heat exchanger • Closed boiler isolation valve • Defective boiler pump
n202	High flue temperature, burner disabled	<ul style="list-style-type: none"> • Verify the unit has been converted to propane if operating on propane. • Verify combustion readings at low and high fire are within specifications. • Clean fire side of heat exchanger • Clean heat exchanger central heating and DHW coils.
n245	Flue gas back flow, fan on low speed	<ul style="list-style-type: none"> • Verify vent and combustion air piping and terminations are installed according to this manual. • Verify operation of the backflow flapper in the fan outlet.

5.4 OTHER FAULTS

5.4.1 No heat (space heating)

POSSIBLE CAUSES	ANALYSIS	POSSIBLE SOLUTION
The power LED is not shown.	→ Yes ↓No	<ul style="list-style-type: none"> • Check the power supply. • Check the fuse (see Electrical schematic). • Check wiring for breaks.
The right display shows a line (-). The unit is off.	→ Yes ↓No	<ul style="list-style-type: none"> • Switch on the unit by touching just above the power LED and holding for 2 seconds.
Room thermostat / zone control not enabling unit.	→ Yes ↓No	<ul style="list-style-type: none"> • Check the wiring. Verify room thermostat / zone control is providing dry contact to enable unit for space heating.
No electricity (24V).	→ Yes	<ul style="list-style-type: none"> • Check the wiring according to the schematic. • Check Connector X13.

5.4.2 Space heating does not reach the correct temperature

POSSIBLE CAUSES	ANALYSIS	POSSIBLE SOLUTION
Water pressure in the system is too low.	→ Yes ↓No	Top up the system.
Room thermostat is not calling for heat.	→ Yes ↓No	Check the setting and adjust it if necessary.
Temperature is set too low.	→ Yes ↓No	Increase the space heating temperature (see 2.3.2). If an outdoor sensor is present. Check the outdoor sensor.
No flow in the system.	→ Yes ↓No	Check the $\Delta T \pm 36^{\circ}\text{F} / \pm 20^{\circ}\text{C}$ between the central heating supply and the return. Ensure a correct flow in the system.
The unit's capacity is not correctly set.	→ Yes ↓No	Adjust the unit's capacity.
No heat transfer due to contamination in the unit/system.	→ Yes ↓No	Flush the unit/system.
Flue and/or air supply duct is blocked.	→ Yes	Check and (if necessary) clean the flue and the air supply duct.

5.4.3 Space heating system remains too warm

POSSIBLE CAUSES	ANALYSIS	POSSIBLE SOLUTION
Room thermostat / zone control is defective or has a short circuit.	→ Yes ↓No	<ul style="list-style-type: none"> Check the wiring. Check room thermostat / zone control for a short circuit.
There is thermo-siphon in the central heating circuit.	→ Yes	Place a check valve (in the case of thermo-siphon) or a two-way valve (if there is a second pump in the central heating circuit).

5.4.4 Burner ignites loudly

POSSIBLE CAUSES	ANALYSIS	SOLUTION
Inlet pressure is too high.	→ Yes ↓No	The gas pressure regulator may be defective. In that case, contact the energy company.
Ignition distance is incorrect.	→ Yes ↓No	Replace the ignitor including the ignition cable.
Gas-air control is not correctly adjusted.	→ Yes	Check and/or adjust combustion with a calibrated combustion analyzer.

5.4.5 Burner resonates

POSSIBLE CAUSES	ANALYSIS	SOLUTION
Gas inlet pressure lower than 4" w.c. or sometimes disappears.	→ Yes ↓No	The gas pressure regulator may be defective. Contact the energy company.
There is recirculation of flue gases.	→ Yes ↓No	Check the flue and air supply duct.
Gas-air control is not correctly adjusted.	→ Yes ↓No	Check and/or adjust combustion with a calibrated combustion analyzer.
Burner seal is defective.	→ Yes ↓No	Replace the burner seal.
Burner is defective.	→ Yes	Replace the burner.

6.0 REPLACEMENT KITS

Replacement Kit Numbers	Replacement Kit Description	99,000	120,000
P-081034	<i>Conversion To Propane - Venturi 528</i>	x	
P-081044	<i>Conversion To Natural Gas - Venturi 528</i>	x	
P-081054	<i>Conversion To Propane - Venturi 500</i>		x
P-081064	<i>Conversion To Natural Gas - Venturi 500</i>		x
P-081364	<i>Conversion To Low Calorific Gas - Venturi 528</i>	x	
P-081374	<i>Conversion To Low Calorific Gas - Venturi 500</i>		x
P-081134	<i>Replacement kit: Flue Temperature Sensor</i>	x	x
P-081144	<i>Replacement kit: Ignitor</i>	x	x
P-081154	<i>Replacement kit: Burner 99 - 125</i>	x	x
P-081174	<i>Replacement kit: EBM Fan</i>	x	x
P-081224	<i>Replacement kit: Boiler Pump</i>	x	x
P-081234	<i>Replacement kit: Gas Valve</i>	x	x
P-081294	<i>Replacement kit: Temperature Sensor Heat Exchanger</i>	x	x
P-081314	<i>Replacement kit: Pressure Sensor</i>	x	x
P-081334	<i>Replacement kit: Controller Box White</i>	x	x
P-081504	<i>Replacement kit: Ignition Wiring</i>	x	x
P-081574	<i>Replacement kit: Ignition Line Complete</i>	x	x
P-081654	<i>Replacement kit: Condensate Trap Boiler</i>	x	x
P-081694	<i>Replacement kit: Temperature Sensor Supply (Clip 22mm)</i>	x	x
P-081794	<i>Replacement kit: Controller Box Black</i>	x	x

This page is intentionally left blank.

7.0 WIRING DIAGRAMS

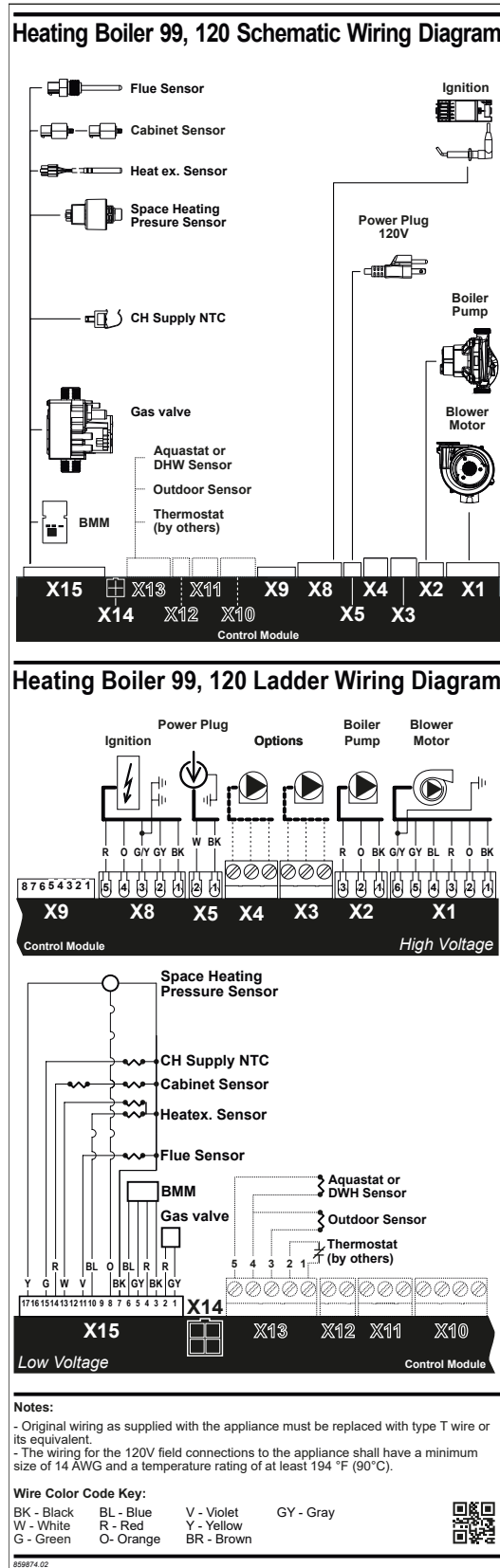

Diagram 6.2-1: Schematic wiring diagram

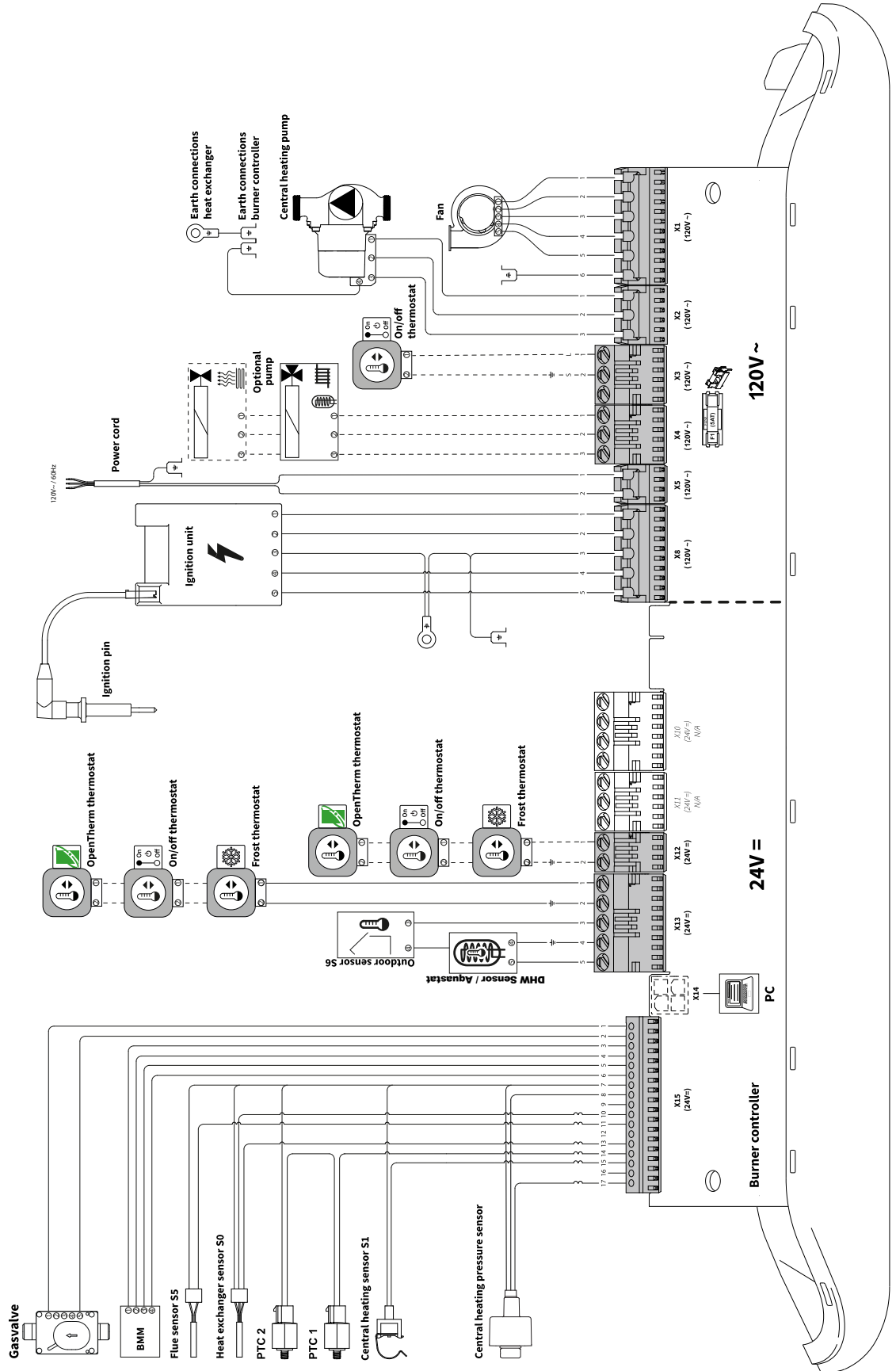

Diagram 6.2-2: Electrical wiring diagram

INSTALLATION & COMMISSIONING REPORT

Unit Details:

Model Number _____ Serial Number _____

Date of Installation _____ Address of installation _____

User contact information _____

Installer Information Company _____

Address _____

Phone/Fax/E mail _____

Fuel Natural Gas Propane

Gas Supply Pressure (high fire) _____ Inches w.c. Measured Rate of Input (high fire) _____ Btu/hr

Installation instructions have been followed and completed (Section 1 of Installation and Operating Instructions).

Check-out procedures have been followed and completed (Section 3 of Installation and Operating Instructions).

Leak testing completed gas piping venting system Fan and combustion components

System Cleaned and Flushed (type of cleaner used) _____

System Filled (type/concentration of any glycol/chemicals used) _____

Air purge completed

Relief Valve correctly installed and piped Relief valve "try lever" test performed

Condensate trap filled Condensate drain clear and free flowing Condensate Neutralization? Yes/No

Ignition Safety Shutoff test completed. Flame current reading - High fire _____ μ A - Low fire _____ μ A

Owner advised and instructed in the safe operation and maintenance of the unit and system.

Information regarding the unit and installation received and left with owner

Combustion Readings - recommended, but optional (required for fuel conversion):

CO₂ _____ % O₂ _____ % CO _____ ppm

Flue temperature _____ Return water temperature (measure simultaneously with flue temp.) _____

Commissioning has been completed as listed on this report - Installer Signature _____

This installation & commissioning report should remain with the Heating boiler for future reference during maintenance and repair.

IMPORTANT

This unit is equipped with a feature that saves energy by reducing the unit's water temperature as the heating load decreases. This feature is equipped with an override which is provided primarily to permit the use of an external energy management system that serves the same function. **THIS OVERRIDE MUST NOT BE USED UNLESS AT LEAST ONE OF THE FOLLOWING CONDITIONS IS TRUE:**

- An external energy management system is installed that reduces the unit's water temperature as the heating load decreases.
- This unit is not used for any space heating.
- This unit is part of a modular or multiple unit system having a total input of 300,000 BTU/hr or greater.
- This unit is equipped with a tankless coil.

NOTES

This page is intentionally left blank.



84154404

Rheem Sales Co.

Montgomery, AL.

(833) 212-9276

IBC Technologies Inc.

8015 North Fraser Way

Burnaby, BC Canada V5J 5M8

(844) HEAT-IBC / (844) 432-8422

IBC Technologies USA Inc.

121 Walter A Gaines Way

Lawnside, NJ 08045

(856) 887-0544

May 2023 ©