







**RPCY STANDARD FEATURES INCLUDE:**

- Factory charged with nitrogen for shipping
- Ready to be charged with R-454B refrigerant in the field after installation
- Wired and run tested
- Scroll compressors with internal line break overload and high pressure protection
- High and Low Pressure switches provide additional system protection
- Forkable base rails on 10 Ton for easy handling and lifting
- Cooling operation up to 125°F ambient
- Tube and Fin condenser and evaporator coils
- Single-piece control door
- 7.5 and 10 Ton includes a single Two-Stage scroll compressor

**ACCESSORIES**

ACCESSORY DESCRIPTION	MODEL NUMBER	SIZE USED ON
Low Ambient Control	RXAD-A08	ALL

## UNIT DIMENSIONS AND WEIGHTS 7.5 TON [26.4 kW]

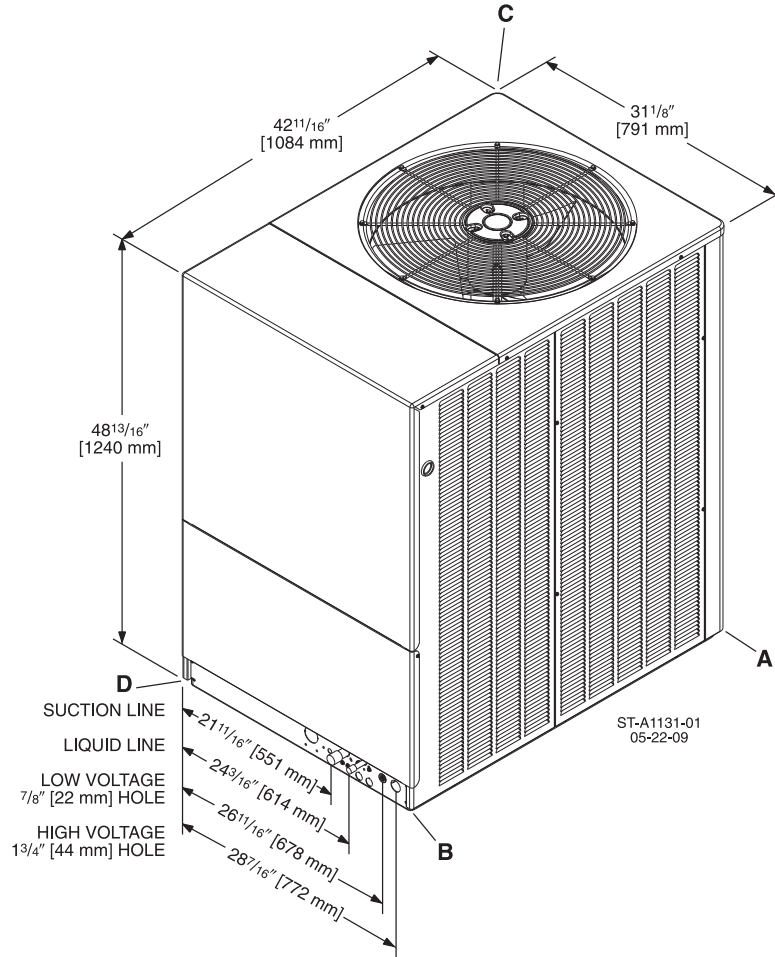

### 7.5 TON [26.4 kW]

MODEL	TOTAL WEIGHT LBS. [kg]	CORNER WEIGHTS, LBS. [kg]			
		A	B	C	D
RPCY2090	428 [194.1]	75 [34]	107 [49]	79 [36]	167 [78]

[ ] Designates Metric Conversions

## UNIT DIMENSIONS AND WEIGHTS 10 TON [35.2 kW]

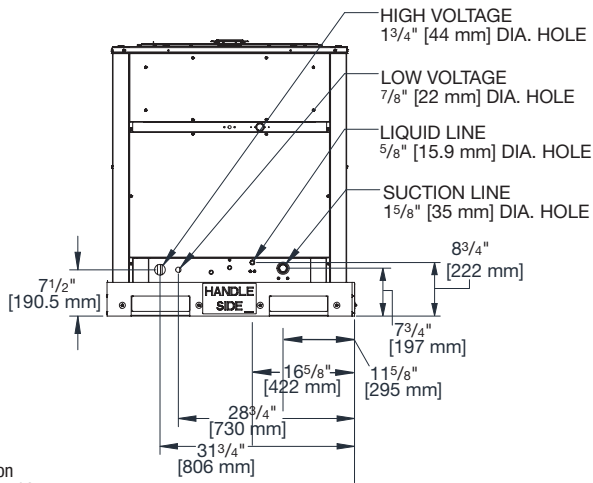
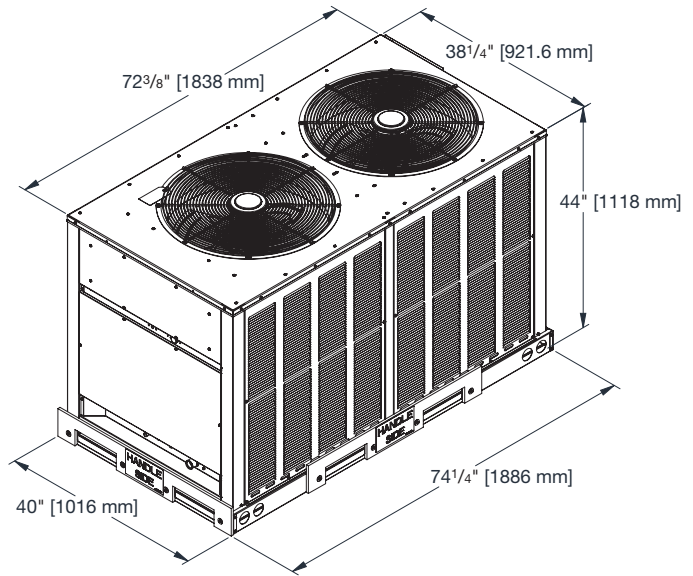

Illustration  
ST-A1377-02



## 10 TON [35.2 kW]

MODEL	TOTAL WEIGHT LBS. [kg]	CORNER WEIGHTS, LBS. [kg]			
		A	B	C	D
RPCY2120	642 [291]	167 [76]	154 [70]	167 [76]	154 [70]

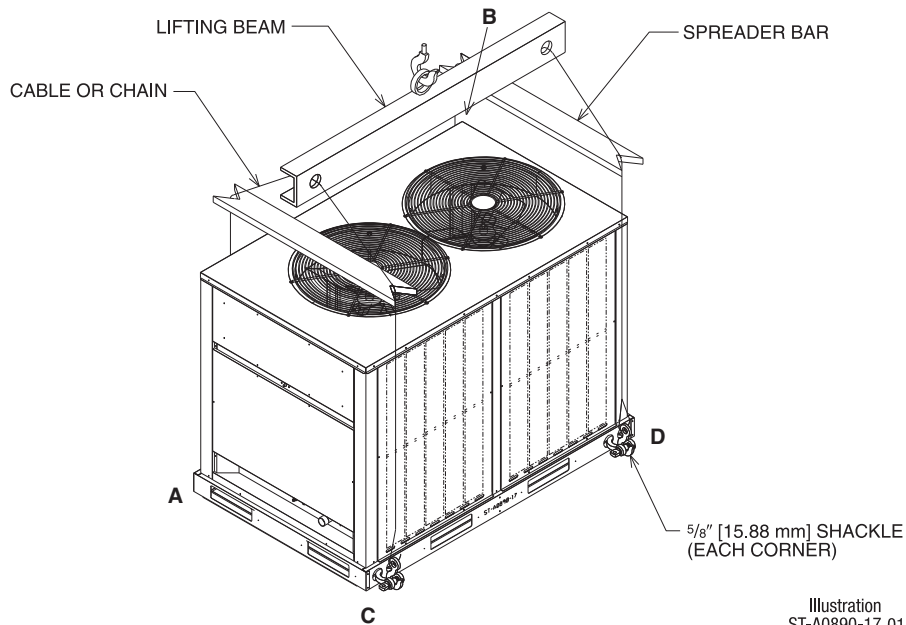

Illustration  
ST-A0890-17-01

[ ] Designates Metric Conversions