



Endeavor® Line Select™ Series iC Heat Pumps



WSP14AZ

Cooling Efficiencies up to: 14.3 SEER2 / 10.4 EER2

Heating Efficiencies up to: 7.5 HSPF2

Nominal Sizes: 1.5 to 2.5 Tons [5.28 to 8.79 kW]

Cooling & Heating Capacities: 17.1 to 55.5 kBTU [5.0 to 16.3 kW]

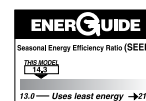

Table of Contents

Features and Benefits	3
Model Number Identification	4
General Data/Electrical Data	5
Accessories	6
Weighted Sound Power	6
Unit Dimensions	7
Clearances	8
Refrigerant Line Size Information	9-10
Performance Data	11
Limited Warranty	12

Features and Benefits

- **Fully Louvered Steel Cabinet:** Features durable construction to add protection from yard hazards, weather corrosion
- **Two-Stage Scroll Compressor:** Features two speeds (high and low) of cooling and heating, providing more precise temperature control, lower humidity and greater efficiency when compared to single stage compressors
- **Optimized 7mm Coil Design:** Allows for improved airflow, heat transfer and energy consumption
- **Easily Accessible Control Box:** Ease of installation and serviceability

Heat Pumps

<u>W</u>	<u>SP</u>	<u>14</u>	<u>A</u>	<u>Z</u>	<u>18</u>	<u>A</u>	<u>J</u>	<u>2</u>	<u>N</u>	<u>A</u>
Brand	Product Category	SEER2	Region	Refrigerant	Capacity	Major Series	Voltage	Type	Controls	Minor Series
W - Rheem	SP - Legacy Heat Pump	14 - 14.3 SEER2	A - All Regions	Z - R-410A	18 - 18,000 [5.28 kW] 24 - 24,000 [7.03 kW] 30 - 30,000 [8.79 kW]	A - 1st Design	J - 208/230/1/60	2 - 2-Stage	N - Non-Communicating	A - 1st Design

[] Designates Metric Conversions

AVAILABLE MODELS	DESCRIPTION
WSP14AZ18AJ2NA	1-1/2 ton 14.3 SEER2 Two-Stage Air Conditioner-208/230/1/60
WSP14AZ24AJ2NA	2 ton 14.3 SEER2 Two-Stage Air Conditioner-208/230/1/60
WSP14AZ30AJ2NA	2-1/2 ton 14.3 SEER2 Two-Stage Air Conditioner-208/230/1/60

STANDARD EQUIPMENT
R-410A Refrigerant
Scroll Compressor
Field Installed Filter Drier
Front Seating Service Valves
Internal Pressure Relief Valve
Internal Thermal Overload
Long Line capability
Low Ambient capability with Kit
3-4-5 Expanded Valve Space
Optimized Venturi Airflow
Single row condenser coil
Rust resistant screws
QR code
External gauge ports
Service trays

General Data			
MODEL NO.	WSP14AZ18A	WSP14AZ24A	WSP14AZ30A
Nominal Tonnage	1.5	2.0	2.5
Valve Connections			
Liquid Line O.D. – in.	3/8	3/8	3/8
Suction Line O.D. – in.	3/4	3/4	3/4
Refrigerant (R-410A) furnished oz.¹	88	103	127
Compressor Type	Scroll		
Outdoor Coil			
Net face area – Outer Coil	14.5	14.5	18.1
Tube diameter – in.	0.276	0.276	0.276
Number of rows	1	1	1
Fins per inch	22	22	22
Outdoor Fan			
Diameter – in.	18	18	22
Number of blades	3	3	2
Motor hp	1/7	1/7	1/6
CFM	2181	2181	2514
RPM	1075	1075	850
Watts	154	154	165
Shipping weight – lbs.	143	145	170
Operating weight – lbs.	135	137	163

Electrical Data			
Line Voltage Data (Volts-Phase-Hz)	208/230-1-60	208/230-1-60	208/230-1-60
Maximum overcurrent protection (amps)²	20	25	25
Minimum circuit ampacity³	11	15	16
Compressor			
Rated load amps	9	11	13
Locked rotor amps	56	66	78
Condenser Fan Motor			
Full load amps	0.8	0.8	1.0
Locked rotor amps	1.5	1.5	2.6

¹Refrigerant charge sufficient for 15 ft. length of refrigerant lines. For longer line set requirements see the installation instructions for information about set length and additional refrigerant charge required.

²HACR type circuit breaker or fuse.

³Refer to National Electrical Code manual to determine wire, fuse and disconnect size requirements.

Accessories

MODEL NO.		WSA14AZ18A	WSA14AZ24A	WSA14AZ30A
Compressor crankcase heater*		44-17402-44	44-17402-44	44-17402-44
Low ambient control		RXAD-A08	RXAD-A08	RXAD-A08
Compressor sound cover		68-23427-26	68-23427-26	68-23427-26
Compressor hard start kit		SK-A1	SK-A1	SK-A1
Compressor time delay		RXMD-B01	RXMD-B01	RXMD-B01
Low pressure control		RXAC-A07	RXAC-A07	RXAC-A07
High pressure control		RXAB-A07	RXAB-A07	RXAB-A07
Liquid Line Solenoid (24 VAC, 50/60 Hz)	Solenoid Valve	200RD2T3TVLC	200RD2T3TVLC	200RD2T3TVLC
	Solenoid Coil	61-AMG24V	61-AMG24V	61-AMG24V
Liquid Line Solenoid (120/240 VAC, 50/60 Hz)	Solenoid Valve	200RD2T3TVLC	200RD2T3TVLC	200RD2T3TVLC
	Solenoid Coil	61-AMG120/240V	61-AMG120/240V	61-AMG120/240V

*Bi-flow kits are required when installing a liquid line solenoid on a heat pump.

Weighted Sound Power Level (dBA)

UNIT SIZE - VOLTAGE, SERIES	STANDARD RATING (DBA)	TYPICAL OCTAVE BAND SPECTRUM (dBA without tone adjustment)						
		125	250	500	1000	2000	4000	8000
WSP14AZ18AJ2	73	47.8	51.7	60.8	65.5	61.7	56.4	48.6
WSP14AZ24AJ2	74	125.0	53.0	60.0	67.0	58.6	55.5	47.6
WSP14AZ30AJ2	76	49.6	67.7	63.4	68.6	62.1	63.7	50.8

NOTE: Tested in accordance with AHRI Standard 270-08 (not listed in AHRI)

Unit Dimensions

MODEL NO.	OPERATING						SHIPPING					
	H (Height)		L (Length)		W (Width)		H (Height)		L (Length)		W (Width)	
	INCHES	mm	INCHES	mm	INCHES	mm	INCHES	mm	INCHES	mm	INCHES	mm
WSP14AZ18A	35.38	899	23.63	600	23.63	600	35.63	905	24.75	629	24.75	629
WSP14AZ24A	35.38	899	23.63	600	23.63	600	35.63	905	24.75	629	24.75	629
WSP14AZ30A	35.38	899	27.63	702	27.63	702	35.63	905	28.75	730	28.75	730

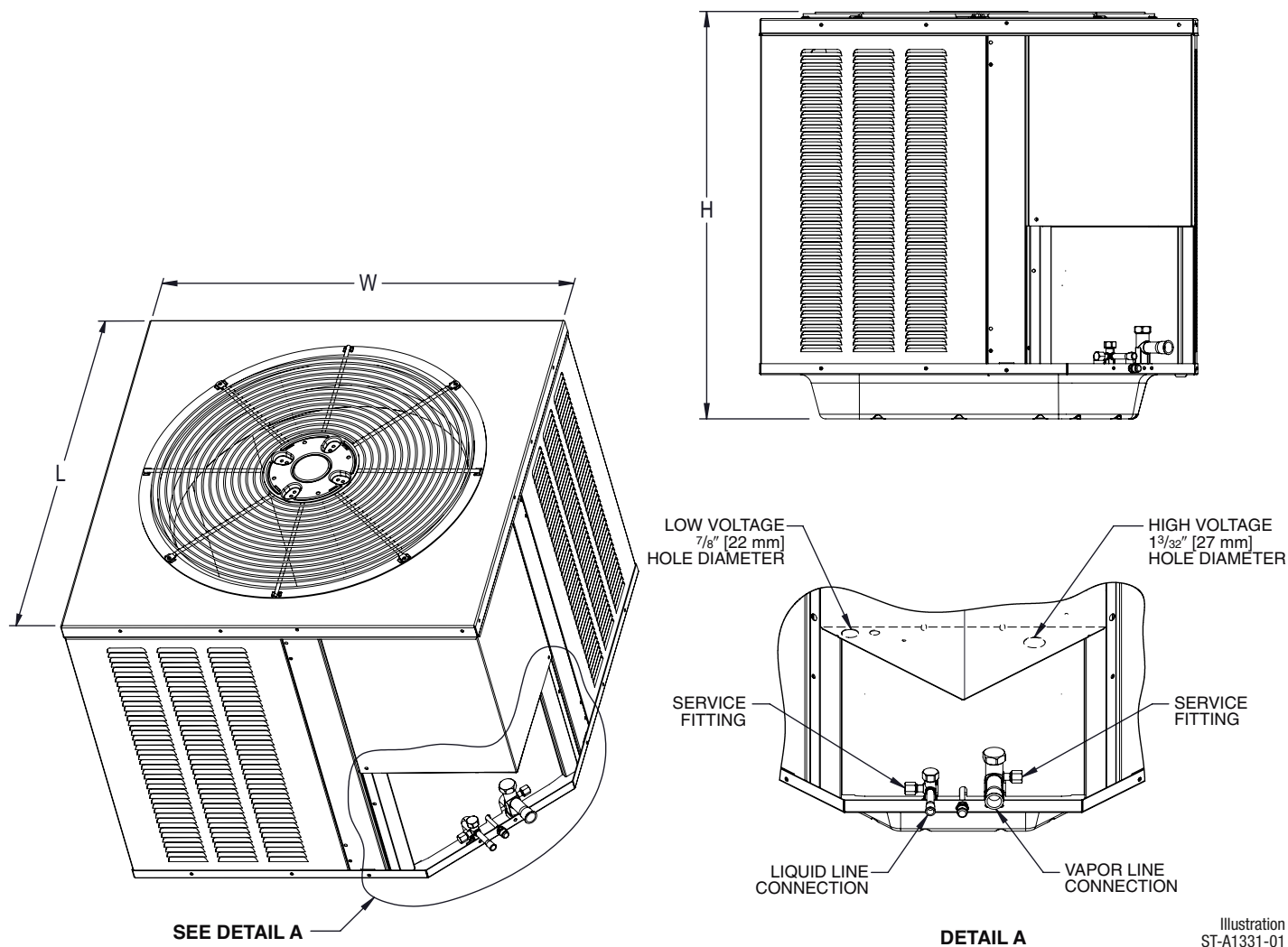
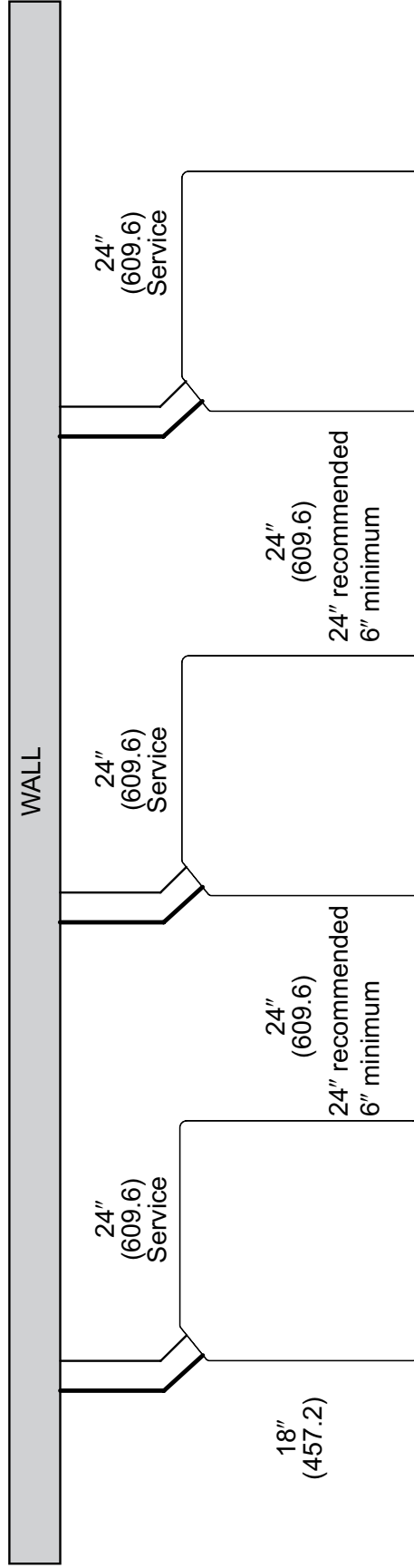
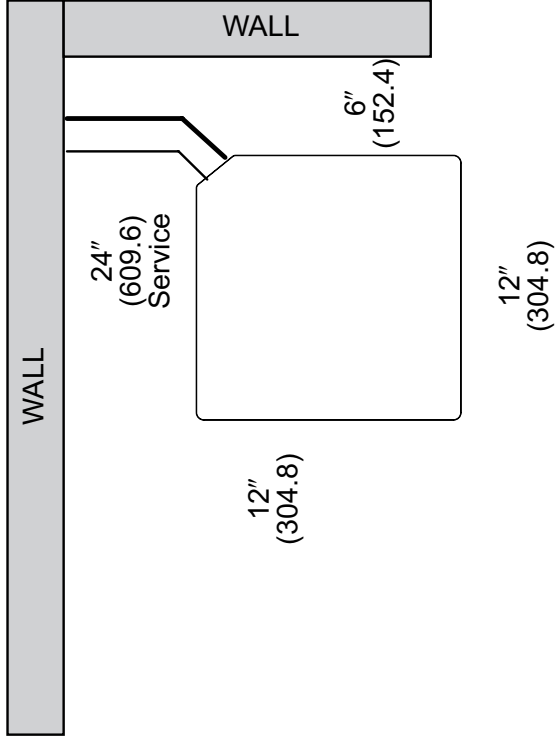
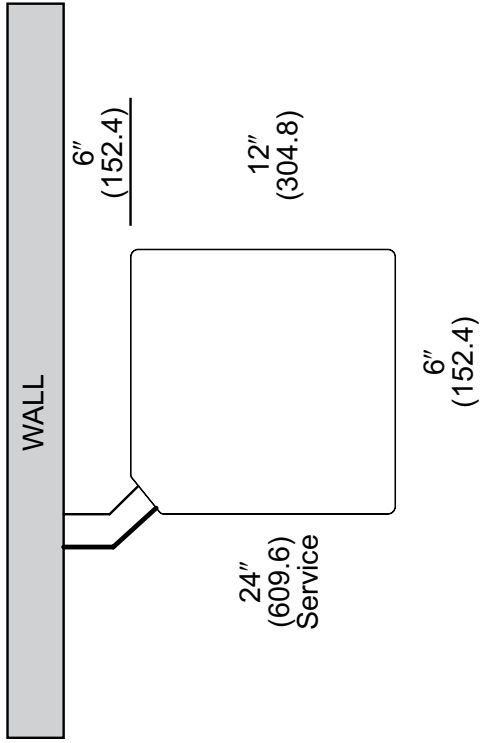

Illustration
ST-A1331-01
Rev. 10-20-2022

[] Designates Metric Conversions

CLEARANCES



NOTE: NUMBERS IN () = mm

IMPORTANT: When installing multiple units in an alcove, roof well or partially enclosed area, ensure there is adequate ventilation to prevent re-circulation of discharge air.

Refrigerant Line Size Information

14.3 SEER2 SINGLE-STAGE AIR-CONDITIONERS													
UNIT SIZE	Allowable Liquid Line Size	Allowable Suction Line Size	Apply Long Line Guidelines if Linear Line Length Exceeds Those Shown Below (Feet)	Equivalent Length (Feet)									
				< 25	26-50	51-75	76-100	101-125	126-150	151-175	176-200	201-225	226-250
				Maximum Vertical Rise (Outdoor Unit Below Indoor Unit) * / Capacity Multiplier									
1.5 Ton **SEE NOTE 3	1/4"	5/8"	/	25 / 1.00	50 / 0.99	62 / 0.98	43 / 0.98	24 / 0.97	5 / 0.97	NR	NR	NR	NR
	5/16"	5/8"	188	25 / 1.00	50 / 0.99	75 / 0.98	98 / 0.98	93 / 0.97	88 / 0.97	83 / 0.96	78 / 0.96	73 / 0.95	68 / 0.94
	3/8"	5/8"	125	25 / 1.00	50 / 0.99	75 / 0.98	100 / 0.98	100 / 0.97	100 / 0.97	100 / 0.96	100 / 0.96	100 / 0.95	100 / 0.94
	1/4"	3/4" **	/	25 / 1.00	50 / 1.00	62 / 0.99	43 / 0.99	24 / 0.99	5 / 0.99	NR	NR	NR	NR
	5/16"	3/4" **	188	25 / 1.00	50 / 1.00	75 / 0.99	98 / 0.99	93 / 0.99	88 / 0.99	83 / 0.99	78 / 0.98	73 / 0.98	68 / 0.98
	3/8"	3/4" **	125	25 / 1.00	50 / 1.00	75 / 1.00	100 / 0.99	100 / 0.99	100 / 0.99	100 / 0.99	100 / 0.98	100 / 0.98	100 / 0.98
2 Ton	1/4"	5/8"	/	25 / 0.99	50 / 0.98	21 / 0.97	NR	NR	NR	NR	NR	NR	NR
	5/16"	5/8"	180	25 / 0.99	50 / 0.98	75 / 0.97	87 / 0.96	77 / 0.95	69 / 0.94	61 / 0.93	53 / 0.92	45 / 0.91	37 / 0.90
	3/8"	5/8"	120	25 / 0.99	50 / 0.98	75 / 0.97	100 / 0.96	100 / 0.95	100 / 0.94	98 / 0.93	95 / 0.92	92 / 0.91	89 / 0.90
	1/4"	3/4"	/	25 / 1.00	50 / 1.00	21 / 0.99	NR	NR	NR	NR	NR	NR	NR
	5/16"	3/4"	180	25 / 1.00	50 / 1.00	75 / 0.99	87 / 0.99	77 / 0.98	69 / 0.98	61 / 0.98	53 / 0.97	45 / 0.97	37 / 0.96
	3/8"	3/4"	120	25 / 1.00	50 / 1.00	75 / 0.99	100 / 0.99	100 / 0.98	100 / 0.98	98 / 0.98	95 / 0.97	93 / 0.97	90 / 0.96
2.5 Ton	5/16"	5/8"	148	25 / 0.99	50 / 0.98	75 / 0.96	70 / 0.94	59 / 0.93	48 / 0.91	36 / 0.90	NR	NR	NR
	3/8"	5/8"	98	25 / 0.99	50 / 0.98	75 / 0.96	100 / 0.94	98 / 0.93	94 / 0.91	90 / 0.90	NR	NR	NR
	5/16"	3/4"	148	25 / 1.00	50 / 0.99	75 / 0.99	70 / 0.98	59 / 0.98	48 / 0.97	36 / 0.96	25 / 0.96	13 / 0.95	NR
	3/8"	3/4"	98	25 / 1.00	50 / 0.99	75 / 0.99	100 / 0.98	98 / 0.98	94 / 0.97	90 / 0.96	86 / 0.96	82 / 0.95	78 / 0.95

- 1) Do not exceed 200 ft linear line length.
- 2) *Do not exceed 100 ft vertical separation if outdoor unit is above indoor unit.
- 3) **3/4" suction line should only be used for 1.5 ton systems if outdoor unit is below or at same level as indoor to assure proper oil return.
- 4) Always use the smallest liquid line allowable to minimize refrigerant charge.
- 5) Applications shaded in light gray indicate capacity multipliers between 0.90 and 0.96 which are not recommended, but are allowed.
- 6) Applications shaded in dark gray are not recommended due to excessive liquid or suction pressure drop.

Refrigerant Line Size Information (Con't.)

14.3 SEER2 SINGLE-STAGE AIR-CONDITIONERS													
Unit Size	Allowable Liquid Line Size mm [in.]	Allowable Suction Line Size mm [in.]	Apply Long Line Guidelines if Linear Line Length Exceeds Those Shown Below (Meters)	Equivalent Length (Meters)									
				< 8	8-15	16-23	24-30	31-38	39-46	47-53	54-61	62-69	70-76
				Maximum Vertical Rise (Outdoor Unit Below Indoor Unit) * / Capacity Multiplier									
5.3 KW [1.5 Ton] **SEE NOTE 3	6.35 [1/4]	15.88 [5/8]	/	8 / 1.00	15 / 0.99	19 / 0.98	13 / 0.98	7 / 0.97	2 / 0.97	NR	NR	NR	NR
	7.94 [5/16]	15.88 [5/8]	57	8 / 1.00	15 / 0.99	23 / 0.98	30 / 0.98	28 / 0.97	27 / 0.97	25 / 0.96	24 / 0.96	22 / 0.95	21 / 0.94
	9.53 [3/8]	15.88 [5/8]	38	8 / 1.00	15 / 0.99	23 / 0.98	30 / 0.98	30 / 0.97	30 / 0.97	30 / 0.96	30 / 0.96	30 / 0.95	30 / 0.94
	6.35 [1/4]	19.05 [3/4]**	/	8 / 1.00	15 / 1.00	19 / 0.99	13 / 0.99	7 / 0.99	2 / 0.99	NR	NR	NR	NR
	7.94 [5/16]	19.05 [3/4]**	57	8 / 1.00	15 / 1.00	23 / 0.99	30 / 0.99	28 / 0.99	27 / 0.99	25 / 0.99	24 / 0.98	22 / 0.98	21 / 0.98
	9.53 [3/8]	19.05 [3/4]**	38	8 / 1.00	15 / 1.00	23 / 0.99	30 / 0.99	30 / 0.99	30 / 0.99	30 / 0.99	30 / 0.99	30 / 0.98	30 / 0.98
7.0 KW [2 Ton]	6.35 [1/4]	15.88 [5/8]	/	8 / 0.99	15 / 0.98	6 / 0.97	NR	NR	NR	NR	NR	NR	NR
	7.94 [5/16]	15.88 [5/8]	55	8 / 0.99	15 / 0.98	23 / 0.97	27 / 0.96	23 / 0.95	21 / 0.94	19 / 0.93	16 / 0.92	14 / 0.91	11 / 0.90
	9.53 [3/8]	15.88 [5/8]	37	8 / 0.99	15 / 0.98	23 / 0.97	30 / 0.96	30 / 0.95	30 / 0.94	30 / 0.93	29 / 0.92	28 / 0.91	27 / 0.90
	6.35 [1/4]	19.05 [3/4]	/	8 / 1.00	15 / 1.00	6 / 0.99	NR	NR	NR	NR	NR	NR	NR
	7.94 [5/16]	19.05 [3/4]	55	8 / 1.00	15 / 1.00	23 / 0.99	27 / 0.99	23 / 0.98	21 / 0.98	19 / 0.98	16 / 0.97	14 / 0.97	11 / 0.96
	9.53 [3/8]	19.05 [3/4]	37	8 / 1.00	15 / 1.00	23 / 0.99	30 / 0.99	30 / 0.98	30 / 0.98	30 / 0.98	29 / 0.97	28 / 0.97	27 / 0.96
8.8 KW [2.5 Ton]	7.94 [5/16]	15.88 [5/8]	45	8 / 0.99	15 / 0.98	23 / 0.96	21 / 0.94	18 / 0.93	15 / 0.91	11 / 0.90	NR	NR	NR
	9.53 [3/8]	15.88 [5/8]	30	8 / 0.99	15 / 0.98	23 / 0.96	30 / 0.94	30 / 0.93	29 / 0.91	27 / 0.90	NR	NR	NR
	7.94 [5/16]	19.05 [3/4]	45	8 / 1.00	15 / 0.99	23 / 0.99	21 / 0.98	18 / 0.98	15 / 0.97	11 / 0.96	8 / 0.96	4 / 0.95	NR
	9.53 [3/8]	19.05 [3/4]	30	8 / 1.00	15 / 0.99	23 / 0.99	30 / 0.98	30 / 0.98	29 / 0.97	27 / 0.96	26 / 0.96	25 / 0.95	24 / 0.95

- 1) Do not exceed 61m linear line length.
- 2) *Do not exceed 30m vertical separation if outdoor unit is above indoor unit.
- 3) **19mm suction line should only be used for 1.5 ton systems if outdoor unit is below or at same level as indoor to assure proper oil return.
- 4) Always use the smallest liquid line allowable to minimize refrigerant charge.
- 5) Applications shaded in light gray indicate capacity multipliers between 0.90 and 0.96 which are not recommended, but are allowed.
- 6) Applications shaded in dark gray are not recommended due to excessive liquid or suction pressure drop.

Performance Data @ AHRI Standard Conditions – Cooling

DESIGNATED TESTED COMBINATION (DTC)													
OUTDOOR UNIT	AIR HANDLER	TOTAL CAPACITY BTU/H [kW]	NET SENSIBLE BTU/H [kW]	NET LATENT BTU/H [kW]	SEER2	EER2	INDOOR CFM [L/S]	47 DEGREE HEATING CAPACITY BTU/H [kW]	47 DEGREE COP	17 DEGREE HEATING CAPACITY BTU/H [kW]	17 DEGREE COP	REGION IV HSPF2	
WSP14AZ18AJ2	RH2TZ2417STANNJ	17,100 [5.0]	12,800 [3.8]	4,300 [1.3]	14.3	9.0	585 [276.1]	17,100 [5.0]	3.45	11,000 [3.2]	2.38	7.5	
WSP14AZ24AJ2	RH2TZ2417STANNJ	22,800 [6.7]	16,600 [4.9]	6,200 [1.6]	14.3	9.0	735 [346.9]	22,800 [6.7]	3.45	15,000 [4.4]	2.48	7.5	
WSP14AZ30AJ2	RH2TZ3617STANNJ	28,500 [8.4]	21,300 [6.2]	7,200 [2.1]	14.3	9.0	910 [429.5]	28,500 [8.4]	3.45	18,000 [5.3]	2.50	7.5	

NOTE: This data includes DTC (Designated Test Combination) ratings and is for reference purposes only. A full listing of official ratings and system match-ups, along with downloadable certificates, can be accessed from the AHRI website: www.ahridirectory.org.

[] Designates Metric Conversions



GENERAL TERMS OF LIMITED WARRANTY*

Rheem will furnish a replacement for any part of this product which fails in normal use and service within the applicable period stated, in accordance with the terms of the limited warranty.

Conditional Parts
(Registration Required) Ten (10) Years

***For complete details of the Limited and Conditional Warranties, including applicable terms and conditions, contact your local contractor or the Manufacturer for a copy of the product warranty certificate.**

Before proceeding with installation, refer to installation instructions packaged with each model, as well as complying with all Federal, State, Provincial, and Local codes, regulations, and practices.

© 2025 Rheem Manufacturing Company. Rheem trademarks owned by Rheem Manufacturing Company.

In keeping with its policy of continuous progress and product improvement, Rheem reserves the right to make changes without notice.

5600 Old Greenwood Road
Fort Smith, Arkansas 72908 • www.rheem.com

125 Edgeware Road, Unit 1
Brampton, Ontario • L6Y 0P5 • rheem.ca