



The new degree of comfort.™

Commercial Heat Pump Air Handler



RHCLP Series

Nominal Size 7.5 & 10 Tons [26.4 & 35.2 kW]



TABLE OF CONTENTS

Unit Features.....	3
Model Number Identification	4
Component Location	5
Unit Dimensions	5
Physical Data/Drive Package Data	6
Airflow Performance	7-8
Performance Data	9-11
Electric Heater Kits and Electric Data.....	12
Piping.....	13
Accessories	14-15
Guide Specifications	16
Limited Warranty	17



CABINET—The pre-painted, sheet-metal cabinet uses 18-gauge material for structural components with an underlying coat of G60 electro deposition powder coating that is tested to withstand a rigorous 500-hour salt spray test, per ASTM B117.

MOTOR—Inherently protected motors are mounted inside of insulated cabinet to reduce motor noise. A choice of motor horsepower and drive combinations are available to allow you to meet specified CFM at various static pressures up to 2" [.498 kPa] external static pressure.

LOW PROFILE—Allows for horizontal installation in most standard drop ceiling applications, and the movement of units through most standard doorways for addition or replacement work.

THERMAL EXPANSION VALVES—Standard all models.

FILTERS—One inch [25 mm] throwaway filters are standard, but filter racks are designed to accept either one inch [25 mm] or two inch [51 mm] filters. MERV 13 & MERV 8 filters are available as an accessory.

EVAPORATOR COIL—Two circuit, interlaced row split coils are constructed with copper tubes and aluminum fins mechanically bonded to the tubes for maximum heat transfer capabilities. All coil assemblies are leak tested up to 450 PSIG [3100 kPa] internal pressure prior to installation into units. The RHCLP090 is designed with a slab coil. The RHCLP120 is designed with an A-coil.

REFRIGERANT CONNECTIONS—Field piping connections are made through a fixed post between two side access panels on either side of the unit. Allows flexibility to meet most field conditions as well as full accessibility after the installation is complete. Units may be used with two straight cool condensing units or single circuit manifolded in the field using the copper fittings shipped with each unit.

VARIABLE FREQUENCY DRIVE—Provides 2-stage airflow for improved part load efficiency. Meets California Title 24 requirements.

DRAIN PAN—The galvanized steel drain pan is designed to trap condensate in either vertical or horizontal installations. Condensate drain connections are located on both sides of the unit allowing complete flexibility to meet most field conditions.

SERVICE ACCESS—Two removable panels on top and each side of the unit are easily removed for access to motors, blowers, sheaves, and filters.

HORIZONTAL DISCHARGE—The air-handler may be installed in the horizontal discharge configuration with either a vertical or horizontal duct as shown below.

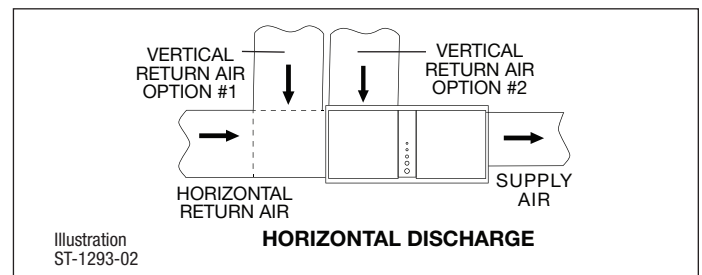

NOTE: The RHCLP2120 cannot be installed using the vertical return option #2

VERTICAL UP DISCHARGE—The air-handler may be installed in the vertical discharge configuration with a horizontal return duct as shown below.

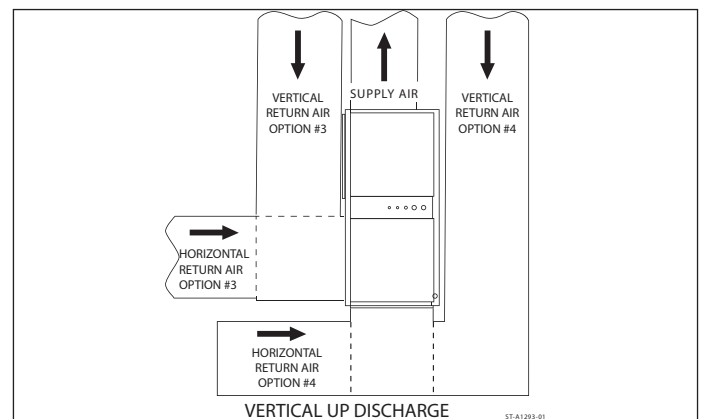

NOTE: The RHCLP210 cannot utilize the horizontal return air option #3 or the vertical return air option #3.

TESTING—All units are run tested at the factory prior to shipment. Units are shipped with a holding charge of nitrogen.

HEAT PUMP—The RHCLP Air Handler is designed for heat pump applications. It has two TX valves with internal check valves that allow reverse flow to occur, providing superior control during heating and cooling cycles. The RHCLP Air Handler has been rated and certified to operate with matching size RPCL heat pumps.

[] Designates Metric Conversions



R H C L P 2 090 C A R

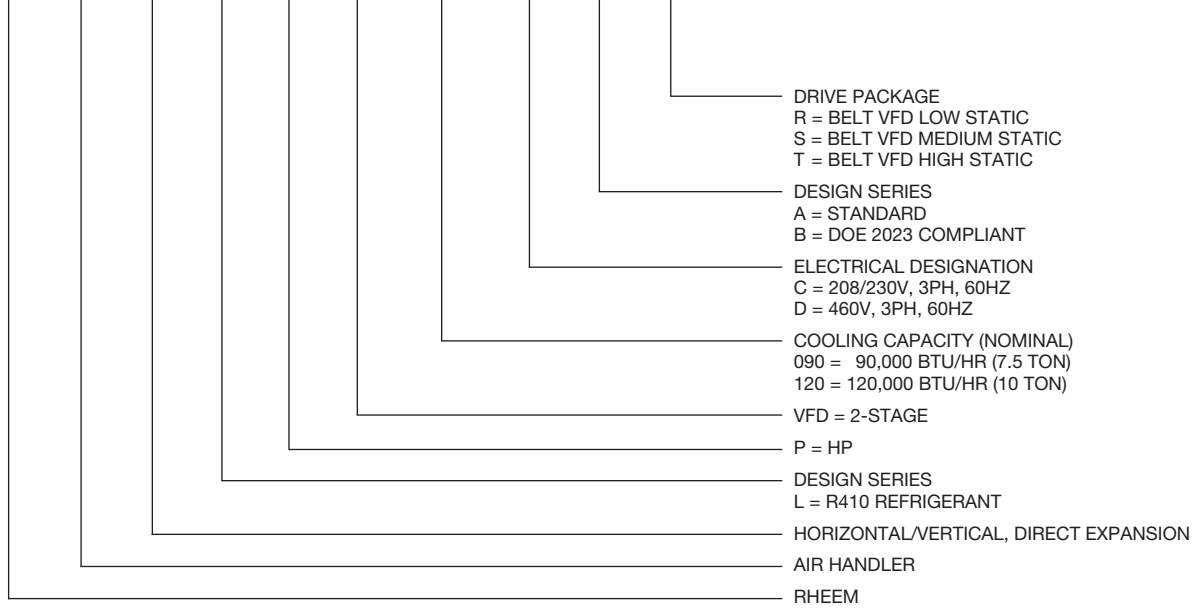

[] Designates Metric Conversions



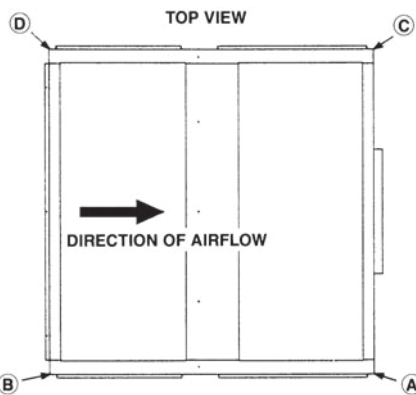
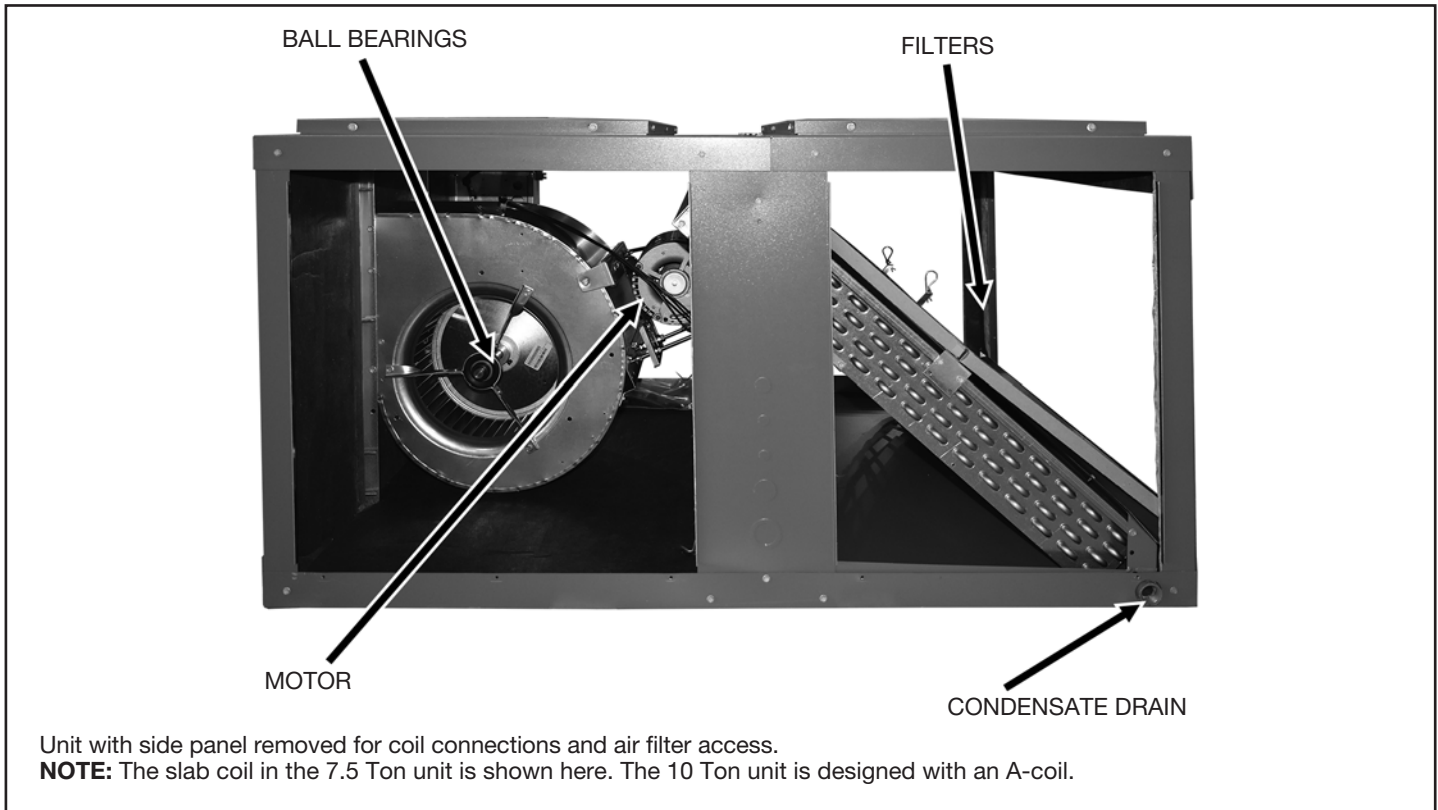

RETURN AIR OPENINGS = 47³/₈" [1203] WIDTH x 19⁷/₈" [505] HEIGHT

7.5 & 10 NOMINAL TONS [26.4 & 35.2 kW]

REFRIGERANT STUB SIZES, IN. [mm]				
MODEL	DUAL LIQ.	DUAL SUC.	SINGLE LIQ.	SINGLE SUC.
090	1/2, 1/2 [13, 13]	7/8, 7/8 [22, 22]	1/2 [13]	1 1/8 [29]
120	1/2, 1/2 [13, 13]	7/8, 7/8 [22, 22]	5/8 [16]	1 3/8 [35]

MODEL	REFRIGERANT STUB SIZES, IN. [mm]				TOTAL WEIGHT	GROSS WEIGHT
	A	B	C	D		
090	127 [57]	57 [25]	50 [22]	131 [59]	365 [165]	409 [185]
120	127 [57]	57 [25]	50 [22]	131 [59]	365 [165]	409 [185]

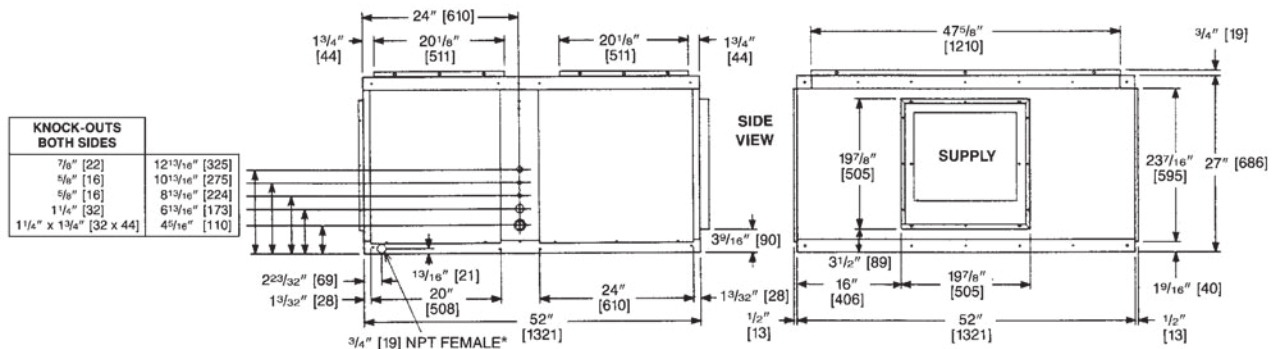

*Drain connections are provided on both sides of the drain pan. The drain can be connected to either side of the drain pan, but not both. The drain must be trapped.

[] Designates Metric Conversions



		RHCLP	
Cooling Size		090	120
Nominal size (tons)		7-1/2	10
Nominal CFM @ Rated E.S.P. (2nd Stage)		3000 @ .25"	4000 @ .30"
# of Blower Speeds		2	2
1st Stage Blower RPM %		63%	66%
MOTOR HORSEPOWER	Standard— 1750 RPM 3 phase	2 HP	2 HP
	Optional— 1750 RPM 3 phase	2 HP, 3 HP	2 HP, 3 HP
Blower Size—diameter x width		12 X 12	12 X 12
Blower Shaft Diameter		3/4	3/4
Motor Sheave	1750 RPM 3 phase	1VP50	AVL40
Belt Type & Size Std.		A-50	A-52
Coil Face Area (sq. ft.)		10.2	12.6
Coil Tube Diameter		3/8	3/8
Coil, Rows Deep-Fins Per Inch		4/15	4/15
T.X. Valve Refrigerant Control		(2) CBBIZE-5-GA	(2) CBBIZE-6-GA
Filter Size (std.)* No. Req'd		(4) 16 X 25 X 1	Field Installed
CABINET:			
Finish		Prepaint	Prepaint
Sheet Metal		Galvanized	Galvanized
Gauge: Top		18	18
Sides		16	16
Bottom		18	18
Door and Covers		20 min.	20 min.
UNIT WEIGHTS:			
Operating	R—Drive	330	447
	S—Drive	330	458
	T—Drive	341	458
Shipping	R—Drive	396	513
	S—Drive	396	535
	T—Drive	407	535



AIRFLOW PERFORMANCE RHCLP2090 — 7.5 TON [26.4kW] — 60 Hz — SIDEFLOW

Air Flow CFM [L/s]	(-) HCLP2090 Voltage 208/230 — 3 phase 60 Hz																											
	External Static Pressure—Inches of Water [kPa]																											
	0.1 [1.02]	0.2 [1.05]	0.3 [1.07]	0.4 [1.10]	0.5 [1.12]	0.6 [1.15]	0.7 [1.17]	0.8 [1.20]	0.9 [1.22]	1.0 [1.25]	1.1 [1.27]	1.2 [1.30]	1.3 [1.32]	1.4 [1.35]	1.5 [1.37]	1.6 [1.40]	1.7 [1.42]	1.8 [1.45]	1.9 [1.47]	2.0 [1.50]								
2400 [1133]	—	626 [590]	673 [644]	720 [696]	767 [745]	803 [792]	843 [854]	883 [915]	921 [976]	959 [1036]	995 [1084]	1004 [1103]	1035 [1157]	1066 [1212]	1096 [1268]	1126 [1327]	1156 [1387]	1185 [1449]	1214 [1513]	1237 [1497]								
2500 [1180]	—	641 [634]	688 [688]	734 [741]	780 [790]	815 [835]	855 [898]	893 [961]	931 [1023]	968 [1084]	1004 [1145]	1013 [1162]	1044 [1219]	1075 [1277]	1105 [1337]	1135 [1399]	1164 [1463]	1193 [1528]	1222 [1595]	1246 [1582]								
2600 [1227]	—	657 [680]	703 [736]	748 [788]	793 [838]	828 [883]	867 [948]	904 [1012]	941 [1075]	977 [1138]	1012 [1200]	1023 [1226]	1054 [1286]	1084 [1347]	1114 [1411]	1144 [1476]	1173 [1542]	1202 [1611]	1230 [1681]	1256 [1672]								
2700 [1274]	628 [671]	673 [730]	718 [786]	763 [839]	806 [890]	840 [936]	878 [1003]	915 [1068]	951 [1133]	987 [1197]	1001 [1233]	1033 [1294]	1063 [1357]	1094 [1422]	1124 [1489]	1153 [1557]	1182 [1627]	1210 [1699]	1242 [1717]	1266 [1767]								
2800 [1321]	645 [724]	690 [783]	734 [839]	778 [893]	815 [926]	853 [995]	890 [1063]	927 [1130]	962 [1196]	996 [1261]	1012 [1302]	1043 [1367]	1073 [1433]	1103 [1501]	1133 [1571]	1162 [1643]	1191 [1716]	1219 [1791]	1252 [1814]	1276 [1867]								
2900 [1368]	663 [779]	707 [839]	750 [896]	793 [951]	829 [989]	866 [1059]	903 [1128]	938 [1196]	973 [1264]	1006 [1331]	1022 [1376]	1053 [1444]	1083 [1514]	1113 [1585]	1142 [1658]	1172 [1733]	1200 [1810]	1228 [1888]	1262 [1914]	1286 [1970]								
3000 [1416]	682 [838]	725 [898]	767 [956]	806 [985]	843 [1057]	879 [1128]	915 [1199]	950 [1269]	983 [1338]	1016 [1406]	1032 [1455]	1063 [1526]	1093 [1599]	1123 [1674]	1152 [1750]	1181 [1828]	1209 [1908]	1248 [1959]	1272 [2020]	1296 [2079]								
3100 [1463]	701 [900]	743 [961]	784 [1019]	820 [1056]	857 [1130]	893 [1208]	906 [1283]	940 [1356]	973 [1429]	1005 [1500]	1023 [1551]	1054 [1627]	1084 [1705]	1114 [1784]	1143 [1865]	1172 [1948]	1201 [2033]	1229 [2119]	1268 [2177]	1293 [2310]								
3200 [1510]	720 [965]	761 [1026]	802 [1085]	836 [1133]	871 [1208]	906 [1283]	940 [1356]	973 [1429]	1005 [1500]	1023 [1551]	1054 [1627]	1084 [1705]	1114 [1784]	1143 [1865]	1172 [1948]	1201 [2033]	1229 [2119]	1268 [2177]	1293 [2310]	1316 [2310]								
3300 [1557]	740 [1033]	780 [1095]	815 [1139]	851 [1216]	886 [1292]	920 [1368]	953 [1442]	985 [1516]	1017 [1590]	1035 [1640]	1065 [1720]	1095 [1801]	1125 [1883]	1154 [1968]	1182 [2054]	1211 [2142]	1254 [2222]	1279 [2293]	1303 [2363]	1326 [2432]								
3400 [1604]	760 [1104]	799 [1167]	831 [1225]	866 [1303]	900 [1381]	934 [1458]	966 [1534]	998 [1610]	1015 [1654]	1046 [1735]	1076 [1817]	1106 [1901]	1135 [1987]	1164 [2075]	1193 [2164]	1221 [2255]	1265 [2339]	1290 [2413]	1314 [2487]	—								
3500 [1652]	781 [1179]	812 [1236]	847 [1316]	882 [1396]	915 [1475]	948 [1554]	979 [1631]	1010 [1708]	1027 [1749]	1057 [1833]	1088 [1919]	1117 [2006]	1146 [2096]	1175 [2187]	1203 [2279]	1250 [2382]	1276 [2461]	1300 [2538]	1324 [2615]	—								
4000 [1888]	868 [1677]	900 [1766]	931 [1853]	962 [1940]	991 [2026]	997 [2006]	1028 [2101]	1058 [2198]	1088 [2296]	1118 [2397]	1147 [2499]	1175 [2602]	1204 [2708]	1186 [2803]	1214 [2909]	1261 [3505]	1287 [2587]	1311 [2668]	—	—								

Airflow CFM [L/s]	AIRFLOW CORRECTION FACTORS *										COMPONENT AIRFLOW RESISTANCE														
	Sensible MBH					Power kW					Wet Coil					MERV 8 Filter					MERV 13 Filter				
	Total MBH	Sensible MBH	Power kW	Resistance Inches of Water [kPa]	Resistance Inches of Water	Total MBH	Sensible MBH	Power kW	Resistance Inches of Water [kPa]	Resistance Inches of Water	Total MBH	Sensible MBH	Power kW	Resistance Inches of Water [kPa]	Resistance Inches of Water	Total MBH	Sensible MBH	Power kW	Resistance Inches of Water [kPa]	Resistance Inches of Water	Total MBH	Sensible MBH	Power kW	Resistance Inches of Water [kPa]	Resistance Inches of Water
2400 [1133]	0.93	0.73	0.96	0.04 [0.01]	0.097	0.73	0.96	0.04 [0.01]	0.097	0.93	0.73	0.96	0.04 [0.01]	0.097	0.93	0.73	0.96	0.04 [0.01]	0.097	0.93	0.73	0.96	0.04 [0.01]	0.097	
2500 [1180]	0.93	0.74	0.96	0.05 [0.01]	0.106	0.74	0.96	0.05 [0.01]	0.106	0.93	0.74	0.96	0.05 [0.01]	0.106	0.93	0.74	0.96	0.05 [0.01]	0.106	0.93	0.74	0.96	0.05 [0.01]	0.106	
2600 [1227]	0.94	0.76	0.97	0.05 [0.01]	0.115	0.76	0.97	0.05 [0.01]	0.115	0.94	0.76	0.97	0.05 [0.01]	0.115	0.94	0.76	0.97	0.05 [0.01]	0.115	0.94	0.76	0.97	0.05 [0.01]	0.115	
2700 [1274]	0.94	0.78	0.97	0.05 [0.01]	0.124	0.78	0.97	0.05 [0.01]	0.124	0.94	0.78	0.97	0.05 [0.01]	0.124	0.94	0.78	0.97	0.05 [0.01]	0.124	0.94	0.78	0.97	0.05 [0.01]	0.124	
2800 [1321]	0.95	0.80	0.97	0.05 [0.01]	0.133	0.80	0.97	0.05 [0.01]	0.133	0.95	0.80	0.97	0.05 [0.01]	0.133	0.95	0.80	0.97	0.05 [0.01]	0.133	0.95	0.80	0.97	0.05 [0.01]	0.133	
2900 [1368]	0.95	0.81	0.97	0.06 [0.01]	0.142	0.81	0.97	0.06 [0.01]	0.142	0.95	0.81	0.97	0.06 [0.01]	0.142	0.95	0.81	0.97	0.06 [0.01]	0.142	0.95	0.81	0.97	0.06 [0.01]	0.142	
3000 [1416]	0.95	0.83	0.98	0.06 [0.01]	0.151	0.83	0.98	0.06 [0.01]	0.151	0.95	0.83	0.98	0.06 [0.01]	0.151	0.95	0.83	0.98	0.06 [0.01]	0.151	0.95	0.83	0.98	0.06 [0.01]	0.151	
3100 [1463]	0.96	0.85	0.98	0.06 [0.01]	0.160	0.85	0.98	0.06 [0.01]	0.160	0.96	0.85	0.98	0.06 [0.01]	0.160	0.96	0.85	0.98	0.06 [0.01]	0.160	0.96	0.85	0.98	0.06 [0.01]	0.160	
3200 [1510]	0.96	0.87	0.98	0.06 [0.01]	0.169	0.87	0.98	0.06 [0.01]	0.169	0.96	0.87	0.98	0.06 [0.01]	0.169	0.96	0.87	0.98	0.06 [0.01]	0.169	0.96	0.87	0.98	0.06 [0.01]	0.169	
3300 [1557]	0.97	0.88	0.99	0.07 [0.02]	0.178	0.88	0.99	0.07 [0.02]	0.178	0.97	0.88	0.99	0.07 [0.02]	0.178	0.97	0.88	0.99	0.07 [0.02]	0.178	0.97	0.88	0.99	0.07 [0.02]	0.178	
3400 [1604]	0.97	0.90	0.99	0.07 [0.02]	0.188	0.90	0.99	0.07 [0.02]	0.188	0.97	0.90	0.99	0.07 [0.02]	0.188	0.97	0.90	0.99	0.07 [0.02]	0.188	0.97	0.90	0.99	0.07 [0.02]	0.188	
3500 [1652]	0.98	0.92	0.99	0.07 [0.02]	0.197	0.92	0.99	0.07 [0.02]	0.197	0.98	0.92	0.99	0.07 [0.02]	0.197	0.98	0.92	0.99	0.07 [0.02]	0.197	0.98	0.92	0.99	0.07 [0.02]	0.197	
3600 [1699]	0.98	0.93	0.99	0.08 [0.02]	0.206	0.93	0.99	0.08 [0.02]	0.206	0.98	0.93	0.99	0.08 [0.02]	0.206	0.98	0.93	0.99	0.08 [0.02]	0.206	0.98	0.93	0.99	0.08 [0.02]	0.206	
3700 [1746]	0.99	0.95	1.00	0.08 [0.02]	0.215	0.95	1.00	0.08 [0.02]	0.215	0.99	0.95	1.00	0.08 [0.02]	0.215	0.99	0.95	1.00	0.08 [0.02]	0.215	0.99	0.95	1.00	0.08 [0.02]	0.215	
3800 [1793]	0.99	0.97	1.00	0.08 [0.02]	0.224	0.97	1.00	0.08 [0.02]	0.224	0.99	0.97	1.00	0.08 [0.02]	0.224	0.99	0.97	1.00	0.08 [0.02]	0.224	0.99	0.97	1.00	0.08 [0.02]	0.224	
3900 [1840]	1.00	0.99	1.00	0.08 [0.02]	0.233	0.99	1.00	0.08 [0.02]	0.233	1.00	0.99	1.00	0.08 [0.02]	0.233	1.00	0.99	1.00	0.08 [0.02]	0.233	1.00	0.99	1.00	0.08 [0.02]	0.233	
4000 [1888]	1.00	1.00	1.01	0.09 [0.02]	0.242	1.00	1.01	0.09 [0.02]	0.242	1.00	1.00	1.01	0.09 [0.02]	0.242	1.00	1.00	1.01	0.09 [0.02]	0.242	1.00	1.00	1.01	0.09 [0.02]	0.242	

*Multiply correction factor times gross performance data resulting sensible capacity cannot exceed total capacity.

[] Designates Metric Conversions

PERFORMANCE DATA @ AHRI STANDARD CONDITIONS

MODEL NUMBERS		80°F [26.5°C] DB 67°F [19.5°C] WB INDOOR AIR 95°F [35°C] DB OUTDOOR AIR					RATED INDOOR CFM [L/s]
OUTDOOR UNIT RPCL-	INDOOR COIL AND/OR AIR HANDLER	TOTAL CAPACITY BTU/H [kW]	NET SENSIBLE BTU/H [kW]	NET LATENT BTU/H [kW]	EER	IEER	
RPCL2090	RHCLP2090	85000 [24.9]	58200 [17.1]	26800 [7.8]	11.0	12.2	2650
RPCL2120	RHCLP2120	113000 [33.1]	83100 [24.3]	29900 [8.8]	11.2	12.2	3400

[] Designates Metric Conversions



COOLING PERFORMANCE DATA – RPCL2090CAZ + RHCLP2090CA(-)

wBE		ENTERING INDOOR AIR @ 80°F [26.7°C] dbE ①																															
		71°F [21.7°C]				67°F [19.4°C]				63°F [17.2°C]				61°F [16.1°C]				59°F [15.0°C]															
		3600 [1699]	3225 [1522]	2400 [1133]	2400 [1133]	3600 [1699]	3225 [1522]	2400 [1133]	2400 [1133]	3600 [1699]	3225 [1522]	2400 [1133]	2400 [1133]	3600 [1699]	3225 [1522]	2400 [1133]	2400 [1133]	3600 [1699]	3225 [1522]	2400 [1133]	2400 [1133]												
CFM [L/s]		0.21				0.19				0.19				0.19				0.21				0.19											
DR ①		0.12				0.12				0.12				0.12				0.12				0.12											
Total BTUH [kW]		104.3 [39.6]				97.4 [28.5]				90.5 [26.5]				80.6 [23.6]				79.4 [23.3]				74.1 [21.7]				66.4 [19.5]							
Sens BTUH [kW]		66.6 [19.5]				63.1 [18.5]				61.5 [18.0]				59.8 [17.5]				66.8 [19.6]				63.4 [18.6]				55.8 [16.4]				56.2 [16.5]			
Power		7.2				6.9				6.4				6.0				5.8				5.7				5.5				5.3			
Total BTUH [kW]		102.5 [30.0]				95.7 [28.0]				88.8 [26.0]				78.8 [23.1]				77.5 [22.7]				72.4 [21.2]				69.3 [20.3]				64.7 [19.0]			
Sens BTUH [kW]		66.0 [19.3]				62.6 [18.3]				61.1 [17.9]				59.4 [17.4]				66.3 [19.4]				62.9 [18.4]				55.4 [16.2]				54.9 [16.1]			
Power		7.4				7.2				6.6				6.2				6.0				5.8				5.7				5.6			
Total BTUH [kW]		100.3 [29.4]				93.7 [27.4]				86.8 [25.4]				76.8 [22.5]				75.3 [22.1]				70.4 [20.6]				67.1 [19.7]				62.7 [18.4]			
Sens BTUH [kW]		65.2 [19.1]				61.8 [18.1]				60.4 [17.7]				58.7 [17.2]				65.5 [19.2]				62.1 [18.2]				54.7 [16.0]				54.9 [16.1]			
Power		7.7				7.6				7.3				6.5				6.3				6.1				6.0				5.8			
Total BTUH [kW]		97.8 [28.7]				91.3 [26.8]				84.5 [24.7]				74.5 [21.8]				72.9 [21.3]				68.0 [19.9]				64.6 [18.9]				60.3 [17.7]			
Sens BTUH [kW]		64.0 [18.8]				60.7 [17.8]				59.4 [17.4]				57.7 [16.9]				64.3 [18.9]				61.0 [17.9]				53.7 [15.7]				53.8 [15.8]			
Power		8.0				7.8				7.3				6.9				6.7				6.4				6.3				6.2			
Total BTUH [kW]		95.0 [27.8]				88.7 [25.7]				81.8 [24.0]				71.9 [21.1]				70.1 [20.5]				65.4 [19.2]				61.8 [18.1]				57.7 [16.9]			
Sens BTUH [kW]		62.6 [18.3]				59.4 [17.4]				58.2 [17.1]				56.5 [16.6]				62.9 [18.4]				59.7 [17.5]				52.5 [15.4]				52.5 [15.4]			
Power		8.4				8.2				7.8				7.3				7.1				7.0				6.8				6.6			
Total BTUH [kW]		91.9 [26.9]				85.6 [25.4]				78.9 [23.1]				69.0 [20.2]				66.9 [19.6]				62.2 [18.2]				58.7 [17.2]				54.1 [15.9]			
Sens BTUH [kW]		60.9 [17.8]				57.7 [16.9]				56.8 [16.6]				55.1 [16.1]				61.2 [17.9]				58.0 [17.0]				51.1 [15.0]				51.5 [15.1]			
Power		8.9				8.8				8.5				8.2				7.8				7.5				7.4				7.1			
Total BTUH [kW]		88.5 [25.9]				82.6 [24.2]				75.7 [22.2]				65.8 [19.3]				63.5 [18.6]				59.3 [17.4]				55.3 [16.2]				51.6 [15.1]			
Sens BTUH [kW]		58.8 [17.2]				55.8 [16.4]				55.1 [16.1]				53.4 [15.6]				59.1 [17.3]				56.1 [16.4]				49.4 [14.5]				48.9 [14.3]			
Power		9.4				9.1				8.8				8.5				8.2				7.9				7.7				7.6			
Total BTUH [kW]		84.7 [24.8]				79.1 [23.2]				72.2 [21.2]				62.2 [18.2]				59.7 [17.5]				55.8 [16.3]				51.5 [15.1]				48.1 [14.1]			
Sens BTUH [kW]		56.5 [16.6]				53.6 [15.7]				53.1 [15.6]				51.4 [15.1]				56.8 [16.6]				53.9 [15.8]				47.4 [13.9]				46.7 [13.7]			
Power		9.9				9.6				9.2				8.7				8.5				8.4				8.2				8.1			
Total BTUH [kW]		80.6 [23.6]				75.3 [22.1]				68.4 [20.0]				58.4 [17.1]				55.7 [16.3]				52.0 [15.2]				47.4 [13.9]				44.3 [13.0]			
Sens BTUH [kW]		53.9 [15.8]				51.1 [15]				50.9 [14.9]				49.2 [14.4]				54.1 [15.9]				51.4 [15.1]				45.2 [13.3]				44.2 [12.9]			
Power		10.5				10.4				9.9				9.4				9.1				9.0				8.8				8.7			
Total BTUH [kW]		76.2 [22.3]				71.2 [20.9]				64.3 [18.8]				54.4 [15.9]				51.3 [15.0]				47.9 [14.0]				43.1 [12.6]				40.2 [11.8]			
Sens BTUH [kW]		50.9 [14.9]				48.3 [14.2]				48.5 [14.2]				46.8 [13.7]				51.2 [15.0]				48.6 [14.2]				43.1 [12.6]				41.4 [12.1]			
Power		11.1				11.0				10.5				10.2				9.9				9.7				9.6				9.4			
Total BTUH [kW]		71.5 [21]				66.8 [19.6]				59.9 [17.6]				50.0 [14.6]				46.6 [13.7]				43.5 [12.7]				38.4 [11.2]				35.8 [10.5]			
Sens BTUH [kW]		47.7 [14]				45.2 [13.3]				44.1 [12.9]				44.1 [12.9]				45.6 [13.4]				40.1 [11.7]				38.4 [11.2]				37.6 [11]			
Power		11.8				11.7				11.4				10.9				10.6				10.3				10.1				10.0			

OUTDOOR DRY BULB TEMPERATURE °F [°C]

DR —Depression ratio
dbE —Entering air dry bulb
wBE —Entering air wet bulb

Total —Total capacity x 1000 BTUH
Sens —Sensible capacity x 1000 BTUH
Power —kW Input

NOTES:
① When the entering air dry bulb is other than 80°F [27°C], adjust the sensible capacity from the table by adding [1.10 x CFM x (1 – DR) x (dbE – 80)].

[] Designates Metric Conversions



COOLING PERFORMANCE DATA — RPCL2120CAZ+RHCLP2120CA(-)

wDE		ENTERING INDOOR AIR @ 80°F [26.7°C] dbE ①											
		71°F [21.7°C]		67°F [19.4°C]		63°F [17.2°C]		61°F [16.1°C]		59°F [15.0°C]			
CFM [L/s]		4500 [2124]	3400 [1605]	3000 [1416]	4500 [2124]	3400 [1605]	3000 [1416]	4500 [2124]	3400 [1605]	3000 [1416]	4500 [2124]	3400 [1605]	3000 [1416]
DR ①		0.07	0.02	-0.01	0.07	0.02	-0.01	0.07	0.02	-0.01	0.07	0.02	-0.01
Total BTUH [kW]		144.4 [42.3]	136.4 [40.0]	133.5 [39.1]	135.1 [39.6]	127.5 [37.4]	124.8 [36.6]	126.1 [37.0]	119.1 [34.9]	116.6 [34.2]	118.1 [34.6]	111.5 [32.7]	109.1 [32.0]
Sens BTUH [kW]		90.0 [26.4]	78.2 [22.9]	73.9 [21.7]	106.3 [31.2]	92.4 [27.1]	87.3 [25.6]	117.5 [34.4]	102.1 [29.9]	96.5 [28.3]	118.1 [34.6]	105.0 [30.8]	99.3 [29.1]
Power		8.0	7.7	7.7	7.9	7.6	7.6	7.7	7.5	7.5	7.6	7.4	7.3
Total BTUH [kW]		141.8 [41.5]	133.9 [39.2]	131.0 [38.4]	132.4 [38.8]	125.1 [36.6]	122.4 [35.9]	123.5 [36.2]	116.6 [34.2]	114.1 [33.4]	115.4 [33.8]	109.0 [31.9]	106.7 [31.3]
Sens BTUH [kW]		88.9 [26.1]	77.3 [22.6]	73.0 [21.4]	105.2 [30.8]	91.4 [26.8]	86.4 [25.3]	116.4 [34.1]	101.1 [29.6]	95.6 [28.0]	115.4 [33.8]	104.1 [30.5]	98.4 [28.8]
Power		8.3	8.1	8.0	8.2	8.0	7.9	8.1	7.9	7.8	8.0	7.8	7.7
Total BTUH [kW]		139.0 [40.7]	131.3 [38.5]	128.5 [37.6]	129.6 [38.0]	122.4 [35.9]	119.8 [35.1]	120.7 [35.4]	114.0 [33.4]	111.6 [32.7]	112.7 [33.0]	106.4 [31.2]	104.1 [30.5]
Sens BTUH [kW]		87.7 [25.7]	76.2 [22.3]	72.0 [21.1]	104.0 [30.5]	90.4 [26.5]	85.4 [25.0]	115.2 [33.8]	100.1 [29.3]	94.6 [27.7]	112.7 [33.0]	103.0 [30.2]	97.4 [28.5]
Power		8.7	8.4	8.4	8.6	8.3	8.3	8.5	8.2	8.1	8.4	8.1	8.0
Total BTUH [kW]		136.1 [39.9]	128.5 [37.7]	125.8 [36.8]	126.7 [37.1]	119.7 [35.1]	117.1 [34.3]	117.8 [34.5]	111.3 [32.6]	108.9 [31.9]	109.8 [32.2]	103.7 [30.4]	101.4 [29.7]
Sens BTUH [kW]		86.4 [25.3]	75.1 [22.0]	70.9 [20.8]	102.7 [30.1]	89.2 [26.1]	84.3 [24.7]	113.8 [33.4]	98.9 [29.0]	93.5 [27.4]	109.8 [32.2]	101.9 [29.9]	96.3 [28.2]
Power		9.1	8.8	8.7	9.0	8.7	8.6	8.9	8.6	8.5	8.8	8.5	8.4
Total BTUH [kW]		133.1 [39.0]	125.7 [36.8]	123.0 [36.0]	123.7 [36.2]	116.8 [34.2]	114.3 [33.5]	114.8 [33.6]	108.4 [31.8]	106.1 [31.1]	106.7 [31.3]	100.8 [29.5]	98.6 [28.9]
Sens BTUH [kW]		84.9 [24.9]	73.8 [21.6]	69.7 [20.4]	101.2 [29.7]	87.9 [25.8]	83.1 [24.4]	112.4 [32.9]	97.6 [28.6]	92.3 [27.0]	106.7 [31.3]	100.6 [29.5]	95.1 [27.9]
Power		9.5	9.3	9.2	9.4	9.2	9.1	9.3	9.0	9.0	9.2	8.9	8.8
Total BTUH [kW]		129.9 [38.1]	122.7 [35.9]	120.1 [35.2]	120.5 [35.3]	113.8 [33.4]	111.4 [32.6]	111.6 [32.7]	105.4 [30.9]	103.1 [30.2]	103.6 [30.3]	97.8 [28.7]	95.7 [28.0]
Sens BTUH [kW]		83.3 [24.4]	72.3 [21.2]	68.4 [20.0]	99.6 [29.2]	86.5 [25.3]	81.8 [24.0]	110.7 [32.4]	96.2 [28.2]	90.9 [26.6]	103.6 [30.3]	97.8 [28.7]	93.7 [27.5]
Power		10.0	9.7	9.6	9.9	9.6	9.5	9.8	9.5	9.4	9.7	9.4	9.3
Total BTUH [kW]		126.6 [37.1]	119.6 [35.0]	117.0 [34.3]	117.2 [34.4]	110.7 [32.4]	108.3 [31.7]	108.3 [31.7]	102.3 [30.0]	100.1 [29.3]	100.3 [29.4]	94.7 [27.7]	92.7 [27.2]
Sens BTUH [kW]		81.5 [23.9]	70.8 [20.7]	66.9 [19.6]	97.8 [28.7]	85.0 [24.9]	80.3 [23.5]	108.3 [31.7]	94.7 [27.7]	89.5 [26.2]	100.3 [29.4]	94.7 [27.7]	92.3 [27.0]
Power		10.5	10.2	10.1	10.4	10.1	10.0	10.3	10.0	9.9	10.2	9.9	9.8
Total BTUH [kW]		123.2 [36.1]	116.3 [34.1]	113.8 [33.4]	113.8 [33.3]	107.5 [31.5]	105.2 [30.8]	104.9 [30.7]	99.0 [29.0]	96.9 [28.4]	96.8 [28.4]	91.4 [26.8]	89.5 [26.2]
Sens BTUH [kW]		79.6 [23.3]	69.1 [20.3]	65.3 [19.1]	95.9 [28.1]	83.3 [24.4]	78.7 [23.1]	104.9 [30.7]	93.0 [27.3]	87.9 [25.8]	96.8 [28.4]	91.4 [26.8]	89.5 [26.2]
Power		11.0	10.7	10.6	10.9	10.6	10.5	10.8	10.5	10.4	10.7	10.4	10.3
Total BTUH [kW]		119.6 [35.0]	112.9 [33.1]	110.5 [32.4]	110.2 [32.3]	104.1 [30.5]	101.9 [29.9]	101.3 [29.7]	95.7 [28.0]	93.6 [27.4]	93.2 [27.3]	88.1 [25.8]	86.2 [25.3]
Sens BTUH [kW]		77.5 [22.7]	67.4 [19.7]	63.7 [18.7]	93.8 [27.5]	81.5 [23.9]	77.0 [22.6]	101.3 [29.7]	91.2 [26.7]	86.2 [25.3]	93.2 [27.3]	88.1 [25.8]	86.2 [25.3]
Power		11.6	11.2	11.1	11.4	11.1	11.0	11.3	11.0	10.9	11.2	10.9	10.8
Total BTUH [kW]		115.9 [34.0]	109.4 [32.1]	107.1 [31.4]	106.5 [31.2]	100.6 [29.5]	98.4 [28.8]	97.6 [28.6]	92.2 [27.0]	90.2 [26.4]	89.5 [26.2]	84.6 [24.8]	82.8 [24.3]
Sens BTUH [kW]		75.3 [22.1]	65.4 [19.2]	61.9 [18.1]	91.6 [26.9]	79.6 [23.3]	75.2 [22.0]	97.6 [28.6]	89.3 [26.2]	84.4 [24.7]	89.5 [26.2]	84.6 [24.8]	82.8 [24.3]
Power		12.1	11.8	11.7	12.0	11.7	11.6	11.9	11.6	11.5	11.8	11.5	11.4
Total BTUH [kW]		112.1 [32.8]	105.8 [31.0]	103.6 [30.3]	102.7 [30.1]	97.0 [28.4]	94.9 [27.8]	93.8 [27.5]	88.6 [25.9]	86.7 [25.4]	85.7 [25.1]	81.0 [23.7]	79.2 [23.2]
Sens BTUH [kW]		73.0 [21.4]	63.4 [18.6]	59.9 [17.6]	89.3 [26.2]	77.6 [22.7]	73.3 [21.5]	93.8 [27.5]	87.3 [25.6]	82.5 [24.2]	85.7 [25.1]	81.0 [23.7]	79.2 [23.2]
Power		12.7	12.4	12.3	12.6	12.3	12.2	12.5	12.2	12.0	12.4	12.1	11.9

NOTES:

 ① When the entering air dry bulb is other than 80°F [27°C], adjust the sensible capacity from the table by adding $[1.10 \times \text{CFM} \times (1 - \text{DR}) \times (\text{dbE} - 80)]$.

 Total — Total capacity x 1000 BTUH
 Sens — Sensible capacity x 1000 BTUH
 Power — kW input

[] Designates Metric Conversions

 DR — Depression ratio
 dbE — Entering air dry bulb
 wDE — Entering air wet bulb



ELECTRICAL DATA – WITHOUT ELECTRIC HEAT

MODEL NUMBER	DRIVE PACKAGE	AIR HANDLER MOTOR					MINIMUM CIRCUIT AMPACITY	RECOMMENDED MINIMUM COPPER WIRE SIZE/ MAX. RUN IN FEET	MAXIMUM OVERCURRENT PROTECTION AMPS
		HP	VOLTS	PHASE	RATING PLATE AMPS	MOTOR LRA			
RHCLP2090C	R, S	2	208/230	3	6.2	47	15	#14 / 165	15
RHCLP2090D	R, S	2	460	3	3	24	15	#14 / 275	15
RHCLP2090C	T	3	208/230	3	9.2	74.5	15	#14 / 135	15
RHCLP2090D	T	3	460	3	4.6	38.1	15	#14 / 230	15
RHCLP2120C	R	2	208/230	3	6.2	47	15	#14 / 165	15
RHCLP2120D	R	2	460	3	3	24	15	#14 / 275	15
RHCLP2120C	S, T	3	208/230	3	9.2	74.5	15	#14 / 135	15
RHCLP2120D	S, T	3	460	3	4.6	38.1	15	#14 / 230	15

ELECTRICAL DATA – WITH ELECTRIC HEAT

MODEL NUMBER	HEATER KIT				HEATING CAPACITY		MIN. CIRCUIT AMPACITY	MAX FUSE OR HACR BREAKER SIZE
	MODEL	VOLTAGE	kW	AMPS	kW	MBH		
RHCLP2090C	RXHE-DE020CA	208/240	20	43.1/48.9	15.6/20.2	53.2/68.9	67/73	70/80
RHCLP2090C	RXHE-DE030CA	208/240	30	60.8/70.2	11.0/29.6	75.1/101	89/100	90/100
RHCLP2090D	RXHE-DE020DA	480	20	24.7	20.2	68.9	37	40
RHCLP2090D	RXHE-DE030DA	480	30	35	29.7	101.3	50	50
RHCLP2120C	RXHE-DE020CA	208/240	20	43.1/48.9	15.6/20.2	53.2/68.9	67/73	70/80
RHCLP2120C	RXHE-DE030CA	208/240	30	60.8/70.2	11.0/29.6	75.1/101	89/100	90/100
RHCLP2120D	RXHE-DE020DA	480	20	24.7	20.2	68.9	37	40
RHCLP2120D	RXHE-DE030DA	480	30	35	29.7	101.3	50	50



TYPICAL PIPING RECOMMENDATIONS

INDOOR COIL ABOVE OUTDOOR UNIT

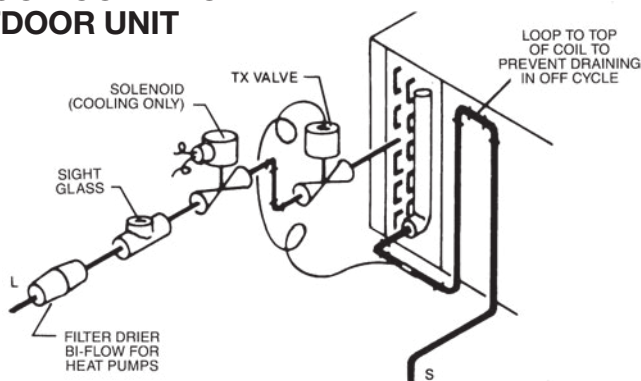

INDOOR COIL BELOW OUTDOOR UNIT

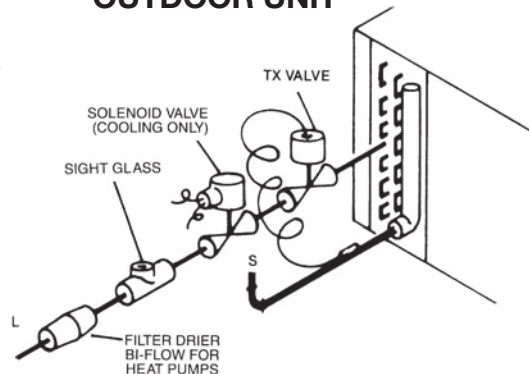

NOTE: PIPING ACCESSORIES SHOWN SHOULD BE MOUNTED AS CLOSE TO AIR HANDLING UNIT AS POSSIBLE.

REFRIGERANT PIPING

1. Size liquid line for no more than 50 PSIG pressure drop.
2. Size suction lines for no more than 2°F loss, which corresponds to approximately 5 PSIG pressure drop.
3. When evaporator is installed below condensing unit, do not exceed the recommended suction line O.D. This will insure adequate velocities for proper oil return.
4. Install strainer-drier and sight glass in liquid line.
5. Pitch all horizontal suction lines downward in the direction of flow.
6. When making up refrigerant piping, take every precaution to prevent dirt and moisture from entering the piping.
7. Locate the condensing unit and evaporator(s) as close together as possible to minimize piping runs.
8. A liquid line solenoid installed just ahead of the expansion valve is recommended.
9. See tables below for general refrigerant line sizing and equivalent length of valves and fittings.
10. Refer to the vapor and liquid line selection procedure and charts in the outdoor unit installation manual or literature for more specific refrigerant line sizing information. When dual outdoor units are matched with the air-handler using dual circuits, size the refrigerant lines for each system independently.

RECOMMENDED VAPOR AND LIQUID LINE SIZES FOR VARIOUS LENGTHS OF RUN				
LINEAR LENGTH (FT.) [m]	LIQUID LINE O.D. SIZES (IN.) [mm]		VAPOR LINE O.D. SIZES (IN.) [mm]	
	090	120	090	120
0-40 [0-12.19]	1/2 [12.7]	5/8 [15.88]	1 1/8 [28.58]	1 3/8 [34.93]
41-90 [12.5-27.43]	1/2 [12.7]	5/8 [15.88]	1 3/8 [34.93]*	1 3/8 [34.93]*

*NOTE: With the outdoor unit located below the indoor air handler, all vertical vapor lines must not exceed 1 1/8" [28.58 mm] O.D.

[] Designates Metric Conversions

CONDENSATE DRAIN PIPING

- Consult local codes or ordinances for specific requirements regarding condensate drain.
- Condensate drain is open to atmosphere and must be trapped. Trap must be at least 3 inches [76 mm] deep and made of flexible material or fabricated to prevent freeze-up.
- Pitch the drain line at least 1/4 inch [6 mm] per foot away from the drain pan.
- Do not reduce the drain line size from the connection size provided on the unit.
- Do not connect the drain line to a closed sewer line.

TYPICAL PIPING RECOMMENDATIONS

All models are provided with dual circuit coil manifolds that can be configured for dual condensing unit applications. The coil is circuited to provide full face coil operation for each system. Knock-outs are provided on both sides of the unit to allow the refrigerant tubing to enter from either side. Remove the rubber grommets from the parts bag and install them in the appropriate holes prior to running the line set tubing into the cabinet to seal around and protect the tubing. Copper fittings are provided in the parts bag to allow the two refrigerant circuits to be tied together for single condensing unit applications. The fittings may be installed to allow the tubing to enter the unit from either side as shown in Figure 5.

EQUIVALENT LENGTH (FT.) [m] OF STRAIGHT TYPE "L" TUBING FOR NON-FERROUS VALVES AND FITTINGS (BRAZED)				
TUBE SIZE INCHES [mm] O.D.	ANGLE VALVE	SHORT RADIUS ELL	LONG RADIUS ELL	TEE LINE FLOW
1/2 [12.7]	24 [7.32]	4.7 [1.43]	3.2 [0.98]	1.7 [0.52]
5/8 [15.88]	25 [7.62]	5.7 [1.74]	3.9 [1.19]	2.3 [0.70]
3/4 [19.05]	25 [7.62]	6.5 [1.98]	4.5 [1.37]	2.9 [0.88]
7/8 [22.23]	28 [8.53]	7.8 [2.38]	5.3 [1.62]	3.7 [1.13]
1 1/8 [28.58]	29 [8.84]	2.7 [0.82]	1.9 [0.58]	5.2 [1.59]
1 3/8 [34.93]	33 [10.06]	3.2 [0.98]	2.2 [0.67]	6.9 [2.10]

FIELD INSTALLED ACCESSORIES & KITS

ACCESSORY DESCRIPTION	MODEL NUMBER	SIZE USED ON	NET WEIGHT (LBS) [kg]
Hot Water Coil	RXHC-C74W	090, 120	200 [91]
Steam Coil	RXHC-C714S	090, 120	200 [91]
Filter Frame Coil	RXHF-B74A	090, 120	90 [41]
Inlet Grille Kit	RXHG-C74A	090, 120	9 [4]
Discharge Grille Kit	RXHG-C74B	090, 120	15 [7]
Discharge Plenum Kit	RXHL-C74B	090, 120	38 [17]
Mixing Box	RXHM-BC74H	090, 120	120 [54]
Auxiliary Heater Kit	RXHE-DE020*A	090, 120	75 [34]
	RXHE-DE030*A	090, 120	75 [34]
MERV 8	RXMF-M08A11625	090, 120	2 [1]
MERV 13	RXMF-M13A11625	090, 120	2 [1]
External Filter Rack	RXHF-F1	090, 120	18 [8]

NOTE: *Designates "C", "D" or "Y" Voltage

RXHM MIXING BOX



RXHE ELECTRIC HEATER KIT

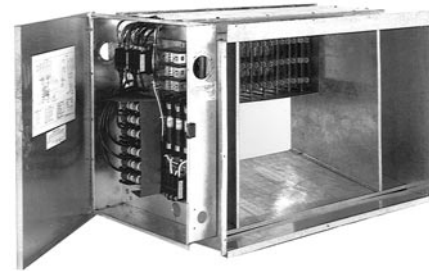

HOT WATER OR STEAM COILS

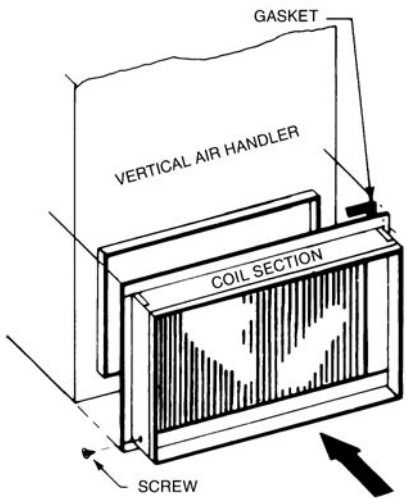

(090, 120) RXHC-C74W
RXHC-C74S

(090, 120) RXHC-C74W
RXHC-C74S

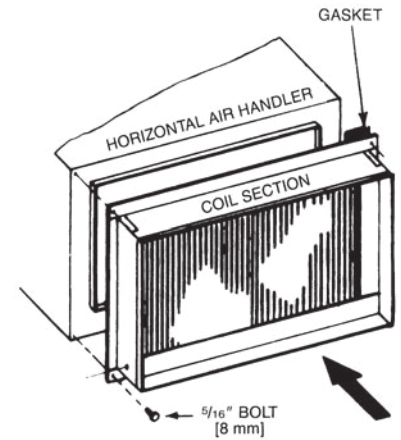

ELECTRIC RESISTANCE HEATER KITS

Optional electrical heater kit shown installed in horizontal position and connected directly to the air handler. The heater kit may also be installed with the air handler set in the vertical position. In either position the heater kit control compartment must be on the left side facing the air discharge opening.

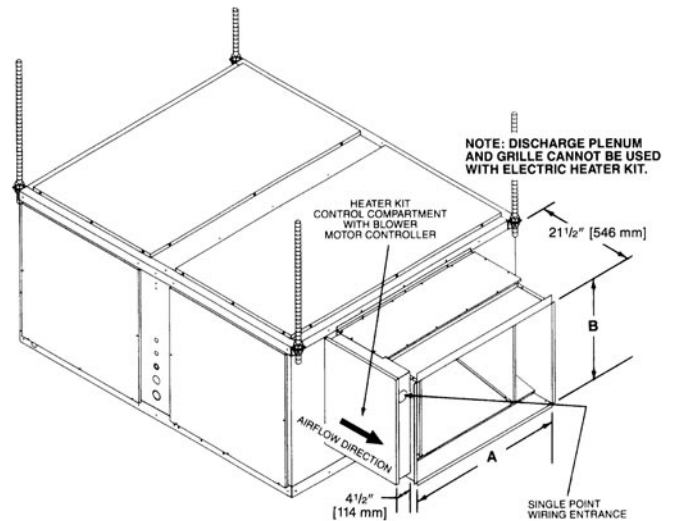

AUXILIARY HEATER KIT

MODEL NO.	IN. [mm]	
	A	B
RXHE-DE****A	20 [508]	20 [508]

[] Designates Metric Conversions

FIELD INSTALLED ACCESSORIES (CON'T.)

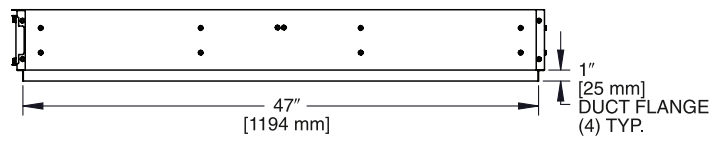
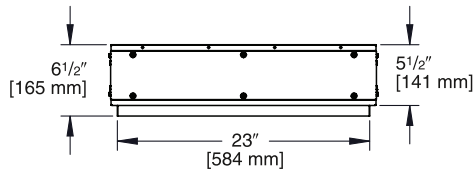
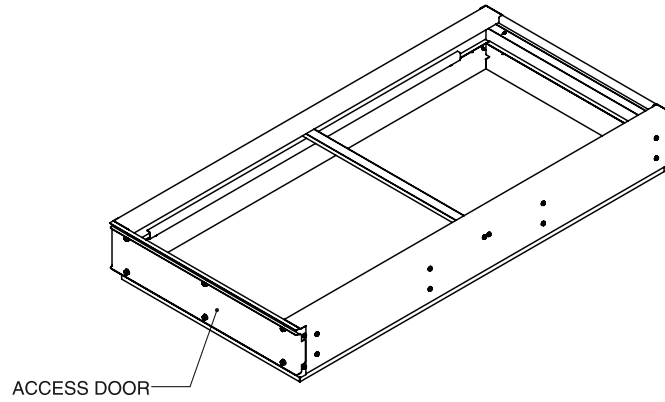
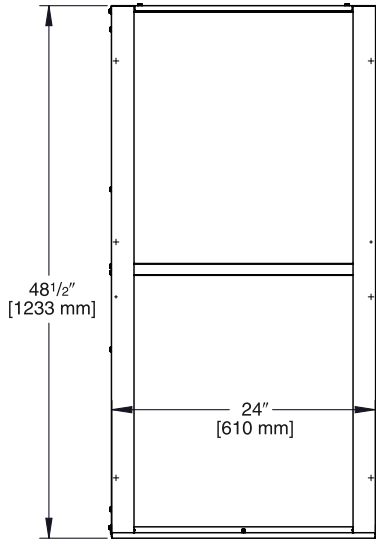

Illustration
ST-A1323-01

[] Designates Metric Conversions

GUIDE SPECIFICATIONS

Furnish and install as shown on the drawing for both horizontal and vertical applications. The entire assembly shall be UL and cUL listed with the cooling (and heat pump heating) capacity A.R.I. Certified.

DRIVE PACKAGE—A complete drive package shall be factory or field installed. Package shall consist of a 3450 RPM dual volt-age, single phase open drip proof motor or a 3 phase 1750 RPM open drip proof internally protected motor, not requiring an external starter. Variable pitch motor sheave, fixed pitch fan sheave, and belt.

COILS—Coils shall be fabricated of 3/8" [10 mm] O.D. seamless copper tubing expanded into aluminum fins. All coils shall be submitted to an air pressure test of up to 550 PSIG [2068 kPa] under water after fabrication and dehydrated prior to assembly in unit. Units shall be shipped with a nitrogen holding charge. Airflow shall be draw through design providing uniform air distribution across the coil surface. The RHCLP090 is designed with a slab coil. The RHCLP120 is designed with an A-coil.

BLOWER, BEARINGS AND SHAFT—Fans shall be a double width, double inlet, forward curve, centrifugal type, statically and dynamically balanced, and constructed of galvanized steel. They shall be mounted on 3/4" [19 mm] = 7.5 ton [26 kW] diameter solid shafts made of high carbon steel, centerless ground and polished, supported by resilient mounted sealed bearings.

DRAIN PAN—The drain pan shall be manufactured of zinc coated steel. The pan shall have internally threaded pipe size drain connections and shall be designed to accept condensate in either horizontal or vertical type applications on either side of unit.

FILTERS—Filter mounting hardware shall be designed to accept up to 2" [51 mm] filters for field replacement. One inch [25 mm] throw away filters shall be furnished with the unit. MERV 8 and MERV 13 filters are available as an accessory.

CABINET—Cabinets shall be manufactured of galvanized steel subjected to multi-stage cleaning and finished with powder coat paint. Units shall have removable service access panels on each side and top.

INSULATION—Cabinets shall be insulated with 1/2" [13 mm] by 1-1/2 pound [.68 kg] density fiberglass insulation coated with neo-prene and bonded to the cabinet surface with a U.L. approved adhesive. Insulation shall have fire retarding characteristics in accordance with smoke developed rating not to exceed 50 and flame spread rating of 25 per Underwriters Laboratories testing procedures.

FACTORY TESTING—In addition to the pre-assembly testing mentioned above, each coil shall be leak tested after assembly into the unit. While under pressure, the coil shall be leak tested using an Electronic Leak Detector.

ELECTRIC HEATERS—UL and cUL listed electric heater kits shall be available in a wide range of capacities. All kits shall offer two stages of capacity, blower motor controller and single point connection. Heater kits shall be available for installation directly on the supply fan discharge for either horizontal or vertical application.

[] Designates Metric Conversions



The new degree of comfort.™

GENERAL TERMS OF LIMITED WARRANTY*

Rheem will furnish a replacement for any part of this product which fails in normal use and services within the applicable periods stated below, in accordance with the terms of the limited warranty.

*For Complete Details of the Limited Warranty, Including Applicable Terms and Conditions, See Your Local Installer or Contact the Manufacturer for a Copy.

Any PartOne (1) Year

Before proceeding with installation, refer to installation instructions packaged with each model, as well as complying with all Federal, State, Provincial, and Local codes, regulations, and practices.

© 2024 Rheem Manufacturing Company. Rheem trademarks owned by Rheem Manufacturing Company.

In keeping with its policy of continuous progress and product improvement, Rheem reserves the right to make changes without notice.

5600 Old Greenwood Road
Fort Smith, Arkansas 72908 • www.rheem.com

125 Edgeware Road, Unit 1
Brampton, Ontario • L6Y 0P5



INTEGRATED HOME COMFORT