

ASL Slim-Temp Unit Coolers

Air and Electric Defrost Models



Installation and Operations Manual

ASL Slim-Temp Unit Coolers

Inspection

When the equipment is received, the number of crates and cartons should be checked against the bill of lading for possible shortages. Any damage should be noted immediately and a report given to the carrier and the HTP factory. It is the customer's responsibility to file all freight claims with the carrier. Unit name plates should be checked to make sure voltages are in agreement with the power available.

Installation

Installation and maintenance to be preformed by qualified personnel who are familiar with the local codes and regulations and who are experienced with this type of equipment.

CAUTION: Avoid contact with sharp edges and coil surfaces. They are potential hazards.

The unit must be installed level for proper drainage. This rear discharge unit, draws air up through the fan blades and discharges out the coils length. Proper clearances should be maintained for proper air flow and service access to the unit as follows: 6" minimum between each coil and wall. The unit should be supported on #10 screws or 1/4" diameter bolts. To meet NSF requirements, the unit must be positioned flush with the ceiling and all gaps properly caulked.

Refrigerant Connections

Refrigerant connections should be installed in accordance with all applicable codes and using good refrigeration practices. A suction line trap must be installed prior to any risers in the suction line. Horizontal suction lines should be sloped to provide proper oil return to the compressor. Suction lines should be properly insulated to prevent sweating and higher return gas temperatures.

Drain Line

The drain line should be sharply pitched and should exit the enclosure as quickly as possible. The drain line should be insulated and sealed where it passes through the wall and trapped outside the refrigerated area and protected from freezing. In room temperatures below 34° F, the drain line should be heated and insulated.

Wiring

Wiring should be done in accordance with all national and local codes. Electric defrost units are supplied with a temperature sensing defrost termination switch which will terminate the defrost at a preset temperature. A fan delay switch is also provided to allow the coil to cool down prior to the fans turning on after defrost. The time clock should be adjusted to have a maximum of a 30 minute override to prevent overheating and steaming of the coils. The number of defrosts per day will be determined by the usage of the box and the frost buildup on the coils. On hot gas units, refer to the system manufacturer's recommendations.

Expansion Valve

Expansion valves are to be installed in accordance with the specific manufacturer's recommendations. Units that require an external equalized expansion valve must have that line connected. Proper location of the bulb is extremely important to the performance of the coil. Good thermal contact to the suction line is also essential. On solder type valves, a wet cloth wrapped around the valve during installation will protect it from overheating and damage. Superheat settings should be checked after the system has balanced out at the desired room temperature. On systems sized for a 10° to 12°FTD, the valve should be adjusted to maintain 5° to 6°F superheat. Higher TD applications will allow a higher superheat setting. On multiple evaporator systems, the piping should be arranged such that the flow from any valve cannot affect the bulb of an other.

General Maintenance

General maintenance involves an occasional cleaning of dirt accumulation on the fan, fan guard or coil. The motors are life lubricated and do not require any regular maintenance.

Figure 1

Wiring Diagram - Air Defrost

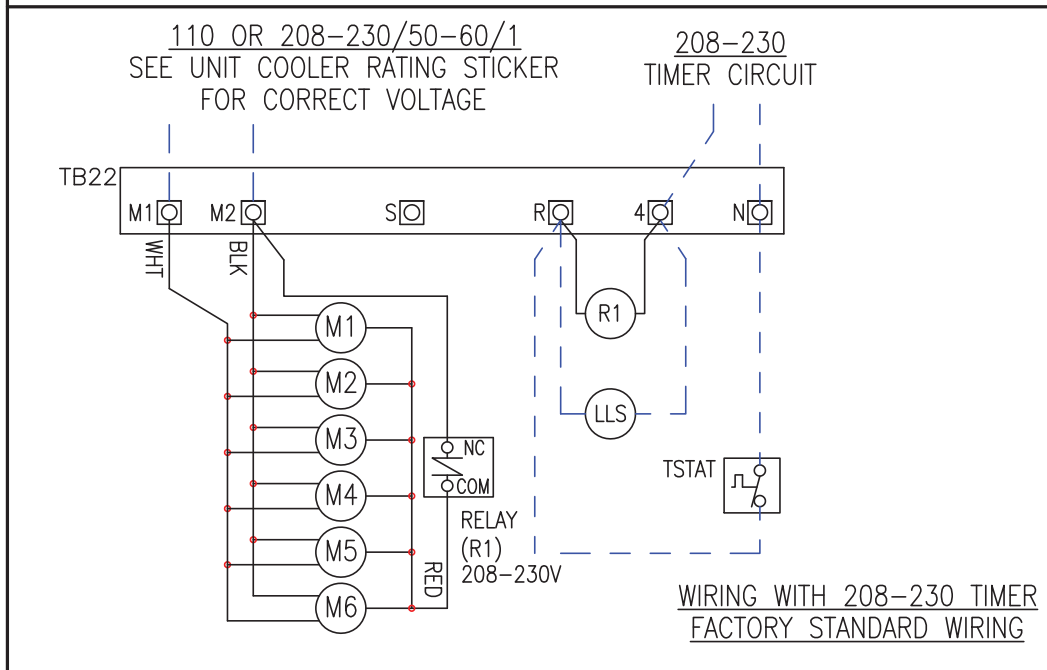
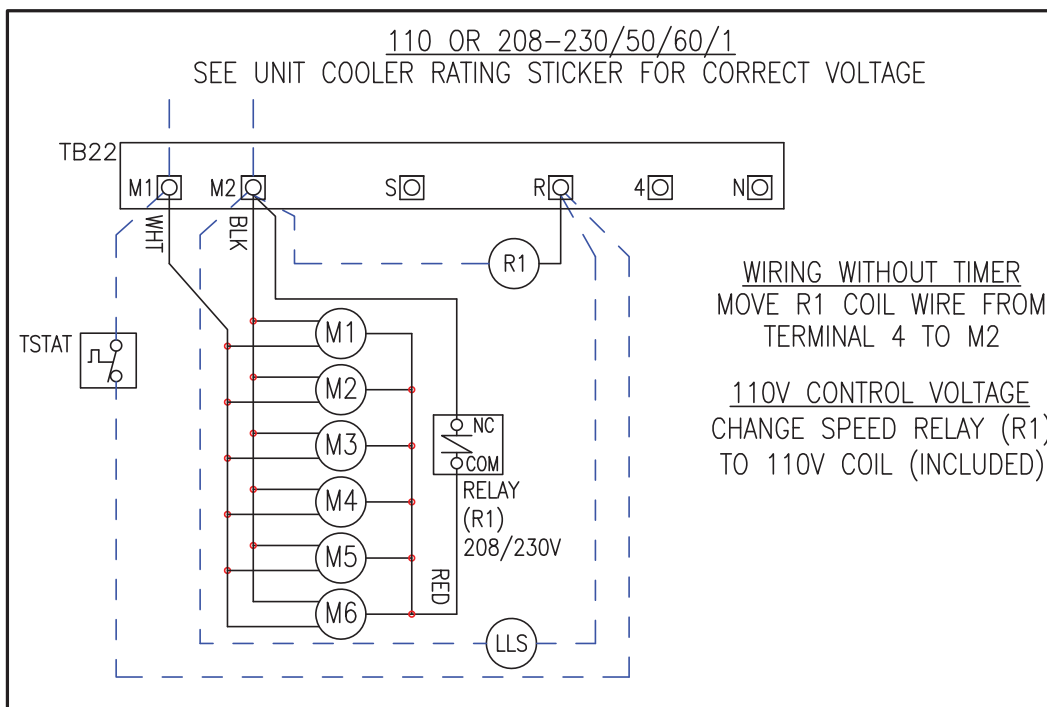

NOTES:

1. USE COPPER CONDUCTORS ONLY
2. UNIT MUST BE GROUNDED
3. 4, 3, N, & X TERMINALS FOR PARAGON TYPE 8145 TIMER
4. FOR MOTOR AND HEATER AMPS SEE RATING STICKER ON OUTSIDE OF UNIT.
5. SPEED RELAY (R1) COIL AND LLS COIL VOLTAGE MUST MATCH

LEGEND:

- TB - TERMINAL BOARD
- HTR - HEATER
- HS - HEATER SAFETY
- DTFD - DEFROST TERMINATION & FAN DELAY
- M1 - MOTOR #1, ETC.
- TSTAT - THERMOSTAT
- LLS - LIQUID LINE SOLENOID
- R1 - RELAY

FACTORY WIRING ———
FIELD WIRING - - - - -

ASL Slim-Temp Unit Coolers

Figure 2

Wiring Diagram - Electric Defrost

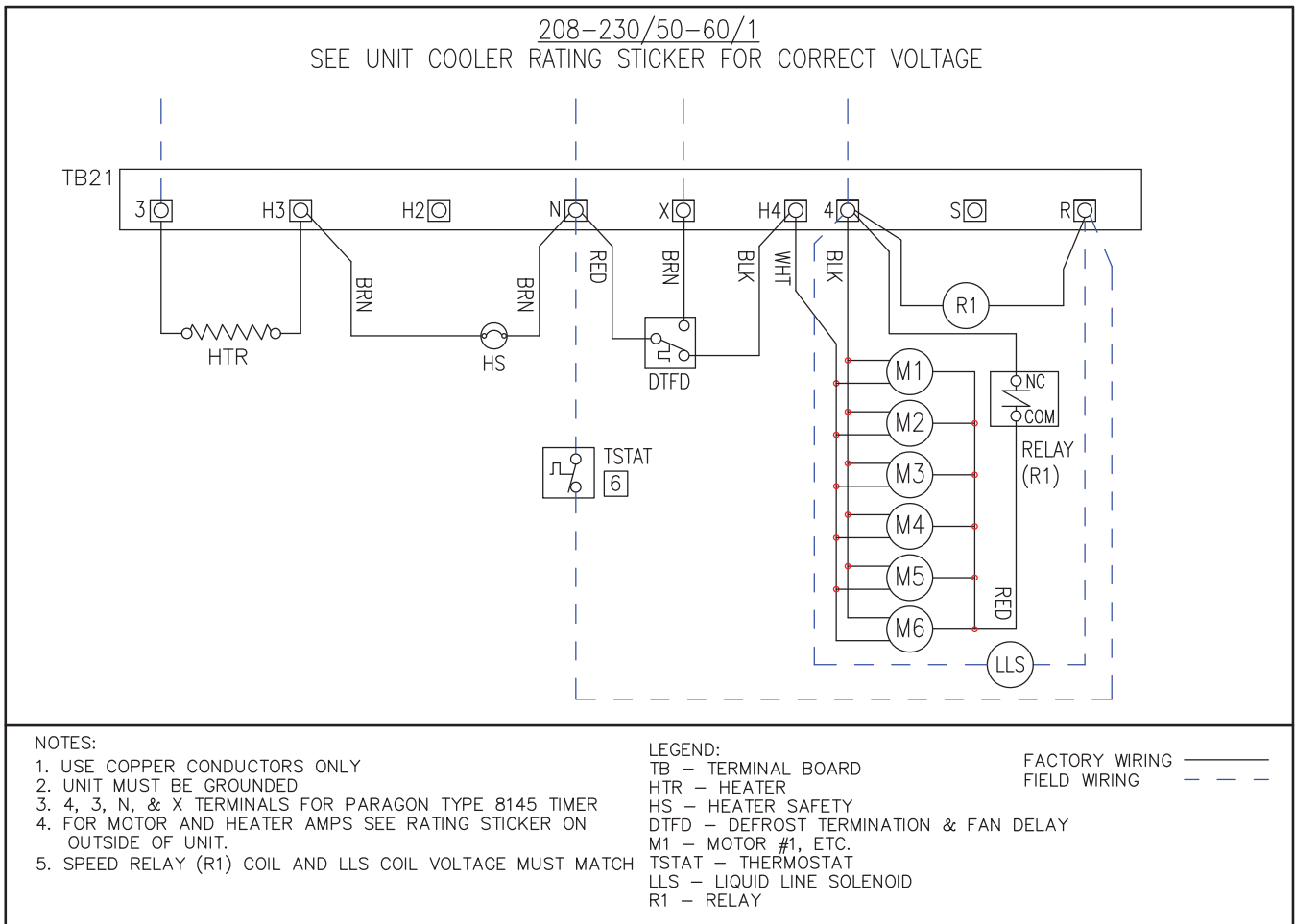

Installation and Operations Manual

Figure 3

Physical Dimensions

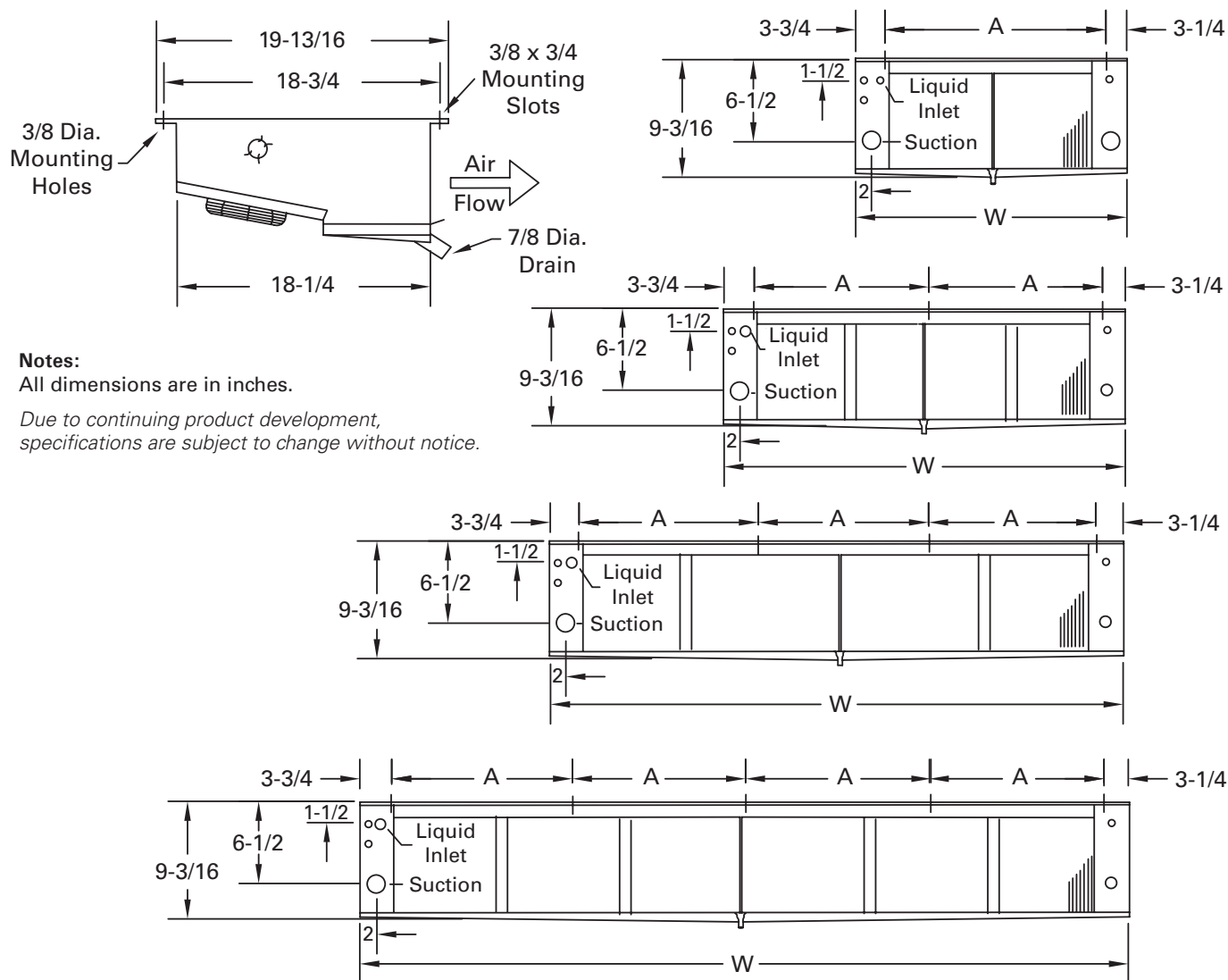

ASL Slim-Temp Unit Coolers

ASLA/ASLE Slim-Temp Unit Coolers Replacement Parts

Part Number	Description
All ASLA/ASLE Models	
08219328	CNTL,DTFD,SPDT,O35/C55+O55/C35
103079003	CONTROL, HTR SAFETY
082161211	MOTOR,ECM,16W,115/230V, 2SPEED
08533917	FAN BLADE,1028CCW-1/4
08533916	FAN BLADE,1028CCW-1/4 (REV)
201006002	FAN GUARD, WIRE, EPOXY COATED, 10"
201006002	FAN GUARD, WIRE, EPOXY COATED, 10"
ASLE Electric Defrost Models	
ASL25-46E	
205221013	DEFROST HEATERS, CORE, 1300 WATTS, 39" LENGTH, 230 V.
20248901	DRAIN PAN, 46" LENGTH
ASL35-70E	
205221016	DEFROST HEATERS, CORE, 1850 WATTS, 62" LENGTH, 230 V.
20248902	DRAIN PAN, 69" LENGTH
ASL45-94E	
205221007	DEFROST HEATERS, CORE, 1250 WATTS, 42" LENGTH, 230 V. (2 REQ'D)
20248903	DRAIN PAN, 92" LENGTH
ASL55-117E	
205221010	DEFROST HEATERS, CORE, 1600 WATTS, 54" LENGTH, 230 V. (2 REQ'D)
20248904	DRAIN PAN, 115" LENGTH

Part Number	Description
ASLE 25-46	
205221013	DEFROST HEATERS, CORE, 1300 WATTS, 39" LENGTH, 230 V.
202489001	DRAIN PAN
ASLE 25-58	
200172026	DEFROST HEATERS, CORE, 1970 WATTS, 48" LENGTH, 230 V.
202489001	DRAIN PAN
ASLE 35-70	
205221016	DEFROST HEATERS, CORE, 1850 WATTS, 62" LENGTH, 230 V.
202489002	DRAIN PAN
ASLE 45-94	
205221007	DEFROST HEATERS, CORE, 1250 WATTS, 42" LENGTH, 230 V. (2 REQ'D)
202489003	DRAIN PAN
ASLE55-117	
205221010	DEFROST HEATERS, CORE, 1600 WATTS, 54" LENGTH, 230 V. (2 REQ'D)
202489004	DRAIN PAN

TO INQUIRE OR ORDER REPLACEMENT PARTS

Email: parts@htpg.com
 Telephone: 1-855-HTPARTS
 (1-855-487-2787)
 Fax: (256) 259-7478

1. Provide the complete Model Number and Serial Number of the unit.
2. Provide a detailed description of the part with any model, diameter, HP, or other markings.
3. State the quantity you are ordering.
4. Advise special shipping methods, routes, procedures, or instructions with ship to address.
5. Provide complete and accurate data to insure prompt and accurate delivery.

This page intentionally left blank.

ASL Slim-Temp Unit Coolers

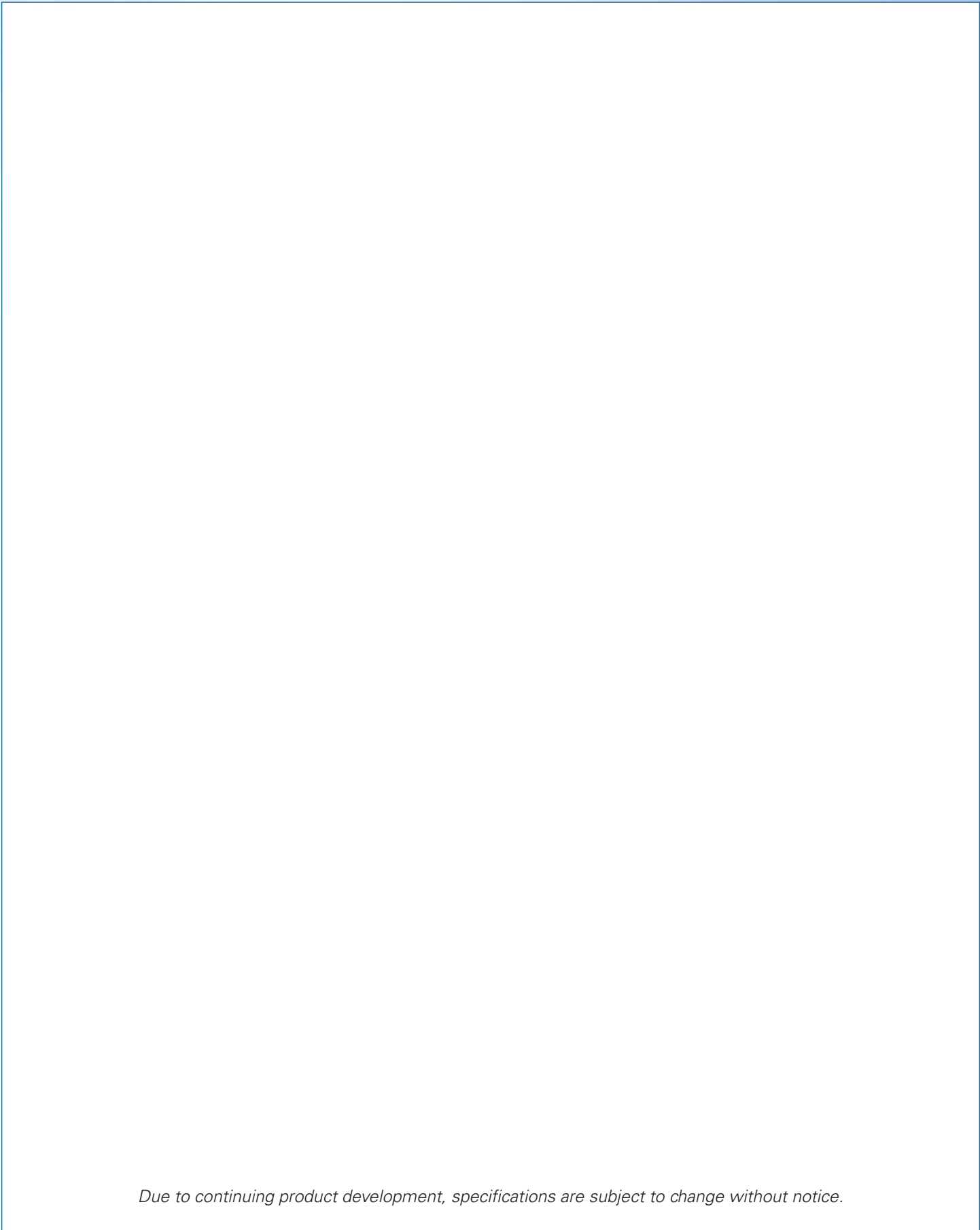

Due to continuing product development, specifications are subject to change without notice.