



Endeavor[®] Line *Prestige*[®] Series Heat Pumps



This product meets a stringent set of our internally defined sustainability standards



RP18AZ

Cooling Efficiencies up to: 20.0 SEER2 / 12.5 EER2

Heating Efficiency: 8.5 HSPF2

Nominal Sizes: 2 to 5 Tons [7.0 to 17.6 kW]

Cooling Capacities 22.8 to 55.0 kBTU [6.7 to 16.1 kW]

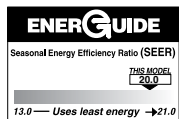

**Proper sizing and installation of equipment is critical to achieve optimal performance. Split system air conditioners and heat pumps must be matched with appropriate coil components to meet ENERGY STAR[®]. Ask your Contractor for details or visit www.energystar.gov.*

Table of Contents

Features and Benefits	3
Model Number Identification	4
General Data/Electrical Data	5
Accessories	6
Unit Dimensions	7
Clearances	8
Refrigerant Line Size Information	9-10
Capacity Ranges	11-14
Performance Data	15
Smart Home Systems	16
Limited Warranty	20

Features and Benefits

- **EcoNet® Enabled:** Automatic system configuration and optimization
- **PlusOne® Diagnostics & Bluetooth®¹ Connectivity:** With the Rheem Contractor & EcoNet® Apps, built-in technology makes advanced set-up, monitoring, troubleshooting, and repairing the product easier than ever before
- **Variable Speed Scroll Compressor & Inverter Drive:**
 - Features variable speed operation from 40 to 100% capacity with the EcoNet® Smart Thermostat
 - Offers overdrive capability up to 115% to maintain performance in extreme conditions
 - Provides precise temperature control, advanced humidity control and greater efficiency
- **Brushless DC Condenser Motors (BLDC):** Enhances reliability and allows for easier serviceability
- **Swept Wing Fan Technology:** Features quieter operation and improved unit acoustics

¹The Bluetooth® word mark and logos are registered trademarks owned by Bluetooth SIG, Inc. and any use of such marks by Rheem® is under license. Other trademarks and trade names are those of their respective owners.

Heat Pumps

<u>R</u>	<u>P</u>	<u>18</u>	<u>A</u>	<u>Z</u>	<u>24</u>	<u>A</u>	<u>J</u>	<u>V</u>	<u>C</u>	<u>A</u>
Brand	Product Category	SEER2	Region	Refrigerant	Capacity	Major Series	Voltage	Type	Controls	Minor Series
R - Rheem	P - Heat Pump	18 - 18 SEER2	A - All Regions	Z - R-410A	24 - 24,000 [7.03 kW] 36 - 36,000 [10.55 kW] 48 - 48,000 [14.07 kW] 60 - 60,000 [17.58 kW]	A - 1st Design	J - 208/230/1/60	V - Fully Variable	C - Communicating	A - 1st Design

[] Designates Metric Conversions

AVAILABLE MODELS	DESCRIPTION
RP18AZ24AJVCA	Endeavor® Line <i>Prestige</i> ® Series 2 ton EcoNet® Enabled Inverter Driven Variable Speed iM Heat Pump - 208/230/1/60
RP18AZ36AJVCA	Endeavor® Line <i>Prestige</i> ® Series 3 ton EcoNet® Enabled Inverter Driven Variable Speed iM Heat Pump - 208/230/1/60
RP18AZ48AJVCA	Endeavor® Line <i>Prestige</i> ® Series 4 ton EcoNet® Enabled Inverter Driven Variable Speed iM Heat Pump - 208/230/1/60
RP18AZ60AJVCA	Endeavor® Line <i>Prestige</i> ® Series 5 ton EcoNet® Enabled Inverter Driven Variable Speed iM Heat Pump - 208/230/1/60

STANDARD EQUIPMENT
R-410A Refrigerant
EcoNet® Enabled
Variable Speed Compressor
Compressor Sound Blanket
Variable speed outdoor fan motor
Swept wing fan blade
Field Installed Filter Drier
Front Seating Service Valves
Internal Pressure Relief Valve
Internal Thermal Overload
Low Ambient capability
3–4–5 Expanded Valve Space
Composite Basepan
1" Screw Control Box Access
Quick release louver panel design
No fasteners to remove along bottom
Optimized Venturi Airflow
Single row condenser coil
Powder coated paint
Rust resistant screws
QR code
External gauge ports
Service trays

General Data				
MODEL NO.	RP18AZ24AJVCA	RP18AZ36AJVCA	RP18AZ48AJVCA	RP18AZ60AJVCA
Nominal Tonnage	2.0	3.0	4.0	5.0
Valve Connections				
Liquid Line O.D. – in.	3/8	3/8	3/8	3/8
Suction Line O.D. – in.	3/4	3/4	7/8	7/8
Refrigerant (R-410A) furnished oz.¹	210	212	222	252
Compressor Type	Scroll			
Outdoor Coil				
Net face area – Outer Coil	28.3	32.5	32.5	32.5
Net face area – Inner Coil	—	—	—	—
Tube diameter – in.	0.375	0.375	0.375	0.375
Number of rows	1	1	1	1
Fins per inch	20	20	20	20
Outdoor Fan				
Diameter – in.	26	24	24	26
Number of blades	3	3	3	3
Motor hp	1/2	1/2	1/2	1/2
Shipping weight – lbs.	282	306	306	309
Operating weight – lbs.	278	298	298	301

Electrical Data				
Line Voltage Data (Volts-Phase-Hz)	208/230-1-60	208/230-1-60	208/230-1-60	208/230-1-60
Maximum overcurrent protection (amps)²	30	50	60	60
Minimum circuit ampacity³	22	32	38	42
Compressor				
Rated load amps	15.4	24	28.1	31.7
Locked rotor amps	35	50	50	50

¹Refrigerant charge sufficient for 15 ft. length of refrigerant lines. For longer line set requirements see the installation instructions for information about set length and additional refrigerant charge required.

²HACR type circuit breaker or fuse.

³Refer to National Electrical Code manual to determine wire, fuse, and disconnect size requirements.

Accessories

MODEL NO.	RP2024	RP2036	RP2048	RP2060
EcoNet® Smart Thermostat	RETST800SYS	RETST800SYS	RETST800SYS	RETST800SYS
Heat Pump Riser 6 in.	686020	686020	686020	686020
Supply/Return Sensor	RXHT-A02	RXHT-A02	RXHT-A02	RXHT-A02

Weighted Sound Power Level (dBA)

RP18AZ SOUND POWER LEVEL										
MODEL	SOUND POWER LEVEL [DB(A)] LOW SPEED/ HIGH SPEED	FULL OCTAVE LINEAR SOUND POWER LEVEL DB - CENTER FREQUENCY - HZ								SOUND POWER LEVEL [DB(A)] WITH SOUND BLANKET
		125	250	500	1000	2000	4000	6300	8000	
RP18AZ24AJVCA	59	34.8	39.7	50.8	48.4	42.5	40.2	34.6	34.5	Sound Blankets – Standard
	69	45.0	50.6	59.5	57.9	56.6	49.5	45.7	44.8	
RP18AZ36AJVCA	60	33.6	38.3	57.6	48.2	43.6	39.7	43.0	39.3	
	70	44.8	51.1	60.8	60.1	56.2	50.3	49.9	48.3	
RP18AZ48AJVCA	59	34.0	38.9	52.3	48.0	43.5	39.8	42.2	37.3	
	73	48.5	54.4	65.4	63.1	58.0	55.0	53.3	51.6	
RP18AZ60AJVCA	58	36.0	39.3	51.4	46.2	43.8	43.0	41.3	40.2	
	73	49.8	54.0	68.0	59.2	55.9	53.7	50.7	49.3	

NOTE: Tested in accordance with AHRI Standard 270-08 (not listed in AHRI)

Unit Dimensions

MODEL NO.	OPERATING						SHIPPING					
	H (Height)		L (Length)		W (Width)		H (Height)		L (Length)		W (Width)	
	INCHES	mm	INCHES	mm	INCHES	mm	INCHES	mm	INCHES	mm	INCHES	mm
RP18AZ24AJVCA	45.17	1147	36.13	918	36.13	918	48.18	1224	39.37	1000	39.64	1007
RP18AZ36AJVCA	51.17	1300	36.13	918	36.13	918	53.56	1360	39.37	1000	39.64	1007
RP18AZ48AJVCA	51.17	1300	36.13	918	36.13	918	53.56	1360	39.37	1000	39.64	1007
RP18AZ60AJVCA	51.17	1300	36.13	918	36.13	918	53.56	1360	39.37	1000	39.64	1007

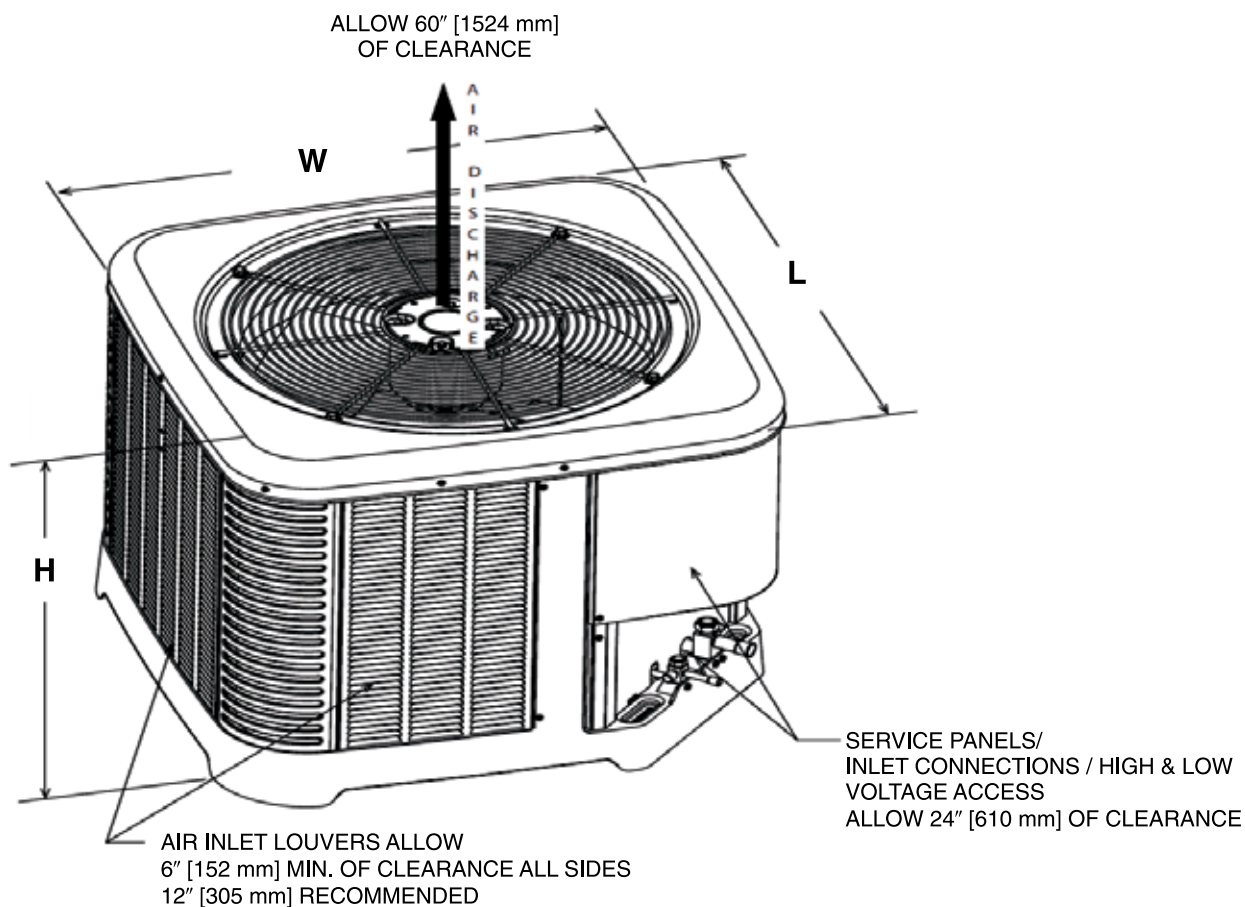

[] Designates Metric Conversions

ST-A1226-02-00

CLEARANCES

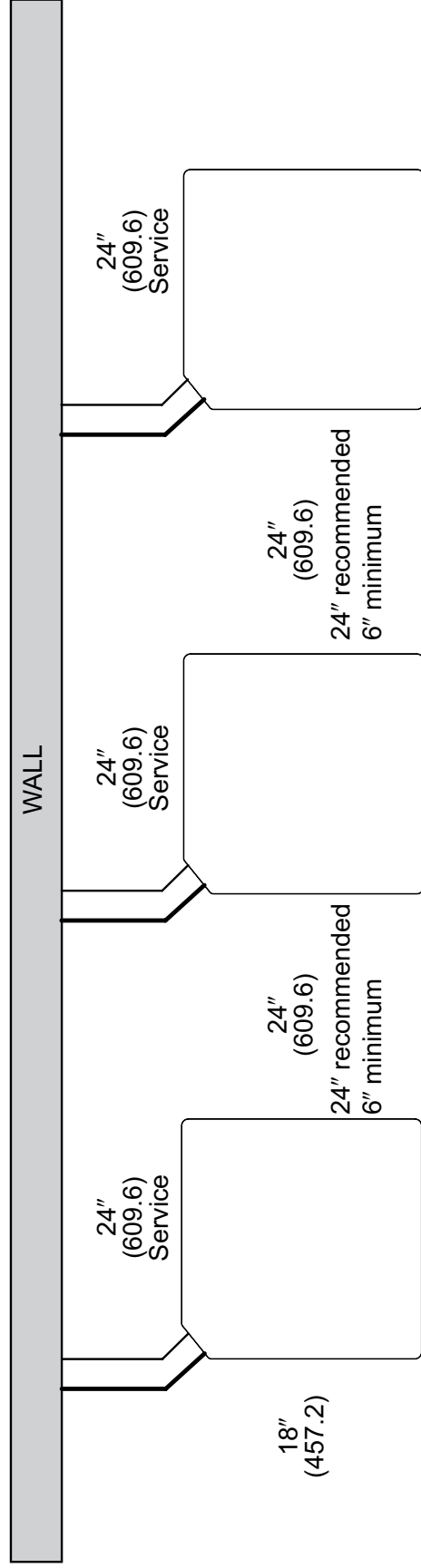
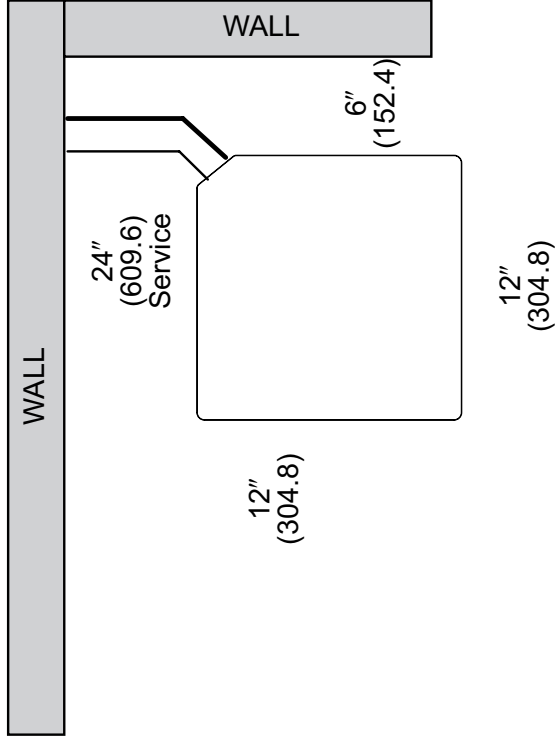
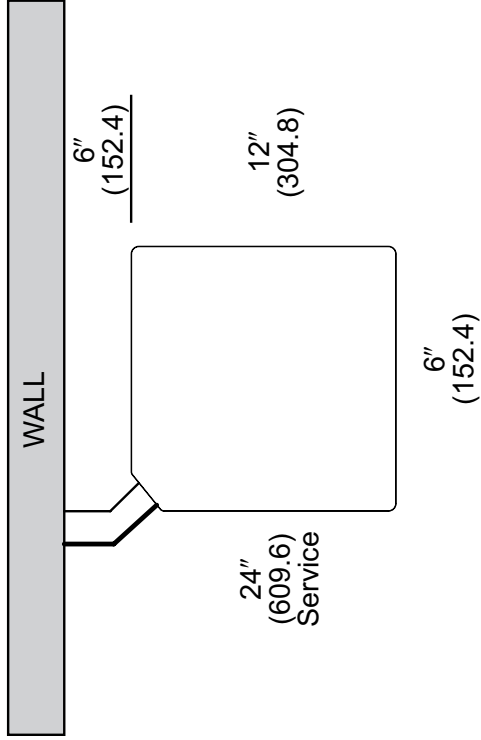

NOTE: NUMBERS IN () = mm

IMPORTANT: When installing multiple units in an alcove, roof well or partially enclosed area, ensure there is adequate ventilation to prevent re-circulation of discharge air.

Refrigerant Line Size Information

18 SEER2 VARIABLE SPEED HEAT PUMPS								
UNIT SIZE	ALLOWABLE LIQUID LINE SIZE	ALLOWABLE VAPOR LINE SIZE	OUTDOOR UNIT ABOVE OR BELOW INDOOR UNIT EQUIVALENT LENGTH (FEET)					
			< 25	26-50	51-75	76-100	101-125	126-150
			MAXIMUM VERTICAL SEPARATION/CAPACITY MULTIPLIER					
2.0 TON *SEE NOTE 3	1/4"	5/8"	25/1.00	50/0.99	33/0.98	60/0.97	NR	NR
	5/16"	5/8"	25/1.00	50/0.99	50/0.98	50/0.97	50/0.96	50/0.95
	3/8"	5/8"	25/1.00	50/0.99	50/0.98	50/0.97	50/0.96	50/0.95
	1/4"	3/4**	25/1.00	50/1.00	33/0.99	60/0.99	NR	NR
	5/16"	3/4**	25/1.00	50/1.00	50/0.99	50/0.99	50/0.99	50/0.98
	3/8"	3/4**	25/1.00	50/1.00	50/0.99	50/0.99	50/0.99	50/0.98
3 TON	5/16"	5/8"	25/0.99	50/0.97	50/0.95	50/0.93	36/0.91	NR
	3/8"	5/8"	25/0.99	50/0.97	50/0.95	50/0.93	50/0.91	NR
	5/16"	3/4"	25/1.00	50/0.99	50/0.99	50/0.98	36/0.97	20/0.96
	3/8"	3/4"	25/1.00	50/0.99	50/0.99	50/0.98	50/0.97	50/0.96
	1/2"	3/4"	25/1.00	50/0.99	50/0.99	50/0.98	50/0.97	50/0.96
4 TON	3/8"	3/4"	25/0.99	50/0.98	50/0.96	50/0.95	50/0.93	50/0.92
	1/2"	3/4"	25/0.99	50/0.98	50/0.96	50/0.95	50/0.93	50/0.92
	3/8"	7/8"	25/1.00	50/0.99	50/0.99	50/0.98	50/0.98	50/0.97
	1/2"	7/8"	25/1.00	50/0.99	50/0.99	50/0.98	50/0.98	50/0.97
5 TON	3/8"	3/4"	25/0.98	50/0.97	50/0.95	50/0.93	46/0.91	NR
	1/2"	3/4"	25/0.98	50/0.97	50/0.95	50/0.93	50/0.91	NR
	3/8"	7/8"	25/0.99	50/0.99	50/0.98	50/0.97	50/0.96	38/0.95
	1/2"	7/8"	25/0.99	50/0.99	50/0.98	50/0.97	50/0.96	50/0.95
	3/8"	1-1/8***	25/1.00	50/1.00	50/1.00	50/0.99	50/0.99	38/0.99
	1/2"	1-1/8***	25/1.00	50/1.00	50/1.00	50/0.99	50/0.99	50/0.99

NOTES:

- 1) Do not exceed 150 ft. linear line length.
- 2) Do not exceed 50 ft. vertical separation between indoor and outdoor units.
- 3) *3/4" vapor line should only be used for 2 ton systems if outdoor unit is below or at same level as indoor unit to assure proper oil return.
- 4) **1-1/8" vapor line should only be used for 5 ton systems if outdoor unit is below or at same level as indoor unit to assure proper oil return.
- 5) Always use the smallest liquid line allowable to minimize refrigerant charge.
- 6) Applications shaded in light gray indicate capacity multipliers between 0.90 and 0.96 which are not recommended, but are allowed.
- 7) Applications shaded in dark gray are not recommended due to excessive liquid or suction pressure drop.

Refrigerant Line Size Information (Con't.)

18 SEER2 VARIABLE SPEED HEAT PUMPS								
UNIT SIZE	ALLOWABLE LIQUID LINE SIZE	ALLOWABLE VAPOR LINE SIZE	OUTDOOR UNIT ABOVE OR BELOW INDOOR UNIT EQUIVALENT LENGTH (METERS)					
			< 8	9-15	16-23	24-30	31-38	39-46
			MAXIMUM VERTICAL SEPARATION/CAPACITY MULTIPLIER					
7.0 kW [2.0 TON] *SEE NOTE 3	6.35 [1/4]	15.88 [5/8]	8/1.00	15/0.99	10/0.98	20/0.97	NR	NR
	7.94 [5/16]	15.88 [5/8]	8/1.00	15/0.99	15/0.98	15/0.97	15/0.96	15/0.95
	9.53 [3/8]	15.88 [5/8]	8/1.00	15/0.99	15/0.98	15/0.97	15/0.96	15/0.95
	6.35 [1/4]	19.05 [3/4]	8/1.00	15/0.99	10/0.99	20/0.99	NR	NR
	7.94 [5/16]	19.05 [3/4]	8/1.00	15/0.99	15/0.99	15/0.99	15/0.99	15/0.98
	9.53 [3/8]	19.05 [3/4]	8/1.00	15/0.99	15/0.99	15/0.99	15/0.99	15/0.98
10.6 kW [3 TON]	7.94 [5/16]	15.88 [5/8]	8/0.99	15/0.97	15/0.95	15/0.93	11/0.91	NR
	9.53 [3/8]	15.88 [5/8]	8/0.99	15/0.97	15/0.95	15/0.93	15/0.91	NR
	7.94 [5/16]	19.05 [3/4]	8/1.00	15/0.99	15/0.99	15/0.98	11/0.97	6/0.96
	9.53 [3/8]	19.05 [3/4]	8/1.00	15/0.99	15/0.99	15/0.98	15/0.97	15/0.96
	12.70 [1/2]	19.05 [3/4]	8/1.00	15/0.99	15/0.99	15/0.98	15/0.97	15/0.96
14.1 kW [4 TON]	9.53 [3/8]	19.05 [3/4]	8/0.99	15/0.98	15/0.96	15/0.95	15/0.93	15/0.92
	12.70 [1/2]	19.05 [3/4]	8/0.99	15/0.98	15/0.96	15/0.95	15/0.93	15/0.92
	9.53 [3/8]	22.23 [7/8]	8/1.00	15/0.99	15/0.99	15/0.98	15/0.98	15/0.97
	12.70 [1/2]	22.23 [7/8]	8/1.00	15/0.99	15/0.99	15/0.98	15/0.98	15/0.97
17.6 kW [5 TON]	9.53 [3/8]	19.05 [3/4]	8/0.98	15/0.97	15/0.95	15/0.93	14/0.91	NR
	12.70 [1/2]	19.05 [3/4]	8/0.98	15/0.97	15/0.95	15/0.93	15/0.91	NR
	9.53 [3/8]	22.23 [7/8]	8/0.99	15/0.99	15/0.98	15/0.97	15/0.96	12/0.95
	12.70 [1/2]	22.23 [7/8]	8/0.99	15/0.99	15/0.98	15/0.97	15/0.96	15/0.95
	9.53 [3/8]	28.58 [1-1/8]**	8/1.00	15/0.99	15/0.99	15/0.99	15/0.99	12/0.99
	12.70 [1/2]	28.58 [1-1/8]**	8/1.00	15/0.99	15/0.99	15/0.99	15/0.99	15/0.99

NOTES:

- 1) Do not exceed 46 meters linear line length.
- 2) Do not exceed 15 meters vertical separation between indoor and outdoor units.
- 3) *19.05mm [3/4"] vapor line should only be used for 2 ton systems if outdoor unit is below or at same level as indoor unit to assure proper oil return.
- 4) **28.58mm [1-1/8"] vapor line should only be used for 5 ton systems if outdoor unit is below or at same level as indoor unit to assure proper oil return.
- 5) Always use the smallest liquid line allowable to minimize refrigerant charge.
- 6) Applications shaded in light gray indicate capacity multipliers between 0.90 and 0.96 which are not recommended, but are allowed.
- 7) Applications shaded in dark gray are not recommended due to excessive liquid or suction pressure drop.

(-)P18AZ24 Cooling Capacity Ranges

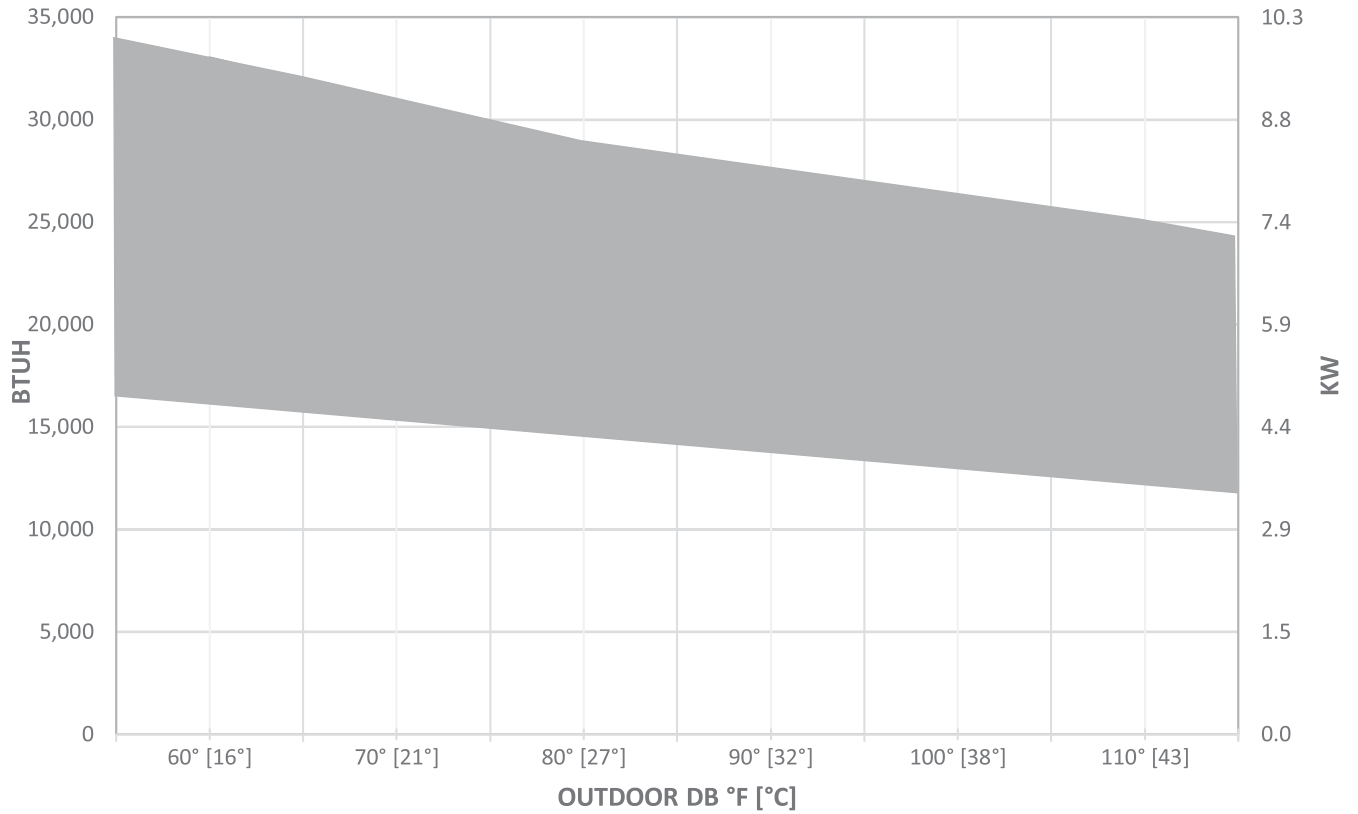

(-)P18AZ24 Heating Capacity Ranges

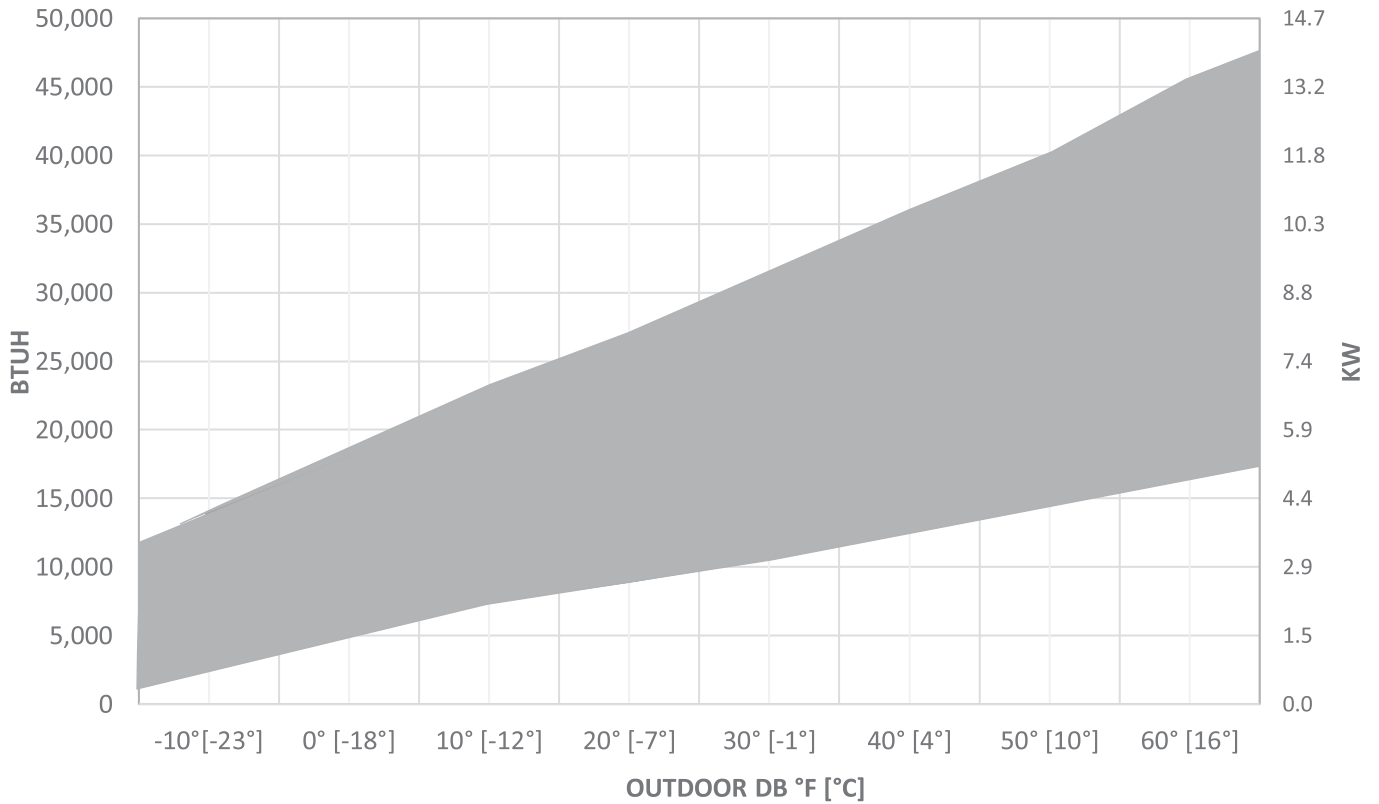

(-)P18AZ36 Cooling Capacity Ranges

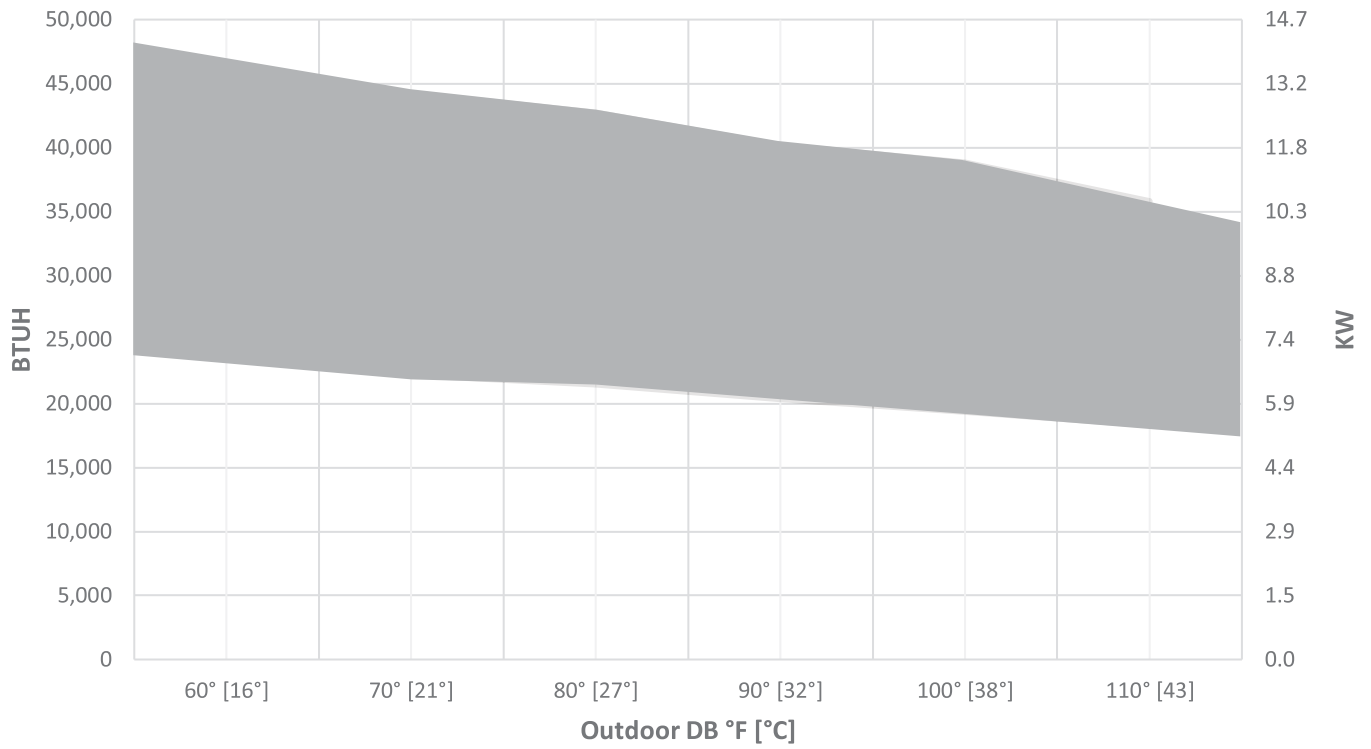

(-)P18AZ36 Heating Capacity Ranges

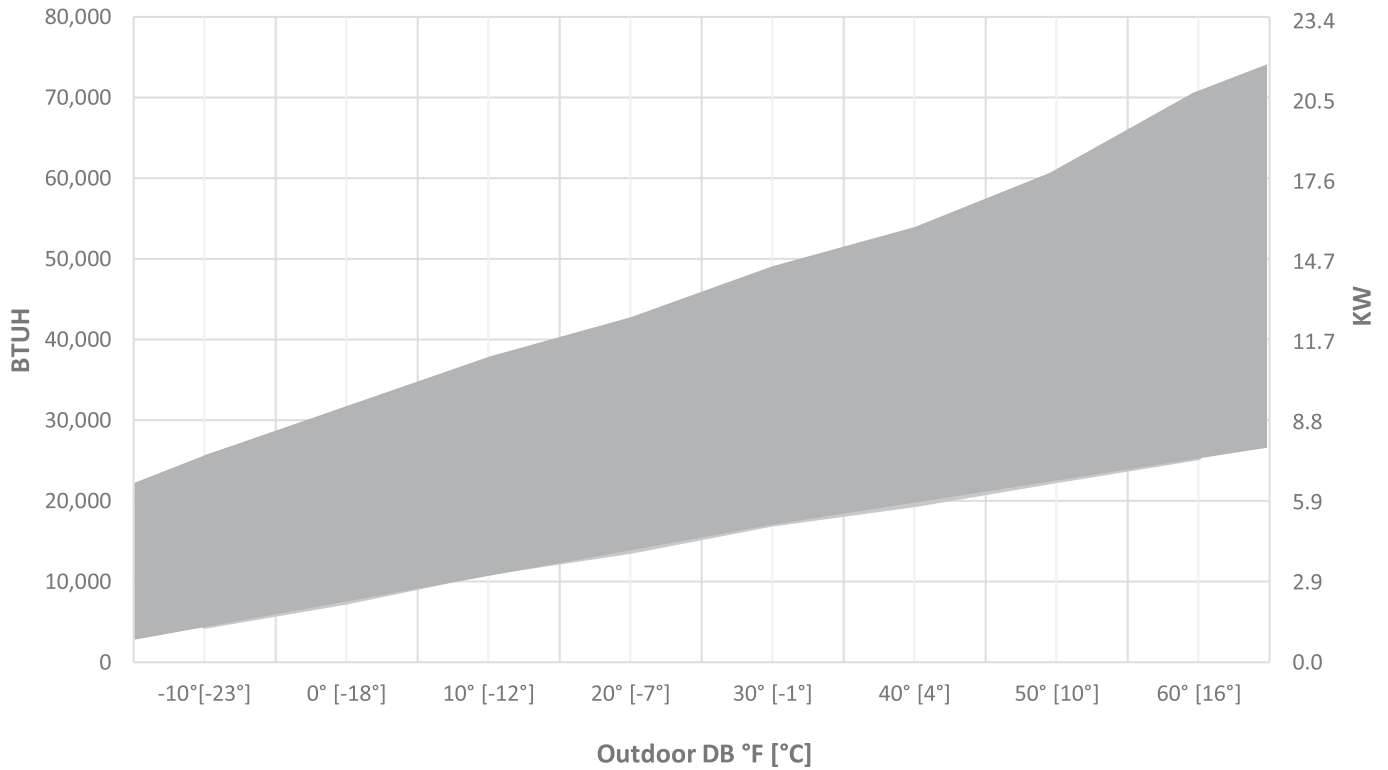

(-)P18AZ48 Cooling Capacity Ranges

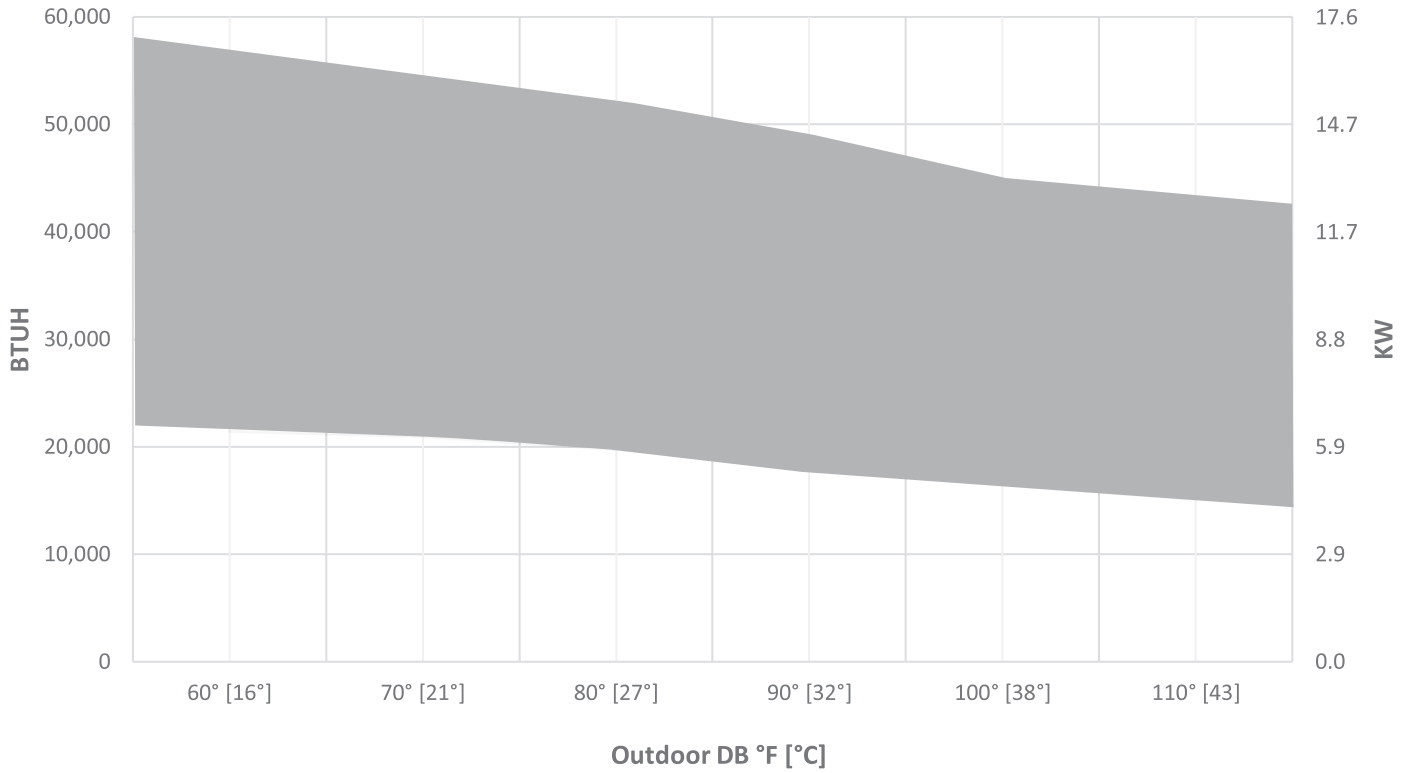

(-)P18AZ48 Heating Capacity Ranges

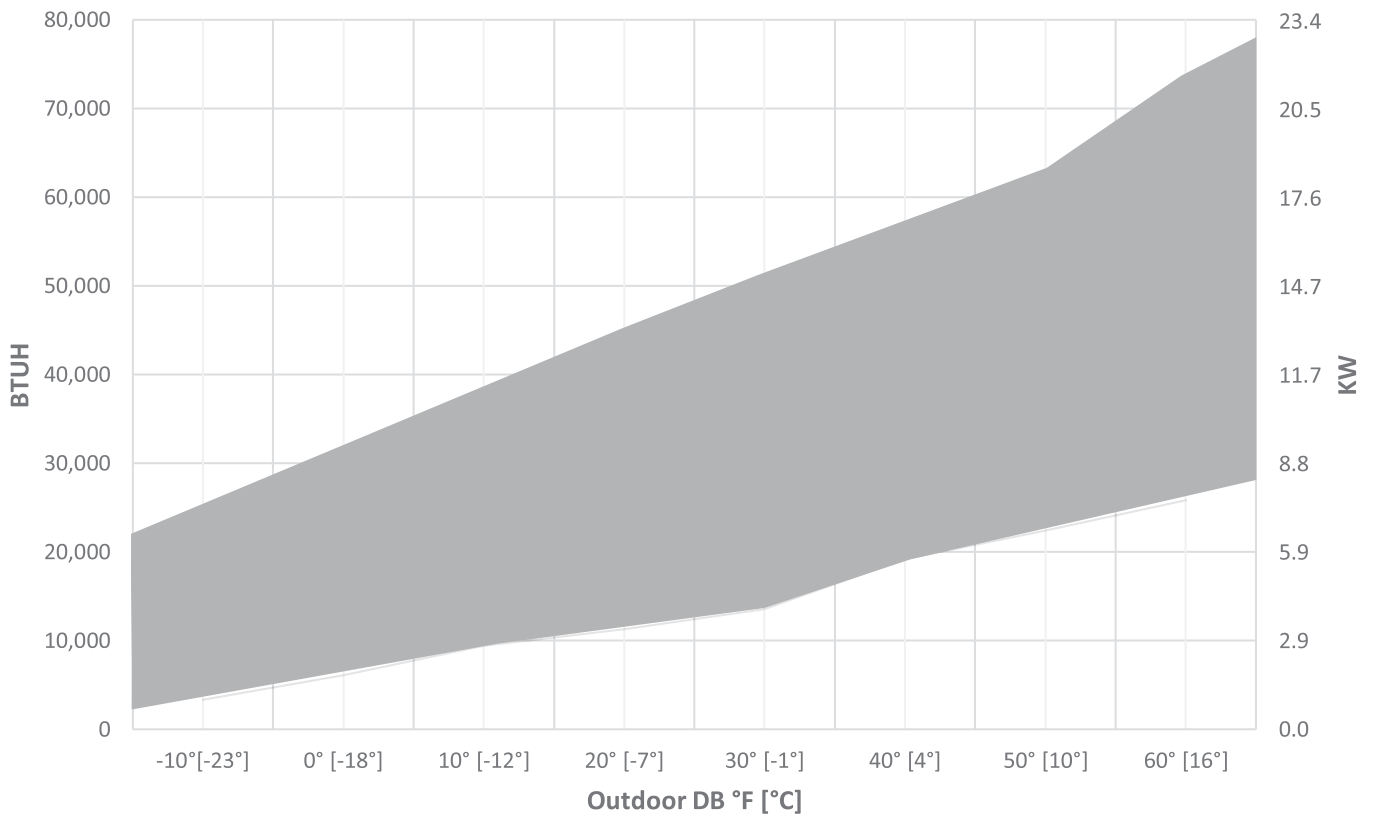

(-)P18AZ60 Cooling Capacity Ranges

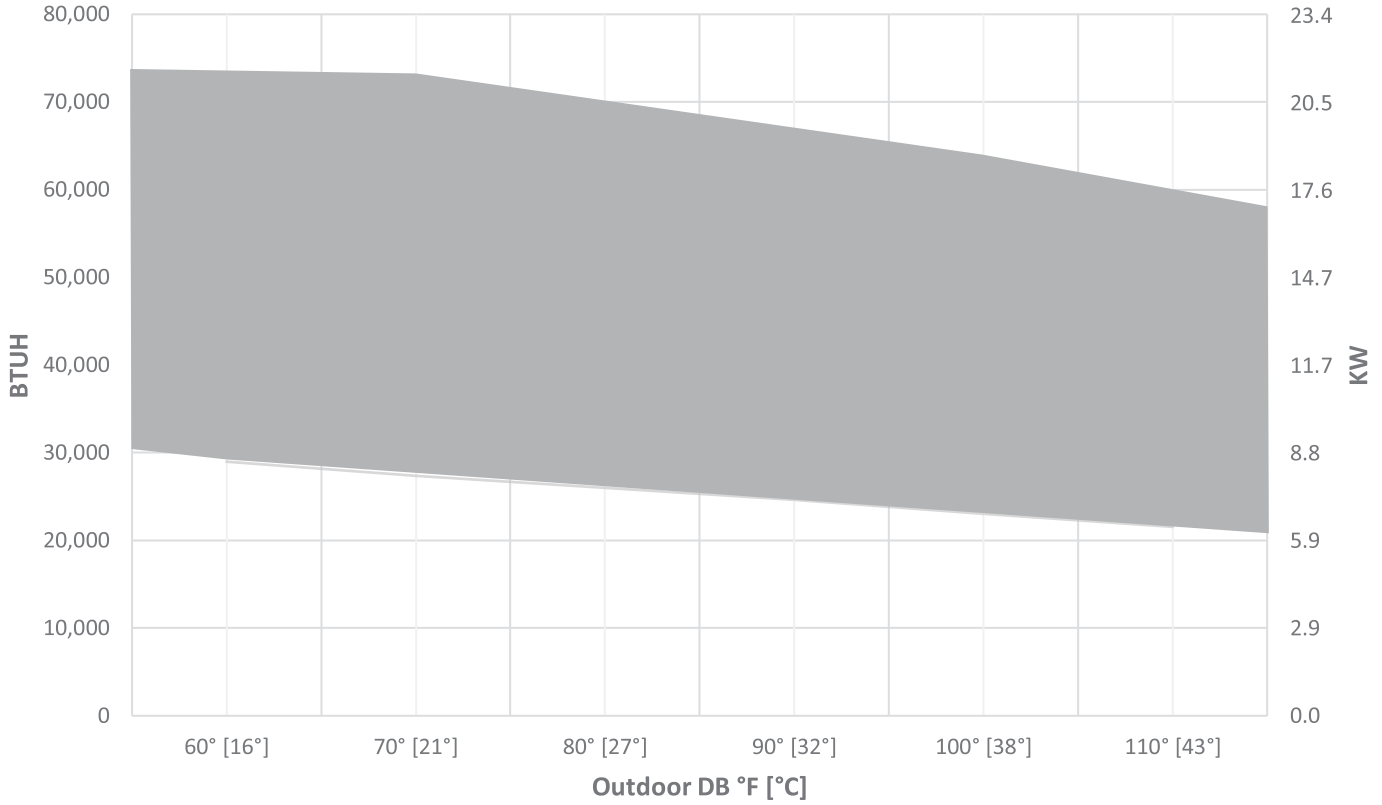

(-)P18AZ60 Heating Capacity Ranges

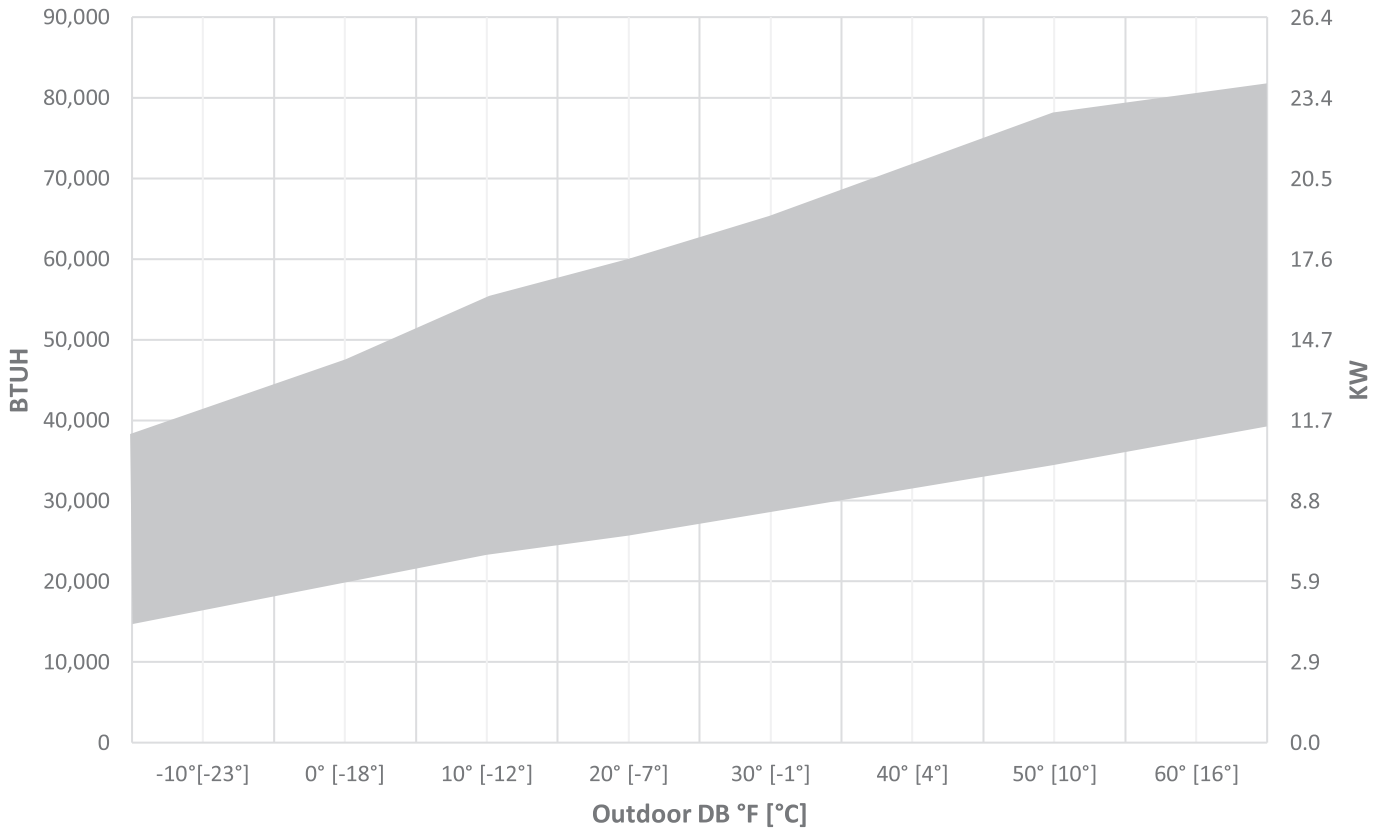

Performance Data @ AHRI Standard Conditions – Cooling

DESIGNATED TESTED COMBINATION (DTC)												
OUTDOOR UNIT	AIR HANDLER	TOTAL CAPACITY BTU/H [kW]	NET SENSIBLE BTU/H [kW]	NET LATENT BTU/H [kW]	SEER2	EER2	INDOOR CFM [L/s]	47 DEGREE HEATING CAPACITY BTU/H [kW]	47 DEGREE COP	17 DEGREE HEATING CAPACITY BTU/H [kW]	17 DEGREE COP	REGION IV HSPF2
RP18AZ24AJVC	RHMVZ2421HEACA	22,800 [6.7]	17,500 [5.1]	5,300 [1.6]	18.0	12.5	785 [370.5]	22,800 [6.7]	3.00	23,000 [6.7]	2.00	8.5
RP18AZ36AJVC	RHMVZ6021SEACA	34,200 [10.0]	26,200 [7.7]	8,000 [2.3]	18.0	12.5	1,225 [578.1]	32,000 [9.4]	3.00	37,400 [11.0]	2.00	8.5
RP18AZ48AJVC	RHMVZ6021SEACA	45,800 [13.4]	34,500 [10.1]	10,500 [3.1]	18.0	12.0	1,590 [750.4]	40,000 [11.7]	2.50	41,000 [12.0]	1.50	8.5
RP18AZ60AJVC	RHMVZ6021SEACA	53,000 [15.5]	40,600 [11.9]	12,400 [3.6]	18.0	10.5	1,685 [795.2]	48,500 [14.2]	2.50	47,000 [13.8]	1.50	8.5

NOTE: This data includes DTC (Designated Test Combination) ratings and is for reference purposes only. A full listing of official ratings and system match-ups, along with downloadable certificates, can be accessed from the AHRI website: www.ahridirectory.org.

[] Designates Metric Conversions

Integrated Controls



EcoNet® is smart, technology developed exclusively by Rheem that allows Heating, Cooling, and Water Heating products to communicate with each other on one integrated network.

THE ECONET® SMART THERMOSTAT

BUILT-IN WIFI

4.3" LCD TOUCH SCREEN

LOCAL WEATHER – Current conditions plus 6-day forecast

5 OPERATING MODES – Heat, Cool, Auto, Emergency Heat and Fan Only

7-DAY PROGRAMMABLE SCHEDULE – Offers comfort without thought

ONE-TOUCH AWAY – Quickly switch to your energy-saving away preferences

VACATION SCHEDULING – Allows you to save while you're away and come home to comfort

STANDBY SCREEN – Displays indoor temperature and current weather



RETST800SYS

OPERATIONAL FEATURES

AUTOMATIC CHANGEOVER – Transitions between heating and cooling automatically to keep the house comfortable

INTEGRATED WATER CONTROL – Enables easy water heater management

SMOOTH ARRIVAL – Prompts the system to start ahead of schedule to ensure the home is at the desired temperature at the scheduled time

HUMIDITY CONTROL – Supports humidifier accessories or over-cool based dehumidification

DETAILED OPERATING STATUS – View pertinent equipment status information and run times

CONTINUOUS FAN – Offers 5 speeds (Low, Medium Low, Medium, Medium High, High)

SHORT-CYCLE PROTECTION – Avoids damage to equipment from short run cycles

MONITORING & REMOTE CONTROL FEATURES

ACTIVE MONITORING – Alerts to problems that need immediate attention

REMOTE CONTROL – Allows adjusting of comfort and settings from anywhere using a mobile device

SERVICE ALERTS – Sends routine maintenance reminders

AIR FILTER MONITORING – Detects when it's time to replace the air filter

ALARM HISTORY – Displays time-stamped alarm codes with clear descriptions



GENERAL TERMS OF LIMITED WARRANTY*

Rheem will furnish a replacement for any part of this product which fails in normal use and service within the applicable period stated, in accordance with the terms of the limited warranty.

Conditional Unit Replacement
(Registration Required)..... Ten (10) Years
Parts Ten (10) Years

***For complete details of the Limited and Conditional Warranties, including applicable terms and conditions, contact your local contractor or the Manufacturer for a copy of the product warranty certificate.**

Before proceeding with installation, refer to installation instructions packaged with each model, as well as complying with all Federal, State, Provincial, and Local codes, regulations, and practices.

© 2024 Rheem Manufacturing Company. Rheem trademarks owned by Rheem Manufacturing Company.

In keeping with its policy of continuous progress and product improvement, Rheem reserves the right to make changes without notice.

5600 Old Greenwood Road
Fort Smith, Arkansas 72908 • www.rheem.com

125 Edgeware Road, Unit 1
Brampton, Ontario • L6Y 0P5 • rheem.ca