



The new degree of comfort.™

SUBMITTAL COVER SHEET

PROJECT NAME _____

LOCATION _____

ARCHITECT _____

ENGINEER _____

CONTRACTOR _____

SUBMITTED BY _____ DATE _____

UNIT SUMMARY

| | | | | | | |
|---------------------|--|--|--|--|--|--|
| Quantity | | | | | | |
| Unit Designation | | | | | | |
| Model No. | | | | | | |
| Total Cooling | | | | | | |
| Sensible Cooling | | | | | | |
| Air Ent. Evaporator | | | | | | |
| Air Lvg. Evaporator | | | | | | |
| Heating Input | | | | | | |
| Heating Output | | | | | | |
| CFM/ESP | | | | | | |
| EER/SEER | | | | | | |
| Electrical | | | | | | |
| Minimum Ampacity | | | | | | |
| Min.-Max. Breaker | | | | | | |
| Net Unit Weight | | | | | | |
| Accessory | | | | | | |
| Catalog Form Number | | | | | | |

ACCESSORIES:

NOTES:





RKHL-D SERIES STANDARD FEATURES INCLUDE:

- R-410A HFC refrigerant
- Complete factory charged, wired and run tested
- Scroll compressors with internal line break overload and high-pressure protection
- Dual independent compressors for two-stage operation
- Downflow only
- TXV refrigerant metering system
- High Pressure and Low Pressure/Loss of charge protection standard on all models
- Solid Core liquid line filter drier
- Single slab, single pass designed evaporator and condenser coils facilitate easy cleaning for maintained high efficiencies
- Cooling operation up to 125 degree F ambient
- Foil faced insulation encapsulated throughout entire unit minimizes airborne fibers from the air stream
- Hinged major access door with heavy-duty gasketing, 1/4 turn latches and door retainers
- Slide Out Indoor fan assembly for added service convenience
- Powder Paint Finish meets ASTM B117 steel coated on each side for maximum protection G90 galvanized
- One piece base pan with drawn supply and return opening for superior water management
- Forkable base rails for easy handling and lifting
- Single point electrical and gas connections
- Internally sloped slide out condensate pan conforms to ASHRAE 62 standards
- High performance belt drive motor with variable pitch pulleys and quick adjust belt system
- Permanently lubricated evaporator, condenser and gas heat inducer motors
- Condenser motors are internally protected, totally enclosed with shaft down design
- 2 inch filter standard with slide out design
- Two stage gas valve, direct spark ignition, and induced draft for efficiency and reliability
- Tubular heat exchanger
- Solid state furnace control with on board diagnostics
- 24 volt control system with resettable circuit breakers
- Colored and labeled wiring
- Copper tube/Aluminum Fin indoor coils with all aluminum MicroChannel condenser coil
- Factory Installed ClearControl™, a Direct Digital Control (DDC) and sensors which can connect to LonWorks™ or BACnet® BAS systems for remote monitoring and control
- Pressure sensors provide refrigerant pressures, superheat, and subcooling on the ClearControl™ display
- H₂AC Package Unit *featuring eSync Integration Technology* includes water circulation pump, refrigerant-to-water heat exchanger, and *eSync Integration Technology* control board for heat recovery during air conditioning mode to preheat potable water.

GAS HEAT / ELECTRIC COOLING PACKAGE DOWNFLOW ONLY

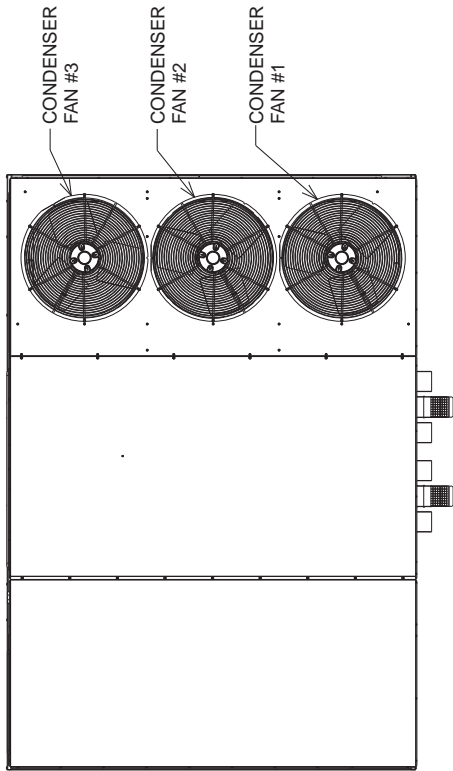

TOP VIEW

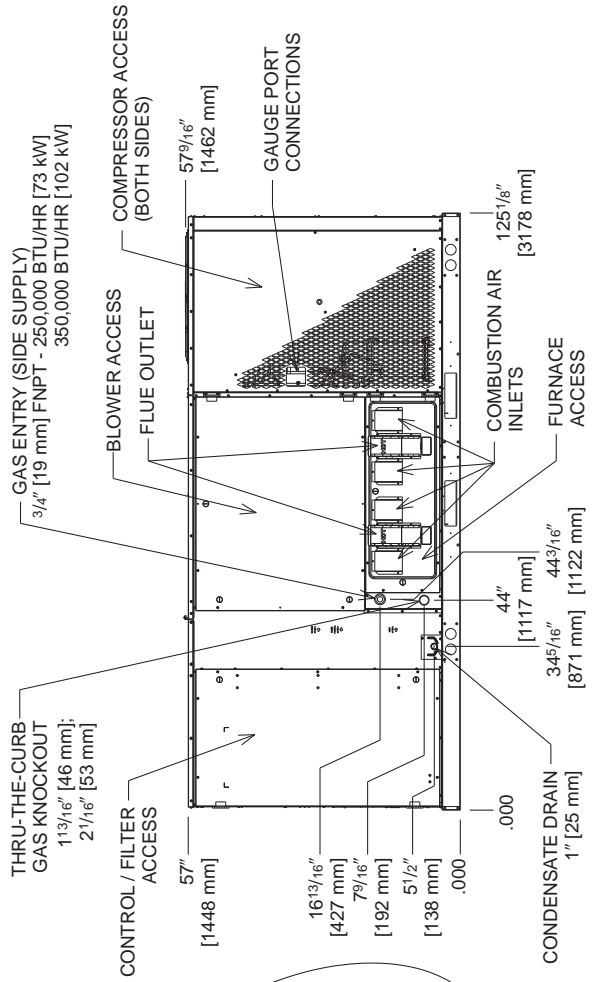

FRONT VIEW

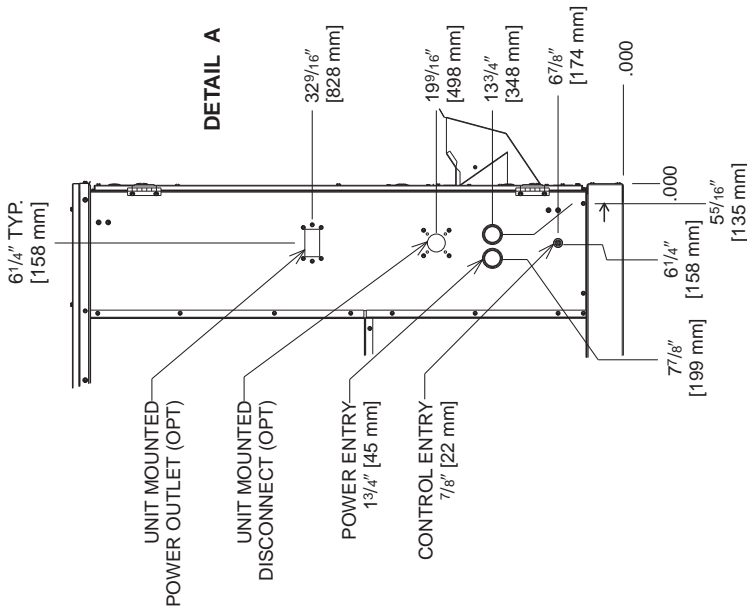

DETAIL A

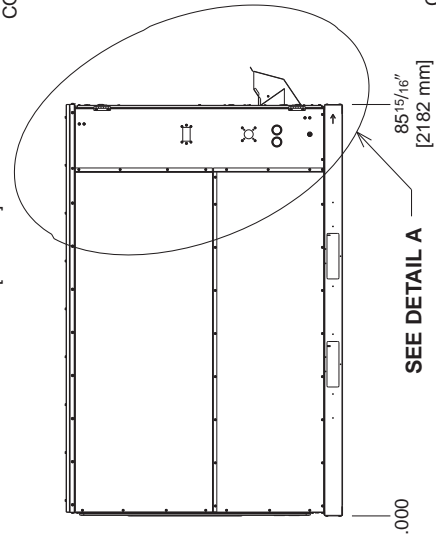

LEFT VIEW

[] Designates Metric Conversions

GAS HEAT / ELECTRIC COOLING PACKAGE DOWNFLOW ONLY

BOTTOM VIEW

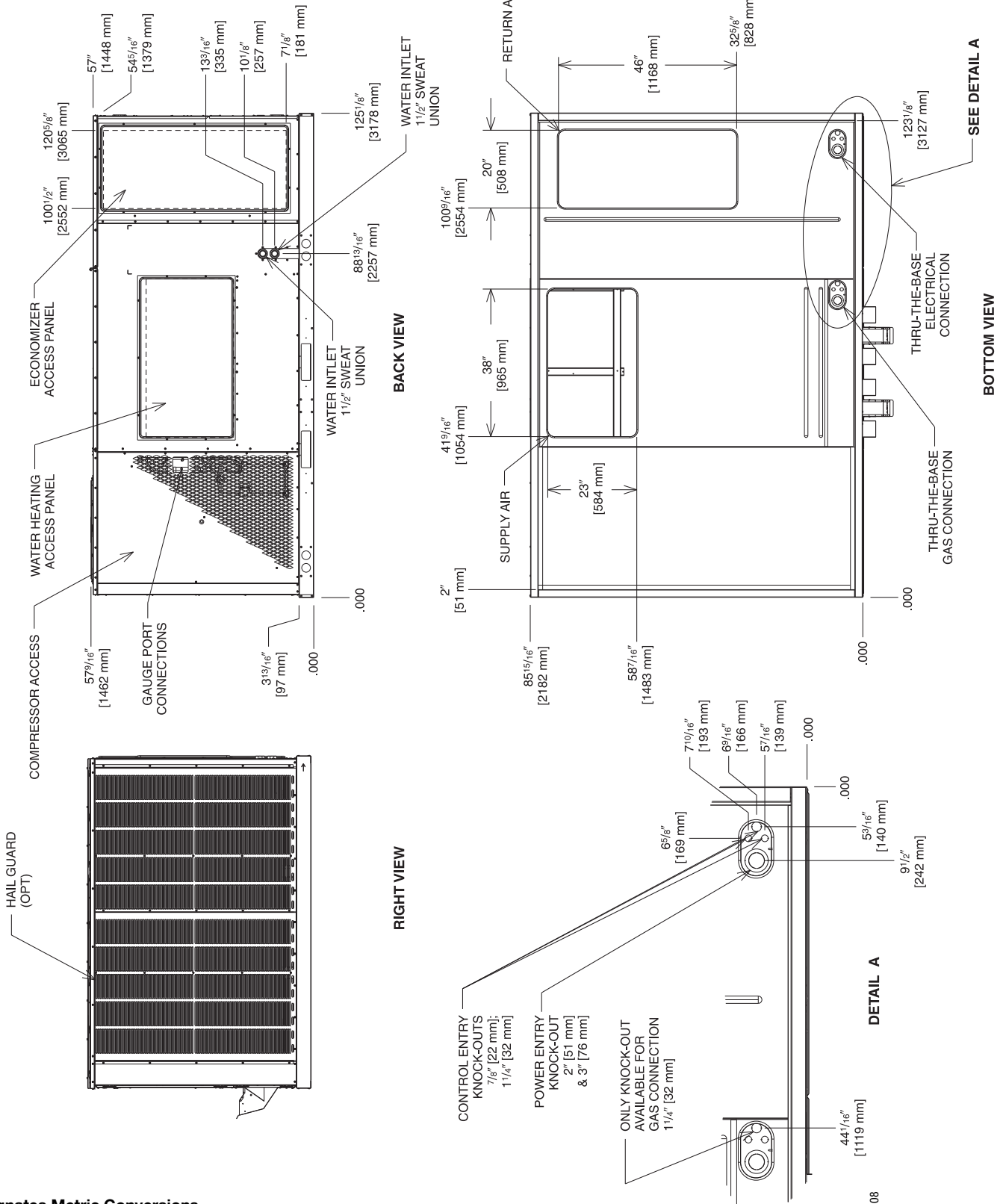

[] Designates Metric Conversions

Illustration
ST-A1207-08