



RHPH STANDARD FEATURES INCLUDE:

- Unit is assembled, wired, charged with R-410A HFC refrigerant and run tested at the factory.
- Scroll compressors with internal line break overload and high-pressure protection.
- Two independent refrigerant circuits each with a scroll compressor provide two stage cooling/heating operation.
- TXV refrigerant metering system on each circuit.
- High Pressure and Low Pressure/Loss of charge protection standard on all models.
- Solid Core liquid line filter drier on each circuit.
- Each evaporator and condenser coil is constructed as a single slab to facilitate easy cleaning for maintaining high efficiencies.
- Cooling operation up to 125 degree F ambient.
- Foil faced insulation encapsulated throughout entire unit minimizes airborne fibers from the air stream.
- Hinged major access door with heavy-duty gasketing, 1/4 turn latches and door retainers.
- Slide Out Indoor fan assembly for added service convenience.
- Powder Paint Finish meets ASTM B117 G90 galvanized steel coated on each side for maximum protection.
- Base pan with drawn supply and return opening for superior water management.
- Convertible airflow – vertical downflow or horizontal sideflow.
- Forkable base rails for easy handling and lifting.
- Single point electrical connections.
- Internally sloped slide out condensate pan conforms to ASHRAE 62 standards.
- High performance belt drive motor with variable pitch pulleys and quick adjust belt system.
- Permanently lubricated evaporator, and condenser motors.
- Condenser motors are internally protected, totally enclosed with shaft down design.
- 2 inch filter standard with slide out design.
- 24 volt control system with resettable circuit breakers.
- Colored and labeled wiring.
- Copper tube/Aluminum Fin coils.
- Supplemental electric heat provides 100% efficient heating.
- Variable Frequency Drive (VFD).
- MERV 8 and MERV 13 filters available as an option.
- Compliant with ASHRAE 90.1-2019 and California Title 24.

SELF-CONTAINED HEAT PUMP

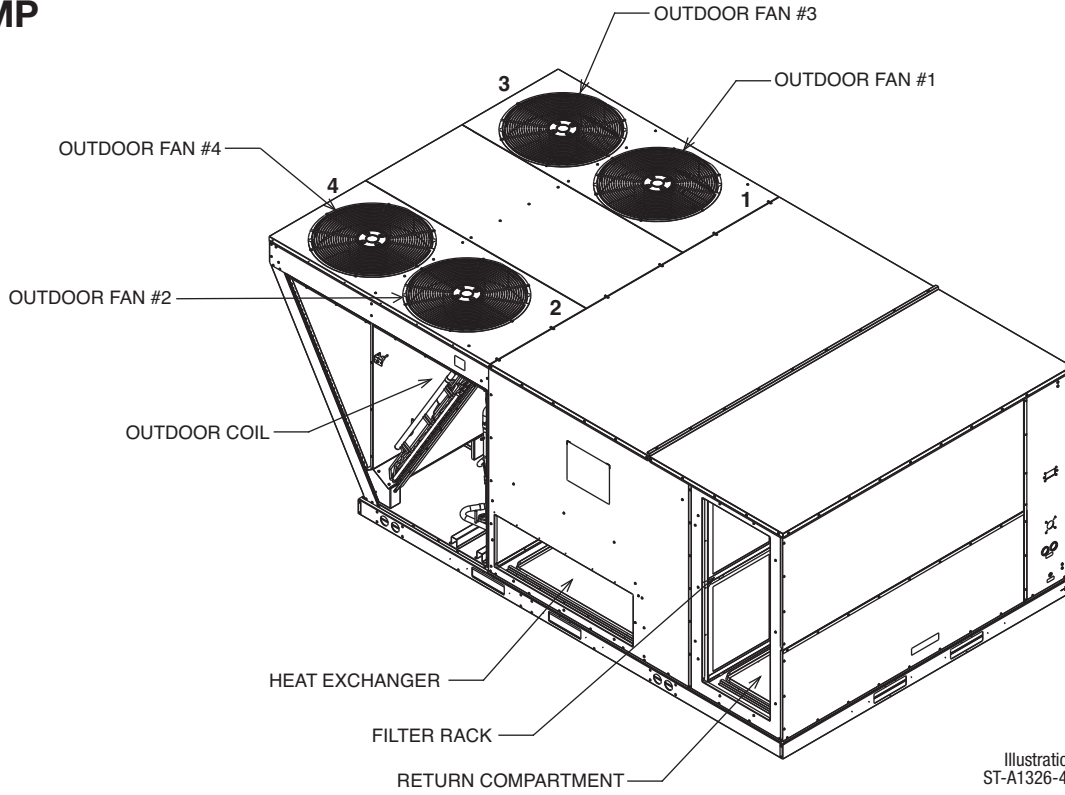
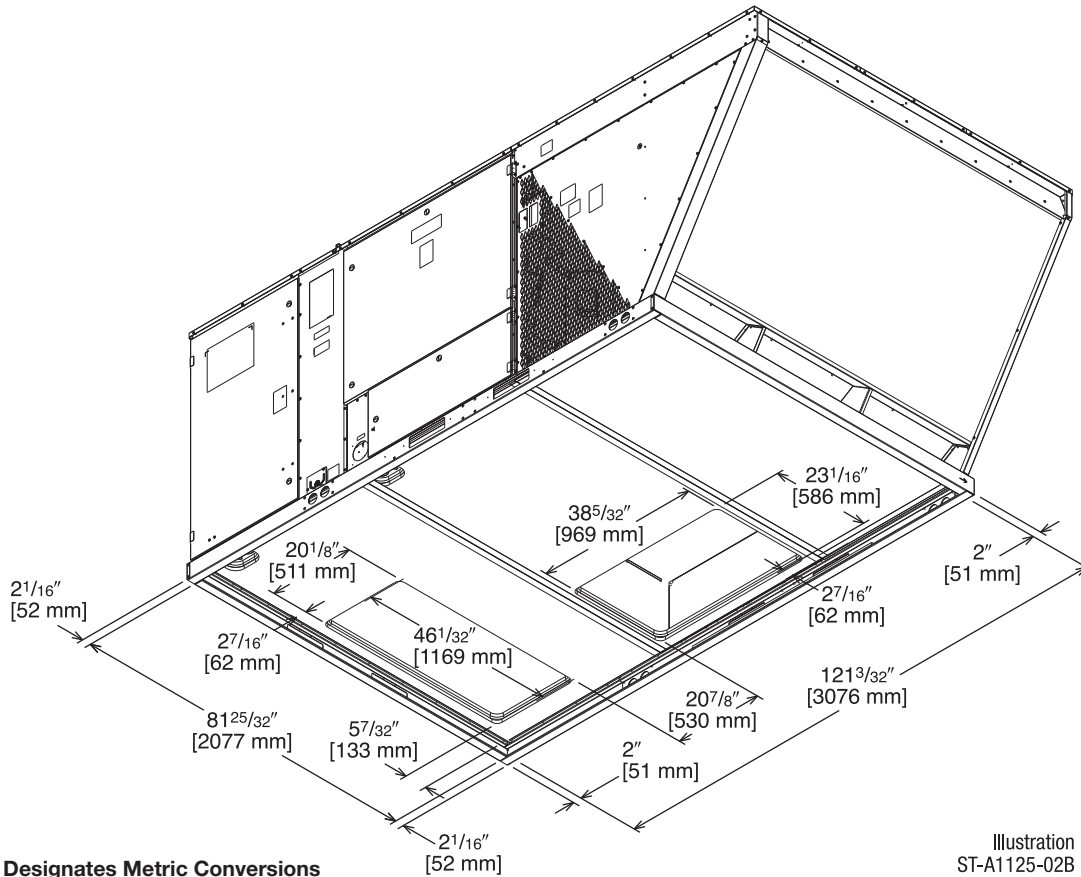

Illustration
ST-A1326-46



BOTTOM VIEW

[] Designates Metric Conversions

Illustration
ST-A1125-02B

SELF-CONTAINED HEAT PUMP

SUPPLY AND RETURN DIMENSIONS FOR HORIZONTAL APPLICATIONS

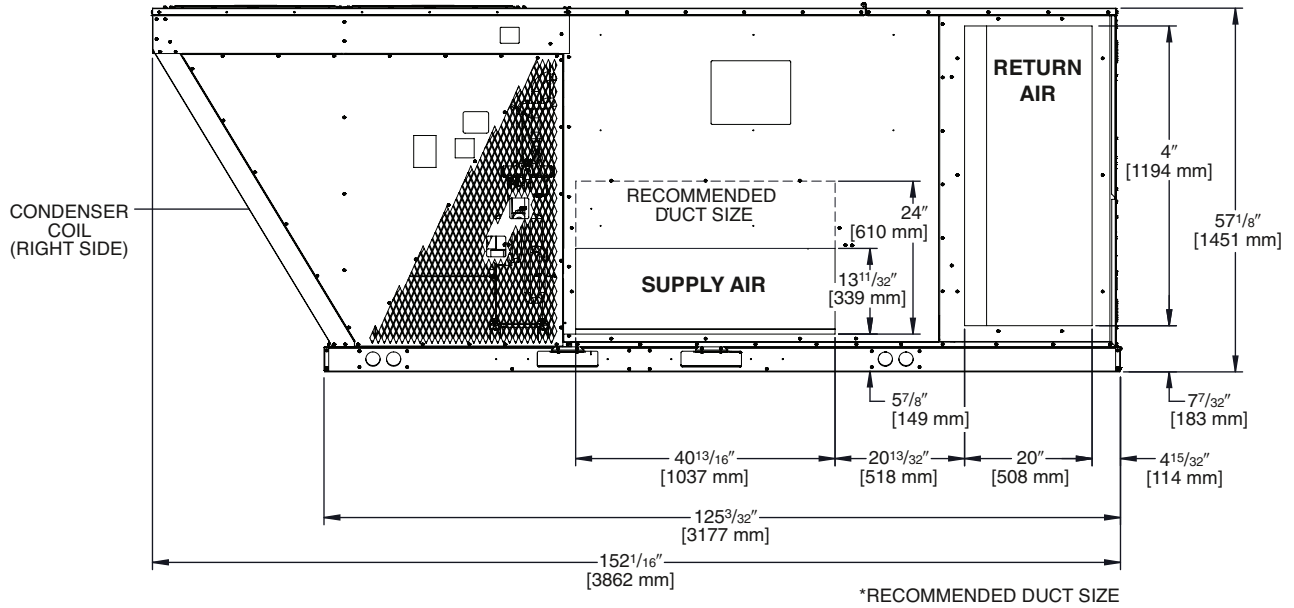

Illustration
ST-A1326-47

DUCT SIDE VIEW (REAR)

SUPPLY AND RETURN DIMENSIONS FOR DOWNFLOW APPLICATIONS

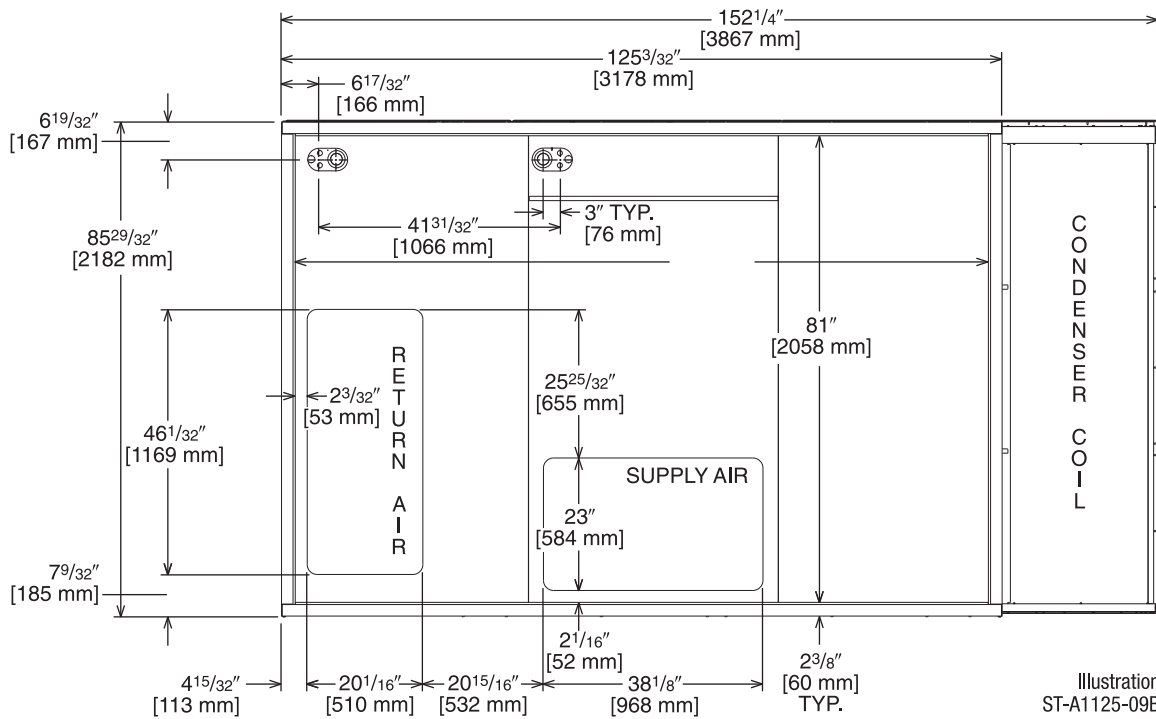

Illustration
ST-A1125-09B

BOTTOM VIEW

[] Designates Metric Conversions

UNIT DIMENSIONS SELF-CONTAINED HEAT PUMP

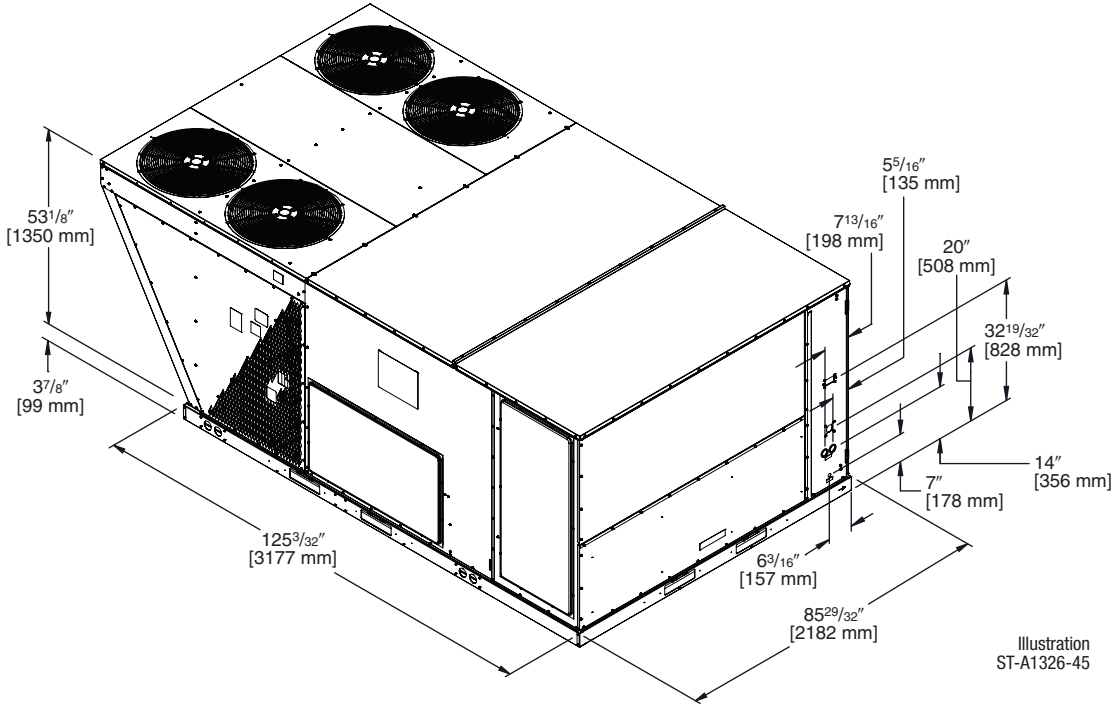

Illustration
ST-A1326-45

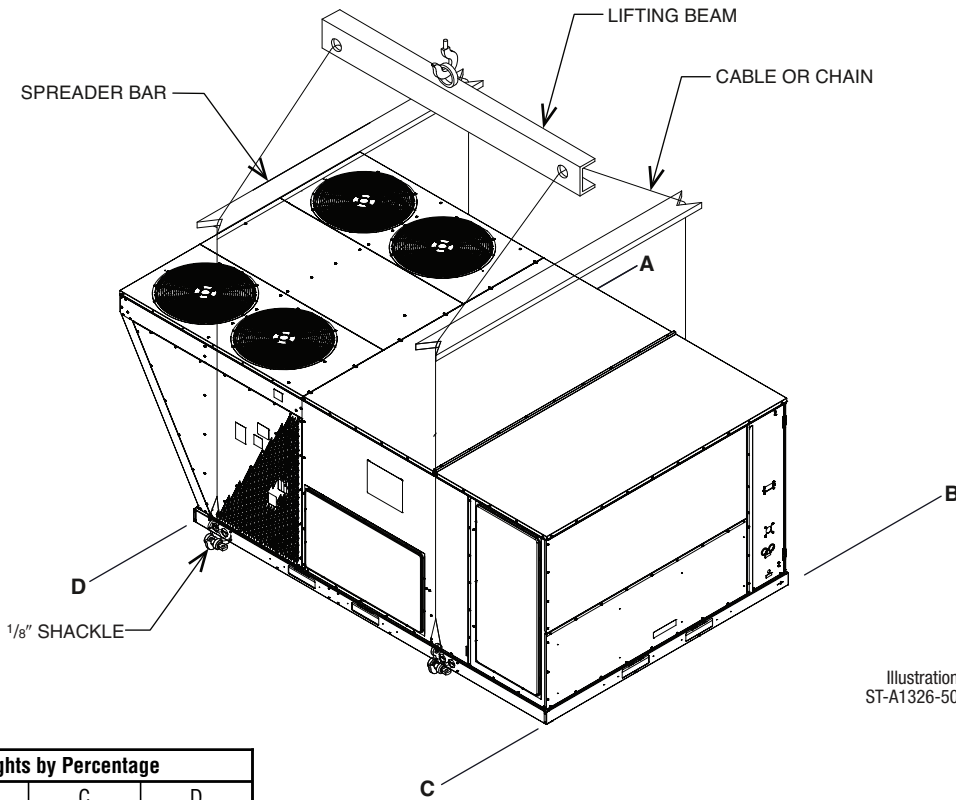

Illustration
ST-A1326-50

WEIGHTS

| Corner Weights by Percentage | | | |
|------------------------------|-----|-----|-----|
| A | B | C | D |
| 32% | 27% | 16% | 24% |

*Note: Corner weights measured at base of unit.

[] Designates Metric Conversions