



Russell[®]
By Rheem

PROJECT NAME _____
LOCATION _____
ARCHITECT _____
ENGINEER _____
CONTRACTOR _____
SUBMITTED BY _____ DATE _____

UNIT SUMMARY

Quantity						
Unit Designation						
Model No.						
Total Cooling						
Sensible Cooling						
Air Ent. Evaporator						
Air Lvg. Evaporator						
Heating Input						
Heating Output						
CFM/ESP						
EER/SEER						
Electrical						
Minimum Ampacity						
Min.-Max. Breaker						
Net Unit Weight						
Accessory						
Catalog Form Number						

ACCESSORIES:

NOTES:

Vantix™ Line S98MV Upflow Gas Furnaces

Heating Stages: Modulating

Input Rates: 60-115 kBTU [11.6-33.7 kW]

JOB NAME _____ LOCATION _____

CONTRACTOR _____ ORDER NO. _____

ENGINEER _____ UNIT MODEL NO. _____

SUBMITTED FOR APPROVAL RECORD COIL MODEL NO. _____

DATE _____ AIR HANDLER MODEL NO. _____

UNIT DATA

HEATING PERFORMANCE

TOTAL CAPACITY INPUT* MBH [kW]

TOTAL CAPACITY OUTPUT* MBH [kW]

DESIGN TEMP. RISE..... °F [°C] DB

AFUE %

CALIFORNIA SEASONAL EFFICIENCY %

(*uses blower motor heat)

SUPPLY AIR BLOWER PERFORMANCE

TOTAL AIR SUPPLY..... CFM [L/s]

TOTAL RESISTANCE EXTERNAL TO UNIT..... IWG

BLOWER SPEED..... RPM

POWER OUTPUT REQUIREMENT BHP

MOTOR RATING HP [W]

POWER INPUT REQUIREMENT kW

ELECTRICAL DATA

POWER SUPPLY..... Hz

TOTAL UNIT AMPACITY..... AMPS

MINIMUM WIRE SIZE..... AWG

MAXIMUM OVERCURRENT DEVICE FUSES/HACR BREAKER AMPS



FEATURES

- **Energy Efficiency:** ENERGY STAR® certified, featuring 98% AFUE across all model sizes
- **Diagnostics:** Industry first, 7-Segment LED Display makes service calls quick and easy
- **Ignition System:** Proven Direct Spark Ignition (DSI) for reliability and longevity
- **Water Management System:** Exclusive patented block drain sensor that automatically shuts off the furnace when the drain is blocked and alerts the contractor via diagnostic code
- **Modulating Heating Stage:** Gradual auto-adjustment from low to 100% of capacity to meet precise comfort requirements
- **Constant CFM Motor:** Truly variable speed technology allows for ultimate humidity control, quieter sounds levels and year-round energy savings
- **Quietest Operation¹:** A fully insulated blower cabinet, solid bottom and truly variable speed airflow technology makes this furnace of the quietest available
- **EcoNet® Enabled Furnace:** The latest in sensor technology and the EcoNet® monitoring system provides a new level of protection, control and energy savings
- **Allows on-the-go control** and receipt of system alerts by the homeowner via the EcoNet® Smart Thermostat and EcoNet® App²

FIELD INSTALLED ACCESSORIES

- Vent Termination Kits Concentric:
- Vert/Horz 2" Pipe (US only) = RXGY-E02
 - Vert/Horz 2" Pipe (US & Canada) = RXGY-E02A
 - Vert/Horz 3" Pipe (US only) = RXGY-E03
 - Vert/Horz 3" Pipe (US & Canada) = RXGY-E03A
 - Direct Vent Furnace Side Wall Vent 2" or 3" (US only) = RXGY-G02
 - External Bottom Filter Rack (Upflow) = RXGF-CB
 - External Side Filter Rack (Upflow) = RXGF-CD



¹Based on manufacturer's furnace offering, and the product's heating stages, motor type and cabinet insulation. Sound levels are also dependent on furnace location and installation.

²Wifi broadband internet connection required. Download the EcoNet® App from the App Store® or Google Play® to set up your EcoNet® Smart Thermostat. Receipt of notifications depend on home WiFi set up. Amazon, Alexa and all related logos are trademarks of Amazon.com, Inc. or its affiliates.

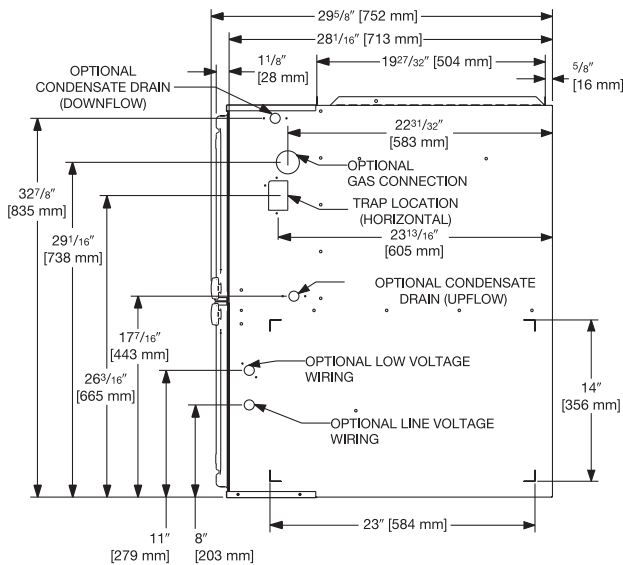
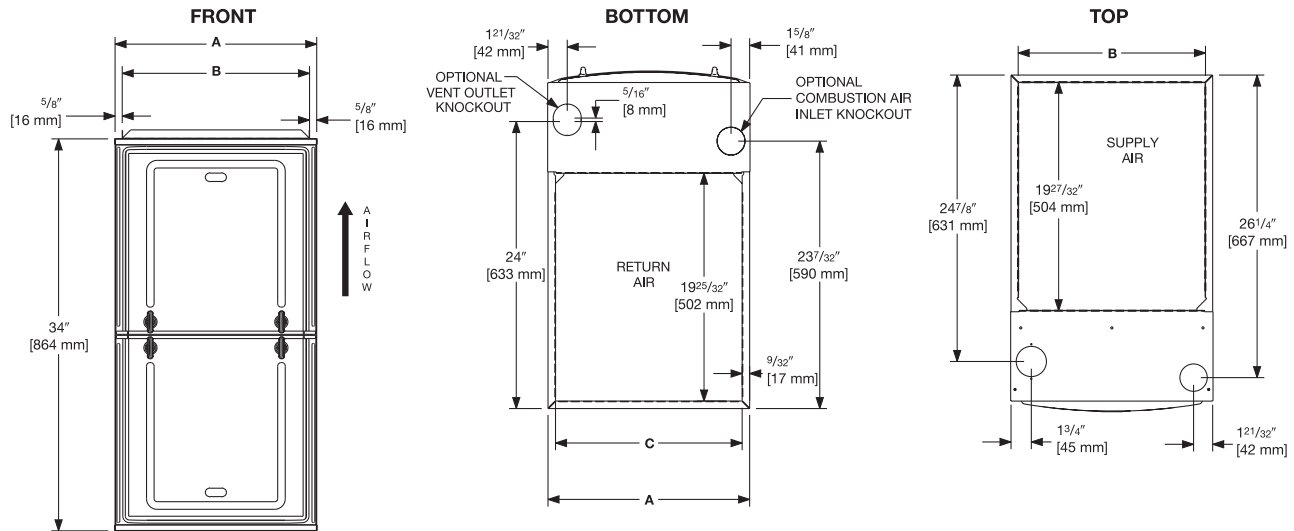

RIGHT SIDE

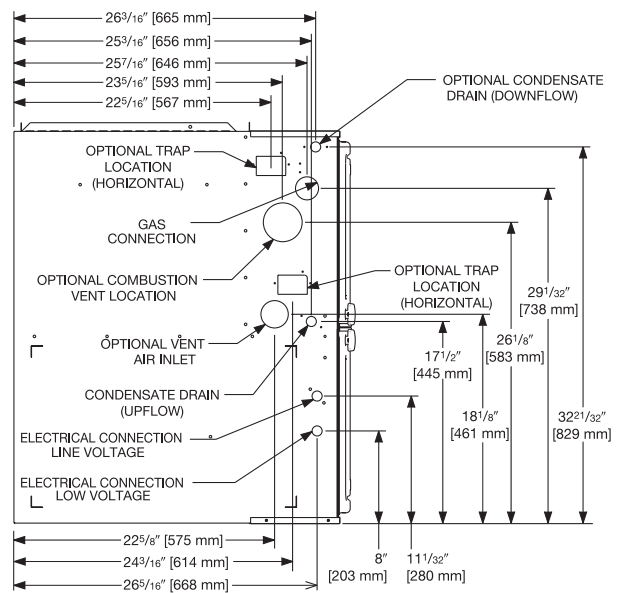

LEFT SIDE

Unit Dimensions

MODEL S98MV	LEFT SIDE	MINIMUM CLEARANCE (IN.) [mm]					FLANGE DIMENSIONS		
		RIGHT SIDE	BACK	TOP	FRONT	VENT	A	B	C
060	0	0	0	1 [25]	2 [51]	0	17 1/2 [445]	16 17/64 [413]	16 13/64 [412]
070	0	0	0	1 [25]	2 [51]	0	17 1/2 [445]	16 17/64 [413]	16 13/64 [412]
085	0	0	0	1 [25]	2 [51]	0	21 [533]	19 49/64 [502]	19 45/64 [500]
100	0	0	0	1 [25]	2 [51]	0	21 [533]	19 49/64 [502]	19 45/64 [500]
115	0	0	0	1 [25]	2 [51]	0	24 1/2 [662]	23 17/64 [591]	23 13/64 [589]

*A service clearance of at least 24" is recommended in front of all furnaces
 Supply and return depicted as upflow configuration.
 Flange configuration will vary depending on installation orientation.

[] Designates Metric Conversions

Before proceeding with installation, refer to installation instructions packaged with each model, as well as complying with all Federal, State, Provincial, and Local codes, regulations, and practices.

5600 Old Greenwood Road
 Fort Smith, Arkansas 72908