

Commercial Gas Water Heater

USE & CARE MANUAL

WITH INSTALLATION INSTRUCTIONS FOR THE CONTRACTOR

MULTI-FLUE COMMERCIAL MODELS

Standard Burner Unit

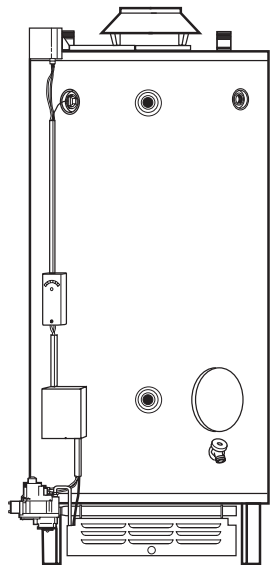

Power Assist Burner Unit *

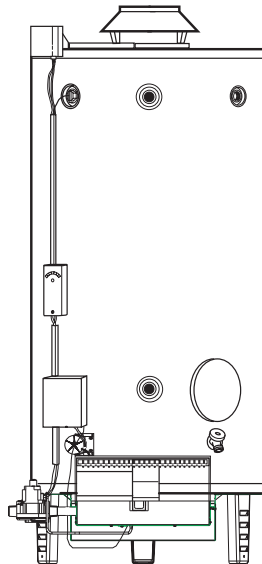

Xtreme Unit *

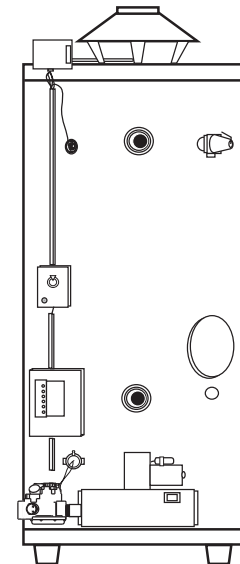

GAS-FIRED
UL
LISTED

Refer to page 9 for an important note regarding initial start-up of this unit!

*Standard burner unit is suitable for natural gas, propane gas and Singapore town gas.

*The Power Assist Burner and Xtreme Units use a system that requires a blower to deliver the air for combustion.



Recognize this symbol as an Indication of Important Safety Information!



Do Not Destroy this Manual. Please read carefully and keep in a safe place for Future Reference.



NOTICE: This water heater is designed for use in a commercial application and the installation and maintenance of it should be performed by a qualified, licensed service personnel. If the foregoing assumption is not appropriate, then we recommend that you obtain and retain our Residential Use & Care Manual.



CALIFORNIA PROPOSITION 65 WARNING: This product contains chemicals known to the State of California to cause cancer, birth defects or other reproductive harm.



WARNING: If the information in these instructions are not followed exactly, a fire or explosion may result causing property damage, personal injury or death.

⚠ FOR YOUR SAFETY!

- Do not store or use gasoline or other flammable vapors or liquids or other combustible materials in the vicinity of this or any other appliance. To do so may result in an explosion or fire.

— WHAT TO DO IF YOU SMELL GAS

- Do not try to light any appliance.
- Do not touch any electrical switch; do not use any phone in your building.

- Immediately call your gas supplier from a neighbor's phone. Follow the gas supplier's instructions.
- If you cannot reach your gas supplier, call the fire department.
- Do not return to your building until authorized by the gas supplier or fire department.
- Improper installation, adjustment, alteration, service or maintenance can cause injury, property damage or death. Refer to this manual. Installation and service must be performed by a qualified installer, service agency or the gas supplier.



General Safety Precautions

Be sure to read and understand the entire Use & Care Manual before attempting to install or operate this water heater. Pay particular attention to the following General Safety Precautions. Failure to follow these warnings could result in a fire or explosion, causing property damage, bodily injury or death. Should you have any problems understanding the instructions in this manual, STOP, and get help from a qualified installer or service technician or the gas supplier.

WARNING

Gasoline, as well as other flammable materials and liquids (adhesives, solvents, etc.), and the vapors they produce, are extremely dangerous. DO NOT handle, use or store gasoline or other flammable or combustible materials anywhere near or in the vicinity of a water heater. Be sure to read and follow the warning label pictured below and other labels on the water heater, as well as the warnings printed in this manual. Failure to do so can result in property damage, bodily injury, or death.

DANGER

Failure to properly vent the water heater to the outdoors as outlined in the Venting Section of this manual can result in unsafe operation of the water heater. To avoid the risk of fire, explosion, or asphyxiation from carbon monoxide, never operate this water heater unless it is properly vented and has an adequate air supply for proper operation. Be sure to inspect the vent system for proper installation at initial start-up; and at least annually thereafter. Refer to Maintenance section of this manual for more information regarding vent system inspections.

DANGER

LIQUEFIED PETROLEUM MODELS — Propane, or LP gas, must be used with great caution.

- It is heavier than air and will collect first in lower areas making it hard to detect at nose level.
- Make sure to look and smell for LP leaks before attempting to light appliance. Use a soapy solution to check all gas fittings and connections. Bubbling at a connection indicates a leak that must be corrected. When smelling to detect an LP leak, be sure to sniff near the floor too.
- Gas detectors are recommended in LP applications and their installation should be in accordance with the manufacturer's recommendations and/or local laws, rules, regulations or customs.
- It is recommended that more than one method be used to detect leaks in LP applications.

IF LP GAS IS PRESENT OR SUSPECTED:

- DO NOT attempt to find the cause yourself;
- DO NOT try to light any appliance;
- DO NOT touch any electrical switch;
- DO NOT use any phone in your building.
- Leave the house immediately and make sure your family and pets leave also.
- Leave the doors open for ventilation and contact the gas supplier, a qualified service agency or the fire department.
- Keep the area clear until the service call has been made, the leak is corrected, and a qualified agency has determined the area to be safe.

WARNING

Both LP and natural gas have an odorant added to help detection. Some people may not physically be able to smell or recognize this odorant. If unsure or unfamiliar about the smell associated with LP or natural gas, ask the gas supplier. Other conditions, such as "Odorant Fade", which causes the odorant to "fade", or diminish in intensity can also hide or camouflage a gas leak.

DANGER

Water heaters utilizing Liquefied Petroleum gas (LP) are different from natural gas models. A natural gas heater will not function safely on LP gas and vice versa. No attempt should ever be made to convert a heater from natural gas to LP gas. To avoid possible equipment damage, personal injury or fire: DO NOT connect this water heater to a fuel type not in accordance with unit data plate. Propane for propane units. Natural gas for natural gas units. These units are not certified for any other type fuel.

WARNING

LP appliances should not be installed below-grade (for example, in a basement) if such installation is prohibited by federal, state and/or local laws, rules, regulations or customs.

! DANGER

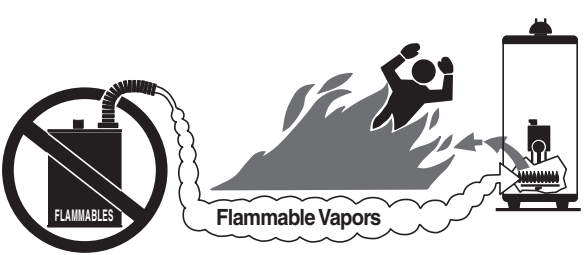

<p>! Vapors from flammable liquids will explode and catch fire causing death or severe burns. Do not use or store flammable products such as gasoline, solvents or adhesives in the same room or area near the water heater. Keep flammable products: 1. far away from heater, 2. in approved containers, 3. tightly closed and 4. out of children's reach.</p>	<p>Water heater has a main burner and pilot flame. The pilot flame: 1. which can come on at any time and 2. will ignite flammable vapors. Vapors: 1. cannot be seen, 2. are heavier than air, 3. go a long way on the floor and 4. can be carried from other rooms to the pilot flame by air currents.</p>
<p>Installation: Do not install water heater where flammable products will be stored or used unless the main burner and pilot flames</p>	<p>are at least 18" above the floor. This will reduce, but not eliminate, the risk of vapors being ignited by the main burner or pilot flame.</p>

Read and follow water heater warnings and instructions. If owners manual is missing, contact the retailer or manufacturer.



General Safety Precautions

To meet commercial water use needs, the thermostat on this water heater is adjustable up to 180°F. However, water temperatures over 125°F. can cause severe burns instantly or death from scalds. This is the preferred starting point for setting the control for supplying general purpose hot water.

Safety and energy conservation are factors to be considered when setting the water temperature on the thermostat. The most energy efficient operation will result when the temperature setting is the lowest that satisfies the needs consistent with the application.

The following chart details the relationship of water temperature and time with regard to scald injury and may be used as a guide in determining the safest water temperature for your applications.

Temperature	Time to Produce Serious Burn
120° F	More than 5 minutes
125° F	1 1/2 to 2 minutes
130° F	About 30 seconds
135° F	About 10 seconds
140° F	Less than 5 seconds
145° F	Less than 3 seconds
150° F	About 1 1/2 seconds
155° F	About 1 second

Table courtesy of Shriners Burn Institute

TIME / TEMPERATURE RELATIONSHIPS IN SCALDS

The temperature of the water in the heater can be regulated by setting the temperature dial on front of the thermostat. To comply with safety regulations the thermostat was set at its lowest setting before water heater was shipped from the factory. The illustration below illustrates the thermostat and how to adjust the water temperature.

! DANGER

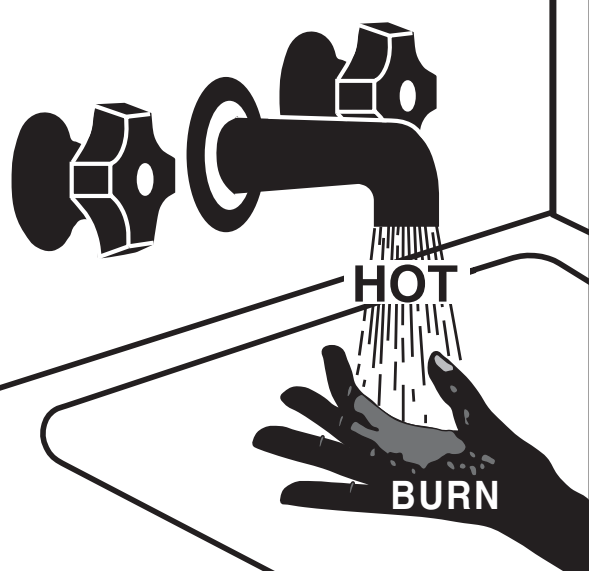

Water temperature over 125°F can cause severe burns instantly or death from scalds.

Children, disabled and elderly are at highest risk of being scalded.

See instruction manual before setting temperature at water heater.

Feel water before bathing or showering.

Temperature limiting valves are available, see manual.

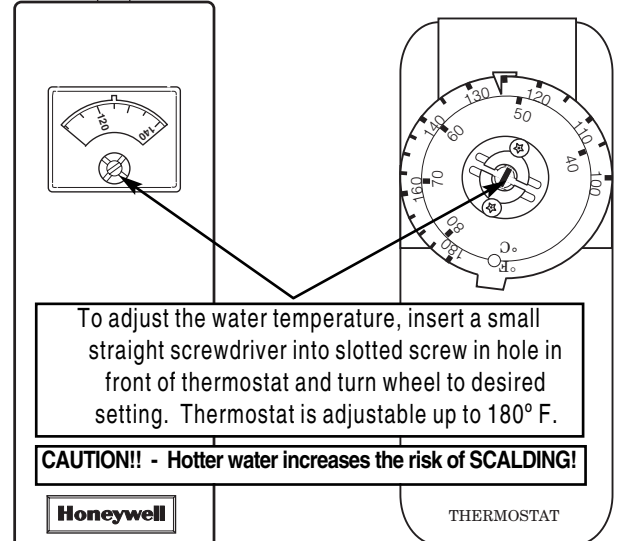

To adjust the water temperature, insert a small straight screwdriver into slotted screw in hole in front of thermostat and turn wheel to desired setting. Thermostat is adjustable up to 180° F.

CAUTION!! - Hotter water increases the risk of SCALDING!

Honeywell
THERMOSTAT

Honeywell
White-Rodgers

NOTE: Each water heater will contain one (1) of the above thermostats. Refer to actual unit to determine which one.

! DANGER

Hotter water increases the Potential for Hot Water SCALDS.

NOTE: Mixing valves are available for reducing point of use water temperature by mixing and cold water in branch water lines Contact a licensed plumber or the local plumbing authority for further information.

Maximum water temperatures occur just after burner has shut off. To find hot water temperature being delivered, turn on a hot water faucet and place a thermometer in the hot water stream and read the thermometer.

Introduction

WARNING

Read and Review this entire Manual with special emphasis on the Draft Hood and Venting Sections (Page 5) and Operation Section (Pages 8 - 11) prior to any installation work

LOCAL INSTALLATION REGULATIONS

This water heater must be installed in accordance with these instructions, local codes, utility company requirements and/or, in the absence of local codes, the latest edition of the National Fuel Gas Code, ANSI Z223.1 in the United States, or CSA/CAN B149 Installation Codes in Canada.

LOCATION

- A. The water heater should be installed in a clean, dry location as close as practical to the gas vent or chimney. Long hot water lines should be insulated to conserve water and energy. The water heater and water lines should be protected from exposure to freezing temperatures.
- B. A gas fired water heater should not be installed in a space where liquids which give off flammable vapors are to be used or stored. Such liquids include gasoline, LP gas (butane and propane), paint or adhesives and their thinners, solvents or removers. Because of natural air movement in a room or other enclosed space, flammable vapors can be carried some distance from where their liquids are being used or stored. The open flame of the water heater's intermittent pilot or main burner can ignite these vapors causing an explosion or fire which may result in severe burns or death to those in range, as well as property damage. For these reasons, installation of a gas fired water heater in a garage is not desirable.

WARNING

If a location in a garage is the only alternative, the gas water heater should be installed so that the open flame of the pilot and main burner are no less than 18 inches above the garage floor. The water heater must be located or protected so it is not subject to physical damage by moving vehicles or area flooding. Raising the gas fired water heater will reduce BUT NOT eliminate the possibility of lighting the vapor of any flammable liquids which may be improperly stored or accidentally spilled.

- C. All models are certified for installation on combustible floors and in alcoves. The minimum side and top clearance to walls and ceiling for providing protection of combustible materials are shown on the water heater's rating label. A front clearance of 18 inches (46 cm) should be provided for adequate inspection and servicing.

If the water heater must be installed on carpeting, place a metal or wood panel beneath water heater extending beyond its full width and depth at least 3 inches (7.6 cm) in all directions. If the water heater is installed in an alcove, the entire floor must be covered by the panel.

CAUTION

The water heater should not be located in an area where leakage of the tank or connections will result in damage to the area adjacent to it or to lower floors of the structure. When such areas cannot be avoided, it is recommended that a suitable catch pan, adequately drained, be installed under the water heater. The pan MUST NOT restrict the flow of combustion air flow to bottom of water heater.

NOTE: Auxiliary catch pan installation MUST conform to the applicable local codes.

- D. **RESTAURANTS** — If the water heater is to be installed in a restaurant or other location where the floor is frequently cleaned, it must be elevated to provide at least six inches (15 cm) of clearance from the floor to comply with NSF International recommendations. A factory-designed leg extension kit is available for this purpose from the distributor or store where the water heater was purchased. (Currently unavailable for GX90 models)
- E. **COMBUSTION & VENTILATION AIR** — Proper operation of the water heater requires air for combustion and ventilation. If the water heater is installed in a building of conventional frame, masonry or metal construction, and there are no other appliances installed that require an air supply, infiltration air is normally adequate for proper combustion and ventilation, and an outside air supply for the water heater may not be required. However, if the water heater is installed in a confined space, or the building is of unusually tight construction, then an outside air supply must be provided. Provisions for Combustion and Ventilation air must comply with the applicable codes and standards as defined in the Local Installation Regulations section on page 4.

FOR INSTALLATIONS IN THE UNITED STATES:

If the water heater is to be installed in a confined space, defined as one having a volume of less than 50 cubic feet (1.4 cu. meters) per 1000 Btu/h of the total input of all appliances within that space, an air supply must be provided. The air must be supplied through two permanent openings of equal area, one of which is to be located approximately 12 inches (30cm) above the floor and the other of which is to be located approximately 12 inches (30cm) below the ceiling. The minimum net free area of each opening must be not less than one square inch per 1000 Btu/h of the total input of all the appliances in the enclosure or structure, if each of the openings communicates with other unconfined areas inside the structure.

If the required air is to be supplied directly from outdoors (or a freely ventilated attic or crawl space), or through vertical ducts, there must be two openings located as specified above, and each must have a minimum net free area of not less than one square inch (6.5 sq. cm) per 4,000 Btu/h of the total input rating of all appliances in the enclosure.

If horizontal ducts are used to communicate with the outdoors, each opening must have a minimum net free area of not less than one square inch (6.5 sq. cm) per 2000 Btu/h of the total input rating of all appliances in the enclosure.

NOTE: If the openings are to be covered with a protective screen or grill, the net free area of the covering material must be used in determining the size of the openings mentioned above. Protective screening for the openings MUST NOT be smaller than 1/4 inch (.64 cm) mesh to resist clogging by lint or other debris.

For additional information regarding combustion and ventilation air supply requirements, refer to the latest edition of the American National Standard / National Fuel Gas Code, ANSI Z223.1

FOR INSTALLATIONS IN CANADA:

While the requirements for U.S. installations outlined above are generally true in Canada, precise requirements for combustion and ventilation air supplies are detailed in the CAN/CSA B149 Installation Codes; under "Venting Systems and Air Supply for Appliances". To ensure that the water heater is properly installed,

Introduction

those requirements must be followed.

Large exhaust fans can lower the air pressure inside a building or room and interfere with proper venting and operation. Commercial kitchens or other locations that must maintain a high flow of exhaust air should have the water heater installed in a separate room with combustion and ventilation air supplied directly from outside as described above.

- F. CORROSIVE ATMOSPHERES** — The heater should not be installed near an air supply containing halogenated hydrocarbons. For example, the air in beauty shops, dry cleaning establishments,

photo processing labs, and storage areas for liquid and powdered bleaches or swim pool chemicals often contain such hydrocarbons. The air there may be safe to breathe, but when it passes through a gas flame, corrosive elements are released that will shorten the life of any gas burning appliance. Propellants from common spray cans or gas leaks from refrigeration equipment are highly corrosive after passing through a flame. The limited warranty is voided when failure of water heater is due to a corrosive atmosphere. (Reference is made to the limited warranty for complete terms and conditions.)

Installation

WARNING

The manufacturer's warranty does not cover any damage or defect caused by installation, or attachment, or use of any special attachment such as energy saving devices (other than those authorized by the manufacturer) into, onto, or in conjunction with the water heater. The use of such unauthorized devices may shorten the life of the water heater and may endanger life and property. The manufacturer disclaims any responsibility for such loss or injury resulting from the use of such unauthorized devices.

- 1. INSPECT SHIPMENT** — for possible damage. The manufacturer's responsibility ceases upon delivery of goods to the carrier in good condition. Any claims for damage, shortage in shipments, or non delivery must be filed immediately against carrier by consignee.
- 2. DRAFT HOOD** — The combination draft hood - flue damper assembly designed for and shipped with this water heater must be installed, without alteration, directly on the flue outlet collar. **DO NOT** substitute any other size or type of draft hood.

Before proceeding with installation, verify that the part number on the draft hood - flue damper assembly matches that called for on label near connector. If not, see your distributor or the store from where the water heater was purchased.

- A.)** Place the draft hood - flue damper assembly on the flue outlet of the water heater with the drive motor to the left front. Rotate as necessary to position where the plug on the end of the wire harness can freely engage in the receptacle of the drive motor.

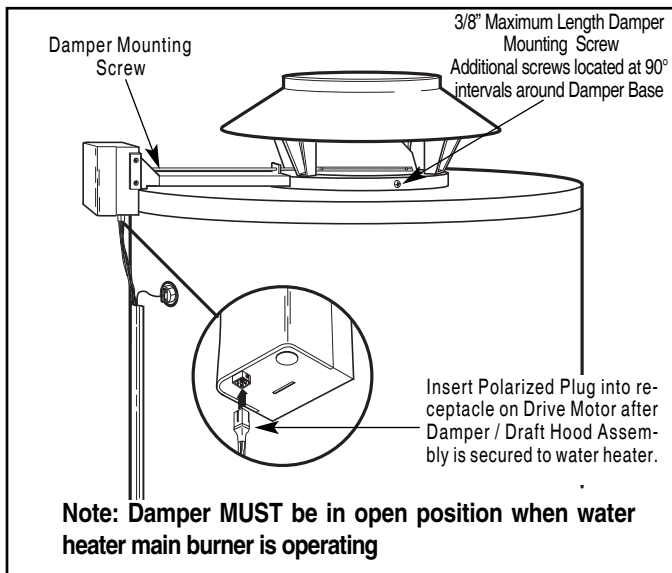

Figure 3. — Installing Damper / Draft Hood Assembly

- B.)** Mark a spot on top pan through the hole in support bracket at the rear of the drive motor. (Refer to Figure 3.)
- C.)** Remove the draft hood - flue damper assembly and drill a hole through the spot for securing it with sheet metal screw.
- D.)** Reinstall the draft hood - flue damper assembly and secure it with a sheet metal screw through the support bracket. Also install three (3) 3/8" (.95 cm) maximum length self drilling screws (supplied with Damper Assembly) into holes located around the base of Damper Assembly. (Refer to Figure 3.)
- E.)** Electrical connections to the drive motor are made with a plug that is polarized to insure correct insertion. The drive motor receptacle is external to the casing for easy access. (Refer to Figure 3.)

- 3. VENTING** — The responsibility for providing a vent of adequate capacity and in good usable condition is that of the installing contractor. There is a limit to the Btu/h capacity of any given vent or chimney style and height. For installations in the United States, capacity tables are printed in Appendix "G" of the National Fuel Gas Code (ANSI Z223.1). For installations in Canada, this information is contained in Appendix B of CAN/CSA B-149 Installation Codes. As an alternate method for sizing a vent connected to more than one appliance, the effective area of the vent shall be not less than the area of the largest vent connector plus 50% of the areas of additional draft hood outlets.

Any horizontal run of vent connector connecting the draft hood to the gas vent or chimney, must have an upward slope of at least 1/4" per foot of length. Single wall vent connectors must be at least 6" from adjacent unprotected combustible surfaces. Joints of vent connectors should be securely fastened by sheet metal screws or other approved method. Provide support for vent, or vent connectors to keep weight off draft hood.

- 4. GAS SERVICE** — The inlet gas pressure to the water heater must not exceed 10.5" w.c. (2.6 kPa) for Natural gas and 13.0" w.c. (3.2 kPa) for L.P. gas. Note: The Power Assist Burner Unit uses only Natural Gas and should follow the guidelines stated in the previous sentence for inlet gas pressure. For purposes of input adjustment, the minimum inlet gas pressure (with main burner on) is shown on the rating plate. Check to see if high or low gas pressure is present and then contact the gas company for correction.

The inlet gas pressure to the water heater should be at least 4" w.c. (1.0kPa) for Singapore town gas. Manifold pressure should be adjusted to 2.5" w.c. (0.63 kPa).

The gas line should be of adequate size to prevent undue pressure drop. Sizing based upon Table 1 (on pg. 14) is recommended. No additional allowance is necessary for an ordinary number of fittings.

A ground joint union and manual shutoff valve should be installed in the gas line near the water heater so that the burner assembly may be easily removed. The shut-off valve must be readily accessible for turning on or off. See Fig. 4 or 5 on page 6.

Installation

NOTES:

- 1.) Heater's Outlet Piping must have upward slope, otherwise use Circulator
- 2.) If Vertical Tank is used, follow same lay-out.
- 3.) Figure depicts the "Power Assist Burner", but all burner systems applies.
- 4.) The gas supply piping must be adequately supported and aligned to minimize loads (forces) on the water heater's gas valve and burner system.

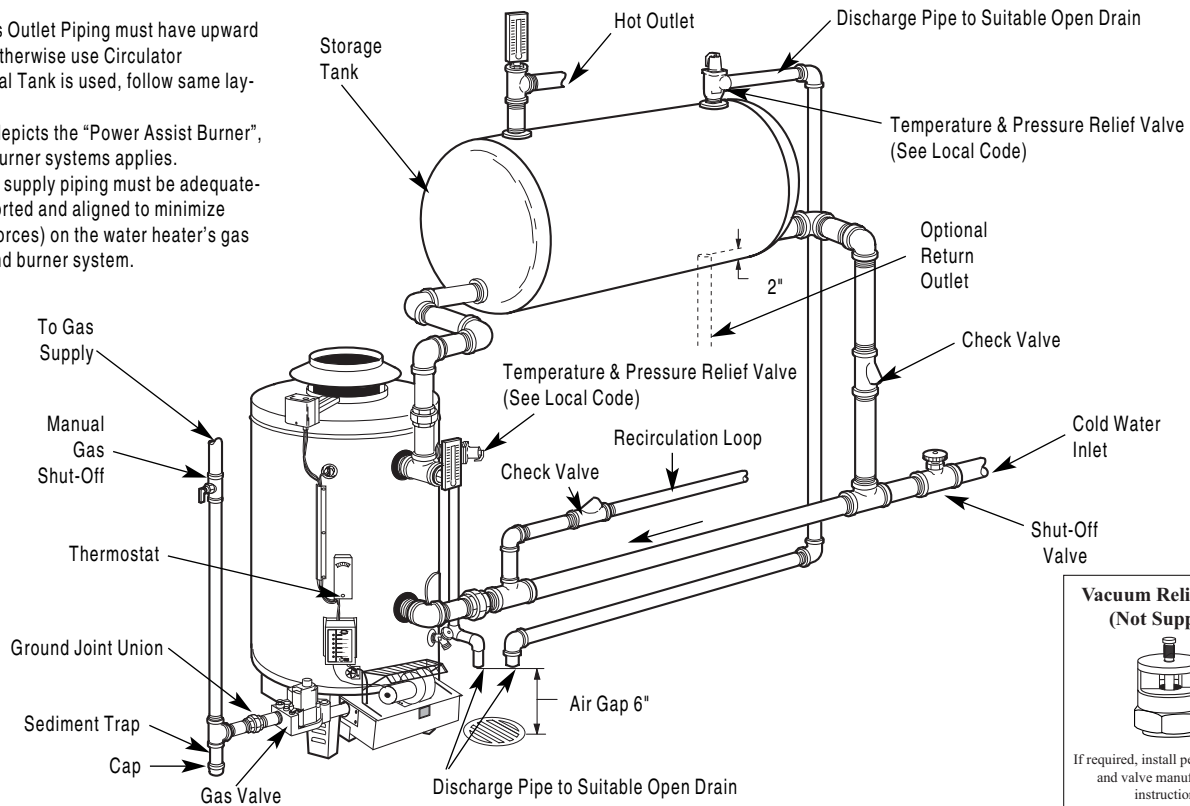

Vacuum Relief Valve (Not Supplied)

If required, install per local codes and valve manufacturer's instructions.

Figure 4. — Typical Gravity Circulating System

NOTES:

- 1.) Figure depicts the "Standard Burner", but all burner systems applies.
- 2.) The gas supply piping must be adequately supported and aligned to minimize loads (forces) on the water heater's gas valve and burner system.

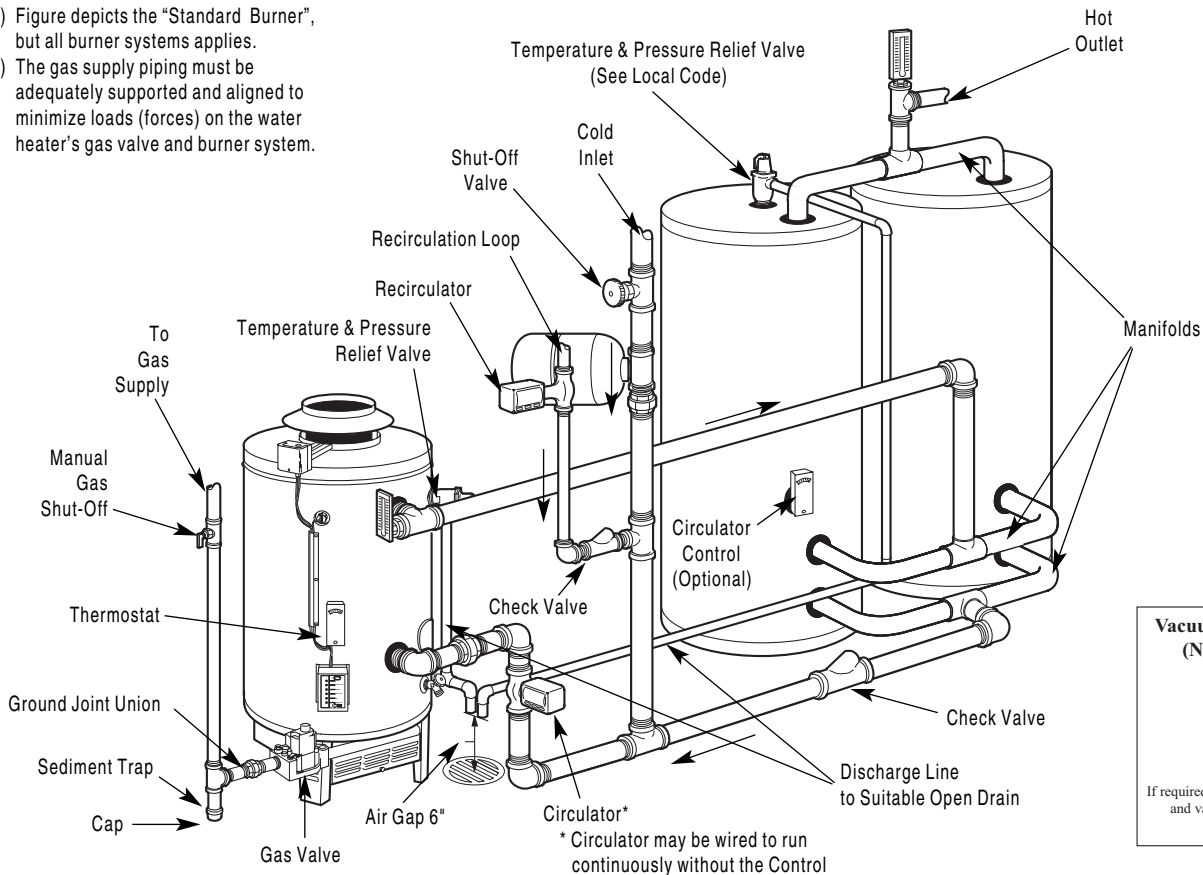

Vacuum Relief Valve (Not Supplied)

If required, install per local codes and valve manufacturer's instructions.

Figure 5. — Typical Forced Circulation Tank System with Factory Supplied Jacketed & Insulated Storage Tanks.

Installation

A sediment trap must be installed at the bottom of the gas line. See Fig. 4 or 5 on page 6.

The pipe compound used should be resistant to the action of liquefied petroleum gases.

LEAK TESTING — The water heater and its gas connections **MUST** be leak tested at normal operating pressure before it is placed in operation. Turn ON the manual gas shut-off valve near the water heater. Use a soapy water solution to test for gas leaks at all connections and fittings. Bubbles indicate a gas leak that must be corrected. The water heater factory connections to the gas valve should also be leak tested after placing the water heater in operation.

WARNING

NEVER use open flame to test for gas leaks, as bodily injury or property damage could result.

PRESSURE TESTING THE GAS SUPPLY SYSTEM — The water heater and its manual gas shut-off valve **MUST** be disconnected from the gas supply piping system during any high pressure testing of that system at pressures in excess of 1/2 psi (14" w.c. / 3.5 kPa).

The water heater **MUST** be isolated from the gas piping system by closing the manual gas shut-off valve during any pressure testing of the gas supply piping at pressures equal to or less than 1/2 psi (14" w.c. / 3.5 kPa).

- 5. RELIEF VALVE** — A new factory installed combination pressure and temperature relief valve, complying with the Standard for Relief Valves and Automatic Gas Shutoff Devices for Hot Water Supply Systems, ANSI Z21.22, or Standard CAN1-4.4, Temperature, Pressure, Temperature and Pressure Relief Valves and Vacuum Relief Valves is provided with the water heater. No valve is to be placed between the relief valve and the water heater. For a circulating tank installation, the separate storage tank(s) must have similar protection. The pressure rating of the relief valve must not exceed 150 psi (160 psi for ASME models), the maximum working pressure as marked on front of the water heater.

The Btu/h rating of the relief valve must equal or exceed the Btu/h input of the water heater as marked on its rating plate.

Connect the outlet of the relief valve to a suitable open drain. The discharge line must pitch downward from the valve to allow complete draining (by gravity) of the relief valve and discharge line, and be no smaller than the outlet of the valve. The end of the discharge line should not be threaded or concealed and should be protected from freezing. No valve of any type, restriction or reducer coupling should be installed in the discharge line. Local codes shall govern the installation of relief valves.

- 6. THERMAL EXPANSION** — Determine if a check valve exists in the inlet water line. It may have been installed in the cold water line as a separate back flow preventer, or it may be part of a pressure reducing valve, water meter or water softener. A check valve located in the cold water inlet line can cause what is referred to as a "closed water system". A cold water inlet line with no check valve or back flow prevention device is referred to as an "open" water system.

As water is heated, it expands in volume and creates an increase in the pressure within the water system. This action is referred to as "thermal expansion". In an "open" water system, expanding water which exceeds the capacity of the water heater flows back into the city main where the pressure is easily dissipated.

A "closed water system", however, prevents the expanding water from flowing back into the main supply line, and the result

of "thermal expansion" can create a rapid, and dangerous pressure increase in the water heater and system piping. This rapid pressure increase can quickly reach the safety setting of the relief valve, causing it to operate during each heating cycle. Thermal expansion, and the resulting rapid, and repeated expansion and contraction of components in the water heater and piping system can cause premature failure of the relief valve, and possibly the heater itself. Replacing the relief valve **will not** correct the problem!

The suggested method of controlling thermal expansion is to install an expansion tank in the cold water line between the water heater and the check valve. The expansion tank is designed with an air cushion built in that compresses as the system pressure increases, thereby relieving the over pressure condition and eliminating the repeated operation of the relief valve. Other methods of controlling thermal expansion are also available. Contact your installing contractor, water supplier, or plumbing inspector for additional information regarding this subject.

If a recirculation line is installed, the return connection should be made to a tee close to the inlet connection on the water heater. A check valve should always be installed in the recirculation line to prevent cold water from entering.

Factory designed Equa-Flow Manifolds, and Jacketed, Insulated Storage Tanks are available.

WATER CONNECTIONS — This water heater may be connected individually, in multiples with others, or with an external hot water storage tank.

Inlet water connections are made to the lower coupling on the heater, and outlet water connections are made to the upper coupling or, if desired on models so equipped, the optional top connections may be utilized.

Cap unused connections. Use only clean, new galvanized steel, copper or approved plastic pipe for water connections. Local codes or regulations shall govern the exact type of material to be used. The installation of unions on the inlet and outlet water lines and a shut-off valve in at least the cold water inlet line is recommended, so the water heater may be easily disconnected for servicing.

When this water heater is supplying general purpose hot water requirements for use by individuals, a thermostatically controlled mixing valve is recommended to reduce the risk of scald injury. Contact a licensed plumber or the local plumbing authority for further information.

Thermometer(s) should be installed so that they indicate the temperature of the water at or near the outlet of the water heater and storage tank(s) if provided. See Fig. 4 or 5 on page 6.

- 7. WIRING** — A polarized 230V 50/60 Hz power supply, with suitable disconnect means, must be connected to the black and white leads provided. The current draw by the Standard Burner Unit is 0.3 Amps, 1.5 Amps on the Power Assist Burner unit, and 2.5 amps on the Xtreme unit. The water heater, when installed, must be electrically grounded in accordance with local codes, or, in the absence of local codes, with the National Electrical Code, ANSI/NFPA 70 in the United States; or CSA C22.1 Electrical Code, in Canada. Refer to Fig. 12, 13, 14, 15, or 16 on pages 24-28 of this manual for water heater internal wiring diagrams.

- 8. Tank Water Supply** — If the water heater is supplied with water from a tank supply and a pressure pump system is not installed (gravity feed), then the bottom of the supply tank must be at least 1 m above the highest point of the hot water plumbing system, including the water heater. Care must be taken to avoid air locks. The cold water line to the water heater should be adequately sized and fitted with a full flow gate valve or ball valve.

Operation

Before operating this water heater, be sure to read and follow the instructions on the label pictured below and all other labels on the water heater, as well as the warnings printed in this manual. Failure to do so can result in unsafe operation of the water heater resulting in property damage, bodily injury, or death. Should you have any problems reading or following the instructions in this manual, STOP, and get help from a qualified person.

Lighting Instructions for the Standard and Power Assist Units Only.

1. LIGHTING PROCEDURE - Lighting procedures are outlined on the label pictured below. This label is also located on the water heater near the thermostat.

NOTE: The Gas Valve supplied with this water heater may vary from the one pictured on the label below, but the Lighting Instructions are the same for all types of valves supplied with this model water heater.

FOR YOUR SAFETY READ BEFORE OPERATING

WARNING: If you do not follow these instructions exactly, a fire or explosion may result causing property damage, personal injury or loss of life

- A. This appliance is equipped with an ignition device which automatically lights the pilot. DO NOT try to light the pilot by hand.
- B. BEFORE OPERATING smell all around the appliance area for gas. Be sure to smell next to the floor because some gas is heavier than air and will settle on the floor.
- WHAT TO DO IF YOU SMELL GAS
- Do not try to light any appliance
 - Do not touch any electrical switch; do not use any phone in your building.
 - Immediately call your gas supplier from a neighbor's phone. Follow the gas supplier's instructions.
 - If you cannot reach your gas supplier, call the fire department.
- C. Use only your hand to turn the gas control knob. Never use tools. If the knob will not turn by hand, don't try to repair it, call a qualified service technician. Force or attempt to repair may result in a fire or explosion.
- D. Do not use this appliance if any part has been under water. Immediately call a qualified service technician to inspect the appliance and to replace any part of the control system and any gas control which has been under water.

OPERATING INSTRUCTIONS

1. STOP! READ THE SAFETY INFORMATION ABOVE ON THIS LABEL.
2. USING A SLOTTED SCREW DRIVER — INSERT INTO TEMPERATURE ADJUSTMENT OPENING. TURN SCREW CLOCKWISE TO THE LOWEST SETTING
3. TURN OFF ALL ELECTRIC POWER TO THE APPLIANCE.
4. THIS APPLIANCE IS EQUIPPED WITH AN IGNITION DEVICE WHICH AUTOMATICALLY LIGHTS THE PILOT. DO NOT TRY TO LIGHT THE PILOT BY HAND.
5. TURN THE "GAS COCK KNOB" CLOCKWISE TO "OFF."
6. WAIT FIVE (5) MINUTES TO CLEAR OUT ANY GAS. IF YOU THEN SMELL GAS, STOP! FOLLOW "B" IN THE SAFETY INFORMATION ABOVE ON THIS LABEL. IF YOU DON'T SMELL GAS, GO TO NEXT STEP.
7. TURN "GAS COCK KNOB" COUNTER-CLOCKWISE TO "ON".
8. TURN ON ALL ELECTRIC POWER TO THE APPLIANCE.
9. SET THERMOSTAT TO DESIRED SETTING
10. IF THE APPLIANCE WILL NOT OPERATE, FOLLOW THE INSTRUCTIONS "TO TURN OFF GAS TO APPLIANCE" AND CALL YOUR SERVICE TECHNICIAN OR GAS SUPPLIER.

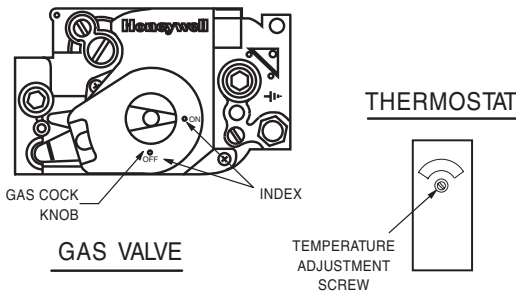

TO TURN OFF GAS TO APPLIANCE

1. SET THE THERMOSTAT TO LOWEST SETTING.
2. TURN OFF ALL ELECTRIC POWER TO THE APPLIANCE IF SERVICE IS TO BE PERFORMED.
3. TURN THE "GAS COCK KNOB" CLOCKWISE TO "OFF".

Operation

Before operating this water heater, be sure to read and follow the instructions on the label pictured below and all other labels on the water heater, as well as the warnings printed in this manual. Failure to do so can result in unsafe operation of the water heater resulting in property damage, bodily injury, or death. Should you have any problems reading or following the instructions in this manual, STOP, and get help from a qualified person.

Lighting Instructions for the Xtreme Unit Only.

1. LIGHTING PROCEDURE - Lighting procedures are outlined on the label pictured below. This label is also located on the water heater near the thermostat.

NOTE: The Gas Valve supplied with this water heater may vary from the one pictured on the label below, but the Lighting Instructions are the same for all types of valves supplied with this model water heater.

NOTE: This unit contains a ceramic burner chamber. When this chamber is heated for the first time the binders will burn off causing a light colored smoke to appear near the bottom of the unit. This generally last for 30 - 45 minutes. This is normal operation and does not indicate a need for alarm or service.

FOR YOUR SAFETY READ BEFORE OPERATING

WARNING If you do not follow these instructions exactly, a fire or explosion may result causing property damage, personal injury or loss of life.

- A. This appliance is equipped with an ignition device which automatically lights the pilot. **DO NOT** try to light the pilot by hand.
 - If you cannot reach your gas supplier, call the fire department.
- B. BEFORE OPERATING smell all around the appliance area for gas. Be sure to smell next to the floor because some gas is heavier than air and will settle on the floor.

WHAT TO DO IF YOU SMELL GAS

 - Do not try to light any appliance
 - Do not touch any electric switch; do not use any phone in your building.
 - Immediately call your gas supplier from a neighbor's phone. Follow the gas supplier's instructions.
- C. Use only your hand to turn the gas control knob. Never use tools. If the knob will not turn by hand, don't try to repair it, call a qualified service technician. Force or attempted repair may result in a fire or explosion.
- D. Do not use this appliance if any part has been under water. Immediately call a qualified service technician to inspect the appliance and to replace any part of the control system and any gas control which has been under water.

OPERATING INSTRUCTIONS

1. STOP! READ THE SAFETY INFORMATION ABOVE ON THIS LABEL.
2. REMOVE OUTER COVER. USING A SLOTTED SCREWDRIVER - INSERT INTO SLOT IN CENTER OF DIAL. TURN DIAL COUNTERCLOCKWISE TO THE LOWEST SETTING.
3. TURN OFF ALL ELECTRIC POWER TO THE APPLIANCE.
4. THIS APPLIANCE IS EQUIPPED WITH AN IGNITION DEVICE WHICH AUTOMATICALLY LIGHTS THE PILOT. **DO NOT** TRY TO LIGHT THE PILOT BY HAND.
5. TURN THE "GAS CONTROL KNOB" CLOCKWISE TO "OFF".
6. WAIT FIVE (5) MINUTES TO CLEAR OUT ANY GAS. IF YOU THEN SMELL GAS, STOP! FOLLOW "B" IN THE SAFETY INFORMATION ABOVE ON THIS LABEL. IF YOU DON'T SMELL GAS, GO TO NEXT STEP.
7. TURN THE "GAS CONTROL KNOB" COUNTERCLOCKWISE TO "ON".
8. TURN ON ALL ELECTRIC POWER TO THE APPLIANCE.
9. SET THERMOSTAT TO DESIRED SETTING. INSTALL OUTER COVER.
10. IF THE APPLIANCE WILL NOT OPERATE, FOLLOW THE INSTRUCTIONS "TO TURN OFF GAS TO APPLIANCE" AND CALL YOUR SERVICE TECHNICIAN OR GAS SUPPLIER.

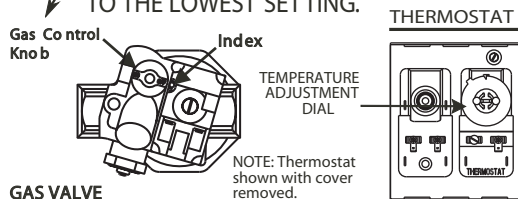

GAS VALVE

NOTE: Thermostat shown with cover removed.

TO TURN OFF GAS TO APPLIANCE

1. SET THE THERMOSTAT TO LOWEST SETTING.
2. TURN OFF ALL ELECTRIC POWER TO THE APPLIANCE IF SERVICE IS TO BE PERFORMED.
3. TURN THE "GAS CONTROL KNOB" CLOCKWISE TO "OFF".

Operation

SAFETY PRECAUTIONS

- A. **Do** turn off manual gas shut-off valve if water heater has been subjected to over heating, fire, flood, physical damage or if gas supply fails to shut off.
- B. **Do Not** turn on water heater unless it is filled with water.
- C. **Do Not** turn on water heater if cold water supply shut-off valve is closed.
- D. **Do Not** store or use gasoline or other flammable vapors and liquids, such as adhesives or paint thinner, in vicinity of this or any other appliance. If such flammables must be used, open doors and windows for ventilation, and all gas burning appliances in vicinity should be shut off, including their pilot lights, to avoid vapors igniting.

NOTE: Flammable vapors may be drawn by air currents from surrounding areas to the water heater.

- E. **Do not** allow combustible materials such as newspaper, rags or mops to accumulate near water heater.
- F. If there is any difficulty in understanding or following the OPERATION or MAINTENANCE instructions, it is recommended that a qualified person or serviceman perform the work.

CAUTION

Hydrogen gas can be produced in a hot water system served by this water heater that has not been used for a long period of time (generally two weeks or more). **HYDROGEN GAS IS EXTREMELY FLAMMABLE!!** To dissipate such gas and to reduce risk of injury, it is recommended that the hot water faucet be opened for several minutes at the kitchen sink before using any electrical appliance connected to the hot water system. If hydrogen is present, there will probably be an unusual sound such as air escaping through the pipe as the water begins to flow. **Do not** smoke or use an open flame near the faucet at the time it is open.

WARNING

When this water heater is supplying general purpose hot water requirements for individuals, a thermostatically controlled mixing valve for reducing point of use water temperature is recommended. Contact a licensed plumber or the local plumbing authority for further information.

Outlet water temperature will vary during normal operating cycles. Reliable temperature readings should be taken shortly after main burner cycles off during a period of little or no use.

2. **TEMPERATURE SETTINGS** — The thermostat is adjusted to its lowest temperature position when shipped from the factory. To meet commercial water use needs, it is adjustable up to 180°F (82°C). However, water temperatures over 125°F (52°C) can cause severe burns instantly or death from scalds. This is the preferred starting point for setting the control for supplying general purpose hot water.

Safety and energy conservation are factors to be considered when setting the water temperature on the thermostat. The most energy efficient operation will result when the temperature setting is the lowest that satisfies the needs consistent with the application.

DANGER

Hotter water increases the Potential for Hot Water SCALDS.

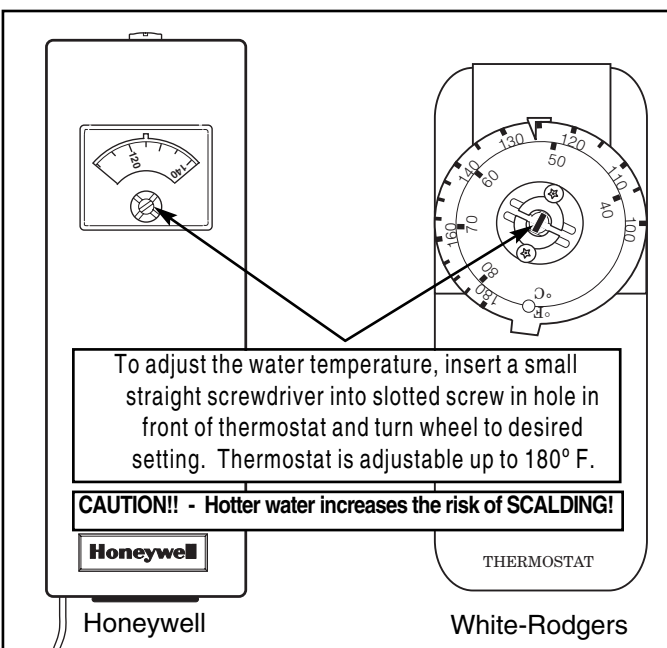

Figure 6. — Thermostat adjustment

3. **GAS MANIFOLD PRESSURE** — With the gas valve supplied with this water heater, main burner ignition occurs at a low or step manifold pressure, which will then automatically build up to its normal operating level. On the Power Assist Burner and Xtreme units, ignition and manifold pressure occur immediately. The rated operating manifold pressure is listed on the water heater rating plate. For purposes of input adjustment, the minimum inlet gas pressure (with main burner on) is also shown on the rating plate. A 1/8" NPT tapping is provided on the outlet side of the gas valve for connecting a manometer to check this pressure. If necessary, adjust the pressure to the proper value by turning regulator adjustment screw clockwise to increase pressure or counterclockwise to decrease pressure.

4. **CHECK INPUT** — Consult the local Gas Company to determine the heating value of the gas supplied. Check input by clocking gas meter with all other gas appliances turned off. Use the following formula:

$$\text{INPUT (btu/h)} = \frac{(3,600) \times (\text{Heating Value}) \times (\text{Number of Cubic Feet Timed})}{\text{Seconds Clocked}}$$

WARNING

DO NOT exceed input shown on the water heater's rating plate!

To insure accuracy for rating, clock enough cubic feet of gas so that the clocked time is at least 60 seconds.

Operation

Small adjustments can be made by varying the manifold pressure from the designated settings mentioned above.

5. INTERMITTENT PILOT FLAME ADJUSTMENT — No adjustment is required with normal inlet gas pressures. The pilot flame adjustment valve is pre-set, and does not normally require re-adjustment.

6. HIGH ALTITUDE — Ratings of gas appliances are based on installation and operation at sea level of elevations of 2000 feet.

Factory prepared high altitude models are available and are specifically rated for installations at elevations up to 5000 feet. Refer to rating plate on front of water heater for model number and altitude specifications.

⚠ WARNING

7. EMERGENCY SHUTDOWN —

Should overheating occur or the gas supply fail to shut off, turn off the manual gas control valve to the appliance.

⚠ WARNING

DO NOT use this appliance if any part has been under water. Immediately call a qualified service technician to inspect the appliance and to replace any part of the control system and any gas control which has been under water.

If the water heater has been subjected to fire or physical damage, turn off gas at the manual gas control (shut-off) valve. Do not operate the water heater again until it has been checked out by a qualified service technician.

Maintenance

Properly maintained, this water heater will provide years of dependable, trouble free service. It is strongly suggested that a regular routine maintenance program be established and followed by the owner. It is further recommended that a periodic inspection of the blower, thermostat, burner, relief valve, internal flueway, draft hood / damper assembly and venting system should be made by service technicians qualified in gas appliance repair.

1. ROUTINE PREVENTIVE MAINTENANCE

A. BURNERS — Visually inspect the main burner flame and the pilot flame at least every three months. Refer to Figures 7, 8, 9, or 10 for normal flame pattern. Fallen scale can usually be dislodged

from the tops of the burners with a thin rod, then vacuumed or brushed from the bottom of the burner box. If a more thorough cleaning is deemed necessary to restore a normal flame pattern, the burner tray assembly should be removed and the burners cleaned individually. (See page 12 for Xtreme models)

⚠ CAUTION

For your safety, removal and cleaning of burner tray and individual burners should be performed ONLY by a qualified service technician, as it involves disconnection of gas piping and leak testing.



Figure 7. — Pilot Flame Pattern (Standard Burner)

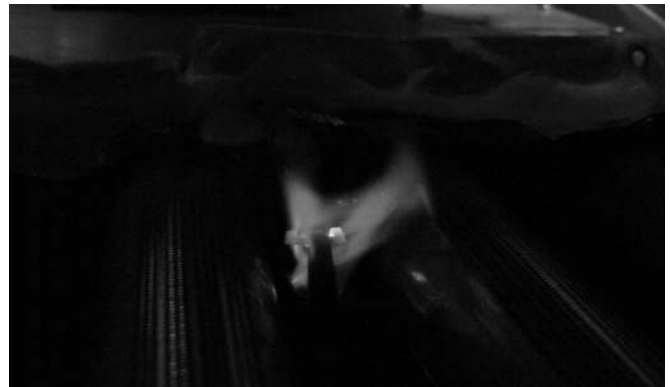

Figure 9. — Pilot Flame Pattern (Power Assist Burner & Xtreme Units)

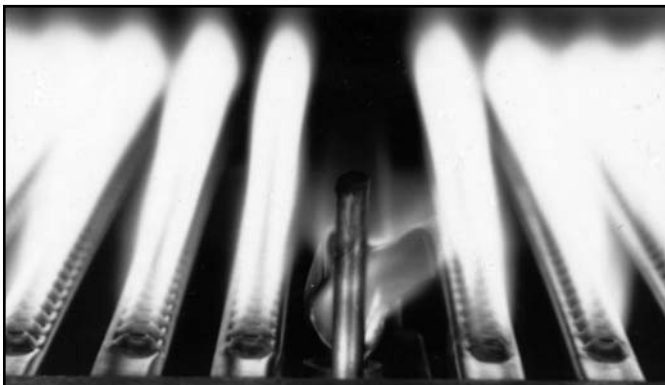

Figure 8. — Pilot & Main Burner Flame Pattern (Standard Burner)

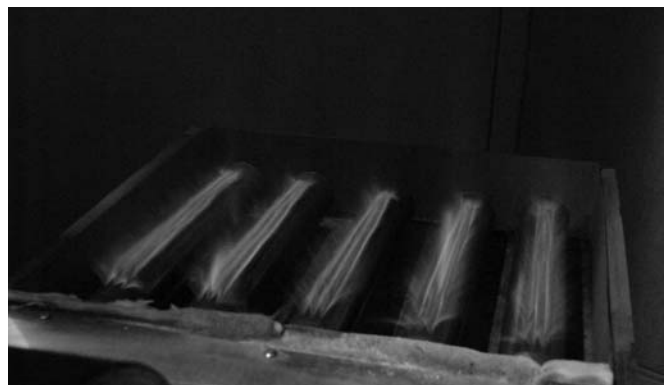

Figure 10. — Pilot & Main Burner Flame Pattern (Power Assist Burner & Xtreme Units)

Maintenance

Burner and pilot assembly removal instructions specific to Xtreme models ONLY!

For instructions on burner removal for standard and power assist models refer to page 13.

To Remove Burner(s):

1. Turn off gas and electric to unit. Remove the two (2) screws that hold the “blower protective cage” over blower. Remove “blower protective cage” and set aside to be reassembled later.
2. Disconnect power cable to blower. Disconnect igniter wire to ignition module and pressure tube from tap on plenum top plate.
3. Remove screws (11) in plenum back plate (See Illustration 1). Remove back plate. Remove screws (8) in plenum top. Remove grommet in plenum top and insert igniter wire through hole. Remove plenum top.
4. Disconnect flexible gas line, at gas inlet. Remove two (2) nuts that hold manifold assembly. Slide manifold out (evenly) and set aside.
5. Remove four (4) screws from burner to be removed. Slide burner out slowly, so that burner chamber refractory is not damaged.
6. Reverse above steps to install new burner. Make sure that all gas connections are tight and all screws are reassembled and tightened (do not over tighten screws).

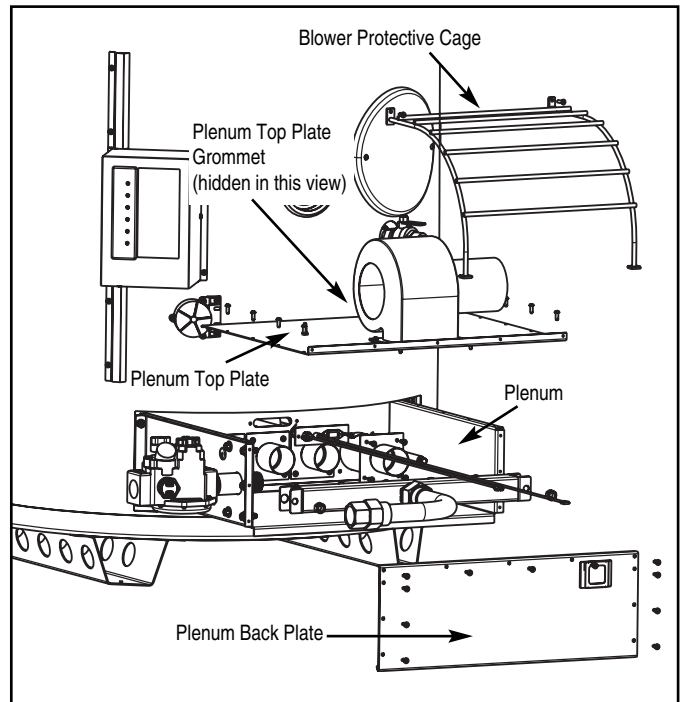

Illustration 1 - Burner Removal (See Illustration 1a for a detailed view of the plenum area.)

To Remove Pilot Assembly:

1. Refer to steps 1 through 4 above.
2. Disconnect pilot tube from gas valve. Remove grommet from side of plenum, where pilot tube enters. Carefully push pilot tube through hole in plenum wall, holding the other end (closest to the pilot) firmly to avoid loosening from pilot.
3. Remove the two (2) screws from pilot assembly. Rotate pilot (down and clockwise, then rock back) assembly to remove from mounting plate.
4. Reverse above steps to install new pilot assembly. Make sure that all gas connections are tight and all screws are reassembled and tightened (do not over tighten screws).

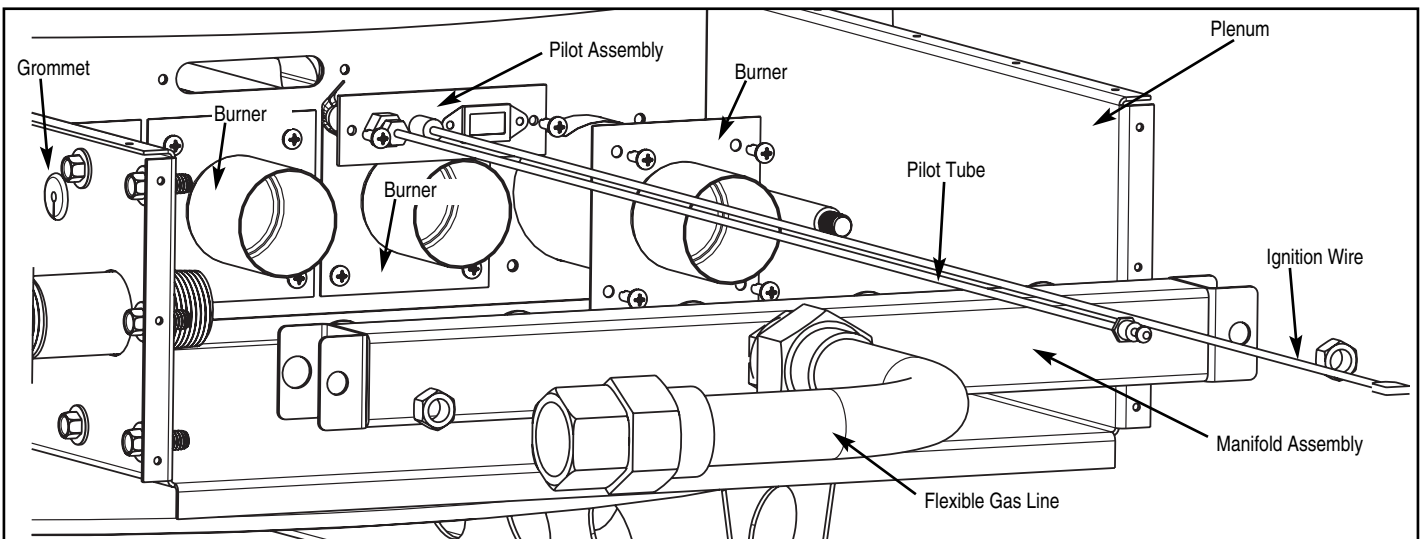

Illustration 1a - Detailed view of plenum area.

Maintenance

TO REMOVE BURNER TRAY:

1. Turn off manual gas shut-off valve.
2. Disconnect gas pipe union and wiring to gas valve, pilot, & blower (If so equipped).
3. Remove retaining screw or bracket from burner tray rail on side opposite gas valve.
4. Slide burner tray assembly out. When reinstalling the burner tray assembly, make certain it is pushed in all the way against the stop attached to the bottom pan. Then reinstall the retaining screw or bracket.
5. Reconnect gas pipe union and wiring to gas valve, pilot, and blower (If so equipped), turn on manual gas shut-off valve and test for gas leak.

B. VENTING SYSTEM — Inspect venting system at least yearly to make certain the passageways are free and unobstructed, and that the vent connectors from the water heater's draft hood to the chimney are properly positioned and securely attached. Remove any obstructions in vent connector or chimney and replace any corroded through vent connectors.

C. CONTROLS — The manifold pressure and controls should be checked at least yearly by a qualified service technician.

D. BLOWER — Clean the blower periodically to remove any buildup of lint or dirt. Remove the inlet plate and blow out any lint or dirt on the wheel and on the screen of the inlet plate. Before operation, re-install the inlet plate to the blower.

E. PRESSURE SWITCH — Inspect the inlet to the pressure switch and the tubing for debris or blockage. Clean out the tubing periodically to prevent buildup of debris.

1. This water heater is equipped with a combination thermostat/temperature limiting device (ECO) that should be checked annually by qualified service personnel.

WARNING

Label all wires prior to disconnection when servicing controls. Wiring errors can cause improper and dangerous operation.

VERIFY PROPER OPERATION AFTER SERVICING!

2. The Temperature and Pressure Relief Valve must be free to operate properly. Check (at least once a year) by lifting the handle fully and allowing several gallons of water to flush through the discharge line. Make certain the discharged water is directed to a suitable drain.

WARNING

Before manually operating the relief valve, make certain no one will be exposed to the danger of coming in contact with the hot water released by this valve. The water may be hot enough to create a SCALD hazard. The water released should be directed to a suitable drain to prevent injury or damage.

NOTE: If the temperature and pressure relief valve on the water heater discharges periodically, this may be due to thermal expansion in a "closed" water system. Contact the water supplier or local plumbing inspector on how to correct this. DO NOT plug the relief valve outlet.

D. TANK— Good maintenance requires that the tank be cleaned of deposits. Unless the water supply is soft (0 to 5 grains hardness), scale or lime deposits will accumulate in the tank. Hard water scale is deposited at an increasingly high rate in proportion to increased water temperature. Accumulation of these deposits may reduce efficiency, and shorten the life of the water heater.

Any new installation should have a tank inspection program set up initially for frequent inspection. The first inspection should be within a six month period. Once the scaling tendencies have been established, the inspection program can be modified to suit the water conditions. Cleaning should be performed if the scale has accumulated above the drain valve opening.

A wet-dry shop vac with a nozzle fashioned from 1" and/or 3/4" polyethylene pipe makes a good tool for scraping and removing scale.

TO CLEAN OR INSPECT TANK:

1. Shut off gas valve and drain tank.
2. Remove tank clean-out cover on jacket and with pocket knife cut and remove a circular plug of insulation the full size of jacket opening.
3. Loosen nut on seal plate assembly enough to twist yoke sideways. Hold assembly securely and push inward, then remove from tank.

- 4. Remove as much built-up scale from flue tubes and tank bottom as practical. Do not attempt to clean so thoroughly that the tool used damages the glass lining.
- 5. Clean the seal plate and install a new gasket. Wipe clean the interior surface of the tank that contacts the gasket. Reinstall the seal plate and tighten in position. Fill tank with water and check for leaks. If no leaks are found, install insulation plug and clean-out cover on jacket and re-light the water heater.

If chemical lime dissolving cleaners are preferred, cautiously follow the instructions supplied with the cleaner. DO NOT use a muriatic or hydrochloric acid (HCl) base cleaner.

2. ANODE INSPECTION — The water supply in certain areas contains very aggressive elements. In these areas, periodic inspection

of the anode is recommended to determine if replacement is necessary. The anode(s) supplied in this water heater is slowly consumed, thereby eliminating or minimizing corrosion and protecting the glass lined tank. The anode(s) should be replaced when more than 6 inches (15 cm) of core wire is exposed at either end.

3. SEASONAL OPERATION — If the water heater is to remain idle for an extended period (60 days or more) the heater should be turned off. The water heater and piping should be drained if they might be subjected to freezing temperatures. It is recommended that the water heater's operation is thoroughly checked (by a qualified service technician) before it is placed back in service. NOTE: Refer to Hydrogen Gas caution notation on page 10.

TABLE 1
Maximum Capacity of Pipe in Cubic Feet of Gas per Hour for Gas Pressures of 0.5 psig or Less and a Pressure Drop of 0.3 Inch Water Column
Based on a 0.60 Specific Gravity Natural Gas; If 1.5 Specific Gravity L.P. Gas is used, multiply capacity by 0.63

Nominal Iron Pipe Size, Inches	Internal Diameter Inches	Length of Pipe, Feet													
		10	20	30	40	50	60	70	80	90	100	125	150	175	200
1/2	.622	132	92	73	63	56	50	46	43	40	38	34	31	28	26
3/4	.824	278	190	152	130	115	105	96	90	84	79	72	64	59	55
1	1.049	520	350	285	245	215	195	180	170	160	150	130	120	110	100
1 1/4	1.380	1,050	730	590	500	440	400	370	350	320	305	275	250	225	210
1 1/2	1.610	1,600	1,100	890	760	670	610	560	530	490	460	410	380	350	320
2	2.067	3,050	2,100	1,650	1,450	1,270	1,150	1,050	990	930	870	780	710	650	610
2 1/2	2.469	4,800	3,300	2,700	2,300	2,000	1,850	1,700	1,600	1,500	1,400	1,250	1,130	1,050	980
3	3.068	8,500	5,900	4,700	4,100	3,600	3,250	3,000	2,800	2,600	2,500	2,200	2,000	1,850	1,700
4	4.026	17,500	12,000	9,700	8,300	7,400	6,800	6,200	5,800	5,400	5,100	4,500	4,100	3,800	3,500

Notes

“System Sentinel” Diagnostic System

The “System Sentinel” Diagnostic system on this water heater provides the user or service technician with a visual representation of the operational status of the various sections of the water heater’s control system. A quick glance at the System Sentinel panel on the front of the heater will give an indication of where to begin trouble shooting of a non operational heater.

The LED’s (light emitting diodes) on the panel are arranged from top to bottom based on their function in the normal sequence of operation, and their function is explained as follows:

POWER

When illuminated, this green LED indicates that 120VAC power is being supplied to the heater, the On/OFF switch is functioning and the 24V transformer is functioning properly.

(Refer to Section 1 of Troubleshooting Guide)

THERMOSTAT

When illuminated, this red LED indicates that the thermostat is functioning (calling for heat) and 24VAC power is being supplied to the Damper Assembly.

(Refer to Section 2 of Troubleshooting Guide)

IGNITION

When illuminated, this red LED indicates that the Damper Assembly is opened. For the standard burner, 24 VAC power is being supplied to the Ignition Control Module, and the ignition sequence has begun. For the Power Assist Burner, 24 VAC power is supplied through the N/C side of the pressure switch actuating the relay and supplying 120 VAC to the blower. After sufficient pressure is reached in the plenum, the N/O side of the pressure switch closes and 24 VAC power is supplied to the Ignition Control Module beginning the ignition sequence.

(Refer to Section 3 of Troubleshooting Guide)

PILOT VALVE

When illuminated, this red LED indicates that the Ignition Control Module is supplying 24 VAC power to the ECO (Energy Cut Off device), or High Limit.

(Refer to Section 4 of Troubleshooting Guide)

ECO

When illuminated, this red LED indicates that the ECO (Energy Cut Off device), or High Limit is closed, and 24 VAC power is being supplied to the PV (Pilot Valve) terminal on the Gas Control Valve.

(Refer to Section 5 of Troubleshooting Guide)

MAIN VALVE

When illuminated, this red LED indicates that the Ignition Control Module is supplying 24 VAC power to the MV (Main Valve) terminal on the Gas Control Valve.

(Refer to Section 6 of Troubleshooting Guide)

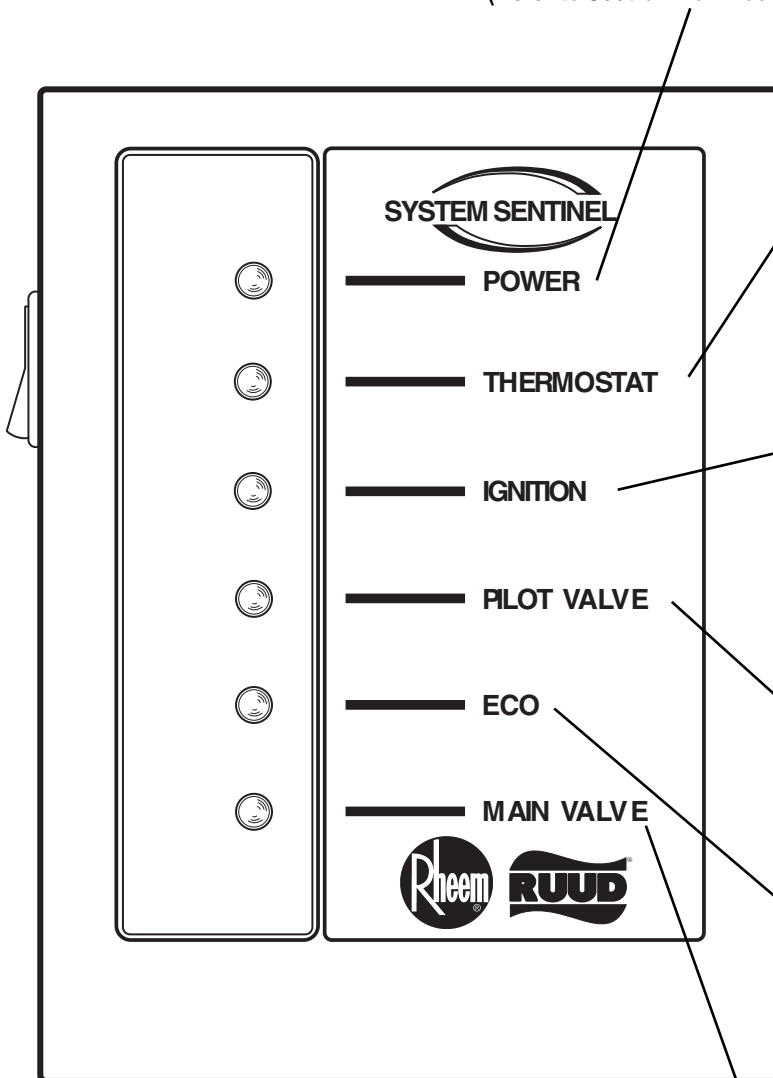

“System Sentinel” Troubleshooting Guide

Section 1... the “POWER” LED

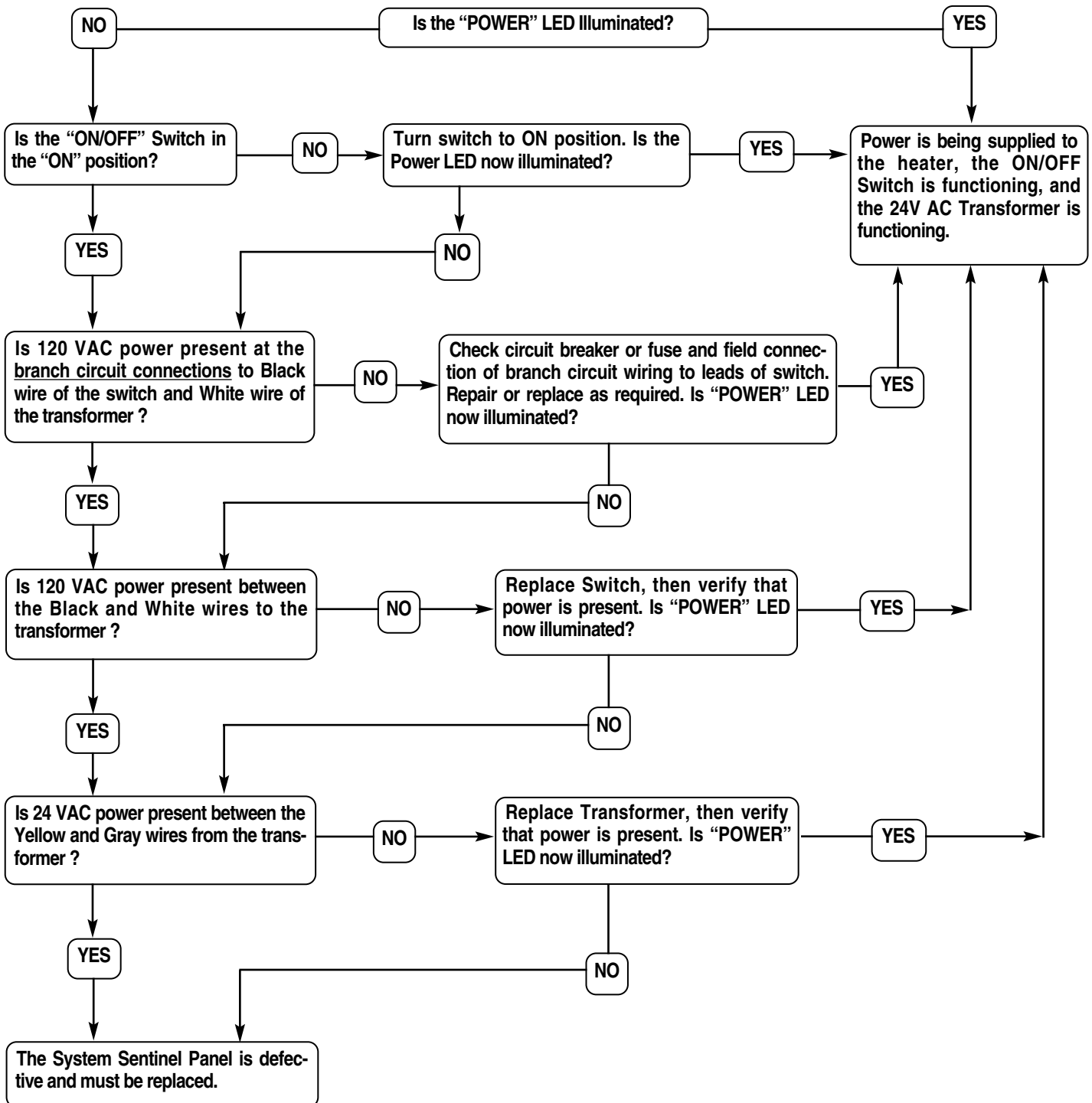

CAUTION

Label all wires prior to disconnection when servicing controls. Wiring errors can cause improper and dangerous operation. VERIFY PROPER OPERATION AFTER SERVICING!

“System Sentinel” Troubleshooting Guide

Section 2... the “THERMOSTAT” LED

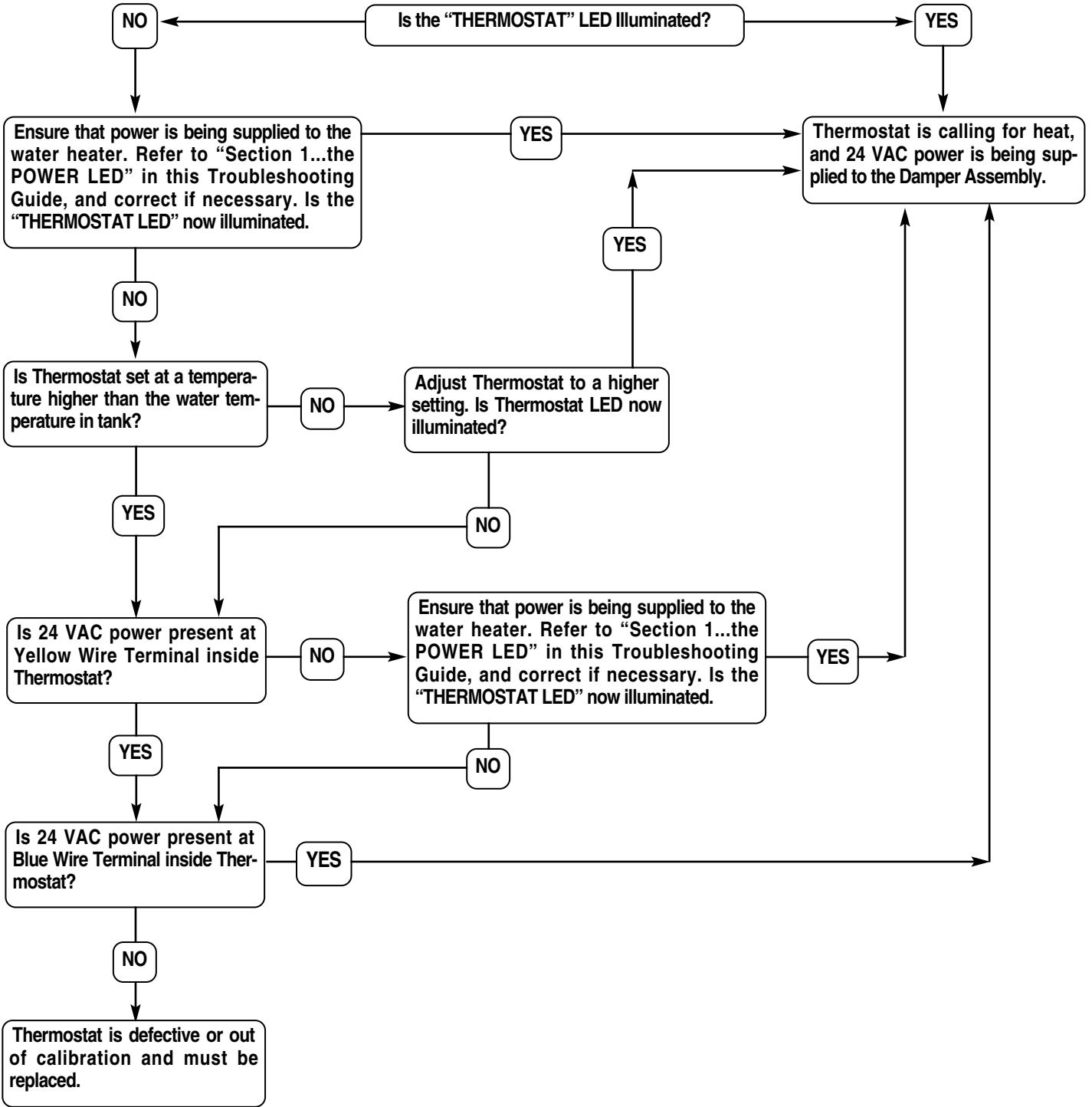

CAUTION

Label all wires prior to disconnection when servicing controls. Wiring errors can cause improper and dangerous operation. VERIFY PROPER OPERATION AFTER SERVICING!

“System Sentinel” Troubleshooting Guide

Section 3... the “IGNITION” LED

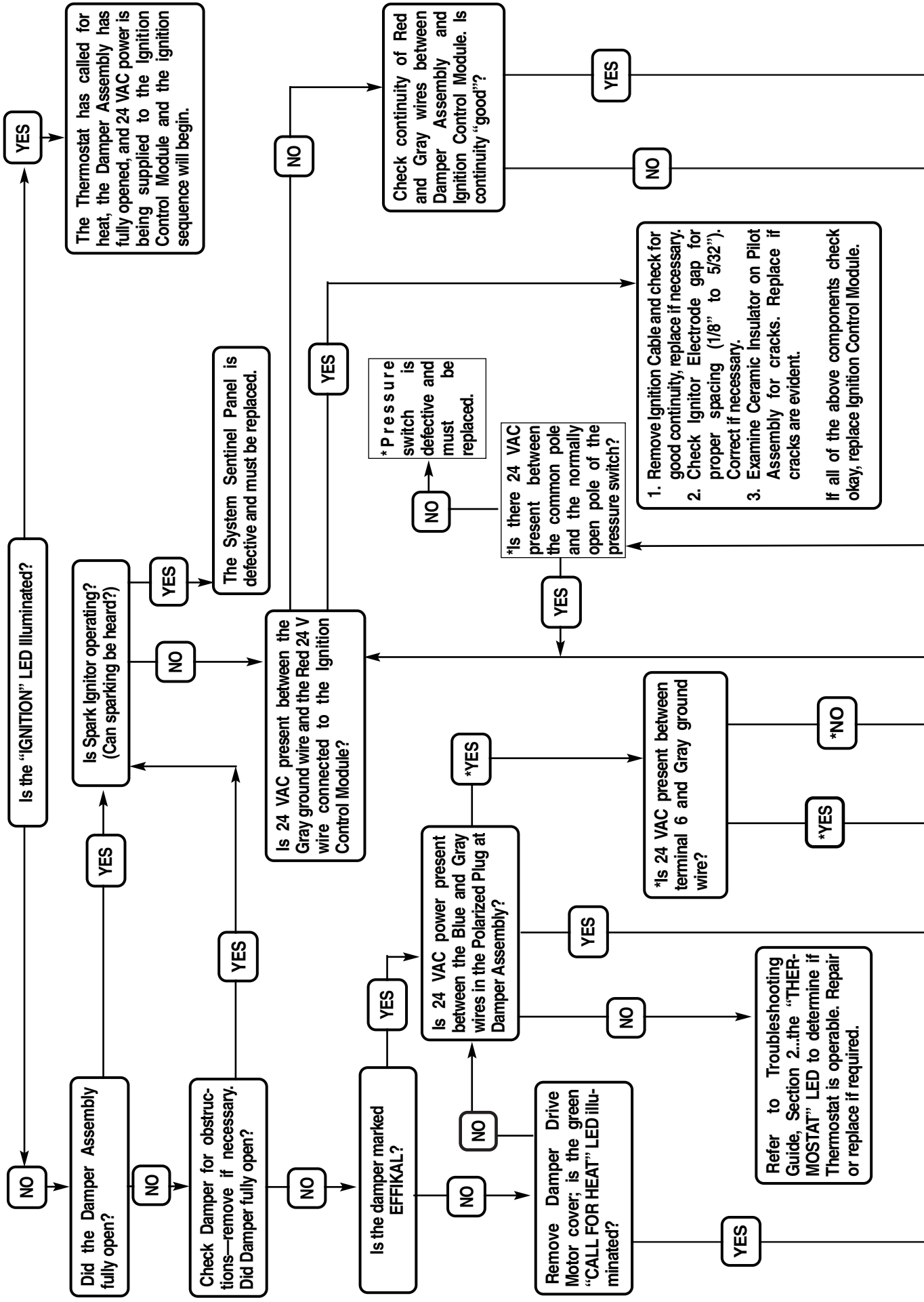

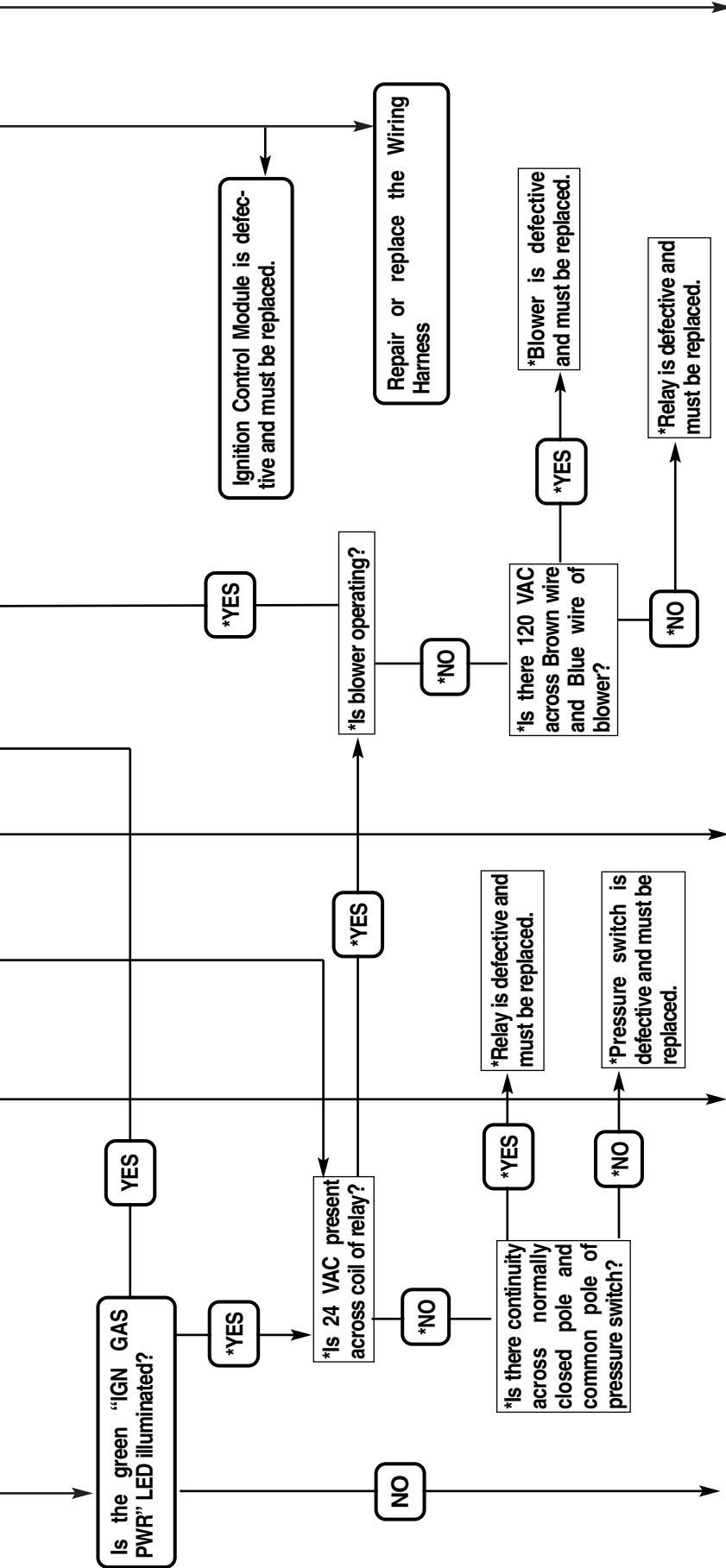

Damper Assembly is defective and must be replaced. The water heater may still be used until a replacement Damper Assembly can be installed by following these steps:

Turn off power to the water heater at the main power switch located on the side of the control enclosure. Order a replacement Damper Assembly.

Honeywell Damper: With power still off, remove Damper Drive Motor cover and move the Service Switch located to the right of the motor from the "NORMAL" position to the "SERVICE" position. Using a standard flat screwdriver, rotate the slotted white knob, located below the motor, counter-clockwise until the damper blade is in the open (fully vertical) position. Replace cover.

Effikal Damper: With power still off, move the Service Switch located on the left side of the control enclosure from the "NORMAL" position to the "SERVICE" position. With pliers secured on the damper shaft near the controller, rotate the damper counter-clockwise until the damper is in the fully open (fully vertical) position.

All Dampers: Turn power on at the main power switch located on the side of the control enclosure. The heater should now attempt its firing sequence.

* Denotes these boxes are for use with the "Power Assist Burner & Xtreme models" only.



Label all wires prior to disconnection when servicing controls. Wiring errors can cause improper and dangerous operation. VERIFY PROPER OPERATION AFTER SERVICING!

“System Sentinel” Troubleshooting Guide

Section 4... the “PILOT VALVE” LED

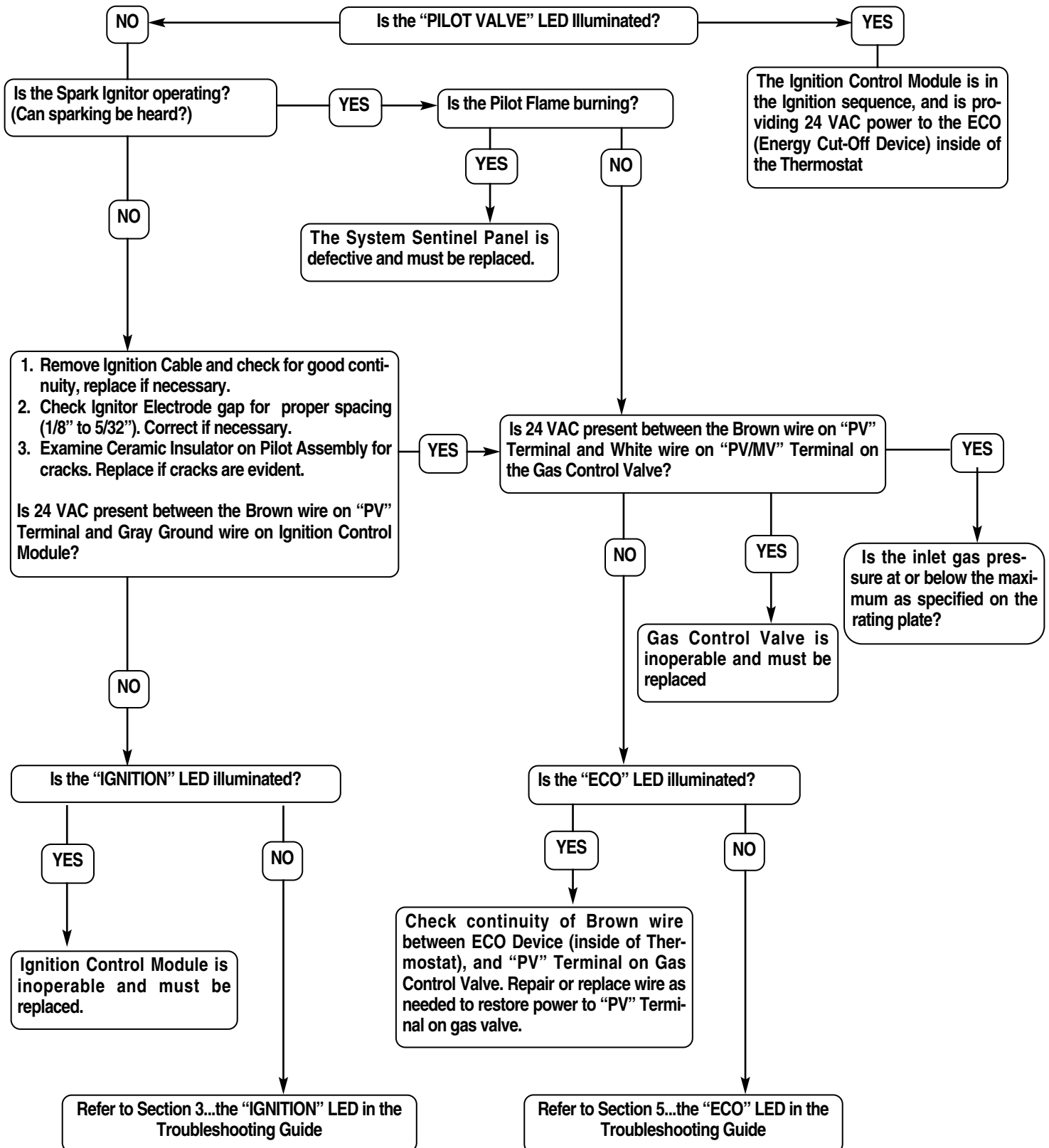

CAUTION

Label all wires prior to disconnection when servicing controls. Wiring errors can cause improper and dangerous operation. **VERIFY PROPER OPERATION AFTER SERVICING!**

“System Sentinel” Troubleshooting Guide

Section 5... the “ECO” LED

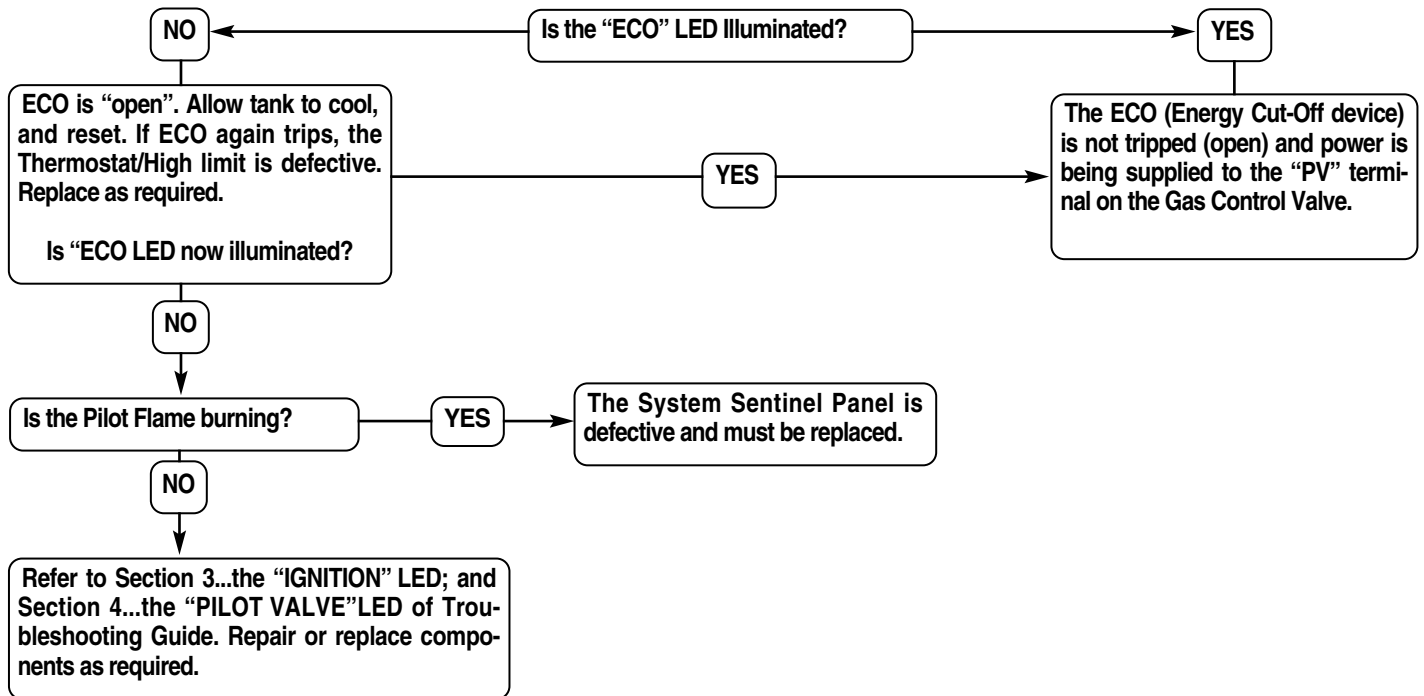

Section 6... the “MAIN VALVE” LED

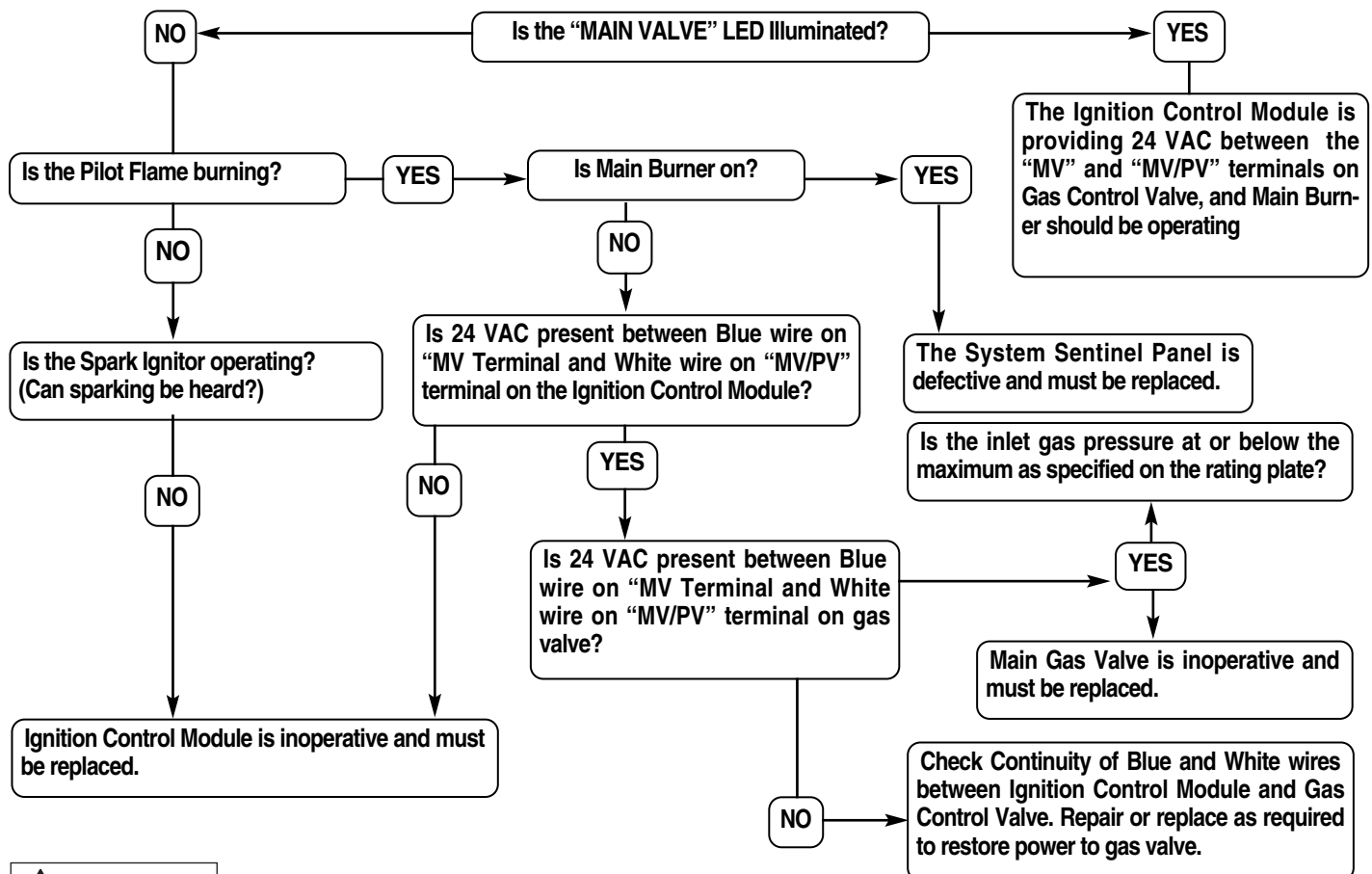

CAUTION

Label all wires prior to disconnection when servicing controls. Wiring errors can cause improper and dangerous operation. VERIFY PROPER OPERATION AFTER SERVICING!

Replacement Parts

The following Gaskets are required for Normal Maintenance for all Models:

SP5886 Tank Handhole Sealplate Gasket

All other Parts can be ordered by providing the following information:

1. Description of Part(s), such as:
Main Gas Valve
Pilot Burner
Main Burner
Thermostat
Damper / Draft Hood Assembly
Anode Rod
Or other parts as required.
2. Quantity of each part required.
3. Complete models number and name of the water heater.
4. Serial Number of water heater.
5. Specify Type of Gas.
6. Address Parts Orders to your distributor or dealer.

Notes

How to Obtain Service Assistance

1. Should you have any questions about your new water heater, or if it requires adjustment, repair, or routine maintenance, it is suggested that you first contact your installer, plumbing contractor or previously agreed upon service agency. In the event that the firm has moved, or is unavailable, refer to the telephone directory commercial listings or local utility for qualified service assistance.

2. Should your problem not be solved to your complete satisfaction, you should then contact the Manufacturer's National Service Department at one of the following address:

In The U.S.A.:
Rheem Manufacturing Co., Water Heater Division
2600 Gunter Park Drive
Montgomery, Alabama 36109-1413
Phone: 1-800-432-8373.

In CANADA:
Rheem Canada, Ltd. / Ltée
P.O. Box 2846
Hamilton, ON L8N 3P3
Phone: 1-800-268-6966.

When contacting the manufacturer, the following information should be made available:

- a. Model and serial numbers of the water heater as shown on the rating plate attached to the jacket of the heater.

- b. Address where water heater is located and can be seen.

- c. Name and address of installer and any service agency who performed service on the water heater.

- d. Date of original installation and dates any service work was performed.

- e. Details of the problem as you can best describe them.

- f. List of people, with dates, who have been contacted regarding your problem.

Notes

Wiring and Schematic Diagrams

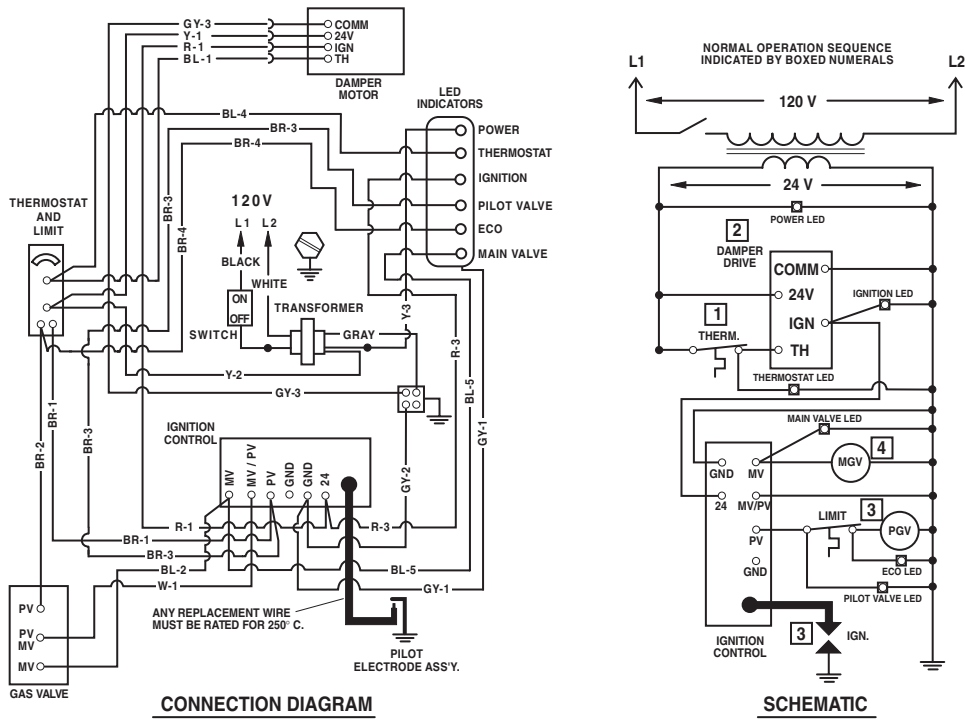

NOTE: If any of the original wire as supplied with this appliance must be replaced, it MUST be replaced with 18 GA., 600V, 105°C wire or its equivalent, unless otherwise noted.



CAUTION! Label all wires prior to disconnection when servicing controls. Wiring errors can cause improper and dangerous operation. VERIFY PROPER OPERATION AFTER SERVICING!

Figure 12. — Diagrams for units supplied with Honeywell VR8304P Gas Valve and Honeywell S8600M Ignition Control.

Wiring and Schematic Diagrams

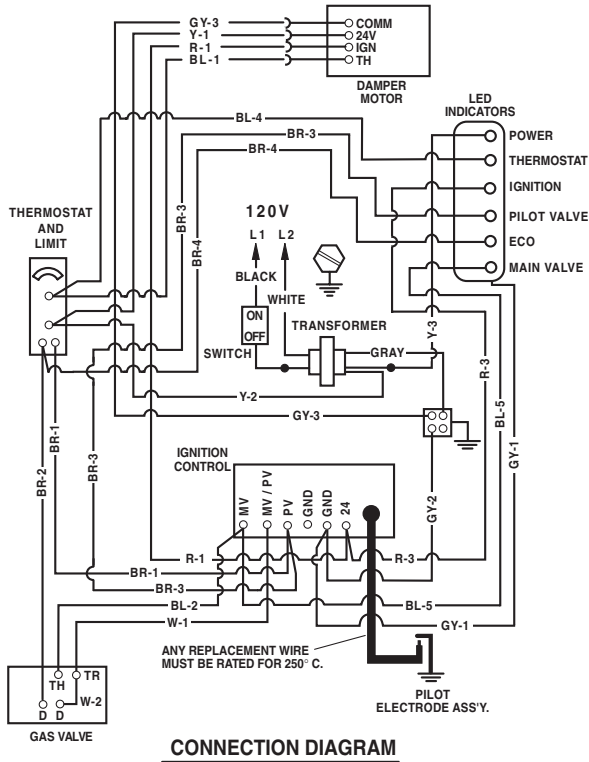

CONNECTION DIAGRAM

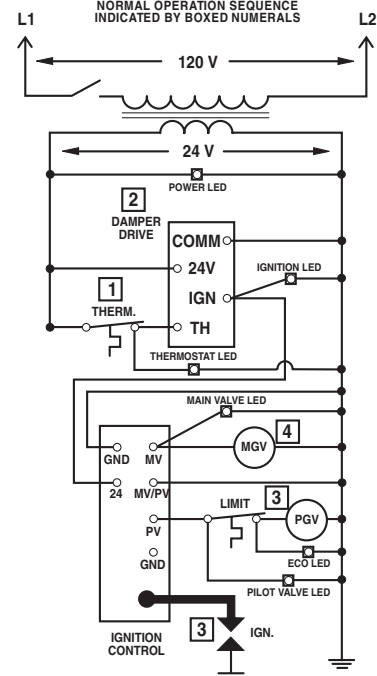

SCHEMATIC

NOTE: If any of the original wire as supplied with this appliance must be replaced, it MUST be replaced with 18 GA., 600V, 105°C wire or its equivalent, unless otherwise noted.

CAUTION! Label all wires prior to disconnection when servicing controls. Wiring errors can cause improper and dangerous operation. VERIFY PROPER OPERATION AFTER SERVICING!

Figure 13. — Diagrams for units supplied with Robertshaw 7000 DERHC-S7C or 7000BDER-S7C Gas Valve and Honeywell S8600M Ignition Control.

Wiring and Schematic Diagrams

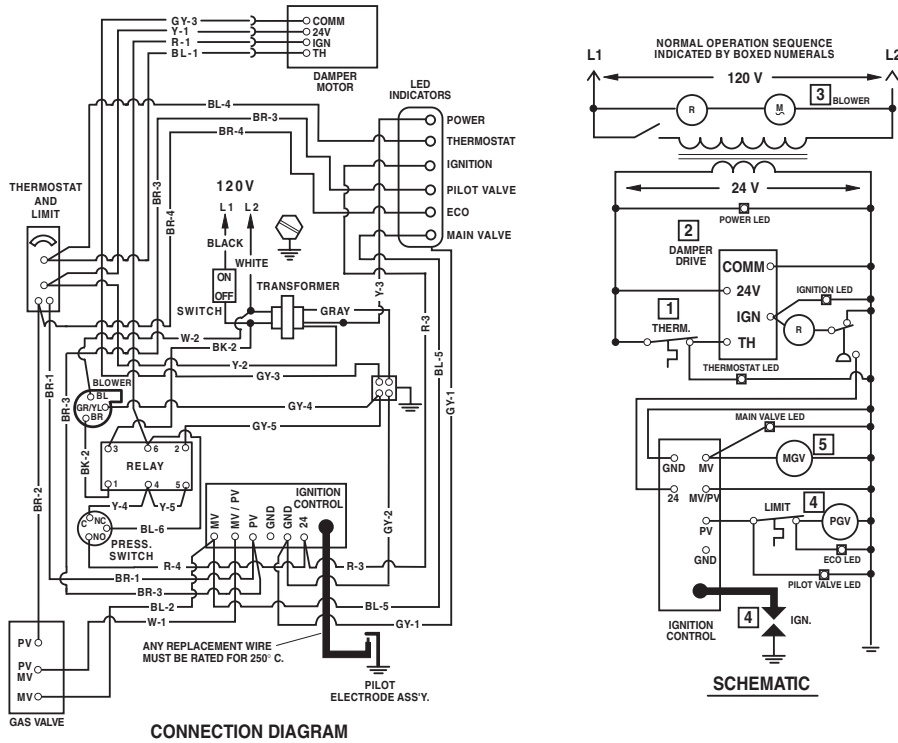

CAUTION! Label all wires prior to disconnection when servicing controls. Wiring errors can cause improper and dangerous operation. VERIFY PROPER OPERATION AFTER SERVICING!

Figure 14. — Diagrams for units supplied with Honeywell VR8304M Gas Valve and Honeywell S8600M Ignition Control.

Wiring and Schematic Diagrams

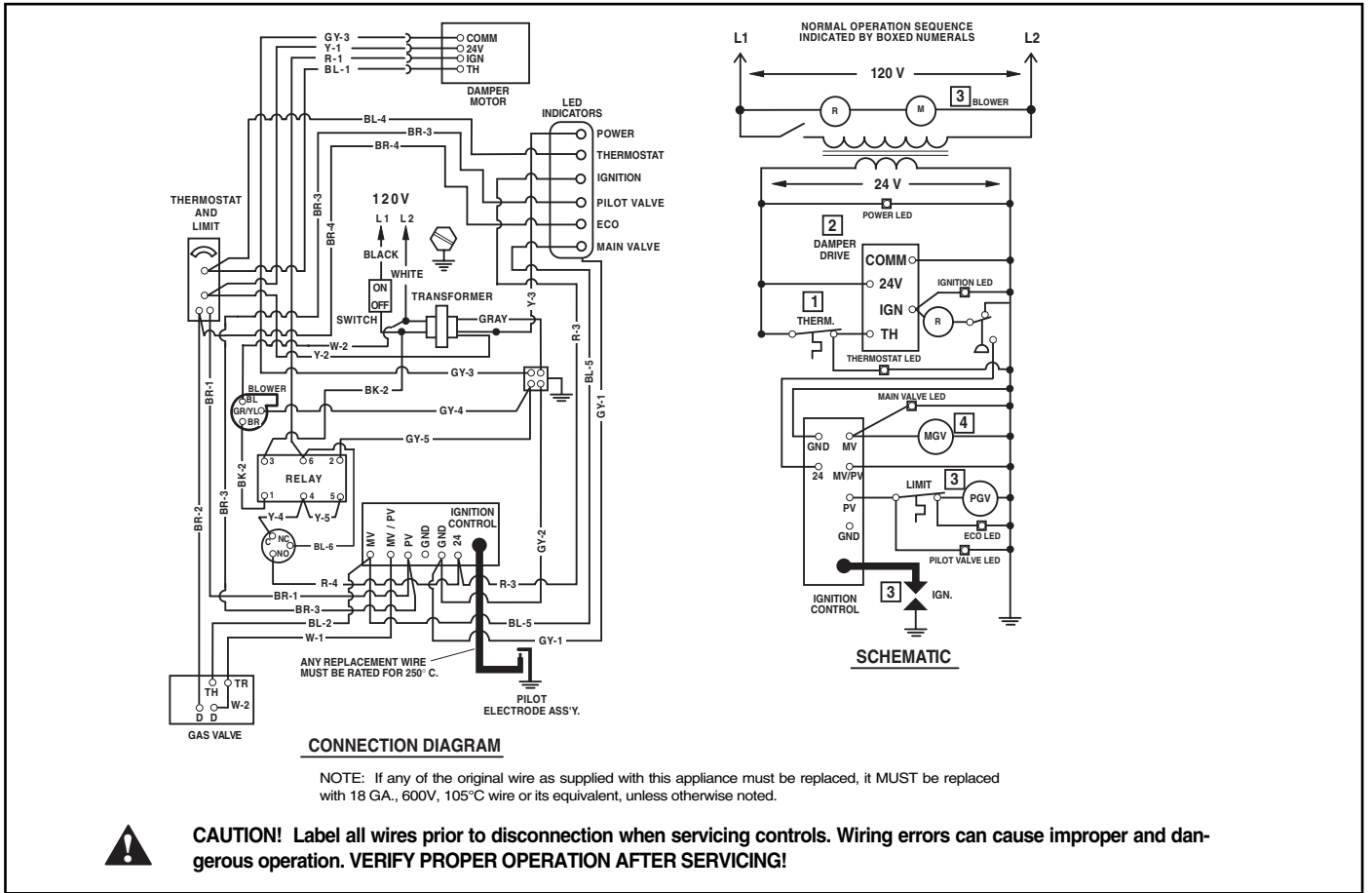

Figure 15. — Diagrams for units supplied with Robertshaw 7000 DERHC-S7C or 7000BDER-S7C Gas Valve and Honeywell S8600M Ignition Control.

Wiring and Schematic Diagrams

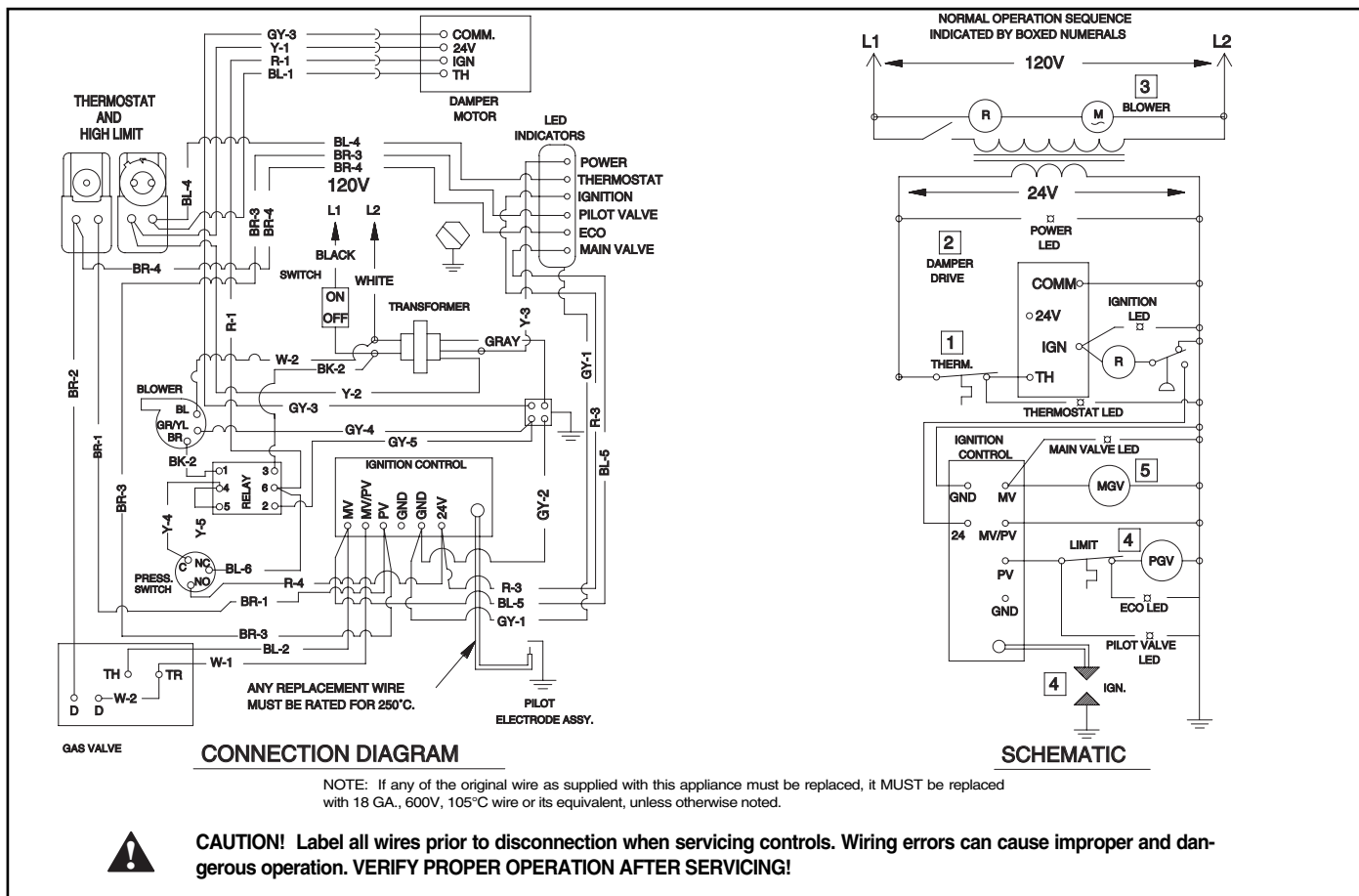

Figure 16. — Diagrams for units supplied with Robertshaw 7000 DERHC Gas Valve and Honeywell S8600M Ignition Control.

⚠ WARNING

This product must be installed by a licensed Plumber or Gas Fitter when installed within The Commonwealth of Massachusetts. When flexible connectors are used, the maximum length shall not exceed 36 inches. When lever type gas shutoffs are used, they shall be T-Handle type.