



Endeavor[®] Line Achiever[®] Series Gas Furnaces



R801T

80% A.F.U.E.†

Heating Stages: Single Stage

Motor Type: Constant Torque

Input Rates: 50-150 kBTU [14.6-44.0 kW]

Configuration Options: Upflow/Horizontal



† A.F.U.E. (Annual Fuel Utilization Efficiency) calculated in accordance with Department of Energy test procedures.

Table of Contents

Features & Benefits	3
Model Number Identification	4
Physical Data and Specifications	5
Dimensional Data	6-7
Blower Performance Data	8
Accessories	9
Limited Warranty	12

Features and Benefits

- **PlusOne® Diagnostics:** Industry-first, 7-segment LED for quick & easy service
- **PlusOne® Ignition System:** Proven Direct Spark Ignition (DSI) for reliability and longevity
- **Low Profile, 34-inch Cabinet:** Makes our furnaces ideal for space-constrained installations
- **Hemmed Cabinet & Door Edges and Quarter-Turn Door Fasteners (Upflow/Horizontal only):** Allows for safe, tool-less access and serviceability
- **Removable Heat Exchanger:** Improves serviceability. Aluminized steel construction provides maximum corrosion resistance and thermal fatigue reliability

Gas Furnaces

<u>R</u>	<u>80</u>	<u>1</u>	<u>T</u>	<u>050</u>	<u>3</u>	<u>A</u>	<u>14</u>	<u>UH</u>	<u>S</u>	<u>N</u>	<u>A</u>	<u>S</u>
Brand	Furnace Efficiency	Stages of Heating	Motor Type	Heating Input	AC Max. Capacity	Major Series	Width	Position	NOx	Controls	Minor Series	Option Code
R - Ruud	80 - 80% AFUE	1 - Single-Stage	T - Constant Torque	050 - 50K BTUH [14.7 kW] 075 - 75K BTUH [22.0 kW] 100 - 100K BTUH [29.3 kW] 125 - 125K BTUH [36.6 kW] 150 - 150K BTUH [44.0 kW]	3 - 3 ton drive 4 - 4 ton drive 5 - 5 ton drive	A - 1st Design Series	14 - 14" Width 17 - 17.5" Width 21 - 21" Width 24 - 24.5" Width	UH - Upflow Horizontal	S - Standard N - Low NOx	N - Non-Comm.	A - 1st Series	S - Standard Grade

[] Designates Metric Conversions

AVAILABLE MODELS
R801T0503A14UH*NAS
R801T0504A17UH*NAS
R801T0754A17UH*NAS
R801T0754A21UH*NAS
R801T1004A17UH*NAS
R801T1005A21UH*NAS
R801T1255A24UH*NAS
R801T1505A24UH*NAS

* S = Standard, N = Low NOx

STANDARD EQUIPMENT
100% Safety Lock Out
29-4C Stainless Steel Secondary Heat Exchanger Design
Adjustable Cool Fan Off Delay
Aluminized steel primary heat exchanger design
Blower Compartment Door Safety Switch
Completely assembled and wired
Direct Drive Motor
Solid State On/Off Blower Time Control
Fully Insulated Heat Exchanger Cabinet
Humidifier Terminal Connection
Induced Draft Motor
Limit Controls
Low Speed Continuous Fan Option
Manual Shut-Off Valve
One Hour Automatic Retry
Power And Self-Test Diagnostics
Pressure Switch
5 Speed Constant Torque Electrically Commutated Blower Motor
Redundant Main Gas Control
Single Stage Heating Thermostat Connection
Blower Insulation
Solid Bottom
Electrical Air Cleaner Terminal

WARNING
 THIS FURNACE IS NOT APPROVED
 OR RECOMMENDED
 FOR USE IN MOBILE HOMES

Physical Data and Specifications—Upflow Models

MODEL NUMBERS R801T Constant Tq-UH Series	R801T0503 A14UH*NAS	R801T0504 A17UH*NAS	R801T0754 A17UH*NAS	R801T0754 A21UH*NAS	R801T1004 A17UH*NAS	R801T1005 A21UH*NAS	R801T1255 A24UH*NAS	R801T1505 A24UH*NAS
Input-BTU/Hr [kW]	50,000 [15]	50,000 [15]	75,000 [22]	75,000 [22]	100,000 [29]	100,000 [29]	125,000 [37]	150,000 [44]
Heating Capacity BTU/Hr [kW] ①	40,000 [12]	40,000 [12]	60,000 [18]	60,000 [18]	80,000 [23]	80,000 [23]	100,000 [29]	120,000 [35]
Blower (D x W) [mm]	11 x 6 [279 x 152]	11 x 7 [279 x 178]	11 x 7 [279 x 178]	11 x 7 [279 x 178]	11 x 7 [279 x 178]	11 x 10 [279 x 254]	11 x 10 [279 x 254]	11 x 10 [279 x 254]
Motor H.P. [W] Type	1/2 [373] 5 Spd Constant Torque	3/4 [560] 5 Spd Constant Torque	1/2 [373] 5 Spd Constant Torque	3/4 [560] 5 Spd Constant Torque	3/4 [560] 5 Spd Constant Torque	3/4 [560] 5 Spd Constant Torque	3/4 [560] 5 Spd Constant Torque	3/4 [560] 5 Spd Constant Torque
Min. Circuit Ampacity	8	11	9	9	9	10	10	10
Min. Overload Protection Device	15	15	15	15	15	15	15	15
Max. Overload Protection Device	15	15	15	15	15	15	15	15
Motor Full Load Amps	6.1	9.6	6.1	9.6	9.6	9.6	9.6	9.6
Heating Speed	Med	Med-Low	Med	Med-High	Med-High	Med	Med-High	Med-High
Cooling Speed	High	High	High	High	High	High	High	High
Cooling CFM @ Rating Point [L/s]	1305 [616]	1450 [684]	1402 [662]	1608 [759]	1402 [662]	1840 [868]	1934 [913]	1934 [913]
Max. E.S.P. (In. W.C.) [kPa]	.9 [0.224]	.9 [0.224]	.9 [0.224]	.9 [0.224]	.9 [0.224]	.9 [0.224]	.9 [0.224]	.9 [0.224]
Temperature Rise Range °F [°C]	25-55 [13.9-30.6]	25-55 [13.9-30.6]	25-55 [13.9-30.6]	25-55 [13.9-30.6]	40-70 [22-39]	40-70 [22-39]	35-65 [19.4-36.1]	45-75 [25-42]
Approx. Shipping Weight (Lbs.) [kg]	104.5 [47]	110 [50]	117.5 [53]	135 [61]	131.5 [60]	140 [64]	143.5 [65]	155.5 [71]
AFUE ②	80.0%	80.0%	80.0%	80.0%	80.0%	80.0%	80.0%	80.0%

NOTES: All models are 115V, 60HZ, 1 Ph. Gas connection size for all models is 1/2" [13 mm] N.P.T.

① In accordance with D.O.E. test procedures.

② See Conversion Kit Index Form for high altitude derate.

*4 075k 17.5" is wired for 3 tons AC.

*S=Standard, N=Low NOx

This furnace does not meet air district requirements of 14 ng/J NOx emissions limit, and thus is subject to a mitigation fee of up to \$450.

This furnace is to be installed for propane firing only in air districts requiring 14 ng/J NOx emission limits. Operating in natural gas mode is in violation of these Rules.

[] Designates Metric Conversions

Upflow Application

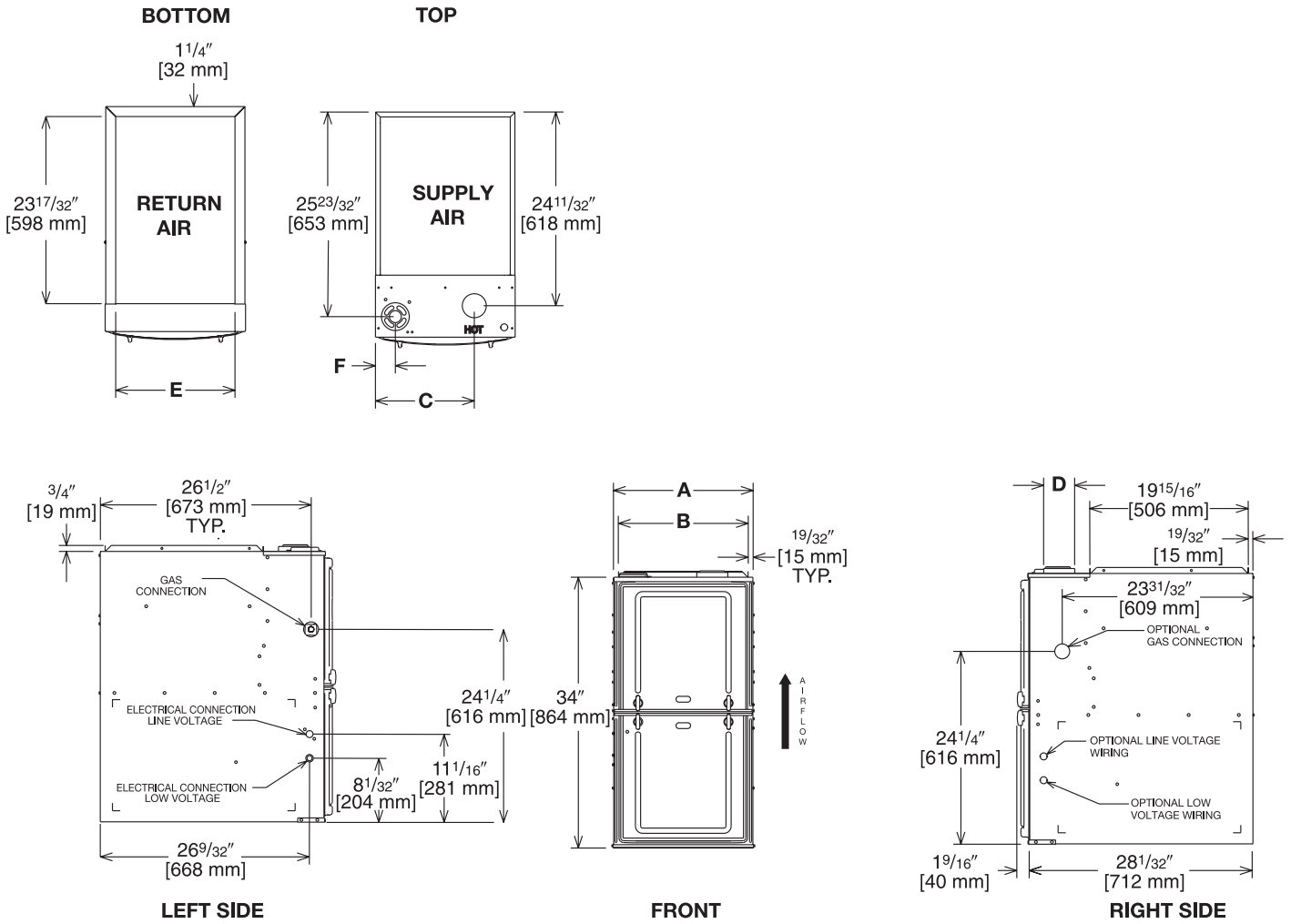

Illustration
ST-A1220-04-00
FIGURE 1

Dimensional Data: Upflow Model

MODEL R801T-	A	B	C	D	E	F	MINIMUM CLEARANCE (IN.) [mm]					
							LEFT SIDE	RIGHT SIDE	BACK	TOP	FRONT	VENT
0503A14	14 [356]	12 27/32 [326]	10 5/8 [270]	①	11 1/2 [292]	1 7/8 [48]	0	4 [102] ②	0	1 [25]	3 [76]	6 [152] ③
0504A17/ 0754A17/1004A17	17 1/2 [445]	16 11/32 [415]	12 3/8 [314]	①	15 [381]	2 1/2 [64]	0	3 [76] ②	0	1 [25]	3 [76]	6 [152] ③
0754A21/1005A21	21 [533]	19 27/32 [504]	14 1/8 [359]	①	18 1/2 [470]	2 1/2 [64]	0	0	0	1 [25]	3 [76]	6 [152] ③
125	24 1/2 [622]	23 11/32 [593]	15 7/8 [403]	①	22 [559]	2 1/2 [64]	0	0	0	1 [25]	3 [76]	6 [152] ③
150	24 1/2 [622]	23 11/32 [593]	15 7/8 [403]	①	22 [559]	2 1/2 [64]	0	0	0	1 [25]	3 [76]	6 [152] ③

NOTES: ① May require a 3" [76 mm] to 4" [102 mm] or 3" [76 mm] to 5" [127 mm] adapter.

② May be 0" [0 mm] with type B vent.

③ May be 1" [25 mm] with type B vent.

Furnaces must be vented in accordance with the National Fuel Gas Code, ANSI Z223.1 and in accordance with local codes.

[] Designates Metric Conversions

Horizontal Application

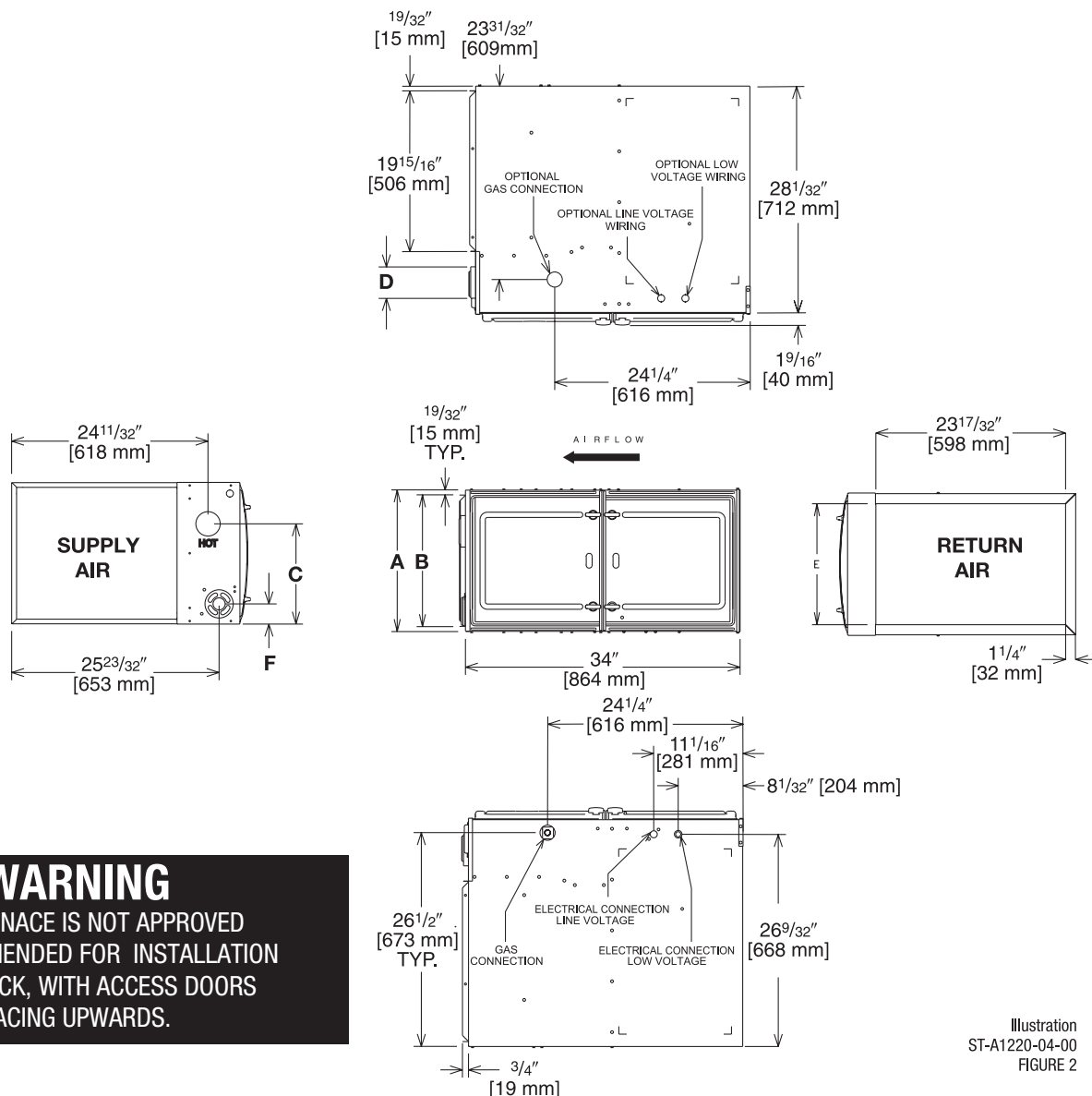

WARNING
THIS FURNACE IS NOT APPROVED
OR RECOMMENDED FOR INSTALLATION
ON ITS BACK, WITH ACCESS DOORS
FACING UPWARDS.

Illustration
ST-A1220-04-00
FIGURE 2

Dimensional Data: Horizontal Model

MODEL R801T-	A	B	C	D	E	F	MINIMUM CLEARANCE (IN.) [mm]					
							SUPPLY AIR SIDE	RETURN AIR SIDE	BACK	TOP	FRONT	VENT
0503A14	14 [356]	12 ²⁷ / ₃₂ [326]	10 ⁵ / ₈ [270]	①	11 ¹ / ₂ [292]	1 ⁷ / ₈ [48]	4 [102] ②	4 [102] ②	0	1 [25]	3 [76]	6 [152] ③
0504A17/ 0754A17/1004A17	17 ¹ / ₂ [445]	16 ¹¹ / ₃₂ [415]	12 ³ / ₈ [314]	①	15 [381]	2 ¹ / ₂ [64]	3 [76] ②	3 [76] ②	0	1 [25]	3 [76]	6 [152] ③
0755A21/1005A21	21 [533]	19 ²⁷ / ₃₂ [504]	14 ¹ / ₈ [359]	①	18 ¹ / ₂ [470]	2 ¹ / ₂ [64]	0	0	0	1 [25]	3 [76]	6 [152] ③
125	24 ¹ / ₂ [622]	23 ¹¹ / ₃₂ [593]	15 ⁷ / ₈ [403]	①	22 [559]	2 ¹ / ₂ [64]	0	0	0	1 [25]	3 [76]	6 [152] ③
150	24 ¹ / ₂ [622]	23 ¹¹ / ₃₂ [593]	15 ⁷ / ₈ [403]	①	22 [559]	2 ¹ / ₂ [64]	0	0	0	1 [25]	3 [76]	6 [152] ③

NOTES: ① May require a 3" [76 mm] to 4" [102 mm] or 3" [76 mm] to 5" [127 mm] adapter.

② May be 0" [0 mm] with type B vent.

③ May be 1" [25 mm] with type B vent.

Furnaces must be vented in accordance with the National Fuel Gas Code, ANSI Z223.1 and in accordance with local codes.

[] Designates Metric Conversions

Blower Performance Data

AIR FLOW PERFORMANCE - 80% SINGLE STAGE UPFLOW/HORIZONTAL CONSTANT TORQUE												
INPUT [BTU] CABINET WIDTH [IN]	AIRFLOW CONTROL SETTINGS	SPEED TAP/ WIRE COLORS	CFM [L/s] AIR DELIVERY EXTERNAL STATIC PRESSURE INCHES WATER COLUMN [KPA]									
			0.1 [0.02]	0.2 [0.05]	0.3 [0.07]	0.4 [0.10]	0.5 [0.12]	0.6 [0.15]	0.7 [0.17]	0.8 [0.19]	0.9 [0.22]	1.0 [0.25]
50K 14"	Factory Setting Fan	Low/Red	915	777	674	598	541	498	460	419	370	304
	Cool	Medium Low/Yellow	963	894	834	781	733	689	646	602	555	504
	Heat or Heat/Cool	Medium/Purple	997	976	947	911	870	825	779	732	687	646
	Cool	Medium High/Blue	1123	1130	1121	1101	1071	1036	997	957	920	888
	Factory Setting Cooling	High/Black	1246	1244	1232	1211	1185	1154	1121	1087	1054	1024
50K 17"	Factory Setting Fan	Low/Red	856	793	733	661	604	543	495	443	397	363
	Heat or Heat/Cool	Medium Low/Yellow	1019	971	921	848	812	756	697	659	593	549
	Cool	Medium/Purple	1131	1080	1035	984	951	881	845	792	741	699
	Cool	Medium High/Blue	1312	1279	1232	1191	1149	1087	1041	1013	973	933
	Factory Setting Cooling	High/Black	1643	1608	1571	1525	1500	1470	1437	1409	1360	1351
75K 17"	Factory Setting Fan	Low/Red	832	796	725	663	580	505	449	405	374	319
	Cool	Medium Low/Yellow	978	975	905	857	799	722	666	600	548	516
	Heat or Heat/Cool	Medium/Purple	1240	1215	1167	1144	1091	1039	997	951	898	842
	Cool	Medium High/Blue	1363	1284	1246	1256	1211	1157	1114	1071	1024	974
	Factory Setting Cooling	High/Black	1776	1716	1655	1637	1609	1604	1591	1554	1520	1476
75K 21"	Factory Setting Fan	Low/Red	1216	1174	1132	1088	1043	998	952	905	858	811
	Cool	Medium Low/Yellow	1314	1271	1229	1188	1147	1105	1063	1019	974	926
	Cool	Medium/Purple	1354	1312	1269	1229	1190	1150	1109	1066	1021	973
	Heat or Heat/Cool	Medium High/Blue	1397	1351	1308	1266	1225	1184	1144	1105	1065	1024
	Factory Setting Cooling	High/Black	1686	1659	1628	1595	1559	1524	1489	1455	1426	1400
100K 17"	Factory Setting Fan	Low/Red	1057	1018	966	903	851	793	737	676	618	566
	Cool	Medium Low/Yellow	1159	1105	1061	1010	956	913	855	792	740	697
	Cool	Medium/Purple	1229	1201	1159	1101	1053	1003	953	897	850	804
	Heat or Heat/Cool	Medium High/Blue	1368	1358	1310	1270	1225	1180	1134	1086	1044	998
	Factory Setting Cooling	High/Black	1574	1532	1493	1455	1414	1379	1341	1309	1274	1236
100K 21"	Factory Setting Fan	Low/Red	1277	1211	1165	1103	1035	967	861	800	740	692
	Cool	Medium Low/Yellow	1556	1498	1456	1409	1353	1308	1254	1198	1125	1083
	Heat or Heat/Cool	Medium/Purple	1644	1597	1554	1511	1463	1400	1358	1304	1253	1192
	Cool	Medium High/Blue	1879	1842	1785	1729	1692	1674	1621	1579	1537	1501
	Factory Setting Cooling	High/Black	2071	2025	1992	1948	1902	1872	1840	1795	1750	1713
125K 24"	Factory Setting Fan	Low/Red	1261	1214	1122	1040	967	897	827	752	688	616
	Cool	Medium Low/Yellow	1670	1611	1555	1503	1428	1369	1316	1259	1203	1148
	Cool	Medium/Purple	1811	1758	1699	1646	1589	1534	1483	1428	1378	1349
	Heat or Heat/Cool	Medium High/Blue	1889	1831	1779	1722	1673	1616	1577	1527	1472	1425
	Factory Setting Cooling	High/Black	1967	1917	1862	1805	1745	1680	1642	1594	1552	1502
150K 24"	Factory Setting Fan	Low/Red	1367	1298	1242	1178	1110	1054	992	907	846	780
	Cool	Medium Low/Yellow	1712	1643	1613	1531	1483	1412	1371	1312	1256	1186
	Cool	Medium/Purple	1882	1810	1778	1697	1642	1589	1571	1489	1426	1387
	Heat or Heat/Cool	Medium High/Blue	1961	1923	1854	1786	1750	1670	1612	1591	1533	1477
	Factory Setting Cooling	High/Black	2001	1945	1892	1845	1782	1736	1700	1649	1601	1562

**BOTTOM RETURN FILTER RACK FOR
UPFLOW APPLICATION: RXGF-CB**

SIDE RETURN FILTER RACK: RXGF-CD

FILTER RACK FILTER SIZES* INCHES [mm]		
MODEL	RXGF-CB (UPFLOW/ HORIZONTAL)	RXGF-CD (UPFLOW) SIDE RETURN
(-)801T0503A14	12 ¹ / ₄ x 25 [311 x 635]	15 ³ / ₄ x 25 [400 x 635]
(-)801T0504A17/ (-)801T0754A17/ (-)801T1004A17	15 ³ / ₄ x 25 [400 x 635]	15 ³ / ₄ x 25 [400 x 635]
(-)801T0755A21/ (-)801T1005A21	19 ¹ / ₄ x 25 [489 x 635]	15 ³ / ₄ x 25 [400 x 635]
(-)801T1255A24/ (-)801T1505A24	22 ³ / ₄ x 25 [578 x 635]	15 ³ / ₄ x 25 [400 x 635]

4" FLUE ADAPTER: RXGW-C01

Indoor Coil Casings

MODEL NUMBER
RXBC-D14AI
RXBC-D17AI
RXBC-D21AI
RXBC-D21BI
RXBC-D24AI

WARNING: IMPORTANT NOTICE

A SOLID METAL BASE PLATE (SEE TABLE) MUST BE IN PLACE WHEN THE FURNACE IS INSTALLED WITH SIDE AIR RETURN DUCTS. FAILURE TO INSTALL A BASE PLATE COULD CAUSE PRODUCTS OF COMBUSTION TO BE CIRCULATED INTO THE LIVING SPACE AND CREATE POTENTIALLY HAZARDOUS CONDITIONS.

FURNACE WIDTH IN. [mm]	SOLID BOTTOM KIT NO.	BASE PLATE NO.	BASE PLATE SIZE IN. [mm]
14 [356]	RXGB-D14	AE-61874-01	11 ⁵ / ₈ x 23 ⁹ / ₁₆ [295 x 598]
17 ¹ / ₂ [445]	RXGB-D17	AE-61874-02	15 ¹ / ₈ x 23 ⁹ / ₁₆ [384 x 598]
21 [533]	RXGB-D21	AE-61874-03	18 ⁵ / ₈ x 23 ⁹ / ₁₆ [473 x 598]
24 ¹ / ₂ [622]	RXGB-D24	AE-61874-04	25 ⁵ / ₈ x 23 ⁹ / ₁₆ [651 x 598]

For High Altitudes

OPTION CODE FOR HIGH ALTITUDE: U.S.

None required for high altitudes.

HIGH ALTITUDE CONVERSION KITS: U.S.

None required for high altitudes.

80+ HIGH ALTITUDE INSTRUCTIONS

CAUTION: Always follow National Fuel Gas Code (NFGC) guidelines when converting for high altitudes.

High altitude option codes are not required for these models. However, the burner orifice size needs to be recalculated and verified at elevations above 2000 ft. See Installation Instructions for more information.

L.P. CONVERSION KIT: RXGJ-FP15

[] Designates Metric Conversions



GENERAL TERMS OF LIMITED WARRANTY*

Ruud will furnish a replacement for any part of this product which fails in normal use and service within the applicable period stated, in accordance with the terms of the limited warranty.

***For complete details of the Limited and Conditional Warranties, including applicable terms and conditions, contact your local contractor or the Manufacturer for a copy of the product warranty certificate.**

Conditional Parts
(Registration Required) Ten (10) Years
Heat Exchanger Twenty (20) Years

Before proceeding with installation, refer to installation instructions packaged with each model, as well as complying with all Federal, State, Provincial, and Local codes, regulations, and practices.

© 2024 Rheem Manufacturing Company. Ruud trademarks owned by Rheem Manufacturing Company.

In keeping with its policy of continuous progress and product improvement, Ruud reserves the right to make changes without notice.

5600 Old Greenwood Road
Fort Smith, Arkansas 72908 • www.ruud.com