



The new degree of comfort.®

PROJECT NAME \_\_\_\_\_

LOCATION \_\_\_\_\_

ARCHITECT \_\_\_\_\_

ENGINEER \_\_\_\_\_

CONTRACTOR \_\_\_\_\_

SUBMITTED BY \_\_\_\_\_ DATE \_\_\_\_\_

**UNIT SUMMARY**

Quantity						
Unit Designation						
Model No.						
Total Cooling						
Sensible Cooling						
Air Ent. Evaporator						
Air Lvg. Evaporator						
Heating Input						
Heating Output						
CFM/ESP						
EER/SEER						
Electrical						
Minimum Ampacity						
Min.-Max. Breaker						
Net Unit Weight						
Accessory						
Catalog Form Number						

**ACCESSORIES:**

**NOTES:**

# Endeavor® Line (-)A16AZ iM Air Conditioners

## Cooling Efficiencies up to: 17.0 SEER2/10.5 EER2

### Nominal Sizes: 2 to 5 Ton [7.0 to 17.6 kW]

JOB NAME \_\_\_\_\_ LOCATION \_\_\_\_\_

CONTRACTOR \_\_\_\_\_ ORDER NO. \_\_\_\_\_

ENGINEER \_\_\_\_\_ UNIT MODEL NO. \_\_\_\_\_

SUBMITTED FOR  APPROVAL  RECORD COIL MODEL NO. \_\_\_\_\_

DATE \_\_\_\_\_ AIR HANDLER MODEL NO. \_\_\_\_\_

#### UNIT DATA

##### COOLING PERFORMANCE

EFFICIENCY ..... SEER

TOTAL CAPACITY\* ..... MBH [kW]

SENSIBLE CAPACITY\* ..... MBH [kW]

OUTDOOR DESIGN TEMP..... °F [°C] DB

TEMP. OF AIR ENTERING  
EVAPORATOR COIL ..... °F [°C] DB

..... °F [°C] WB

POWER INPUT REQUIREMENT ..... kW  
(\*uses blower motor heat)

##### HEATING PERFORMANCE

EFFICIENCY ..... HSPF

TOTAL CAPACITY\* ..... MBH [kW]

OUTDOOR DESIGN TEMP..... °F [°C] DB

TEMP. OF AIR ENTERING  
EVAPORATOR COIL ..... °F [°C] DB

##### SUPPLY AIR BLOWER PERFORMANCE

TOTAL AIR SUPPLY..... CFM [L/s]

TOTAL RESISTANCE EXTERNAL  
TO UNIT ..... IWG

BLOWER SPEED..... RPM

POWER OUTPUT REQUIREMENT ..... BHP

MOTOR RATING ..... HP [W]

POWER INPUT REQUIREMENT ..... kW

##### ELECTRICAL DATA

POWER SUPPLY ..... Hz

TOTAL UNIT AMPACITY ..... AMPS

MINIMUM WIRE SIZE ..... AWG

MAXIMUM OVERCURRENT DEVICE  
FUSES/HACR BREAKER ..... AMPS

##### CLEARANCES

ACCESS SIDE 24" [609.6 mm]

AIR INLETS 12" [304.8 mm]

ABOVE UNIT 60" [1524 mm]



#### FEATURES

- **EcoNet® Enabled:** Automatic system configuration and optimization
- **PlusOne® Diagnostics & Bluetooth Connectivity:** With the Contractor & EcoNet® Apps, built-in technology makes advanced set-up, monitoring, troubleshooting and repairing the product easier than ever before
- **PlusOne® Variable Speed Twin Rotary Compressor & Inverter Drive:** Features Inverter operation from 40 to 100% capacity with the EcoNet® Smart Thermostat
- **3-Speed Operation** when installed with a 24V two-stage thermostat
- **Provides Precise Temperature Control,** advanced humidity control and greater efficiency
- **Brushless DC Condenser Motors (BLDC):** Enhances reliability and allows for easier serviceability
- **Swept Wing Fan Technology:** Features quieter operation and improved unit acoustics
- **7mm Condenser Copper Coil:** Requires less refrigerant allowing for a smaller and lighter footprint while enhancing reliability
- **PlusOne® Expanded Valve Space:** 3 in. – 4in. – 5 in. service valve space—provides a minimum working area of 27-square inches for easier access
- **PlusOne® Triple Service Access:** 15 in. wide, industry leading corner service access, two fastener, removeable corner and individual louver panels—makes repairs easier and faster

#### ACCESSORIES/OPTIONS

- Compressor Crankcase Heater.....
- Low Ambient Control.....
- Compressor Sound Cover.....
- Compressor Hard Start Kit.....
- Compressor Time Delay.....
- Low Pressure Control.....
- High Pressure Control.....



(-)A16AZ

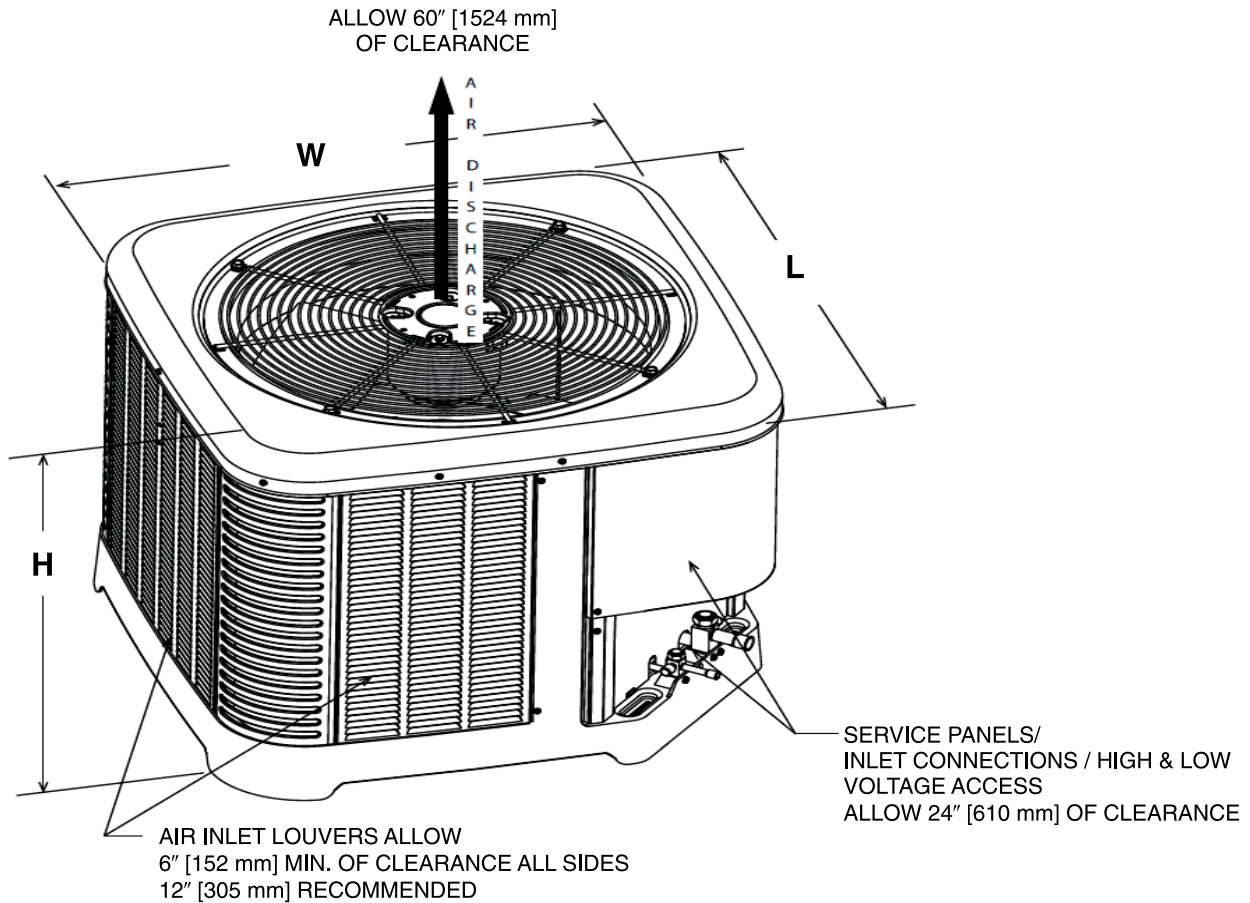

ST-A1226-02-00

### Unit Dimensions

MODEL NO.	OPERATING						SHIPPING					
	H (Height)		L (Length)		W (Width)		H (Height)		L (Length)		W (Width)	
	INCHES	mm	INCHES	mm	INCHES	mm	INCHES	mm	INCHES	mm	INCHES	mm
(-)A16AZ24AJ3	27.00	686	29.75	756	29.75	756	28.50	724	32.38	822	32.38	822
(-)A16AZ36AJ3	27.00	686	33.75	857	33.75	857	28.50	724	36.38	924	36.38	924
(-)A16AZ48AJ3	31.00	787	33.75	857	33.75	857	32.50	826	36.38	924	36.38	924
(-)A16AZ60AJ3	31.00	787	35.75	908	35.75	908	32.50	826	38.38	975	38.38	975

[ ] Designates Metric Conversions

Before proceeding with installation, refer to installation instructions packaged with each model, as well as complying with all Federal, State, Provincial, and Local codes, regulations, and practices.

Rheem Sales Company, Inc.  
5600 Old Greenwood Road  
Fort Smith, Arkansas 72908

© 2023 Rheem Manufacturing Company. Rheem and Ruud trademarks owned by Rheem Manufacturing Company.

"In keeping with its policy of continuous progress and product improvement, Rheem reserves the right to make changes without notice."