



The new degree of comfort.™

# SUBMITTAL COVER SHEET

PROJECT NAME \_\_\_\_\_

LOCATION \_\_\_\_\_

ARCHITECT \_\_\_\_\_

ENGINEER \_\_\_\_\_

CONTRACTOR \_\_\_\_\_

SUBMITTED BY \_\_\_\_\_ DATE \_\_\_\_\_

## UNIT SUMMARY

Quantity						
Unit Designation						
Model No.						
Total Cooling						
Sensible Cooling						
Air Ent. Evaporator						
Air Lvg. Evaporator						
Heating Input						
Heating Output						
CFM/ESP						
EER/SEER						
Electrical						
Minimum Ampacity						
Min.-Max. Breaker						
Net Unit Weight						
Accessory						
Catalog Form Number						

**ACCESSORIES:**

**NOTES:**





# Endeavor™ Line Select® Series iC Air Conditioners



*This product meets a stringent set of our internally defined sustainability standards*

## **WA15AZ**

Cooling Efficiency: 15.2 SEER2/9.8 EER2

Nominal Sizes: 2 to 5 Ton [7.0 to 17.6 kW]

Cooling Capacities: 17.1 to 55.5 kBTU [5.0 to 16.3 kW]

# Unit Dimensions

MODEL NO.	OPERATING						SHIPPING					
	H (Height)		L (Length)		W (Width)		H (Height)		L (Length)		W (Width)	
	INCHES	mm	INCHES	mm	INCHES	mm	INCHES	mm	INCHES	mm	INCHES	mm
WA15AZ24AJ3	27.00	686	29.75	756	29.75	756	28.50	724	32.38	822	32.38	822
WA15AZ36AJ3	27.00	686	33.75	857	33.75	857	28.50	724	36.38	924	36.38	924
WA15AZ48AJ3	31.00	787	33.75	857	33.75	857	32.50	826	36.38	924	36.38	924
WA15AZ60AJ3	31.00	787	35.75	908	35.75	908	32.50	826	38.38	975	38.38	975

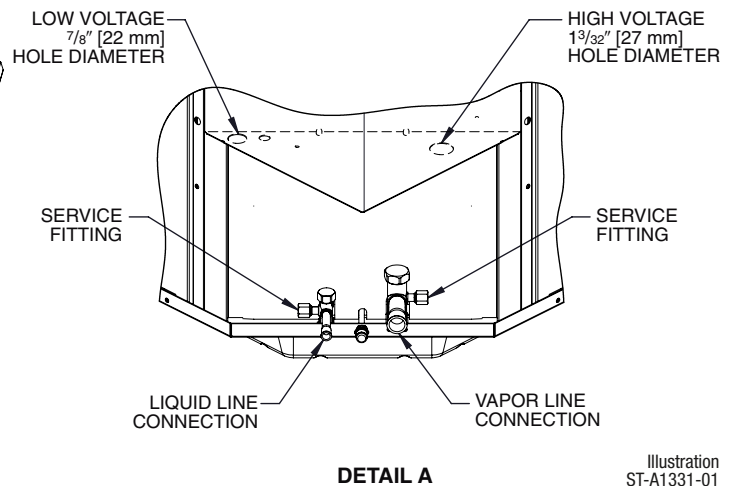
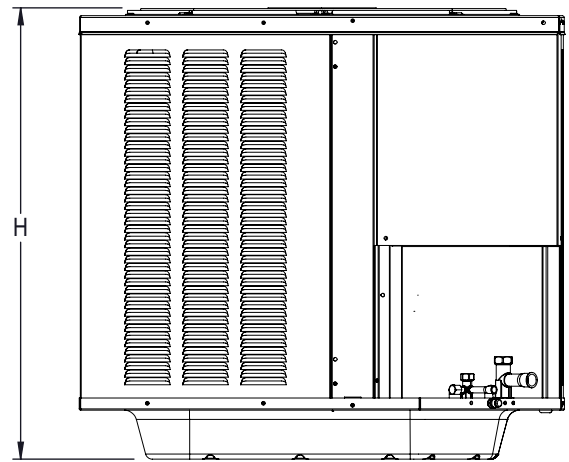
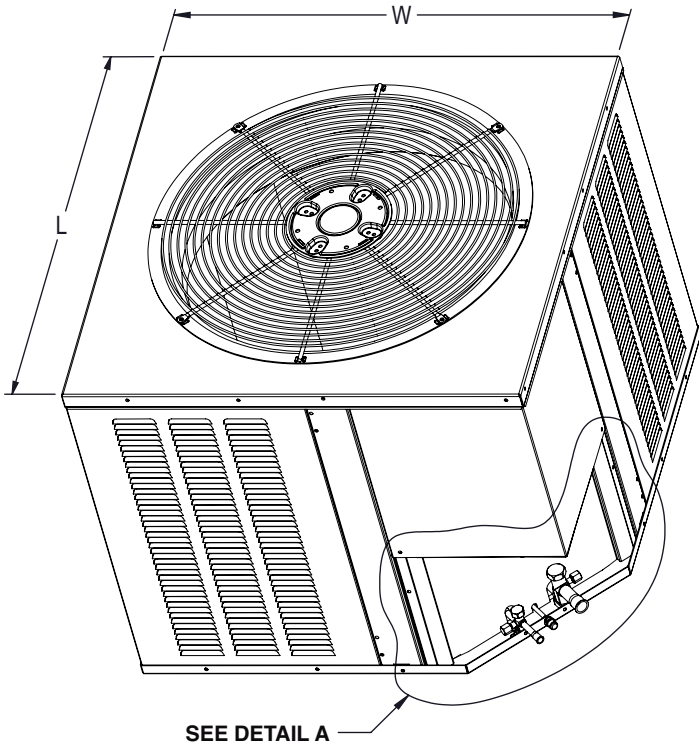

Illustration  
ST-A1331-01  
Rev. 10-20-2022

**NOTE:** Illustrations show the deep drawn basepan.

[ ] Designates Metric Conversions