



The new degree of comfort.®

PROJECT NAME _____
LOCATION _____
ARCHITECT _____
ENGINEER _____
CONTRACTOR _____
SUBMITTED BY _____ DATE _____

UNIT SUMMARY

Quantity						
Unit Designation						
Model No.						
Total Cooling						
Sensible Cooling						
Air Ent. Evaporator						
Air Lvg. Evaporator						
Heating Input						
Heating Output						
CFM/ESP						
EER/SEER						
Electrical						
Minimum Ampacity						
Min.-Max. Breaker						
Net Unit Weight						
Accessory						
Catalog Form Number						

ACCESSORIES:

NOTES:

Endeavor® Line (-)H2VZ Air Handlers

Nominal Sizes: 2 to 5 Ton [7.03 kW to 17.58 kW]

JOB NAME _____ LOCATION _____

CONTRACTOR _____ ORDER NO. _____

ENGINEER _____ UNIT MODEL NO. _____

SUBMITTED FOR APPROVAL RECORD COIL MODEL NO. _____

DATE _____ AIR HANDLER MODEL NO. _____

UNIT DATA

COOLING PERFORMANCE

EFFICIENCY SEER

TOTAL CAPACITY* MBH [kW]

SENSIBLE CAPACITY* MBH [kW]

OUTDOOR DESIGN TEMP..... °F [°C] DB

TEMP. OF AIR ENTERING
EVAPORATOR COIL °F [°C] DB

..... °F [°C] WB

POWER INPUT REQUIREMENT kW
(*uses blower motor heat)

HEATING PERFORMANCE

EFFICIENCY HSPF

TOTAL CAPACITY* MBH [kW]

OUTDOOR DESIGN TEMP..... °F [°C] DB

TEMP. OF AIR ENTERING
EVAPORATOR COIL °F [°C] DB

SUPPLY AIR BLOWER PERFORMANCE

TOTAL AIR SUPPLY..... CFM [L/s]

TOTAL RESISTANCE EXTERNAL
TO UNIT IWG

BLOWER SPEED..... RPM

POWER OUTPUT REQUIREMENT BHP

MOTOR RATING HP [W]

POWER INPUT REQUIREMENT kW

ELECTRICAL DATA

POWER SUPPLY Hz

TOTAL UNIT AMPACITY..... AMPS

MINIMUM WIRE SIZE AWG

MAXIMUM OVERCURRENT DEVICE
FUSES/HACR BREAKER AMPS

CLEARANCES

ACCESS SIDE 24" [609.6 mm]

AIR INLETS 12" [304.8 mm]

ABOVE UNIT 60" [1524 mm]



FEATURES

- Constant CFM Motor:**
 - When paired with EcoNet® Smart Thermostat, gradually auto-adjusts from low capacity to 100% of capacity to meet comfort requirements—allowing for ultimate humidity control, quieter sounds levels and year-round energy savings
 - When paired with 24V two-stage thermostat, air handler runs in 2 speeds to match airflow with outdoor unit
- Quieter Operation¹:** Provided by two-stage operation and truly variable speed airflow technology and sturdy cabinet construction with 1.0 inch of foil faced insulation for quieter sound characteristics
- PlusOne® Diagnostics:** With the Contractor & EcoNet® Apps, built-in EcoNet® & Bluetooth² technology makes monitoring, troubleshooting and repairing the product easier than ever before
- Dip Switch Free Installation Commissioning via Bluetooth® Technology:** Seamless final install step without DIP switch configuration using the Contractor App
- EcoNet® Enabled Air Handler³:**
 - The latest in sensor technology and the EcoNet® monitoring system provides a new level of protection, control and energy savings
 - Allows on-the-go control and receipt of system alerts by the homeowner via the EcoNet® Smart Thermostat and EcoNet® App⁴
- Aluminum Indoor Coil Design:** Are constructed of aluminum fins bonded to internally grooved aluminum tubing and are more corrosion resistant
- Versatile 4-Way Convertible Compact Design:** Allows for upflow, downflow, horizontal left and horizontal right applications, even in the smallest of spaces
- Rugged Steel, Compact Cabinet Construction:** Designed for added strength and versatility
- Field-installed Auxiliary Heater Kits:** Provide exact heat for indoor comfort and include circuit breakers which meet UL and cUL requirements for service disconnect
- Less than 2% Cabinet Air Leakage at 1-inch H₂O:** When tested in accordance with ASHRAE Standard 193

¹ Based on manufacturer's air handler offering, and the product's airflow stages, motor type and cabinet insulation. Sound levels are also dependent on air handler location and installation.

² The Bluetooth® word mark and logos are registered trademarks owned by Bluetooth SIG, Inc. and any use of such marks by Rheem® is under license. Other trademarks and trade names are those of their respective owners.

³ Fully communicating systems coming soon. Non-communicating system EcoNet® benefits include demand response connection and unit monitoring.

⁴ Wifi broadband internet connection required. Download the EcoNet® App from the App Store® or Google Play® to set up your EcoNet® Smart Thermostat. Receipt of notifications depend on home WiFi set up. Amazon, Alexa and all related logos are trademarks of Amazon.com, Inc. or its affiliates.



(-)H2VZ

ELECTRICAL CONNECTIONS
MAY EXIT TOP OR EITHER SIDE

HIGH VOLTAGE CONNECTION 7/8" [22.2 mm],
1 3/32" [27.8 mm], 1 3/32" [50 mm] DIA, KNOCKOUTS.

LOW VOLTAGE CONNECTION
3/8" [15.9 mm] AND 7/8" [22.2 mm] KNOCKOUT

AUXILIARY DRAIN CONNECTION
3/4" [19.1 mm] FEMALE PIPE THREAD (NPT)
HORIZONTAL APPLICATION ONLY

PRIMARY DRAIN CONNECTION
3/4" [19.1 mm] FEMALE PIPE THREAD (NPT)

AUXILIARY DRAIN CONNECTION
3/4" [19.1 mm] FEMALE PIPE THREAD (NPT)
UPFLOW/DOWNFLOW APPLICATION ONLY

LIQUID LINE CONNECTION
COPPER (SWEAT)

VAPOR LINE CONNECTION
COPPER (SWEAT)

SUPPLY AIR ↑

NOTE: 24" CLEARANCE REQUIRED IN FRONT OF
UNIT FOR FILTER AND COIL MAINTENANCE.

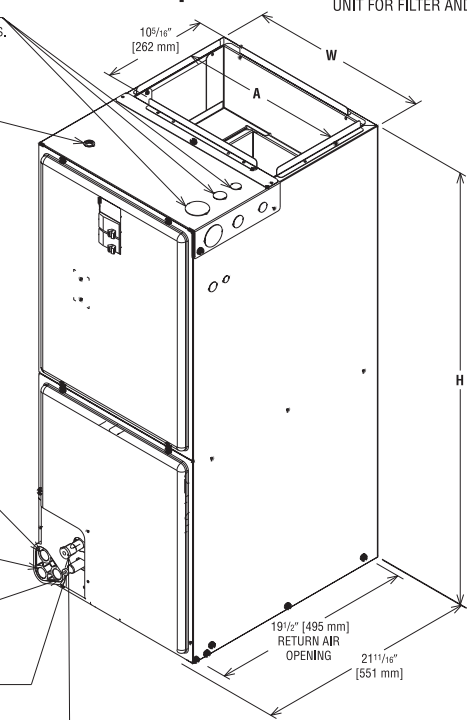

UPFLOW UNIT SHOWN:
UNIT MAY BE INSTALLED UPFLOW, DOWNFLOW,
HORIZONTAL RIGHT OR LEFT AIR SUPPLY.

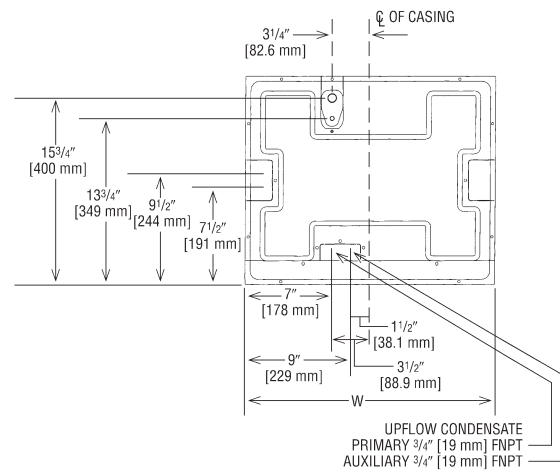

Unit Dimensions

Model Family	Model Size (-)H2VZ	Refrigerant Connections Sweat (In.) [mm] ID		Unit Width "W" In. [mm]	Unit Height "H" In. [mm]	Supply Duct "A" In. [mm]	Unit Weight/Shipping Weight (Lbs.) [kg]
		Liquid	Vapor				Unit With Coil (Max. KW)
(-)H2VZ	2417STANN	3/8 [9.53]	3/4 [19.05]	17 1/2 [445]	42 1/2 [1080]	16 [406]	91/105 [41/48]
	3617STANN	3/8 [9.53]	3/4 [19.05]	17 1/2 [445]	42 1/2 [1080]	16 [406]	98/112 [44/51]
	3621STANN	3/8 [9.53]	3/4 [19.05]	21 [533]	42 1/2 [1080]	19 1/2 [495]	103/118 [47/54]
	3621MTANN	3/8 [9.53]	7/8 [22.23]	21 [533]	50 1/2 [1282]	19 1/2 [495]	126/142 [57/64]
	3621MTANA	3/8 [9.53]	7/8 [22.23]	21 [533]	57 [1448]	19 1/2 [495]	138/150 [63/68]
	4821STANN	3/8 [9.53]	7/8 [22.23]	21 [533]	50 1/2 [1282]	19 1/2 [495]	128/144 [56/65]
	4821STANA	3/8 [9.53]	7/8 [22.23]	21 [533]	57 [1448]	19 1/2 [495]	140/152 [64/69]
	4824STANN	3/8 [9.53]	7/8 [22.23]	24 1/2 [622]	55 1/2 [1410]	23 [584]	142/160 [64/73]
	6021STANA	3/8 [9.53]	7/8 [22.23]	21 [533]	57 [1448]	19 1/2 [495]	140/152 [64/69]
6024STANN	3/8 [9.53]	7/8 [22.23]	24 1/2 [622]	55 1/2 [1410]	23 [584]	159/176 [72/80]	

[] Designates Metric Conversions

Before proceeding with installation, refer to installation instructions packaged with each model, as well as complying with all Federal, State, Provincial, and Local codes, regulations, and practices.

5600 Old Greenwood Road
Fort Smith, Arkansas 72908

© 2023 Rheem Manufacturing Company. Rheem, Ruud and Friedrich trademarks owned by Rheem Manufacturing Company.

"In keeping with its policy of continuous progress and product improvement, Rheem reserves the right to make changes without notice."