

# Encore®

## Richmond® Encore® L-Series Super High-Efficiency Condensing Combi Boilers

### FLEXIBLE INSTALLATION

- Moveable combustion air intake (left/right) and ability to flex vent in existing B-vent
- Extra long pipe fittings with notched sides for easy gripping with wrench
- Only 5 moving parts – Fan, Bypass Valve, Pump, Gas Valve, and Damper
- Universal shared platform parts – Easily diagnose and service with common parts for all L-Series units

### KEY FEATURES

- Innovative Labyrinth Heat Exchanger with 2 independent copper waterways for maximum heat transfer and minimal heat loss

- Built-in ECM variable speed, high efficiency boiler pump
- Built-in Illuminated Touchscreen Control Panel
- Outdoor reset technology increases efficiency by lowering water temperature automatically
- Wireless cascading using RF balances workload of each unit for longer life
- Only Combi Boilers that can be cascaded for both space heating and domestic hot water
- ENERGY STAR® certified with up to 95% AFUE and ASME-rated (excludes 160K combi model).

### Specifications

MODEL NO.		RMCBH-L125i	RMCBH-L160i	RMCBH-L199i
Input Rate (Heating Mode)	MAX	99,000 BTU/h	125,000 BTU/h	125,000 BTU/h
	MIN	16,500 BTU/h	23,000 BTU/h	28,500 BTU/h
Output Rate (Heating mode)	MAX	89,000 BTU/h	111,000 BTU/h	111,000 BTU/h
	MIN	15,800 BTU/h	22,000 BTU/h	27,100 BTU/h
Input Rate (Domestic Hot Water)	MAX	125,000 BTU/h	160,000 BTU/h	199,000 BTU/h
	MIN	16,500 BTU/h	23,000 BTU/h	28,500 BTU/h
AFUE		95%	94%	95%
Gas Pressure (Nat Gas or LP gas)	MAX	14" WC		
	MIN	4" WC		
Power Supply		120V/60Hz		
Weight lbs. (empty)		85	84	
Pressure vessel water content – USG		0.5	0.19	
Boiler Flow Rate - GPM	MAX	10	11	12
	MIN	2		
Water Pressure	MAX	DHW 150 psi / Heating 43.5psi		
	MIN	DHW 40psi / Heating 8psi		
Maximum Altitude		10,100 ft	10,100 ft	10,100 ft <sup>3</sup>
Ambient temperature – Low (°F)		32°		
Ambient temperature – High (°F)		122°		
Max relative humidity (non-condensing)		90%		
Temp Range	Heating Mode	51°F-194°F		
	Domestic Hot Water	105°F-149°F		
Minimum Activation Flow Rate (DHW)		0.5 GPM		
Gallons per Minute - GPM (Domestic Hot Water)	MAX	4	7	
	67°F Rise	3.2	4.1	5
Gas Connection		3/4" Male NPT		
Domestic Hot Water Connection		3/4" Male NPT		
Heating Connection		1" Male NPT		
Max equivalent vent length 2" (each side) <sup>2</sup>		65'		
Max equivalent vent length 3" (each side)		120'		
Ultra Low NOx		Meets 14ng/J NOx requirements - SCAQMD Rule 1146.2 compliant		
Warranty <sup>1</sup>		10-Year Heat Exchanger, 5-Year Parts, 1-Year Labor		

<sup>1</sup>See Warranty Certificate for complete information. <sup>2</sup>Approximate input derate of 10 - 16% at 2" maximum vent length. <sup>3</sup>Natural Gas only, LP is 7,800 ft

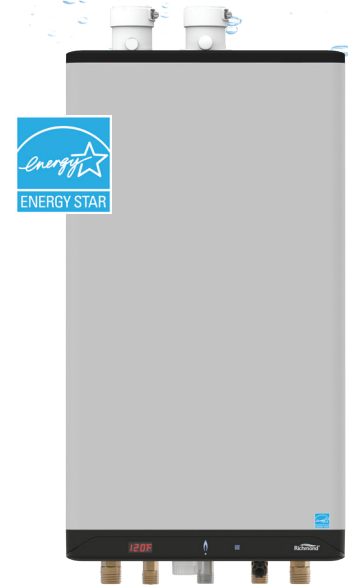

**RMCBH-L125i, RMCBH-L160i & RMCBH-L199i**  
Indoor Direct Vent  
125,000-199,000 BTU/h  
Natural Gas/LP Convertible

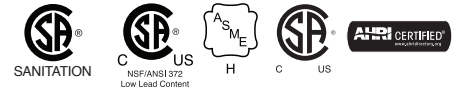

**Water heater pressure drop – L-Series**  
RMCBH-L125i, RMCBH-L160i & RMCBH-L199i

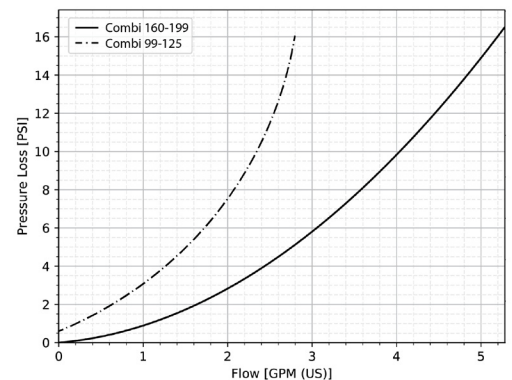

# Richmond® Encore® L-Series Super High-Efficiency Condensing Combi Boilers

View the boiler head loss – L-Series RMCBH-L125i, RMCBH-L160i & RMCBH-L199i

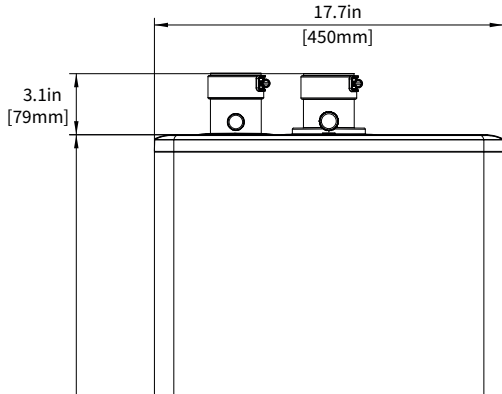

## Specifications

VENTING	MAXIMUM EQUIVALENT LENGTH
<b>Schedule 40 PVC, CPVC or Polypropylene</b>	(each side)
2"	65' <sup>2</sup>
3"	120'
2" or 3" 90° Long Sweep Vent Elbow	Allow 5 equivalent feet
2" or 3" 90° Short Sweep Vent Elbow	Allow 8 equivalent feet
2" or 3" 45° Vent Elbow	Allow 3 equivalent feet
<b>Polypropylene</b>	
PPs 87-90° Elbow	Allow 8 equivalent feet
<b>Flex PPS</b>	
3" PPs Flex	35' Actual (Equivalent = Actual x 1.4)

<sup>2</sup> Approximate input derate of 10 - 16% at 2" maximum vent length.

SURFACE	MIN. DISTANCE FROM COMBUSTIBLE SURFACES	RECOMMENDED DISTANCE FOR INSTALLATION AND SERVICE
Front	2"	24"
Rear	0"	0"
Left Side	1.5"	6"
Right Side	4"	6"
Top	2"	24"
Bottom	8"	24"

	PIPING CONNECTIONS	DIMENSION
A	Exhaust Outlet	2" Schedule 40 PVC
B	Combustion Air Inlet	2" Schedule 40 PVC
C	Cold Domestic Water Connection	3/4" Male NPT
D	Hot Domestic Water Connection	3/4" Male NPT
E	Heating Water Inlet	1" Male NPT
F	Heating Water Outlet	1" Male NPT
G	Gas Inlet	3/4" Male NPT
H	Condensate Outlet	3/4" Hose
I	Control Wiring	7/16" Rubber Plug

## Dimensions

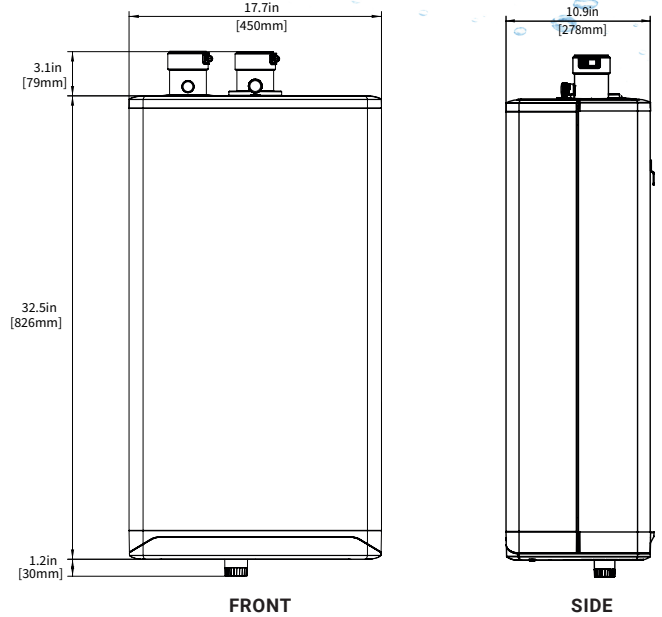

FRONT

SIDE

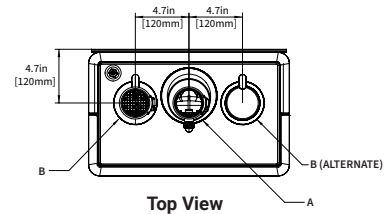

Top View

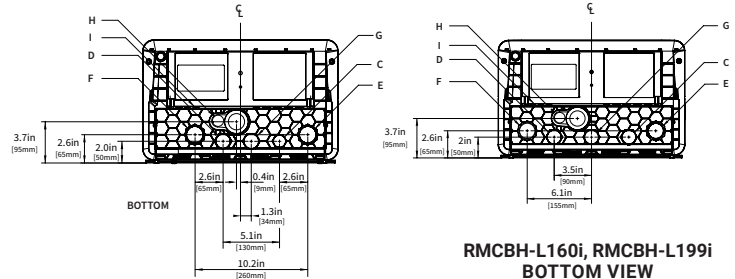

RMCBH-L125i  
BOTTOM VIEW

RMCBH-L160i, RMCBH-L199i  
BOTTOM VIEW

## Parts & Accessories

Floor Stand P-267C	Service Parts Kit P-911R	EZ Pipe Manifold 251-063, 251-064	2" PVC Sidewall Vent Kit P-741	3" PVC Sidewall Vent Kit P-742

In keeping with its policy of continuous progress and product improvement, Richmond reserves the right to make changes without notice.