

RUUD® XTREME™



A Powerful
Line of Fast
Recovery
Commercial
Gas Water
Heaters

90-Gallon Capacity
500,000-715,000 BTU/h



Ruud.com/CommercialWaterHeating

RUUD® XTREME™

HIGH INPUT, FAST RECOVERY
COMMERCIAL WATER HEATERS
COMPLYING WITH LOW NO_x EMISSIONS



90-GALLON MODELS RANGE FROM 500,000-715,000 BTU/H and deliver up to 756 gallons per hour at a 100 degree F rise.

XTREME MAXIMIZES INSTALLATION FLEXIBILITY with 30" diameters, tank height under 75" and multiple water connections.

PATENTED MULTI-FLUE TANK DESIGN Patented multi-flue design, and two coats of high temperature porcelain enamel to maximize corrosion resistance result in a superior heat exchanger design.

LOW PROFILE AUTOMATIC FLUE DAMPER Low profile design minimizes overall product height. Heavy duty vent hood supports are designed to withstand rigors of installation.

DIRECT SPARK-TO-PILOT IGNITION SYSTEM Standard on all models. Energy saving ignition that ignites pilot only when there is a call for heat.

FULL PORT, FULL FLOW BRASS DRAIN VALVE

TEMPERATURE AND PRESSURE RELIEF VALVE AGA/ASME rated and factory installed.

HAND-HOLE CLEANOUT For removal of lime/sediment deposits.

MANUAL RESET HIGH LIMIT All ASME models are factory equipped with a manual reset high limit to meet the code requirements of many states.

PATENTED ANODE RODS Anode design utilizes multiple magnesium rods to ensure corrosion resistance for a long tank life.

FIBERGLASS INSULATION Sag and moisture proof

FULLY ADJUSTABLE THERMOSTAT 100°F to 180°F

24 VOLT COMBINATION GAS VALVE Includes main gas pressure regulation

LOW NO_x EMISSIONS GX90-550 and GX90-640 meet low NO_x emissions of less than 40 ng/J.

ON-OFF MANUAL VALVE

120/24 VOLT TRANSFORMER



SYSTEM SENTINEL™ LED DIAGNOSTIC SYSTEM

Our exclusive diagnostic system, with glowing LED lights, verifies system

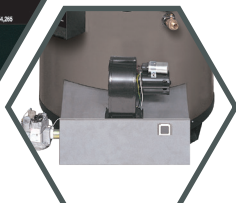

SPECIALIZED BURNER ASSEMBLY

Five pre-mix burners mounted into a metal face plate and sealed with a Viton gasket

RECOVERY CAPACITIES Recovery in U.S. Gallons/Hr. (GPH) at Various Temperature Rises.														
MODEL NUMBER	INPUT (BTU/H) NAT. & LP	ASME CERTIFIED		Temp. Rise – GPH										
		THERMAL EFF.	STANDBY LOSS (BTU/H)	40° F	50° F	60° F	70° F	80° F	90° F	100° F	110° F	120° F	130° F	140° F
GX90-550(A)	550,000 NAT	80%	1668.0	1333	1067	889	762	667	593	533	485	444	410	381
GX90-640(A)	640,000 NAT	80%	1793.0	1551	1241	1034	887	776	690	621	564	517	477	443
GX90-715(A)	715,000 NAT	80%	1893.0	1733	1387	1156	991	867	770	693	630	578	533	495
GX90-500(A)	500,000 LP	80%	1668.0	1212	970	808	693	606	539	485	441	404	373	346
GX90-600(A)	600,000 LP	80%	1793.0	1455	1164	970	831	727	647	582	529	485	448	416
GX90-680(A)	680,000 LP	80%	1893.0	1649	1319	1099	942	824	733	659	599	550	507	471

Recovery ratings are based on thermal efficiencies obtained in a CSA certified laboratory. Recovery rate shown on the rating plate (80%) Thermal Efficiency in accordance with ANSI Z21.10.3 labeling requirements. (A) indicates available ASME model.

MAXIMUM DELIVERY (in gallons) (Includes useable storage and recovery for indicated times)											
MODEL NUMBER	TANK CAP.	INPUT (BTU/H) NAT. & LP	AT 100°F TEMP RISE								
			10 MIN.	20 MIN.	30 MIN.	45 MIN.	60 MIN.	120 MIN.	180 MIN.	MIN. TO REC. CONTENTS	
GX90-550(A)	90	550,000 NAT	152	241	330	463	596	1130	1663	10	
GX90-640(A)	90	640,000 NAT	166	270	373	529	684	1304	1925	9	
GX90-715(A)	90	715,000 NAT	179	294	410	583	756	1450	2143	8	
GX90-500(A)	90	500,000 LP	144	225	305	427	548	1033	1518	11	
GX90-600(A)	90	600,000 LP	160	257	354	499	645	1227	1809	9	
GX90-680(A)	90	680,000 LP	173	283	393	558	722	1382	2041	8	

DIMENSIONAL INFORMATION (shown in inches)								WATER CONNECTIONS		APPROX. SHIP. WT.	
MODEL NUMBER	A	B	C	D	E	F	G	FRONT SIDE	REAR SIDE	STD. (LBS.)	ASME (LBS.)
GX90-550(A)	74.5	68	30	25	10	59	1	2	2	905	945
GX90-640(A)	74.5	68	30	25	10	59	1	2	2	905	945
GX90-715(A)	74.5	68	30	25	10	59	1	2	2	905	945
GX90-500(A)	74.5	68	30	25	10	59	1	2	2	905	945
GX90-600(A)	74.5	68	30	25	10	59	1	2	2	905	945
GX90-680(A)	74.5	68	30	25	10	59	1	2	2	905	945

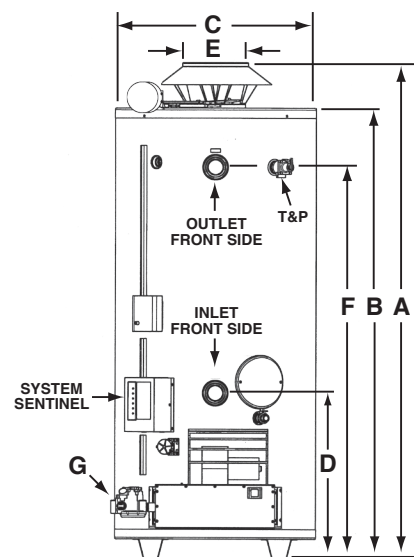

CLEARANCE TO COMBUSTIBLES			
MODEL NUMBER	SIDE	REAR	TOP
GX90-550(A)	4	4	12
GX90-640(A)	4	4	12
GX90-715(A)	4	4	12
GX90-500(A)	4	4	12
GX90-600(A)	4	4	12
GX90-680(A)	4	4	12

Allow a minimum of 18" front clearance for servicing. 2.5 Amps.



RUUD[®] XTREME[™]



Warranty

3-Year limited tank warranty



Certification and Ratings

Efficiency All models tested according to ANSI test procedures, and meet or exceed the thermal efficiency and standby loss requirements of ASHRAE standard (EPact). Also exceeds energy efficiency codes of all states including California Energy Commission (CEC).



Altitude Certifications

Standard Natural and LP models are certified up to 2,000 feet. High altitude models, 8,000 feet.



Safety and Construction

These products are design certified by the UL:

- a) For operation at 180°F.
- b) To meet all safety and construction requirements of ANSI Z21.10.3-2001.
- c) As an automatic storage or instantaneous water heater.
- d) As an automatic circulating tank water heater.
- e) For operation on combustible floors and in alcove installations.



Certified for a 150 PSI Maximum Working Pressure (160 PSI for ASME Models)



Optional Constructions

ASME construction is available on designated models.



Contact Us

Customer Service, Warranty, Parts

800.621.5622

Plumbing Support Team

866.339.2388

Technical Service

800.HEATER3 (800.432.8373)

Visit us online at

Ruud.com/CommercialWaterHeating

In keeping with its policy of continuous progress and product improvement, Ruud reserves the right to make changes without notice.

Ruud Water Heating
1115 Northmeadow Parkway, Suite 100
Roswell, Georgia 30076

PRINTED IN U.S.A. • 08/23 • WP • RH-RR102LN

PRINTED IN U.S.A. • 08/23 • WP • RU-RR170

