



## Vantix™ Line iM Heat Pumps



### SP14AY

Cooling Efficiencies up to: 15.2 SEER2 / 11.7 EER2

Heating Efficiencies up to: 7.8 HSPF2

Nominal Sizes: 1.5 to 5 Tons [5.3 to 17.6 kW]

Cooling & Heating Capacities: 17.1 kBTU to 54.0 kBTU [5.0 kW to 15.8 kW]

Refrigerant Type: R-454B



*\*Proper sizing and installation of equipment is critical to achieve optimal performance. Split system air conditioners and heat pumps must be matched with appropriate coil components to meet ENERGY STAR®. Ask your Contractor for details or visit [www.energystar.gov](http://www.energystar.gov).*

## Table of Contents

Features and Benefits .....	3
Model Number Identification .....	4
General Data/Electrical Data .....	5
Accessories .....	6
Weighted Sound Power .....	6
Unit Dimensions .....	7
Clearances .....	8
Refrigerant Line Size Information .....	9-10
Performance Data .....	11
Limited Warranty .....	12

## Features and Benefits

- **Two-Stage Scroll Compressor<sup>1</sup>:** Features two speeds (high and low) of cooling and heating, providing more precise temperature control, lower humidity and greater efficiency when compared to single stage compressors
- **Inverted Reversing Valve:** Allows for faster heat transfer with gravity assist shifting and reduced joint stress for increased reliability
- **Expanded Valve Space:** 3 in. – 4 in. – 5 in. service valve space—provides a minimum working area of 27-square inches for easier access
- **Triple Service Access:** 15 in. wide, industry leading corner service access, makes repairs easier and faster
- **Designing for Sustainability with Low GWP:** For 2025, the Environmental Protection Agency (EPA) has set a global warming potential (GWP) limit of 700 for refrigerant used in heating and cooling systems. This new requirement will result in a 78%<sup>2</sup> lower GWP than previous-generation refrigerants — with only minimal changes to system installation. For us, this is another step toward our continued sustainability goal of reducing greenhouse gas emissions, while still delivering an exceptional level of energy efficient, dependable comfort
- **Refrigerant Detection System<sup>3</sup>:** An integrated one-box, patented design featuring the A2L sensor and mitigation board, offering easier commissioning with a single component and simplified wiring configuration, compatibility with any 24V thermostat application and system protection by automatically pausing outdoor unit operation — if excess refrigerant is detected

<sup>1</sup>Does not apply to the 1.5 Ton 1-stage model

<sup>2</sup>When comparing the GWP of R-454B to R-410A refrigerant

<sup>3</sup>Factory or field installed in the furnace coil or air handler and is applicable to the complete heating and cooling system featuring Low GWP Refrigerant (A2L)

# Heat Pumps

<u>S</u>	<u>P</u>	<u>14</u>	<u>A</u>	<u>Y</u>	<u>18</u>	<u>A</u>	<u>J</u>	<u>1</u>	<u>N</u>	<u>A</u>	<u>A40</u>
Brand	Product Category	SEER2	Region	Refrigerant	Capacity	Major Series	Voltage	Type	Controls	Minor Series	Option
S - Russell® By Rheem	P - Heat Pump	14 - 14.3 SEER2	A - All Regions	Y - R-454B	18 - 18,000 [5.28 kW] 24 - 24,000 [7.03 kW] 30 - 30,000 [8.79 kW] 36 - 36,000 [10.55 kW] 42 - 42,000 [12.31 kW] 48 - 48,000 [14.07 kW] 60 - 60,000 [17.58 kW]	A - 1st Design	J - 1ph, 208/230/60 C - 3ph, 208/230/60 D - 3ph, 460/60	1 - 1-Stage 2 - 2-Stage	N - Non-Comm.	A - 1st Design	A40 - Vertical Louvers

[ ] Designates Metric Conversions

AVAILABLE MODELS
SP14AY18AJ1NA
SP14AY18AJ1NAA40
SP14AY24AJ2NA
SP14AY24AJ2NAA40
SP14AY30AJ2NA
SP14AY30AJ2NAA40
SP14AY36AJ2NA
SP14AY36AJ2NAA40
SP14AY36AC2NA
SP14AY36AC2NAA40
SP14AY36AD2NA
SP14AY36AD2NAA40
SP14AY42AJ2NA
SP14AY42AJ2NAA40
SP14AY42AC2NA
SP14AY42AC2NAA40
SP14AY42AD2NA
SP14AY42AD2NAA40
SP14AY48AJ2NA
SP14AY48AJ2NAA40
SP14AY48AC2NA
SP14AY48AC2NAA40
SP14AY48AD2NA
SP14AY48AD2NAA40
SP14AY60AJ2NA
SP14AY60AJ2NAA40
SP14AY60AC2NA
SP14AY60AC2NAA40
SP14AY60AD2NA
SP14AY60AD2NAA40

STANDARD EQUIPMENT
R-454B Refrigerant
Scroll Compressor
Field Installed Filter Drier
Front Seating Service Valves
Internal Pressure Relief Valve
Internal Thermal Overload
Long Line capability
Low Ambient capability with Kit
3-4-5 Expanded Valve Space
Composite Basepan
2 Screw Control Box Access
15" Access to Internal Components
No fasteners to remove along bottom
Optimized Venturi Airflow
Powder coated paint
Rust resistant screws
QR code
External gauge ports
Service trays

<b>General Data</b>							
MODEL NO.	SP14AY18A	SP14AY24A	SP14AY30A	SP14AY36A	SP14AY42A	SP14AY48A	SP14AY60A
Nominal Tonnage	1.5	2.0	2.5	3.0	3.5	4.0	5.0
<b>Valve Connections</b>							
Liquid Line O.D. – in.	3/8	3/8	3/8	3/8	3/8	3/8	3/8
Suction Line O.D. – in.	3/4	3/4	3/4	3/4	7/8	7/8	7/8
Refrigerant (R-454B) furnished oz. <sup>1</sup>	83	83	99	94	130	115	194
Compressor Type	Scroll						
<b>Outdoor Coil</b>							
Net face area – Outer Coil	10.9	10.9	14.4	19.5	19.5	19.5	23.4
Net face area – Inner Coil	—	—	—	—	—	—	22.7
Tube diameter – in.	0.276	0.276	0.276	0.276	0.276	0.276	0.276
Number of rows	1	1	1	1	1	1	2
Fins per inch	22	22	22	22	22	24	22
<b>Outdoor Fan</b>							
Diameter – in.	20	20	24	24	24	24	26
Number of blades	3	3	3	3	3	3	3
Motor hp	1/7	1/6	1/5	1/5	1/5	1/5	1/5
CFM	2401	2620	3391	4077	4077	4096	4396
RPM	1075	1075	850	850	850	850	850
Watts	146	145	175	234	222	236	284
Shipping weight – lbs.	160	160	196	209	239	243	282
Operating weight – lbs.	153	153	189	202	232	236	275

<b>Electrical Data</b>							
Line Voltage Data (Volts-Phase-Hz)	208/230-1-60	208/230-1-60	208/230-1-60	208/230-1-60	208/230-1-60	208/230-1-60	208/230-1-60
Maximum overcurrent protection (amps) <sup>2</sup>	20	25	30	30	40	45	50
Minimum circuit ampacity <sup>3</sup>	13	16	20	20	24	27	33
<b>Compressor</b>							
Rated load amps	10	12	15	15	18	20	25
Locked rotor amps	52	65	82	90	106	141	147
<b>Condenser Fan Motor</b>							
Full load amps	0.75	0.75	1.0	1.0	1.0	1.0	1.0
Locked rotor amps	1.4	1.5	2.6	2.56	2.56	2.56	2.6
Line Voltage Data (Volts-Phase-Hz)				208/230-3-60	208/230-3-60	208/230-3-60	208/230-3-60
Maximum overcurrent protection (amps) <sup>2</sup>				20	25	25	30
Minimum circuit ampacity <sup>3</sup>				13	16	17	19
<b>Compressor</b>							
Rated load amps				9.4	11.2	10.8	13.8
Locked rotor amps				82	123	123	150
<b>Condenser Fan Motor</b>							
Full load amps				1.0	1.0	1.0	1.0
Locked rotor amps				2.60	2.60	2.60	2.6
Line Voltage Data (Volts-Phase-Hz)				460-3-60	460-3-60	460-3-60	460-3-60
Maximum overcurrent protection (amps) <sup>2</sup>				15	15	15	15
Minimum circuit ampacity <sup>3</sup>				7	9	10	10
<b>Compressor</b>							
Rated load amps				5	5.8	7.1	6.5
Locked rotor amps				44	60	60	60
<b>Condenser Fan Motor</b>							
Full load amps				0.8	1.0	1.0	1.0
Locked rotor amps				1.4	1.4	1.4	1.4

<sup>1</sup>Refrigerant charge sufficient for 15 ft. length of refrigerant lines. For longer line set requirements see the installation instructions for information about set length and additional refrigerant charge required.

<sup>2</sup>HACR type circuit breaker or fuse.

<sup>3</sup>Refer to National Electrical Code manual to determine wire, fuse and disconnect size requirements.

## Accessories

MODEL NO.		SP14AY18A	SP14AY24A	SP14AY30A	SP14AY36A	SP14AY42A	SP14AY48A	SP14AY60A
Compressor crankcase heater*		44-17402-44	44-17402-44	44-17402-44	44-17402-44	44-17402-45	44-17402-45	Factory Standard
Low ambient control		RXAD-A08	RXAD-A08	RXAD-A08	RXAD-A08	RXAD-A08	RXAD-A08	RXAD-A08
Compressor sound cover		68-23427-26	68-23427-26	68-23427-26	68-23427-26	68-23427-25	68-23427-25	68-23427-25
Compressor hard start kit		SK-A1	SK-A1	SK-A1	SK-A1	SK-A1	SK-A1	SK-A1
Low pressure control		Factory Standard	Factory Standard	Factory Standard	Factory Standard	Factory Standard	Factory Standard	Factory Standard
High pressure control		Factory Standard	Factory Standard	Factory Standard	Factory Standard	Factory Standard	Factory Standard	Factory Standard
Liquid Line Solenoid (24 VAC, 50/60 Hz)	Solenoid Valve	200RD2T3TVLC	200RD2T3TVLC	200RD2T3TVLC	200RD2T3TVLC	200RD2T3TVLC	200RD3T3TVLC	200RD3T3TVLC
	Solenoid Coil	61-AMG24V	61-AMG24V	61-AMG24V	61-AMG24V	61-AMG24V	61-AMG24V	61-AMG24V
Liquid Line Solenoid (120/240 VAC, 50/60 Hz)	Solenoid Valve	200RD2T3TVLC	200RD2T3TVLC	200RD2T3TVLC	200RD2T3TVLC	200RD2T3TVLC	200RD3T3TVLC	200RD3T3TVLC
	Solenoid Coil	61-AMG120/240V	61-AMG120/240V	61-AMG120/240V	61-AMG120/240V	61-AMG120/240V	61-AMG120/240V	61-AMG120/240V

\*Bi-flow kits are required when installing a liquid line solenoid on a heat pump.

## Weighted Sound Power Level (dBA)

UNIT SIZE - VOLTAGE, SERIES	STANDARD RATING (DBA)	TYPICAL OCTAVE BAND SPECTRUM (dBA without tone adjustment)						
		125	250	500	1000	2000	4000	8000
SP14AY18A	73	39.8	55.0	62.1	67.0	60.0	57.4	51.2
SP14AY24A	73	40.4	55.4	62.5	65.9	58.7	56.4	48.9
SP14AY30A	72	48.9	55.3	63.6	61.0	59.1	56.5	48.7
SP14AY36A	72	50.1	55.8	64.4	61.5	58.7	55.1	50.9
SP14AY42A	72	48.6	56.2	63.1	61.7	60.0	56.0	50.0
SP14AY48A	74	49.3	56.0	64.5	64.5	60.1	54.9	47.7
SP14AY60A	74	43.9	55.2	63.4	65.8	61.7	57.9	52.9

**NOTE:** Tested in accordance with AHRI Standard 270-08 (not listed in AHRI)

## Unit Dimensions

MODEL NO.	OPERATING						SHIPPING					
	H (Height)		L (Length)		W (Width)		H (Height)		L (Length)		W (Width)	
	INCHES	mm	INCHES	mm	INCHES	mm	INCHES	mm	INCHES	mm	INCHES	mm
SP14AY18A	25.00	635	29.75	756	29.75	756	26.50	673	32.38	822	32.38	822
SP14AY24A	25.00	635	29.75	756	29.75	756	26.50	673	32.38	822	32.38	822
SP14AY30A	27.00	686	33.75	857	33.75	857	28.50	724	36.38	924	36.38	924
SP14AY36A	35.00	889	33.75	857	33.75	857	36.50	927	36.38	924	36.38	924
SP14AY42A	35.00	889	33.75	857	33.75	857	36.50	927	36.38	924	36.38	924
SP14AY48A	35.00	889	33.75	857	33.75	857	36.50	927	36.38	924	36.38	924
SP14AY60A	39.00	991	35.75	908	35.75	908	40.50	1029	38.38	975	38.38	975

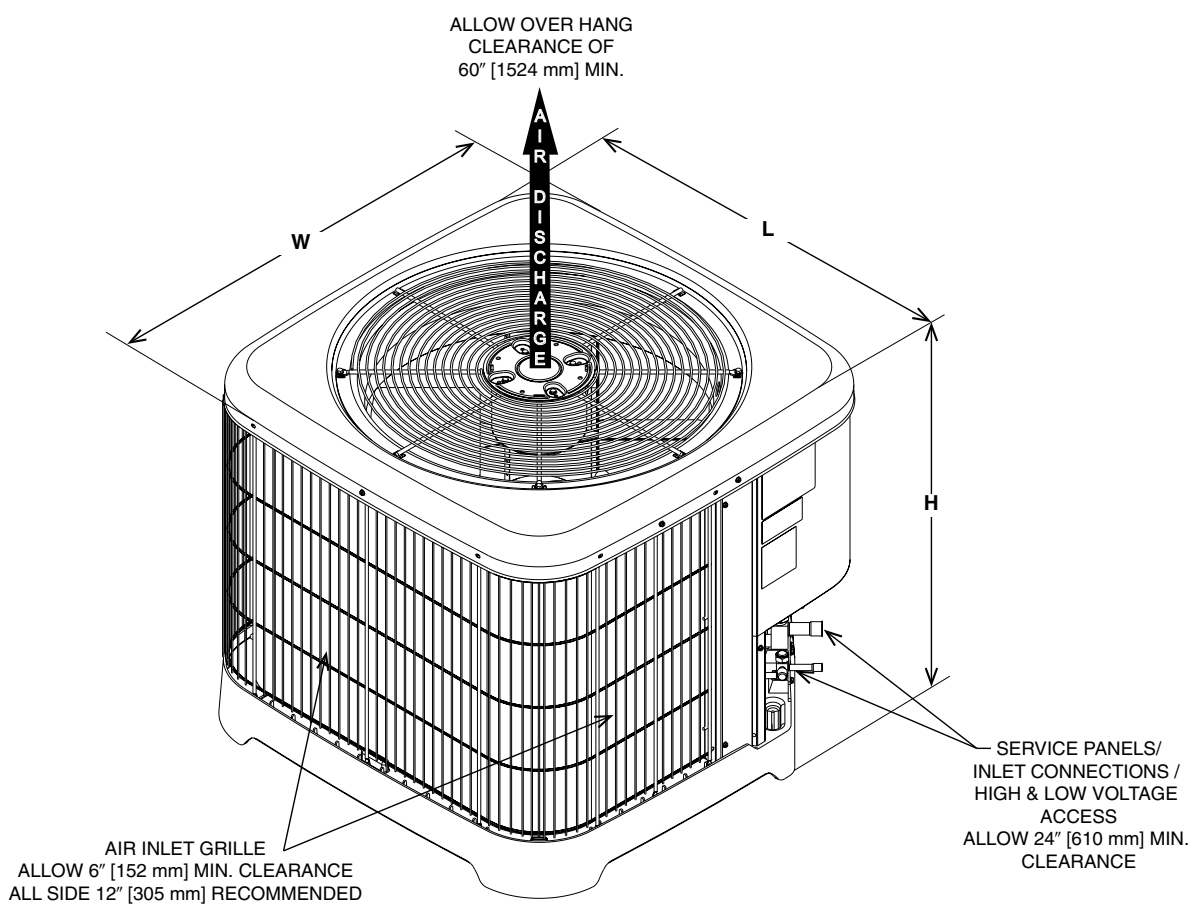

[ ] Designates Metric Conversions

ST-A1226-24-00

# CLEARANCES

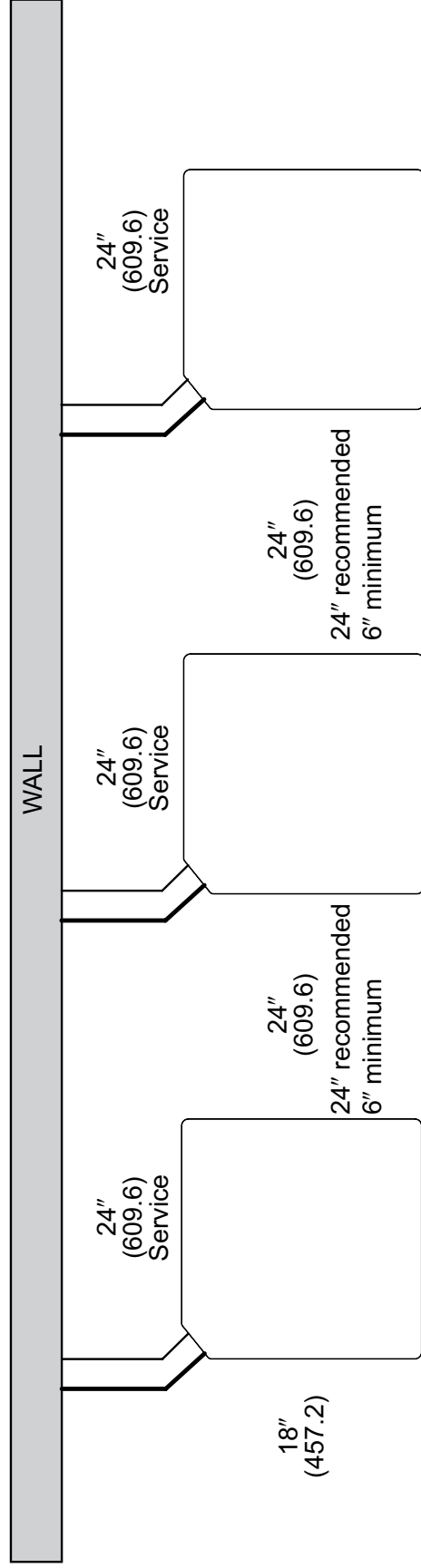
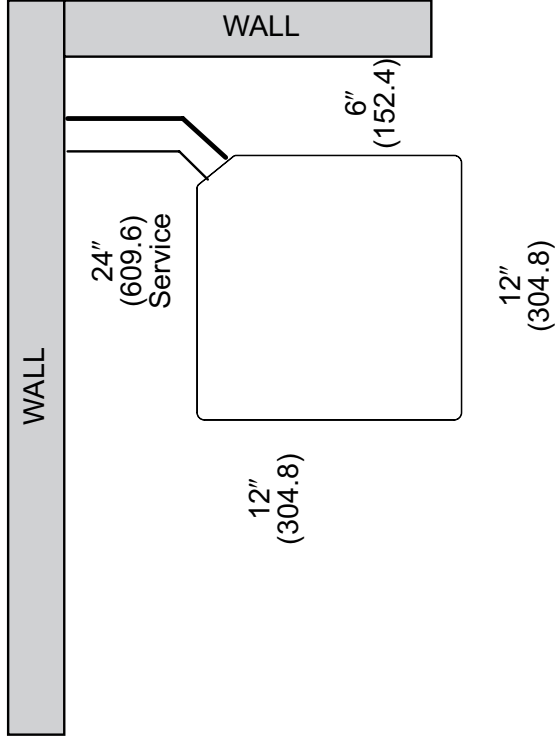
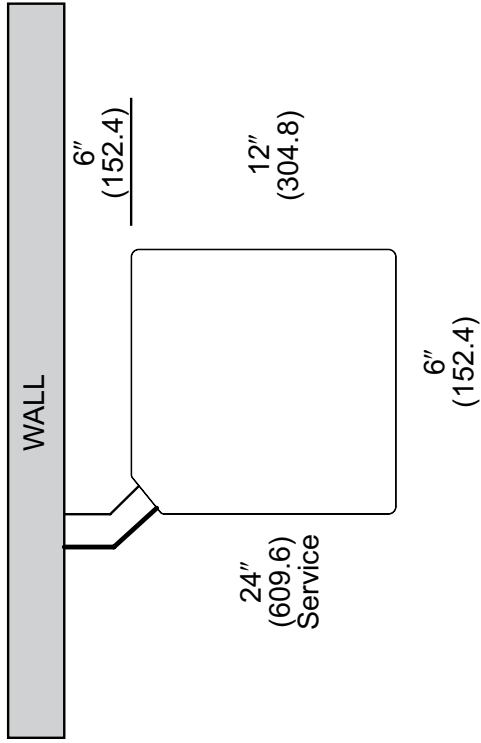

**NOTE: NUMBERS IN ( ) = mm**

**IMPORTANT:** When installing multiple units in an alcove, roof well or partially enclosed area, ensure there is adequate ventilation to prevent re-circulation of discharge air.



## Refrigerant Line Size Information

TWO-STAGE HEAT PUMPS												
UNIT SIZE	ALLOWABLE LIQUID LINE SIZE	ALLOWABLE SUCTION LINE SIZE	OUTDOOR UNIT ABOVE OR BELOW INDOOR UNIT EQUIVALENT LENGTH (FEET)									
			0-25	26-50	51-75	76-100	101-125	126-150	151-175	176-200	201-225	226-250
			MAXIMUM VERTICAL SEPARATION / CAPACITY MULTIPLIER									
1.5 Ton	1/4"	1/2"	25/1	50/0.98	66/0.97	47/0.95	27/0.94	7/0.92	0/0.91	0/0.89	0/0.88	0/0.87
	5/16"	1/2"	25/1	50/0.98	75/0.97	100/0.95	99/0.94	94/0.92	89/0.91	84/0.89	79/0.88	76/0.87
	3/8"	1/2"	25/1	50/0.98	75/0.97	100/0.95	117/0.94	116/0.92	115/0.91	113/0.89	111/0.88	110/0.87
	1/4"	5/8"	25/1	50/1	66/0.99	47/0.99	27/0.98	7/0.98	0/0.97	0/0.97	0/0.97	0/0.96
	5/16"	5/8"	25/1	50/1	75/0.99	100/0.99	99/0.98	94/0.98	89/0.97	84/0.97	79/0.97	76/0.96
	3/8"	5/8"	25/1	50/1	75/0.99	100/0.99	117/0.98	116/0.98	115/0.97	113/0.97	111/0.97	110/0.96
	1/4"	3/4"	25/1	50/1	66/1	47/1	27/0.99	7/0.99	0/0.99	0/0.99	0/0.99	0/0.99
	5/16"	3/4"	25/1	50/1	75/1	100/1	99/0.99	94/0.99	89/0.99	84/0.99	79/0.99	76/0.99
	3/8"	3/4"	25/1	50/1	75/1	100/1	117/0.99	116/0.99	115/0.99	113/0.99	111/0.99	110/0.99
2 Ton	1/4"	5/8"	25/1	50/0.99	33/0.98	3/0.98	0/0.97	0/0.96	0/0.95	0/0.95	0/0.94	0/0.94
	5/16"	5/8"	25/1	50/0.99	75/0.98	91/0.98	82/0.97	73/0.96	65/0.95	56/0.95	48/0.94	42/0.94
	3/8"	5/8"	25/1	50/0.99	75/0.98	100/0.98	110/0.97	107/0.96	104/0.95	101/0.95	98/0.94	95/0.94
	1/4"	3/4"	25/1	50/1	33/0.99	3/0.99	0/0.99	0/0.99	0/0.98	0/0.98	0/0.98	0/0.98
	5/16"	3/4"	25/1	50/1	75/0.99	91/0.99	82/0.99	73/0.99	65/0.98	56/0.98	48/0.98	42/0.98
2.5 Ton	3/8"	3/4"	25/1	50/1	75/0.99	100/0.99	110/0.99	107/0.99	104/0.98	101/0.98	98/0.98	95/0.98
	1/4"	5/8"	25/1	42/0.99	1/0.98	0/0.97	0/0.95	0/0.94	0/0.93	0/0.92	0/0.91	0/0.9
	5/16"	5/8"	25/1	50/0.99	75/0.98	73/0.97	60/0.95	47/0.94	34/0.93	22/0.92	10/0.91	1/0.9
	3/8"	5/8"	25/1	50/0.99	75/0.98	100/0.97	103/0.95	98/0.94	93/0.93	89/0.92	85/0.91	80/0.9
	1/4"	3/4"	25/1	42/1	1/0.99	0/0.99	0/0.98	0/0.98	0/0.97	0/0.97	0/0.97	0/0.96
	5/16"	3/4"	25/1	50/1	75/0.99	73/0.99	60/0.98	47/0.98	34/0.97	22/0.97	10/0.97	1/0.96
3 Ton	3/8"	3/4"	25/1	50/1	75/0.99	100/0.99	103/0.98	98/0.98	93/0.97	89/0.97	85/0.97	80/0.96
	5/16"	5/8"	25/1	50/0.98	71/0.97	53/0.95	35/0.93	17/0.92	0/0.9	0/0.89	0/0.87	0/0.87
	3/8"	5/8"	25/1	50/0.98	75/0.97	100/0.95	94/0.93	87/0.92	81/0.9	75/0.89	68/0.87	62/0.87
	5/16"	3/4"	25/1	50/0.99	71/0.99	53/0.98	35/0.98	17/0.97	0/0.96	0/0.96	0/0.95	0/0.95
	3/8"	3/4"	25/1	50/0.99	75/0.99	100/0.98	94/0.98	87/0.97	81/0.96	75/0.96	68/0.95	62/0.95
	1/2"	3/4"	25/1	50/0.99	75/0.99	100/0.98	119/0.98	118/0.97	116/0.96	115/0.96	114/0.95	113/0.95
	3/8"	7/8"	25/1	50/1	75/0.99	100/0.99	94/0.99	87/0.99	81/0.98	75/0.98	68/0.98	62/0.98
3.5 Ton	1/2"	7/8"	25/1	50/1	75/0.99	100/0.99	119/0.99	118/0.99	116/0.98	115/0.98	114/0.98	113/0.98
	3/8"	3/4"	25/1	50/0.99	75/0.98	92/0.98	83/0.97	75/0.96	67/0.95	59/0.94	50/0.94	42/0.93
	1/2"	3/4"	25/1	50/0.99	75/0.98	100/0.98	117/0.97	115/0.96	113/0.95	112/0.94	110/0.94	109/0.93
	3/8"	7/8"	25/1	50/1	75/0.99	92/0.99	83/0.99	75/0.98	67/0.98	59/0.98	50/0.97	42/0.97
4 Ton	1/2"	7/8"	25/1	50/1	75/0.99	100/0.99	117/0.99	115/0.98	113/0.98	112/0.98	110/0.97	109/0.97
	3/8"	3/4"	25/1	50/0.99	75/0.98	83/0.97	72/0.96	61/0.95	51/0.94	40/0.93	29/0.92	19/0.91
	1/2"	3/4"	25/1	50/0.99	75/0.98	100/0.97	114/0.96	112/0.95	110/0.94	108/0.93	106/0.92	105/0.91
	3/8"	7/8"	25/1	50/1	75/0.99	83/0.99	72/0.98	61/0.98	51/0.97	40/0.97	29/0.96	19/0.96
5 Ton	1/2"	7/8"	25/1	50/1	75/0.99	100/0.99	114/0.98	112/0.98	110/0.97	108/0.97	106/0.96	105/0.96
	3/8"	3/4"	25/1	50/0.98	75/0.97	61/0.95	45/0.94	29/0.92	13/0.9	0/0.89	0/0.87	0/0.86
	1/2"	3/4"	25/1	50/0.98	75/0.97	100/0.95	109/0.94	106/0.92	102/0.9	99/0.89	96/0.87	94/0.86
	3/8"	7/8"	25/1	50/0.99	75/0.99	61/0.98	45/0.97	29/0.97	13/0.96	0/0.95	0/0.95	0/0.94
5 Ton	1/2"	7/8"	25/1	50/0.99	75/0.99	100/0.98	109/0.97	106/0.97	102/0.96	99/0.95	96/0.95	94/0.94

**NOTES:**

- 1) Maximum Equivalent Line Length may not exceed 250'.
- 2) Maximum Actual Line Length may not exceed 200'.
- 3) Light Grey shaded areas are considered long line and may require accessories as recommended in Long Line Set Guide.
- 4) DO NOT use suction line traps in the suction riser as this adds additional unwanted pressure drop in the system.

## Refrigerant Line Size Information (Con't.)

TWO-STAGE HEAT PUMPS												
UNIT SIZE	ALLOWABLE LIQUID LINE SIZE	ALLOWABLE SUCTION LINE SIZE	OUTDOOR UNIT ABOVE OR BELOW INDOOR UNIT EQUIVALENT LENGTH (METERS)									
			0-8	8-15	16-23	23-30	31-38	38-46	46-53	54-61	61-69	69-76
			MAXIMUM VERTICAL SEPARATION / CAPACITY MULTIPLIER									
1.5 Ton	1/4"	1/2"	8/1	15/0.98	20/0.97	14/0.95	8/0.94	2/0.92	0/0.91	0/0.89	0/0.88	0/0.87
	5/16"	1/2"	8/1	15/0.98	23/0.97	30/0.95	30/0.94	29/0.92	27/0.91	26/0.89	24/0.88	23/0.87
	3/8"	1/2"	8/1	15/0.98	23/0.97	30/0.95	36/0.94	35/0.92	35/0.91	34/0.89	34/0.88	34/0.87
	1/4"	5/8"	8/1	15/1	20/0.99	14/0.99	8/0.98	2/0.98	0/0.97	0/0.97	0/0.97	0/0.96
	5/16"	5/8"	8/1	15/1	23/0.99	30/0.99	30/0.98	29/0.98	27/0.97	26/0.97	24/0.97	23/0.96
	3/8"	5/8"	8/1	15/1	23/0.99	30/0.99	36/0.98	35/0.98	35/0.97	34/0.97	34/0.97	34/0.96
	1/4"	3/4"	8/1	15/1	20/1	14/1	8/0.99	2/0.99	0/0.99	0/0.99	0/0.99	0/0.99
	5/16"	3/4"	8/1	15/1	23/1	30/1	30/0.99	29/0.99	27/0.99	26/0.99	24/0.99	23/0.99
	3/8"	3/4"	8/1	15/1	23/1	30/1	36/0.99	35/0.99	35/0.99	34/0.99	34/0.99	34/0.99
2 Ton	1/4"	5/8"	8/1	15/0.99	10/0.98	1/0.98	0/0.97	0/0.96	0/0.95	0/0.95	0/0.94	0/0.94
	5/16"	5/8"	8/1	15/0.99	23/0.98	28/0.98	25/0.97	22/0.96	20/0.95	17/0.95	15/0.94	13/0.94
	3/8"	5/8"	8/1	15/0.99	23/0.98	30/0.98	34/0.97	33/0.96	32/0.95	31/0.95	30/0.94	29/0.94
	1/4"	3/4"	8/1	15/1	10/0.99	1/0.99	0/0.99	0/0.99	0/0.98	0/0.98	0/0.98	0/0.98
	5/16"	3/4"	8/1	15/1	23/0.99	28/0.99	25/0.99	22/0.99	20/0.98	17/0.98	15/0.98	13/0.98
	3/8"	3/4"	8/1	15/1	23/0.99	30/0.99	34/0.99	33/0.99	32/0.98	31/0.98	30/0.98	29/0.98
2.5 Ton	1/4"	5/8"	8/1	13/0.99	0.3/0.98	0/0.97	0/0.95	0/0.94	0/0.93	0/0.92	0/0.91	0/0.9
	5/16"	5/8"	8/1	15/0.99	23/0.98	22/0.97	18/0.95	14/0.94	10/0.93	7/0.92	3/0.91	0.3/0.9
	3/8"	5/8"	8/1	15/0.99	23/0.98	30/0.97	31/0.95	30/0.94	28/0.93	27/0.92	26/0.91	24/0.9
	1/4"	3/4"	8/1	13/1	0.3/0.99	0/0.99	0/0.98	0/0.98	0/0.97	0/0.97	0/0.97	0/0.96
	5/16"	3/4"	8/1	15/1	23/0.99	22/0.99	18/0.98	14/0.98	10/0.97	7/0.97	3/0.97	0.3/0.96
	3/8"	3/4"	8/1	15/1	23/0.99	30/0.99	31/0.98	30/0.98	28/0.97	27/0.97	26/0.97	24/0.96
3 Ton	5/16"	5/8"	8/1	15/0.98	22/0.97	16/0.95	11/0.93	5/0.92	0/0.9	0/0.89	0/0.87	0/0.87
	3/8"	5/8"	8/1	15/0.98	23/0.97	30/0.95	29/0.93	27/0.92	25/0.9	23/0.89	21/0.87	19/0.87
	5/16"	3/4"	8/1	15/0.98	22/0.99	16/0.98	11/0.98	5/0.97	0/0.96	0/0.96	0/0.95	0/0.95
	3/8"	3/4"	8/1	15/0.98	23/0.99	30/0.98	29/0.98	27/0.97	25/0.96	23/0.96	21/0.95	19/0.95
	1/2"	3/4"	8/1	15/0.98	23/0.99	30/0.98	36/0.98	36/0.97	35/0.96	35/0.96	35/0.95	34/0.95
	3/8"	7/8"	8/1	15/1	23/0.99	30/0.99	29/0.99	27/0.99	25/0.98	23/0.98	21/0.98	19/0.98
	1/2"	7/8"	8/1	15/1	23/0.99	30/0.99	36/0.99	36/0.99	35/0.98	35/0.98	35/0.98	34/0.98
3.5 Ton	3/8"	3/4"	8/1	15/0.99	23/0.98	28/0.98	25/0.97	23/0.96	20/0.95	18/0.94	15/0.94	13/0.93
	1/2"	3/4"	8/1	15/0.99	23/0.98	30/0.98	36/0.97	35/0.96	34/0.95	34/0.94	34/0.94	33/0.93
	3/8"	7/8"	8/1	15/1	23/0.99	28/0.99	25/0.99	23/0.98	20/0.98	18/0.98	15/0.97	13/0.97
	1/2"	7/8"	8/1	15/1	23/0.99	30/0.99	36/0.99	35/0.98	34/0.98	34/0.98	34/0.97	33/0.97
4 Ton	3/8"	3/4"	8/1	15/0.99	23/0.98	25/0.97	22/0.96	19/0.95	16/0.94	12/0.93	9/0.92	6/0.91
	1/2"	3/4"	8/1	15/0.99	23/0.98	30/0.97	35/0.96	34/0.95	34/0.94	33/0.93	32/0.92	32/0.91
	3/8"	7/8"	8/1	15/1	23/0.99	25/0.99	22/0.98	19/0.98	16/0.97	12/0.97	9/0.96	6/0.96
	1/2"	7/8"	8/1	15/1	23/0.99	30/0.99	35/0.98	34/0.98	34/0.97	33/0.97	32/0.96	32/0.96
5 Ton	3/8"	3/4"	8/1	15/0.98	23/0.97	19/0.95	14/0.94	9/0.92	4/0.9	0/0.89	0/0.87	0/0.86
	1/2"	3/4"	8/1	15/0.98	23/0.97	30/0.95	33/0.94	32/0.92	31/0.9	30/0.89	29/0.87	29/0.86
	3/8"	7/8"	8/1	15/0.99	23/0.99	19/0.98	14/0.97	9/0.97	4/0.96	0/0.95	0/0.95	0/0.94
	1/2"	7/8"	8/1	15/0.99	23/0.99	30/0.98	33/0.97	32/0.97	31/0.96	30/0.95	29/0.95	29/0.94

**NOTES:**

- 1) Maximum Equivalent Line Length may not exceed 76 Meters.
- 2) Maximum Actual Line Length may not exceed 61 Meters.
- 3) Light Grey shaded areas are considered long line and may require accessories as recommended in Long Line Set Guide.
- 4) **DO NOT** use suction line traps in the suction riser as this adds additional unwanted pressure drop in the system.

## Performance Data @ AHRI Standard Conditions – Cooling

DESIGNATED TESTED COMBINATION (DTC)												
OUTDOOR UNIT	AIR HANDLER	TOTAL CAPACITY BTU/H [kW]	NET SENSIBLE BTU/H [kW]	NET LATENT BTU/H [kW]	SEER2	EER2	INDOOR CFM [L/S]	47 DEGREE HEATING CAPACITY BTU/H [KW]	47 DEGREE COP	17 DEGREE HEATING CAPACITY BTU/H [KW]	17 DEGREE COP	REGION IV HSPF2
SP14AY18AJ1	SH2CY2417STANN	17,100 [5.0]	13,100 [3.8]	4,000 [1.2]	14.3	9.0	625 [295.0]	16,600 [5.0]	3.30	10,100 [3.3]	2.40	7.5
SP14AY24AJ2	SH2CY2417STANN	22,800 [6.7]	17,500 [5.1]	5,300 [1.6]	14.3	9.0	775 [365.8]	22,800 [6.7]	3.60	14,000 [4.3]	2.50	7.5
SP14AY30AJ2	SH2CY3617STANN	28,600 [8.4]	21,900 [6.4]	6,700 [2.0]	14.3	9.0	950 [448.4]	28,000 [8.4]	3.40	16,000 [5.3]	2.40	7.5
SP14AY36AJ2	SH2CY3617STANN	34,200 [10.0]	26,200 [7.7]	8,000 [2.3]	14.3	9.0	1,050 [495.5]	33,600 [10.0]	3.40	22,200 [6.9]	2.50	7.5
SP14AY42AJ2	SH2CY4821STANN	40,000 [11.7]	30,700 [9.0]	9,300 [2.7]	14.3	9.0	1,300 [613.5]	39,500 [11.6]	3.60	24,800 [7.5]	2.60	7.5
SP14AY48AJ2	SH2CY4821STANN	45,500 [13.3]	34,900 [10.2]	10,600 [3.1]	14.3	9.0	1,450 [684.3]	44,000 [13.0]	3.40	27,500 [8.1]	2.50	7.5
SP14AY60AJ2	SH2CY6021STANA	54,000 [15.8]	41,400 [12.1]	12,600 [3.7]	14.3	9.0	1,650 [778.7]	54,000 [16.3]	3.50	32,000 [10.0]	2.50	7.5
SP14AY36AC2	SH2CY3617STANN	34,200 [10.0]	26,200 [7.7]	8,000 [2.3]	14.3	9.0	1,050 [495.5]	33,600 [10.0]	3.40	22,200 [6.9]	2.50	7.5
SP14AY42AC2	SH2CY4821STANN	40,000 [11.7]	30,700 [9.0]	9,300 [2.7]	14.3	9.0	1,300 [613.5]	39,500 [11.6]	3.60	24,800 [7.5]	2.60	7.5
SP14AY48AC2	SH2CY4821STANN	45,500 [13.3]	34,900 [10.2]	10,600 [3.1]	14.3	9.0	1,450 [684.3]	44,000 [13.0]	3.40	27,500 [8.1]	2.50	7.5
SP14AY60AC2	SH2CY6021STANA	54,000 [15.8]	41,400 [12.1]	12,600 [3.7]	14.3	9.0	1,650 [778.7]	54,000 [16.3]	3.50	32,000 [10.0]	2.50	7.5
SP14AY36AD2	SH2CY3617STANN	34,200 [10.0]	26,200 [7.7]	8,000 [2.3]	14.3	9.0	1,050 [495.5]	33,600 [10.0]	3.40	22,200 [6.9]	2.50	7.5
SP14AY42AD2	SH2CY4821STANN	40,000 [11.7]	30,700 [9.0]	9,300 [2.7]	14.3	9.0	1,300 [613.5]	39,500 [11.6]	3.60	24,800 [7.5]	2.60	7.5
SP14AY48AD2	SH2CY4821STANN	45,500 [13.3]	34,900 [10.2]	10,600 [3.1]	14.3	9.0	1,450 [684.3]	44,000 [13.0]	3.40	27,500 [8.1]	2.50	7.5
SP14AY60AD2	SH2CY6021STANA	54,000 [15.8]	41,400 [12.1]	12,600 [3.7]	14.3	9.0	1,650 [778.7]	54,000 [16.3]	3.50	32,000 [10.0]	2.50	7.5

**NOTE:** This data includes DTC (Designated Test Combination) ratings and is for reference purposes only. A full listing of official ratings and system match-ups, along with downloadable certificates, will be accessible from the AHRI website: [www.ahridirectory.org](http://www.ahridirectory.org) later this year.

[ ] Designates Metric Conversions



**GENERAL TERMS OF LIMITED WARRANTY\***

Russell® By Rheem will furnish a replacement for any part of this product which fails in normal use and service within the applicable period stated, in accordance with the terms of the limited warranty.

**\*For complete details of the Limited and Conditional Warranties, including applicable terms and conditions, contact your local contractor or the Manufacturer for a copy of the product warranty certificate.**

Conditional Parts  
(Registration Required)..... Ten (10) Years

**Before proceeding with installation, refer to installation instructions packaged with each model, as well as complying with all Federal, State, Provincial, and Local codes, regulations, and practices.**

© 2024 Rheem Manufacturing Company. Russell By Rheem trademarks owned by Rheem Manufacturing Company.  
*In keeping with its policy of continuous progress and product improvement, Russell by Rheem reserves the right to make changes without notice.*

5600 Old Greenwood Road  
Fort Smith, Arkansas 72908 • [www.russellbyrheem.com](http://www.russellbyrheem.com)