

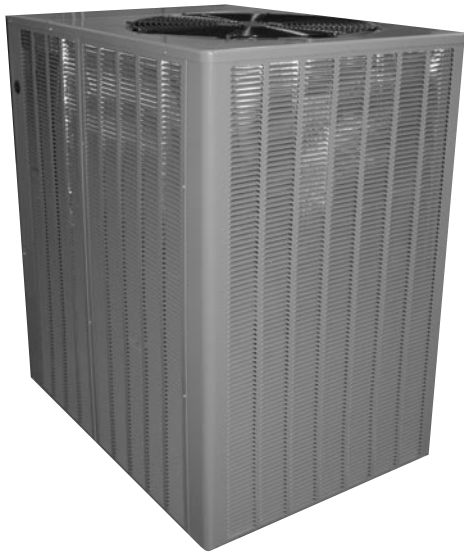

# MODEL: RPCL Heat Pump

FORM NO. PRR-819 REV. 3

## Russell® By Rheem Heat Pumps



### RPCL

• Nominal Size 7.5 & 10 Ton [26 & 35 kW]



## TABLE OF CONTENTS

Standard Unit Features .....	3-7
Model Number Identification .....	8
Selection Procedure .....	9
Unit Dimensions .....	10-11
Electrical/Physical Data .....	12
Performance Data .....	13-17
General Installation .....	18
Piping Recommendation .....	19-20
Sequence of Operation .....	21
Guide Specifications .....	22
Limited Warranty .....	23

## WHY USE AN AIR COOLED REMOTE HEAT PUMP SYSTEM?

- The size ranges offered by Russell® By Rheem allow you to mix or match components to meet actual job requirements, thus eliminating the need to use oversized or undersized equipment. Equipment sized to meet the actual load will provide better operating economy, better humidity control, and longer equipment life.
- With an air cooled system, you have no water or sewer connections to make, and no troublesome and costly water treatment problems.
- Since the Remote Heat Pump unit is located outside the building, and the low profile air handling unit can be installed in the drop ceiling or in the conditioned space, you will not need a separate equipment room which takes up valuable building space.
- Remote mounting of the already quiet heat pump unit keeps the compressor and condenser fan noise outside, and the vertical discharge fans carry the sound up and away from the surrounding area.
- Because of the simple design of the Russell® By Rheem Remote Heat Pump unit, installation is quick and simple, and very little maintenance is required.
- Energy Efficiency Ratings (EER's) to 11.0!

## STANDARD UNIT FEATURES

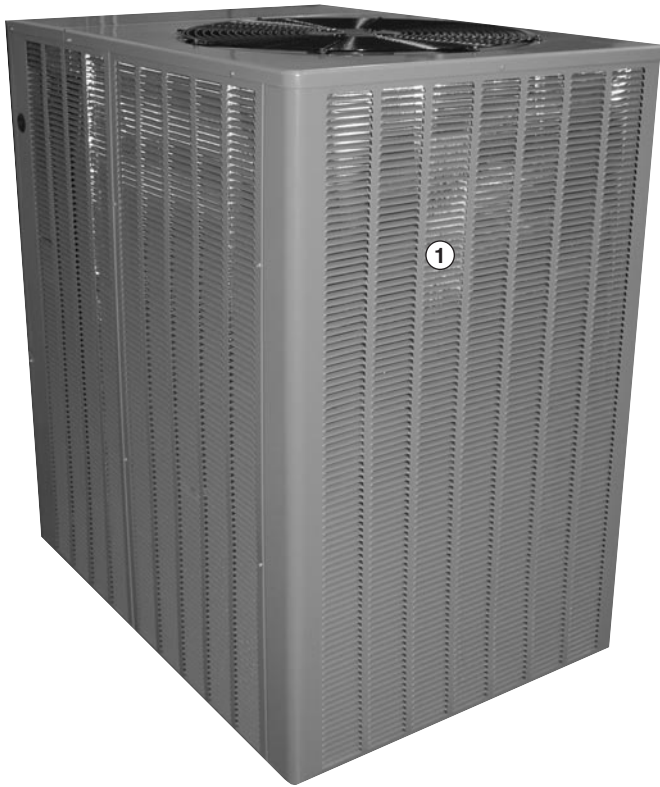

## 7.5 TON FEATURES AND BENEFITS

- 1. CABINET**—All access panels can be opened or removed without affecting the structural strength of the unit. Stamped louvered panels offer 100% protection for the condenser coil.
- 2. EQUIPMENT GROUND**— Lug for field connection of ground wire.
- 3. CONTACTOR**—The contactor is an electrical switch which operates the compressor and outdoor fans. Its 24 volt coil is activated on a call for cooling or heating.

## CONTROL BOX

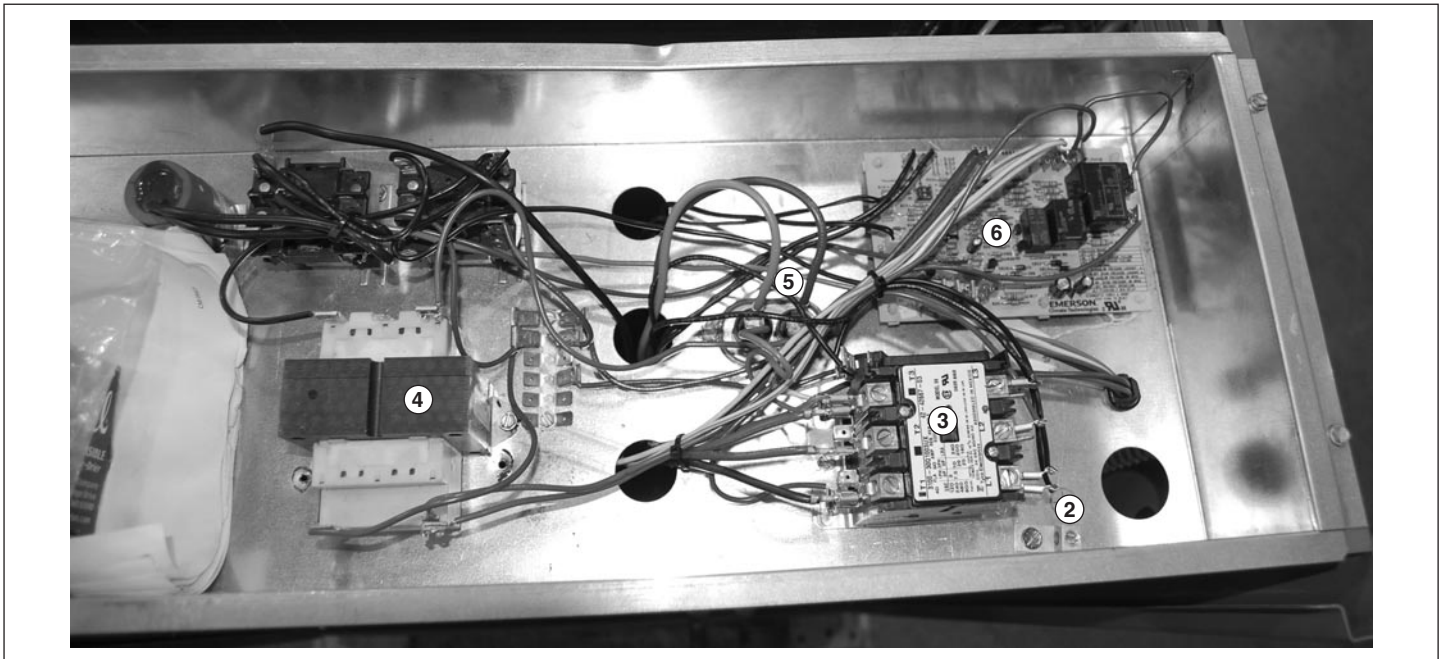

- 4. TRANSFORMER**—75 VA step-down type, from Line to 24 volts with resettable circuit breaker.
- 5. CAPACITOR**—Help provide starting torque necessary to boost the condenser fan motors to operating speed by directing their stored energy to the starter winding in step with the running winding.
- 6. DEMAND DEFROST CONTROL**—Used when unit is in heating mode to defrost outdoor coil.
- 7. AUTO-RESET HIGH PRESSURE CONTROL, AND AUTO-RESET LOW PRESSURE CONTROL**—To provide compressor protection under abnormally high head pressure conditions (outdoor fan failure, restriction, dirty coil, etc.) or abnormally low suction pressure conditions (restrictions, TEV failure, loss of charge, indoor blower failure, etc.) while eliminating nuisance tripping sometimes experienced with conventional control systems.

## STANDARD UNIT FEATURES (con't.)

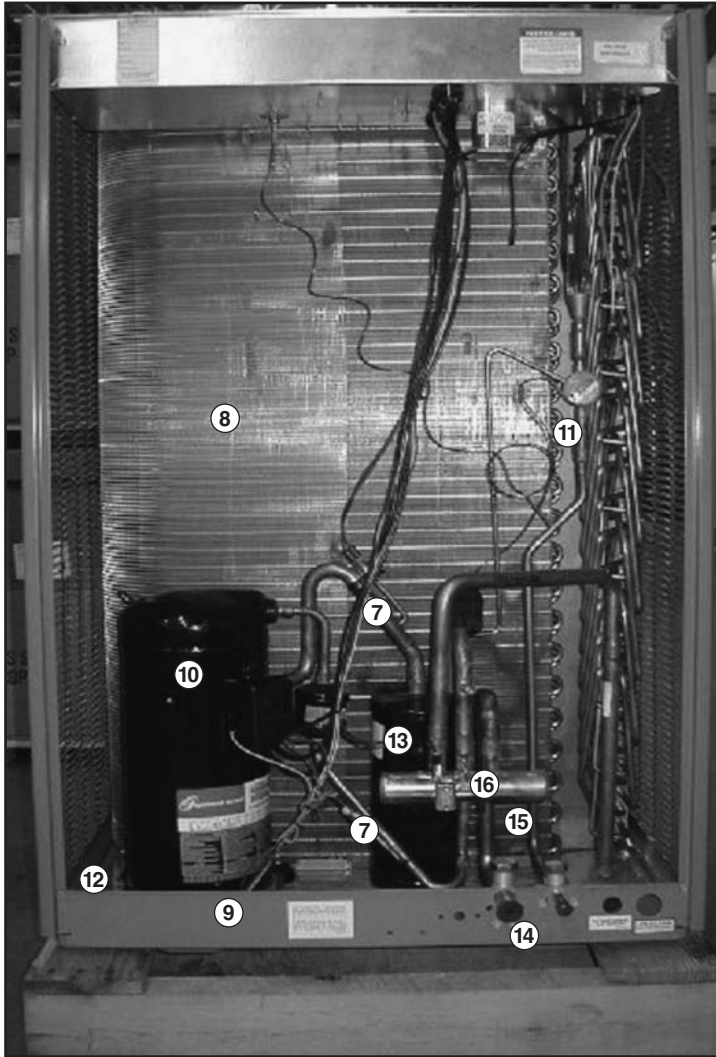

**8. COIL**—Constructed with copper tubes and aluminum fins mechanically bonded to tubes for maximum heat transfer capabilities. All coil assemblies are leak tested up to 550 PSIG (3792 kPa) internal pressure.

**SERVICE ACCESS**—Control box with separate line and control voltages, as well as compressor and other refrigerant controls are accessible through access panels. An electrical access cover may be opened or removed without affecting normal operation of the unit. Condenser fan motors are equipped with molded plugs for easy removal. Louver panels and end access panel can be removed for coil cleaning.

**9. BASE PAN**—Galvanized steel with weather-resistant baked enamel finish.

**10. COMPRESSOR**—The Scroll Compressor is hermetically sealed with internal high temperature protection, and durable insulation on motor windings. The entire compressor is mounted on rubber grommets to reduce vibration and noise.

**11. TX VALVE**—Used when unit is in heating mode and outdoor coil functions as evaporator.

**12. CRANKCASE HEATER**—Minimizes refrigerant migration to compressor sump.

**13. SUCTION LINE ACCUMULATOR**—To prevent liquid slugging of compressor.

**14. REFRIGERANT CONNECTIONS**—All field sweat joints are made external of the unit and are located close to the ground for a neat looking installation.

**15. SERVICE VALVES**—Standard on liquid line and vapor line.

**16. REVERSING VALVE**—Sized for maximum capacity and efficiency, 24V coil, energized in heating.

## STANDARD UNIT FEATURES



## 10 TON FEATURES AND BENEFITS

1. **BASE RAILS**—Commercial grade base rails for handling any rigging.
2. **CABINET**—Galvanized steel with powder coat paint finish. The powder coat paint finish is high gloss, durable and capable of withstanding a 1000-hour salt spray test per ASTM B 117. All access panels can be opened or removed without affecting the structural strength of the unit. Stamped louvered panels offer 100% protection for the condenser coil.

## CONTROL BOX

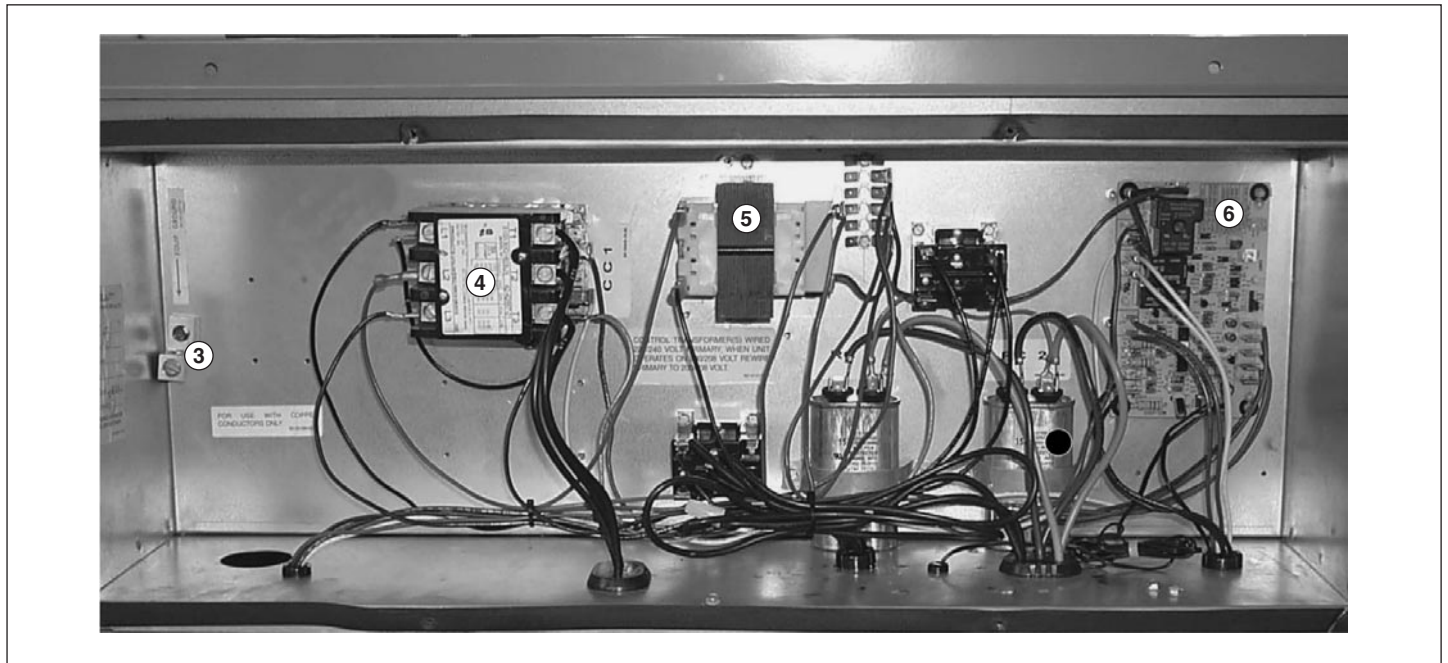

3. **EQUIPMENT GROUND**—Lug for field connection of ground wire.
4. **CONTACTOR**—The contactor is an electrical switch which operates the compressor and outdoor fans. Its 24 volt coil is activated on a call for cooling or heating.
5. **TRANSFORMER**—75 VA step-down type, from Line to 24 volts with resettable circuit breaker.
6. **DEMAND DEFROST CONTROL**—Used when unit is in heating mode to defrost outdoor coil.
7. **COILS**—Constructed with copper tubes and aluminum fins mechanically bonded to tubes for maximum heat transfer capabilities. All coil assemblies are leak tested up to 550 PSIG [3792 kPa] internal pressure.

## STANDARD UNIT FEATURES (con't.)

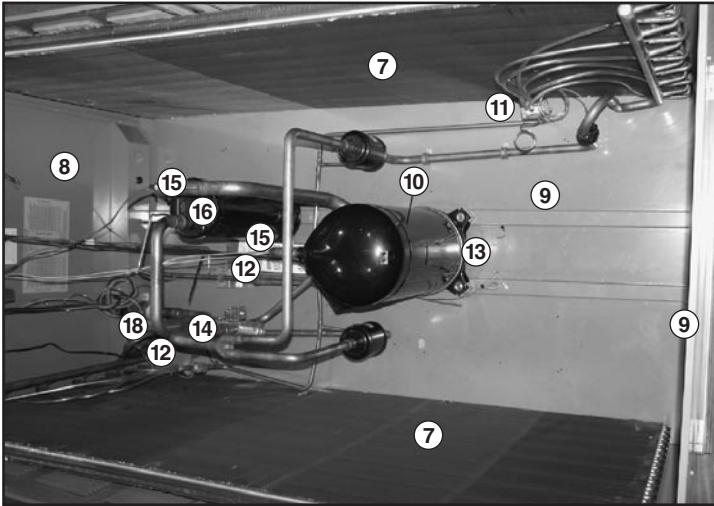

8. **SERVICE ACCESS**—Control box with separate line and control voltages, as well as compressor and other refrigerant controls are accessible through access panels. An electrical access cover may be opened or removed without affecting normal operation of the unit. Condenser fan motors are equipped with molded plugs for easy removal. Louver panels and end access panel can be removed for coil cleaning.
9. **BASE PAN**—Galvanized steel with powder coat paint finish.
10. **COMPRESSOR**—The Scroll Compressor is hermetically sealed with internal high temperature protection, and durable insulation on motor windings. The entire compressor is mounted on rubber grommets to reduce vibration and noise.
11. **TX VALVE**—Used when unit is in heating mode and outdoor coil functions as evaporator.
12. **FILTER DRIER**—Field installed in liquid line. Supplied from factory.
13. **CRANKCASE HEATER**—Minimizes refrigerant migration to compressor sump.
14. **REVERSING VALVE**—Sized for maximum capacity and efficiency, 24V coil, energized in heating.
15. **AUTO-RESET HIGH PRESSURE CONTROL, AND AUTO-RESET LOW PRESSURE CONTROL**—To provide compressor protection under abnormally high head pressure conditions (outdoor fan failure, restriction, dirty coil, etc.) or abnormally low suction pressure conditions (restrictions, TEV failure, loss of charge, indoor blower failure, etc.) while eliminating nuisance tripping sometimes experienced with conventional control systems.
16. **SUCTION LINE ACCUMULATOR**—To prevent liquid slugging of compressor.
17. **REFRIGERANT CONNECTIONS**—All field sweat joints are made external of the unit and are located close to the ground for a neat looking installation.
18. **SERVICE VALVE**—Standard on liquid line, and vapor line.
19. **CONDENSER FAN MOTORS**—Brushless permanent magnet motor.

## GENERAL INSTALLATION

The condensing unit should be installed outdoors. It should be located as near as possible to the evaporator section to keep connecting refrigerant tubing lengths to a minimum. The unit must be installed to allow a free air flow to the condenser coils.

## MODEL IDENTIFICATION

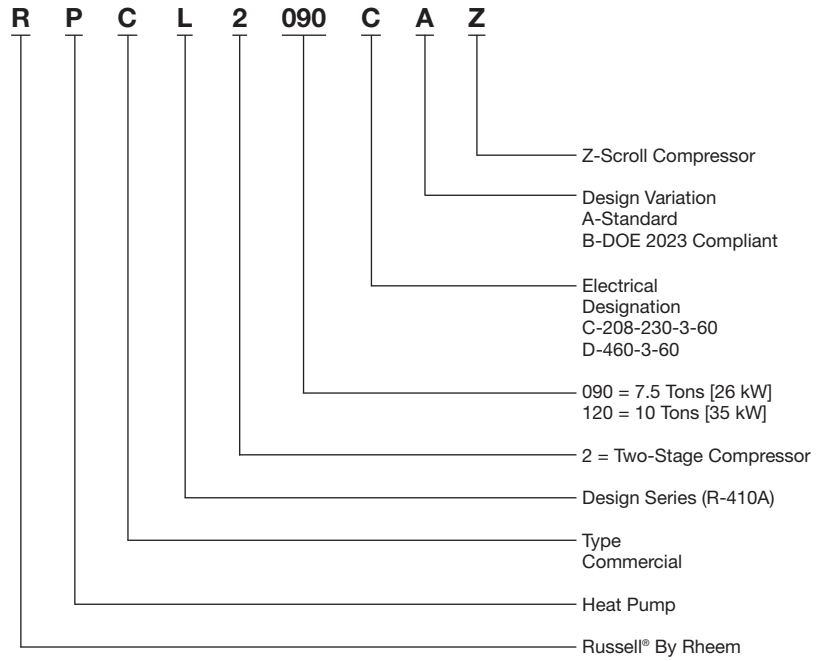

[ ] Designates Metric Conversions



## SELECTION PROCEDURE

To select an RPCL Heat Pump unit to meet a job requirement, follow this procedure.

### 1. DETERMINE COOLING AND HEATING REQUIREMENTS AND SPECIFIC OPERATING CONDITIONS FROM PLANS AND SPECS.

Example: Total cooling capacity—	84,000 BTUH [24.61 kW]
Sensible cooling capacity—	68,000 BTUH [19.92 kW]
Heating capacity—	120,000 BTUH [35.16 kW]
*Condenser Entering Air—	95°F [35°C] DB
*Evaporator Mixed Air Entering	78°F [26°C] DB; 65°F [18°C] WB
*Indoor Air Flow (vertical)	3000 CFM [1416 L/s]
*External Static Pressure	.5 in. WG
Available Power	240 V, 3 PH

### 2. SELECT UNIT TO MEET COOLING REQUIREMENTS.

Since total cooling is within the range of a nominal 7.5 ton [26.4 kW] unit, enter cooling performance table at 95°F [35°C] DB condenser inlet air. Interpolate between 63°F [2°C] and 67°F [19°C] to determine total and sensible capacity and power input for 65°F [18°C] WB evap inlet air at 3200 CFM [1510 L/s] indoor air flow (table basis):

$$\begin{aligned} \text{Total Capacity} &= 85,150 \text{ BTUH [25.0 kW]} \\ \text{Sensible Capacity} &= 73,850 \text{ BTUH [23.0 kW]} \\ \text{Power Input (Compressor and Cond. Fans)} &= 6,750 \text{ Watts} \end{aligned}$$

Use formula in note ① on the cooling performance table to determine sensible capacity at 78°F [26°C] DB evaporator entering air:

$$\text{Sensible Capacity} = 67,250 \text{ BTUH [19.7 kW]}$$

### 3. CORRECT CAPACITIES OF STEP 2 FOR ACTUAL AIR FLOW.

Select factors from airflow correction table at 3000 CFM [1416 L/s] and apply to data obtained in step 2 to obtain gross capacity:

$$\begin{aligned} \text{Total Capacity} &= 85,150 \times .99 = 84,299 \text{ BTUH [24.7 kW]} \\ \text{Sensible Capacity} &= 73,850 \times .97 = 71,634 \text{ BTUH [21.0 kW]} \\ \text{Power Input} &= 6,750 \times 1.00 = 6,750 \text{ Watts} \end{aligned}$$

These are Gross Capacities, not corrected for blower motor heat or power.

### 4. DETERMINE BLOWER SPEED AND WATTS TO MEET SYSTEM DESIGN.

In the “Commercial Air Handler Specification Sheet” follow the bold line example on the “Blower Performance Curve – 10 ton (wet coil)”. Enter the graph at 3000 CFM [1416 L/s]. Determine which “number of turns” line is closest to the intersection of 0.5 IN [.12 kPa] static and 3000 CFM [1416 L/s]. In this case 4 turns is the closest. Continue following the 3000 CFM line to the next intersection of 4 turns. From this intersection draw a line to the right to determine the watts.

$$\text{WATTS} = 950$$

### 5. CALCULATE INDOOR BLOWER BTUH HEAT EFFECT FROM MOTOR WATTS, STEP 4.

$$\text{HEAT} = 950 \times 3.412 = 3,240 \text{ BTUH}$$

### 6. CALCULATE NET COOLING CAPACITIES, EQUAL TO GROSS CAPACITY, STEP 3, MINUS INDOOR BLOWER MOTOR HEAT.

$$\begin{aligned} \text{Net Total Capacity} &= 84,299 - 3,240 = 81,059 \text{ BTUH [23.76 kW]} \\ \text{Net Sensible Capacity} &= 71,634 - 3,240 = 68,394 \text{ BTUH [20.00 kW]} \end{aligned}$$

### 7. CALCULATE UNIT INPUT AND JOB EER.

$$\text{Total Power Input} = 6,750 \text{ (step 3)} + 950 \text{ (step 4)} = 7,700 \text{ Watts}$$

$$\text{EER} = \frac{\text{Net Total BTUH [kW]} \text{ (step 6)}}{\text{Power Input, Watts (above)}} = \frac{81,059}{7700} = 10.5$$

### 8. SELECT UNIT HEATING CAPACITY.

In the “Commercial Air Handler Specification Sheet” turn to the “electrical heater kit characteristics table,” find a heater kit that is compatible with a 7.5 ton unit that has minimum of 120,000 BTUH. The RXHE-DE040CA [40 kW] has a capacity of 136,500 BTUH at 240 V.

\*NOTE: These operating conditions are typical of a commercial application in a 95°F/79°F [35°C/26°C] design area with indoor design of 76°F [24°C] DB and 50% RH and 10% ventilation air, with the unit mounted and centered on the zone it conditions by ducts.

[ ] Designates Metric Conversions

## UNIT DIMENSIONS AND WEIGHTS 7.5 TON [26 kW]

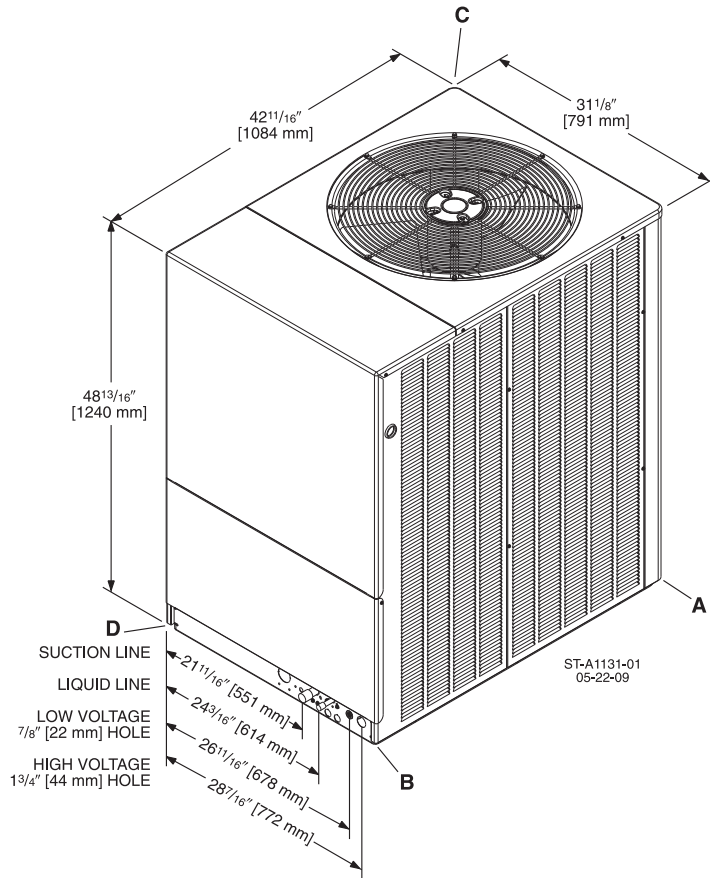

### 7.5 TON [26 kW]

CORNER WEIGHTS (LBS.) [kg]

MODEL	TOTAL WEIGHT LBS. [kg]	CORNER WEIGHTS, LBS. [kg]			
		A	B	C	D
RPCL2090	428	75	107	79	167

[ ] Designates Metric Conversions

## UNIT DIMENSIONS AND WEIGHTS 10 TON [35 kW]

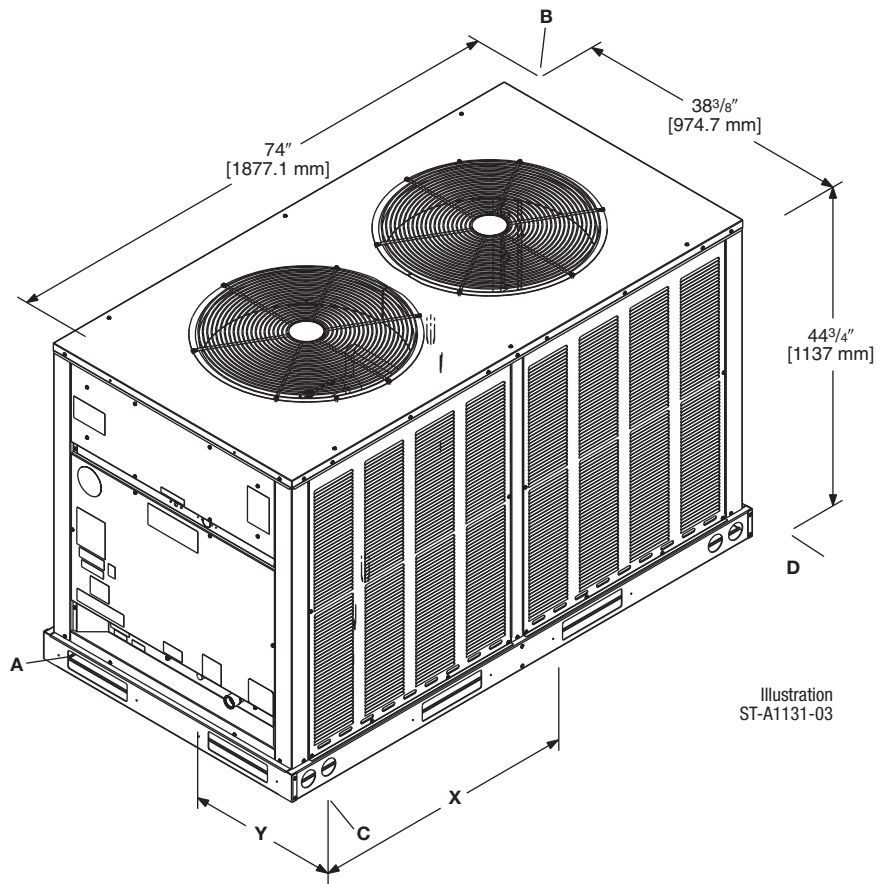

Illustration  
ST-A1131-03

### 10 TON [35 kW]

#### CORNER WEIGHTS

MODEL	TOTAL WEIGHT LBS. [kg]	CORNER WEIGHTS, LBS. [kg]			
		A	B	C	D
(-)PCL2120	642	167	154	167	154

[ ] Designates Metric Conversions

Electrical and Physical Data

Model Number (-)RPCL2	ELECTRICAL						PHYSICAL								
	Phase Frequency (Hz) Voltage (Volts)	Number of Compressors	Compressor		Number of Fans	Fan Motor Full Load Amperes (FLA) each	Minimum Circuit Ampacity Amperes	Fuse or HACR Circuit Breaker		Outdoor Coil		Refrig. Per Circuit Oz. [g]	Weight		
			Rated Load Amperes (RLA) each	Locked Rotor Amperes (LRA) each				Minimum Amperes	Maximum Amperes	Face Area Sq. Ft. [m <sup>2</sup> ]	No. Rows		CFM [L/s]	Net Lbs. [kg]	Shipping Lbs. [kg]
Rev. 9/18/2020															
090C	3-60-208/230	1	22.4	164	1	5.3	39	50	60	34.50 [3.21]	2	5000 [2360]	350.6 [9939]	389 [176.4]	439 [199.1]
090D	3-60-460	1	12.0	94	1	2.5	18	25	25	34.50 [3.21]	2	5000 [2360]	350.6 [9939]	389 [176.4]	439 [199.1]
120C	3-60-208/230	1	33.3	240	2	5.3	53	70	80	32.88 [3.05]	2	7400 [3492]	500.5 [14189]	600 [272.0]	640 [290.3]
120D	3-60-460	1	14.8	130	2	2.5	24	30	35	32.88 [3.05]	2	7400 [3492]	500.5 [14189]	600 [272.0]	640 [290.3]

[ ] Designates Metric Conversions

## PERFORMANCE DATA @ AHRI STANDARD CONDITIONS

MODEL NUMBERS		80°F [26.5°C] DB 67°F [19.5°C] WB INDOOR AIR 95°F [35°C] DB OUTDOOR AIR						RATED INDOOR CFM [L/s]
OUTDOOR UNIT RPCL-	INDOOR COIL AND/OR AIR HANDLER	TOTAL CAPACITY BTU/H [kW]	NET SENSIBLE BTU/H [kW]	NET LATENT BTU/H [kW]	EER	IEER	COP @47°	
RPCL2090CA	RHCLP2090CA	85000 [24.9]	58200 [17.1]	26800 [7.8]	11.0	12.2	3.3	2650
RPCL2120CA	RHCLP2120CA	113000 [33.1]	83100 [24.3]	29900 [8.8]	11.0	12.2	3.3	3400
RPCL2090CB	RHCLP2090CB	85000 [24.9]	58200 [17.1]	26800 [7.8]	11.0	14.1	3.4	2650
RPCL2120CB	RHCLP2120CB	113000 [33.1]	83100 [24.3]	29900 [8.8]	11.0	14.1	3.4	3400

[ ] Designates Metric Conversions

**COOLING PERFORMANCE DATA – RPCL2090+RHCLP2090**

wBE		ENTERING INDOOR AIR @ 80°F [26.7°C] dbE ①										61°F [16.1°C]		59°F [15.0°C]		
		CFM [L/s]		71°F [21.7°C]		67°F [19.4°C]		63°F [17.2°C]		61°F [16.1°C]						59°F [15.0°C]
DR ①		3600 [1699]	3225 [1522]	2400 [1133]	3600 [1699]	3225 [1522]	2400 [1133]	3600 [1699]	3225 [1522]	2400 [1133]	3600 [1699]	3225 [1522]	2400 [1133]	3600 [1699]	3225 [1522]	2400 [1133]
75 [23.9]		0.21	0.19	0.12	0.21	0.19	0.12	0.21	0.19	0.12	0.21	0.19	0.12	0.21	0.19	0.12
Sens BTUH [KW]		104.3 [30.6]	102.2 [29.9]	97.4 [28.5]	97.0 [28.4]	95.0 [27.8]	90.5 [26.5]	86.3 [25.3]	84.5 [24.8]	80.6 [23.6]	79.4 [23.3]	77.7 [22.8]	74.1 [21.7]	71.1 [20.8]	69.7 [20.4]	66.4 [19.5]
Power		66.6 [19.5]	63.1 [18.5]	55.6 [16.3]	73.7 [21.6]	69.9 [20.5]	61.5 [18.0]	71.6 [21.0]	66.0 [19.9]	59.8 [17.5]	66.8 [19.6]	63.4 [18.6]	55.8 [16.4]	59.3 [17.4]	56.2 [16.5]	49.5 [14.5]
80 [26.7]		7.2	7.1	6.9	6.6	6.6	6.4	6.1	6.0	5.9	5.8	5.7	5.6	5.5	5.5	5.3
Total BTUH [KW]		102.5 [30.0]	100.4 [29.4]	95.7 [28.0]	95.1 [27.9]	93.1 [27.3]	88.8 [26.0]	84.4 [24.7]	82.7 [24.2]	78.8 [23.1]	77.5 [22.7]	75.9 [22.2]	72.4 [21.2]	69.3 [20.3]	67.9 [19.9]	64.7 [19.0]
Sens BTUH [KW]		66.0 [19.3]	62.6 [18.3]	55.1 [16.2]	73.1 [21.4]	69.4 [20.3]	61.1 [17.9]	71.1 [20.8]	67.4 [19.8]	59.4 [17.4]	66.3 [19.4]	62.9 [18.4]	55.4 [16.2]	58.7 [17.2]	55.7 [16.3]	49.1 [14.4]
Power		7.4	7.3	7.2	6.9	6.8	6.6	6.3	6.2	6.1	6.0	6.0	5.8	5.8	5.7	5.6
85 [29.4]		7.7	7.6	7.5	7.2	7.1	6.9	6.6	6.5	6.4	6.3	6.3	6.1	6.0	6.0	5.8
Total BTUH [KW]		100.3 [29.4]	98.2 [28.8]	93.7 [27.4]	92.9 [27.2]	91.0 [26.7]	86.8 [25.4]	82.3 [24.1]	80.6 [23.6]	76.8 [22.5]	75.3 [22.1]	73.8 [21.6]	70.4 [20.6]	67.1 [19.7]	65.7 [19.3]	62.7 [18.4]
Sens BTUH [KW]		65.2 [19.1]	61.8 [18.1]	54.4 [16.0]	72.3 [21.2]	68.6 [20.1]	60.4 [17.7]	70.3 [20.6]	66.7 [19.5]	58.7 [17.2]	65.5 [19.2]	62.1 [18.2]	54.7 [16.0]	57.9 [17.0]	54.9 [16.1]	48.4 [14.2]
Power		7.7	7.6	7.5	7.2	7.1	6.9	6.6	6.5	6.4	6.3	6.3	6.1	6.0	6.0	5.8
90 [32.2]		8.0	8.0	7.8	7.5	7.4	7.3	6.9	6.9	6.7	6.7	6.6	6.4	6.4	6.3	6.2
Total BTUH [KW]		97.8 [28.7]	95.8 [28.1]	91.3 [26.8]	90.4 [26.5]	88.6 [26.0]	84.5 [24.7]	79.8 [23.4]	78.1 [22.9]	74.5 [21.8]	72.9 [21.3]	71.3 [20.9]	68.0 [19.9]	64.6 [18.9]	63.3 [18.5]	60.3 [17.7]
Sens BTUH [KW]		64.0 [18.8]	60.7 [17.8]	53.5 [15.7]	71.2 [20.9]	67.5 [19.8]	59.4 [17.4]	69.1 [20.3]	65.6 [19.2]	57.7 [16.9]	64.3 [18.9]	61.0 [17.9]	53.7 [15.7]	56.8 [16.6]	53.8 [15.8]	47.4 [13.9]
Power		8.0	8.0	7.8	7.5	7.4	7.3	6.9	6.9	6.7	6.7	6.6	6.4	6.4	6.3	6.2
95 [35]		8.4	8.4	8.2	7.9	7.8	7.6	7.3	7.3	7.1	7.1	7.0	6.8	6.8	6.7	6.6
Total BTUH [KW]		95.0 [27.8]	93.0 [27.3]	88.7 [26.0]	87.6 [25.7]	85.8 [25.2]	81.8 [24.0]	77.0 [22.6]	75.4 [22.1]	71.9 [21.1]	70.1 [20.5]	68.6 [20.1]	65.4 [19.2]	61.8 [18.1]	60.5 [17.7]	57.7 [16.9]
Sens BTUH [KW]		62.6 [18.3]	59.4 [17.4]	52.3 [15.3]	69.7 [20.4]	66.1 [19.4]	58.2 [17.1]	67.7 [19.8]	64.2 [18.8]	56.5 [16.6]	62.9 [18.4]	59.7 [17.5]	52.5 [15.4]	55.3 [15.7]	52.5 [15.4]	46.2 [13.5]
Power		8.4	8.4	8.2	7.9	7.8	7.6	7.3	7.3	7.1	7.1	7.0	6.8	6.8	6.7	6.6
100 [37.8]		8.9	8.8	8.6	8.3	8.2	8.0	8.2	8.2	8.0	8.0	7.9	7.7	7.7	7.6	7.0
Total BTUH [KW]		91.9 [26.9]	90.0 [26.4]	85.8 [25.1]	84.5 [24.8]	82.8 [24.3]	78.9 [23.1]	73.9 [21.6]	72.3 [21.2]	69.0 [20.2]	66.9 [19.6]	65.5 [19.2]	62.5 [18.3]	58.7 [17.2]	57.5 [16.8]	54.8 [16.1]
Sens BTUH [KW]		60.9 [17.8]	57.7 [16.9]	50.8 [14.9]	68.0 [19.9]	64.5 [18.9]	56.8 [16.6]	66.0 [19.3]	62.6 [18.3]	55.1 [16.1]	61.2 [17.9]	58.0 [17.0]	51.1 [15.0]	53.6 [15.7]	50.8 [14.9]	44.8 [13.1]
Power		8.9	8.8	8.6	8.3	8.2	8.0	7.8	7.7	7.5	7.5	7.4	7.2	7.2	7.1	7.0
105 [40.6]		9.4	9.3	9.1	8.8	8.7	8.5	8.2	8.2	8.0	8.0	7.9	7.7	7.7	7.6	7.4
Total BTUH [KW]		88.5 [25.9]	86.6 [25.4]	82.6 [24.2]	81.1 [23.8]	79.4 [23.3]	75.7 [22.2]	70.4 [20.6]	69.0 [20.2]	65.8 [19.3]	63.5 [18.6]	62.2 [18.2]	59.3 [17.4]	55.3 [16.2]	54.1 [15.9]	51.6 [15.1]
Sens BTUH [KW]		58.8 [17.2]	55.8 [16.4]	49.1 [14.4]	65.9 [19.3]	62.6 [18.3]	55.1 [16.1]	63.9 [18.7]	60.6 [17.8]	53.4 [15.6]	59.1 [17.3]	56.1 [16.4]	49.4 [14.5]	51.5 [15.1]	48.9 [14.3]	43.1 [12.6]
Power		9.4	9.3	9.1	8.8	8.7	8.5	8.2	8.2	8.0	8.0	7.9	7.7	7.7	7.6	7.4
110 [43.3]		9.9	9.8	9.6	9.3	9.2	9.0	8.8	8.8	8.5	8.5	8.4	8.2	8.2	8.1	8.0
Total BTUH [KW]		84.7 [24.8]	83.0 [24.3]	79.1 [23.2]	77.3 [22.7]	75.7 [22.2]	72.2 [21.2]	66.7 [19.5]	65.3 [19.1]	62.2 [18.2]	59.7 [17.5]	58.5 [17.1]	55.8 [16.3]	51.5 [15.1]	50.4 [14.8]	48.1 [14.1]
Sens BTUH [KW]		56.5 [16.6]	53.6 [15.7]	47.2 [13.8]	63.6 [18.6]	60.3 [17.7]	53.1 [15.6]	61.6 [18.0]	58.4 [17.1]	51.4 [15.1]	56.8 [16.6]	53.9 [15.8]	47.4 [13.9]	49.2 [14.4]	46.7 [13.7]	41.1 [12.0]
Power		9.9	9.8	9.6	9.3	9.2	9.0	8.8	8.7	8.5	8.5	8.4	8.2	8.2	8.1	8.0
115 [46.1]		10.5	10.4	10.1	9.9	9.8	9.6	9.4	9.4	9.1	9.1	9.0	8.8	8.8	8.7	8.5
Total BTUH [KW]		80.6 [23.6]	79.0 [23.1]	75.3 [22.1]	73.3 [21.5]	71.7 [21.0]	68.4 [20.0]	62.6 [18.3]	61.3 [18.0]	58.4 [17.1]	55.7 [16.3]	54.5 [16.0]	52.0 [15.2]	47.4 [13.9]	46.5 [13.6]	44.3 [13.0]
Sens BTUH [KW]		53.9 [15.8]	51.1 [15.0]	45.0 [13.2]	61.0 [17.9]	57.8 [16.9]	50.9 [14.9]	58.9 [17.3]	55.9 [16.4]	49.2 [14.4]	54.1 [15.9]	51.4 [15.1]	45.2 [13.3]	46.6 [13.6]	44.2 [12.9]	38.9 [11.4]
Power		10.5	10.4	10.1	9.9	9.8	9.6	9.4	9.4	9.1	9.1	9.0	8.8	8.8	8.7	8.5
120 [48.9]		11.1	11.0	10.7	10.5	10.4	10.2	10.0	10.0	9.7	9.7	9.6	9.4	9.4	9.3	9.1
Total BTUH [KW]		76.2 [22.3]	74.7 [21.9]	71.2 [20.9]	68.9 [20.2]	67.5 [19.8]	64.3 [18.8]	58.2 [17.1]	57.0 [16.7]	54.4 [15.9]	51.3 [15.0]	50.2 [14.7]	47.9 [14.0]	43.1 [12.6]	42.2 [12.4]	40.2 [11.8]
Sens BTUH [KW]		50.9 [14.9]	48.3 [14.2]	42.5 [12.5]	58.0 [17.0]	55.0 [16.1]	48.5 [14.2]	56.0 [16.4]	53.1 [15.6]	46.8 [13.7]	51.2 [15.0]	48.6 [14.2]	42.8 [12.5]	43.1 [12.6]	41.4 [12.1]	36.4 [10.7]
Power		11.1	11.0	10.7	10.5	10.4	10.2	10.0	9.9	9.7	9.7	9.6	9.4	9.4	9.3	9.1
125 [51.7]		11.8	11.7	11.4	11.2	11.1	10.9	10.7	10.6	10.3	10.4	10.3	10.1	10.1	10.0	9.8
Total BTUH [KW]		71.5 [21.0]	70.1 [20.5]	66.8 [19.6]	64.2 [18.8]	62.8 [18.4]	59.9 [17.6]	53.5 [15.7]	52.4 [15.4]	50.0 [14.6]	46.6 [13.7]	45.6 [13.4]	43.5 [12.7]	38.4 [11.2]	37.6 [11.0]	35.8 [10.5]
Sens BTUH [KW]		47.7 [14.0]	45.2 [13.3]	39.8 [11.7]	54.8 [16.1]	52.0 [15.2]	45.8 [13.4]	52.8 [15.5]	50.1 [14.7]	44.1 [12.9]	46.6 [13.7]	45.5 [13.3]	40.1 [11.7]	38.4 [11.2]	37.6 [11.0]	33.7 [9.9]
Power		11.8	11.7	11.4	11.2	11.1	10.9	10.7	10.6	10.3	10.4	10.3	10.1	10.1	10.0	9.8

DR — Depression ratio  
 dbE — Entering air dry bulb  
 wBE — Entering air wet bulb

**NOTES:**  
 Total — Total capacity x 1000 BTUH  
 Sens — Sensible capacity x 1000 BTUH  
 Power — KW input

① When the entering air dry bulb is other than 80°F [27°C], adjust the sensible capacity from the table by adding [1.10 x CFM x (1 – DR) x (dbE – 80)].

[ ] Designates Metric Conversions

# COOLING PERFORMANCE DATA – RPCL2120+RHCLP2120

wBE		ENTERING INDOOR AIR @ 80°F [26.7°C] dbE ①											
		71°F [21.7°C]		67°F [19.4°C]		63°F [17.2°C]		61°F [16.1°C]		59°F [15.0°C]			
CFM [L/s]	DR ①	4500 [2124]	3400 [1605]	3000 [1416]	4500 [2124]	3400 [1605]	3000 [1416]	4500 [2124]	3400 [1605]	3000 [1416]	4500 [2124]	3400 [1605]	3000 [1416]
75 [23.9]	Total BTUH [KW] Sens BTUH [KW] Power	144.4 [42.3] 90.0 [26.4] 8.0	136.4 [40.0] 78.2 [22.9] 7.7	133.5 [39.1] 73.9 [21.7] 7.7	135.1 [39.6] 106.3 [31.2] 7.9	127.5 [37.4] 92.4 [27.1] 7.6	124.8 [36.6] 87.3 [25.6] 7.6	126.1 [37.0] 117.5 [34.4] 7.7	119.1 [34.9] 102.1 [29.9] 7.5	115.2 [33.8] 104.6 [30.6] 7.5	118.1 [34.6] 98.8 [29.0] 7.4	111.5 [32.7] 105.0 [30.8] 7.4	109.3 [31.9] 99.3 [29.1] 7.3
80 [26.7]	Total BTUH [KW] Sens BTUH [KW] Power	141.8 [41.5] 88.9 [26.1] 8.3	133.9 [39.2] 77.3 [22.6] 8.1	131.0 [38.4] 73.0 [21.4] 8.0	132.4 [38.8] 103.2 [30.8] 8.2	125.1 [36.6] 91.4 [26.8] 8.0	122.4 [35.9] 86.4 [25.3] 7.9	123.5 [36.2] 116.4 [34.1] 8.1	116.6 [34.2] 101.1 [29.6] 7.9	112.7 [33.0] 103.6 [30.4] 7.8	115.4 [33.8] 97.9 [28.7] 7.7	109.0 [31.9] 104.1 [30.5] 7.8	106.7 [31.3] 98.4 [28.8] 7.7
85 [29.4]	Total BTUH [KW] Sens BTUH [KW] Power	139.0 [40.7] 87.7 [25.7] 8.7	131.3 [38.5] 76.2 [22.3] 8.4	128.5 [37.6] 72.0 [21.1] 8.4	129.6 [38.0] 104.0 [30.5] 8.6	122.4 [35.9] 90.4 [26.5] 8.3	119.8 [35.1] 85.4 [25.0] 8.3	120.7 [35.4] 115.2 [33.8] 8.5	114.0 [33.4] 100.1 [29.3] 8.2	110.1 [32.3] 102.6 [30.1] 8.2	112.7 [33.0] 112.7 [33.0] 8.4	106.4 [31.2] 103.0 [30.2] 8.1	104.1 [30.5] 97.4 [28.5] 8.0
90 [32.2]	Total BTUH [KW] Sens BTUH [KW] Power	136.1 [39.9] 86.4 [25.3] 9.1	128.5 [37.7] 75.1 [22.0] 8.8	125.8 [36.9] 70.9 [20.8] 8.7	126.7 [37.1] 102.7 [30.1] 9.0	119.7 [35.1] 89.2 [26.1] 8.7	117.1 [34.3] 84.3 [24.7] 8.6	117.8 [34.5] 113.8 [33.4] 8.9	111.3 [32.6] 98.9 [29.0] 8.6	107.3 [31.5] 101.4 [29.7] 8.6	109.8 [32.2] 109.8 [32.2] 8.8	103.7 [30.8] 101.9 [29.9] 8.5	101.4 [29.7] 96.3 [28.2] 8.4
95 [35]	Total BTUH [KW] Sens BTUH [KW] Power	133.1 [39.0] 84.9 [24.9] 9.5	125.7 [36.8] 73.8 [21.6] 9.3	123.0 [36.0] 69.7 [20.4] 9.2	123.7 [36.2] 101.2 [29.7] 9.4	116.8 [34.2] 87.9 [25.8] 9.2	114.3 [33.5] 83.1 [24.4] 9.1	114.8 [33.6] 112.4 [32.9] 9.3	108.4 [31.8] 97.6 [28.6] 9.0	104.5 [30.6] 100.1 [29.3] 9.0	106.7 [31.3] 106.7 [31.3] 9.2	100.8 [29.5] 100.6 [29.5] 8.9	98.6 [28.9] 95.1 [27.9] 8.8
100 [37.8]	Total BTUH [KW] Sens BTUH [KW] Power	129.9 [38.1] 83.3 [24.4] 10.0	122.7 [35.9] 72.3 [21.2] 9.7	120.1 [35.2] 68.4 [20.0] 9.6	120.5 [35.3] 99.6 [29.2] 9.9	113.8 [33.4] 86.5 [25.3] 9.6	111.4 [32.6] 81.8 [24.0] 9.5	111.6 [32.7] 110.7 [32.4] 9.8	105.4 [30.9] 96.2 [28.2] 9.5	101.5 [29.7] 98.7 [28.9] 9.4	103.6 [30.3] 103.6 [30.3] 9.7	97.8 [28.7] 97.8 [28.7] 9.4	95.7 [28.0] 93.7 [27.5] 9.3
105 [40.6]	Total BTUH [KW] Sens BTUH [KW] Power	126.6 [37.1] 81.5 [23.9] 10.5	119.6 [35.0] 70.8 [20.7] 10.2	117.0 [34.3] 66.9 [19.6] 10.1	117.2 [34.4] 97.8 [28.7] 10.4	110.7 [32.4] 85.0 [24.9] 10.1	108.3 [31.7] 80.3 [23.5] 10.0	104.1 [30.5] 108.3 [31.7] 10.2	98.3 [28.8] 94.7 [27.7] 10.0	94.7 [27.7] 97.2 [28.5] 9.9	100.3 [29.4] 100.3 [29.4] 10.2	94.7 [27.7] 94.7 [27.7] 9.9	92.7 [27.2] 92.3 [27.0] 9.8
110 [43.3]	Total BTUH [KW] Sens BTUH [KW] Power	123.2 [36.1] 79.6 [23.3] 11.0	116.3 [34.1] 69.1 [20.3] 10.7	113.8 [33.4] 65.3 [19.1] 10.6	113.8 [33.3] 93.9 [28.1] 10.9	107.5 [31.5] 83.3 [24.4] 10.6	105.2 [30.8] 78.7 [23.1] 10.5	104.9 [30.7] 104.9 [30.7] 10.8	99.0 [29.0] 93.0 [27.3] 10.5	95.1 [27.9] 95.1 [27.9] 10.4	96.8 [28.4] 96.8 [28.4] 10.7	91.4 [26.8] 91.4 [26.8] 10.4	89.5 [26.2] 89.5 [26.2] 10.3
115 [46.1]	Total BTUH [KW] Sens BTUH [KW] Power	119.6 [35.0] 77.5 [22.7] 11.6	112.9 [33.1] 67.4 [19.7] 11.2	110.5 [32.4] 63.7 [18.7] 11.1	110.2 [32.3] 93.8 [27.5] 11.4	104.1 [30.5] 81.5 [23.9] 11.1	101.3 [29.7] 77.0 [22.6] 11.0	101.3 [29.7] 101.3 [29.7] 11.3	95.7 [28.0] 91.2 [26.7] 11.0	91.7 [26.9] 91.7 [26.9] 11.0	93.2 [27.3] 93.2 [27.3] 11.2	88.1 [25.8] 88.1 [25.8] 10.9	86.2 [25.3] 86.2 [25.3] 10.8
120 [48.9]	Total BTUH [KW] Sens BTUH [KW] Power	115.9 [34.0] 75.3 [22.1] 12.1	109.4 [32.1] 65.4 [19.2] 11.8	107.1 [31.4] 61.9 [18.1] 11.7	106.5 [31.2] 91.6 [26.9] 12.0	100.6 [29.5] 79.6 [23.3] 11.7	97.6 [28.8] 75.2 [22.0] 11.6	93.4 [27.4] 93.4 [27.4] 11.9	88.2 [25.9] 88.2 [25.9] 11.5	84.6 [24.8] 84.6 [24.8] 11.5	89.5 [26.2] 89.5 [26.2] 11.8	84.6 [24.8] 84.6 [24.8] 11.5	82.8 [24.3] 82.8 [24.3] 11.4
125 [51.7]	Total BTUH [KW] Sens BTUH [KW] Power	112.1 [32.8] 73.0 [21.4] 12.7	105.8 [31.0] 63.4 [18.6] 12.4	103.6 [30.3] 59.9 [17.6] 12.3	102.7 [30.1] 89.3 [26.2] 12.6	97.0 [28.4] 77.6 [22.7] 12.3	93.8 [27.5] 73.3 [21.5] 12.2	89.6 [26.3] 89.6 [26.3] 12.5	84.6 [24.8] 84.6 [24.8] 12.1	81.0 [23.7] 81.0 [23.7] 12.1	85.7 [25.1] 85.7 [25.1] 12.4	81.0 [23.7] 81.0 [23.7] 12.1	79.2 [23.2] 79.2 [23.2] 11.9

DR — Depression ratio  
 dbE — Entering air dry bulb  
 wBE — Entering air wet bulb

NOTES:  
 Total — Total capacity x 1000 BTUH  
 Sens — Sensible capacity x 1000 BTUH  
 Power — KW input

① When the entering air dry bulb is other than 80°F [27°C], adjust the sensible capacity from the table by adding [1.10 x CFM x (1 - DR) x (dbE - 80)].

[ ] Designates Metric Conversions

## HEATING PERFORMANCE DATA—RPCL2090+RHCLP2090

IDB		60°F [15.5°C]			70°F [21.1°C]			80°F [26.7°C]			
CFM [L/s]		3600 [1699]	3225 [1522]	2400 [1133]	3600 [1699]	3225 [1522]	2400 [1133]	3600 [1699]	3225 [1522]	2400 [1133]	
INDOOR DRY BULB TEMPERATURE	0 [-17.8]	Total BTUH [kW] Power	41.3 [12.1] 6.1	40.9 [12.0] 6.2	40.2 [11.8] 6.4	43.9 [12.9] 6.6	43.5 [12.8] 6.7	42.8 [12.5] 6.9	46.6 [13.6] 7.6	46.2 [13.5] 7.7	45.3 [13.3] 7.9
	5 [-15]	Total BTUH [kW] Power	45.7 [13.4] 6.2	45.4 [13.3] 6.2	44.5 [13.0] 6.4	48.4 [14.2] 6.7	48.0 [14.1] 6.8	47.1 [13.8] 7.0	51.0 [15.0] 7.6	50.6 [14.8] 7.8	49.7 [14.6] 8.0
	10 [-12.2]	Total BTUH [kW] Power	50.2 [14.7] 6.2	49.8 [14.6] 6.3	48.9 [14.3] 6.5	52.8 [15.5] 6.8	52.4 [15.4] 6.9	51.4 [15.1] 7.1	55.5 [16.3] 7.7	55.0 [16.1] 7.8	54.0 [15.8] 8.1
	15 [-9.4]	Total BTUH [kW] Power	54.7 [16.0] 6.3	54.2 [15.9] 6.4	53.2 [15.6] 6.6	57.3 [16.8] 6.8	56.8 [16.7] 6.9	55.8 [16.3] 7.2	59.9 [17.6] 7.8	59.5 [17.4] 7.9	58.4 [17.1] 8.2
	20 [-6.7]	Total BTUH [kW] Power	59.1 [17.3] 6.4	58.6 [17.2] 6.5	57.6 [16.9] 6.7	61.8 [18.1] 6.9	61.3 [18.0] 7.0	60.1 [17.6] 7.2	64.4 [18.9] 7.9	63.9 [18.7] 8.0	62.7 [18.4] 8.2
	25 [-3.9]	Total BTUH [kW] Power	63.6 [18.6] 6.4	63.1 [18.5] 6.5	61.9 [18.1] 6.7	66.2 [19.4] 7.0	65.7 [19.2] 7.1	64.5 [18.9] 7.3	68.9 [20.2] 7.9	68.3 [20.0] 8.0	67.1 [19.7] 8.3
	30 [-1.1]	Total BTUH [kW] Power	68.1 [19.9] 6.5	67.5 [19.8] 6.6	66.3 [19.4] 6.8	70.7 [20.7] 7.0	70.1 [20.5] 7.2	68.8 [20.2] 7.4	73.3 [21.5] 8.0	72.7 [21.3] 8.1	71.4 [20.9] 8.4
	35 [1.7]	Total BTUH [kW] Power	72.5 [21.3] 6.6	71.9 [21.1] 6.7	70.6 [20.7] 6.9	75.2 [22.0] 7.1	74.5 [21.8] 7.2	73.2 [21.4] 7.5	77.8 [22.8] 8.1	77.2 [22.6] 8.2	75.8 [22.2] 8.4
	40 [4.4]	Total BTUH [kW] Power	77.0 [22.6] 6.6	76.3 [22.4] 6.7	75.0 [22.0] 7.0	79.6 [23.3] 7.2	79.0 [23.1] 7.3	77.5 [22.7] 7.5	82.3 [24.1] 8.1	81.6 [23.9] 8.3	80.1 [23.5] 8.5
	45 [7.2]	Total BTUH [kW] Power	81.4 [23.9] 6.7	80.8 [23.7] 6.8	79.3 [23.2] 7.0	84.1 [24.6] 7.3	83.4 [24.4] 7.4	81.9 [24.0] 7.6	86.7 [25.4] 8.2	86.0 [25.2] 8.3	84.5 [24.7] 8.6
50 [10]	Total BTUH [kW] Power	85.9 [25.2] 6.8	85.2 [25.0] 6.9	83.6 [24.5] 7.1	88.6 [26.0] 7.3	87.8 [25.7] 7.4	86.2 [25.3] 7.7	91.2 [26.7] 8.3	90.5 [26.5] 8.4	88.8 [26.0] 8.7	

IDB—Indoor air dry bulb

[ ] Designates Metric Conversions



## HEATING PERFORMANCE DATA—RPCL2120CAZ+RHCLP2120CAR

IDB		60°F [15.5°C]			70°F [21.1°C]			80°F [26.7°C]			
CFM [L/s]		4500 [2124]	3400 [1605]	3000 [1416]	4500 [2124]	3400 [1605]	3000 [1416]	4500 [2124]	3400 [1605]	3000 [1416]	
INDOOR DRY BULB TEMPERATURE	0 [-17.8]	Total BTUH [kW] Power	35.2 [10.3] 2.5	34.4 [10.1] 2.6	34.1 [10.0] 2.6	33.0 [9.7] 3.5	32.3 [9.5] 3.6	32.0 [9.4] 3.7	30.9 [9.0] 3.9	30.2 [8.8] 4.1	29.9 [8.8] 4.1
	5 [-15]	Total BTUH [kW] Power	43.2 [12.7] 3.0	42.2 [12.4] 3.1	41.9 [12.3] 3.2	41.1 [12.0] 4.0	40.1 [11.8] 4.2	39.8 [11.7] 4.2	38.9 [11.4] 4.4	38.0 [11.1] 4.6	37.7 [11.1] 4.7
	10 [-12.2]	Total BTUH [kW] Power	51.3 [15.0] 3.5	50.1 [14.7] 3.6	49.7 [14.6] 3.7	49.1 [14.4] 4.5	48.0 [14.1] 4.7	47.6 [13.9] 4.8	47.0 [13.8] 4.9	45.9 [13.4] 5.1	45.5 [13.3] 5.2
	15 [-9.4]	Total BTUH [kW] Power	59.3 [17.4] 4.0	58.0 [17.0] 4.2	57.5 [16.8] 4.2	57.2 [16.7] 5.0	55.9 [16.4] 5.2	55.4 [16.2] 5.3	55.0 [16.1] 5.4	53.8 [15.8] 5.7	53.3 [15.6] 5.8
	20 [-6.7]	Total BTUH [kW] Power	67.3 [19.7] 4.5	65.8 [19.3] 4.7	65.3 [19.1] 4.8	65.2 [19.1] 5.5	63.7 [18.7] 5.8	63.2 [18.5] 5.8	63.0 [18.5] 6.0	61.6 [18.1] 6.2	61.1 [17.9] 6.3
	25 [-3.9]	Total BTUH [kW] Power	75.4 [22.1] 5.0	73.7 [21.6] 5.2	73.1 [21.4] 5.3	73.2 [21.5] 6.0	71.6 [21.0] 6.3	71.0 [20.8] 6.4	71.1 [20.8] 6.5	69.5 [20.4] 6.7	68.9 [20.2] 6.8
	30 [-1.1]	Total BTUH [kW] Power	83.4 [24.4] 5.6	81.5 [23.9] 5.8	80.9 [23.7] 5.9	81.3 [23.8] 6.6	79.4 [23.3] 6.8	78.8 [23.1] 6.9	79.1 [23.2] 7.0	77.3 [22.7] 7.3	76.7 [22.5] 7.4
	35 [1.7]	Total BTUH [kW] Power	91.5 [26.8] 6.1	89.4 [26.2] 6.3	88.7 [26.0] 6.4	89.3 [26.2] 7.1	87.3 [25.6] 7.4	86.6 [25.4] 7.5	87.2 [25.5] 7.5	85.2 [25.0] 7.8	84.5 [24.8] 7.9
	40 [4.4]	Total BTUH [kW] Power	99.5 [29.2] 6.6	97.3 [28.5] 6.9	96.5 [28.3] 7.0	97.4 [28.5] 7.6	95.2 [27.9] 7.9	94.4 [27.7] 8.0	95.2 [27.9] 8.0	93.1 [27.3] 8.3	92.3 [27.0] 8.5
	45 [7.2]	Total BTUH [kW] Power	107.6 [31.5] 7.1	105.1 [30.8] 7.4	104.3 [30.6] 7.5	105.4 [30.9] 8.1	103.0 [30.2] 8.4	102.2 [29.9] 8.6	103.3 [30.3] 8.5	100.9 [29.6] 8.9	100.1 [29.3] 9
50 [10]	Total BTUH [kW] Power	115.6 [33.9] 7.6	113.0 [33.1] 7.9	112.0 [32.8] 8.0	113.5 [33.2] 8.6	110.9 [32.5] 9.0	110.0 [32.2] 9.1	111.3 [32.6] 9.0	108.8 [31.9] 9.4	107.9 [31.6] 9.6	

IDB—Indoor air dry bulb

[ ] Designates Metric Conversions

## GENERAL INSTALLATION

The Remote Heat Pump unit must be installed outdoors. It should be located as near as possible to the indoor section to keep connecting refrigerant tubing lengths to a minimum. The unit must be installed to allow a free air flow to the outdoor coils.

If several units are installed adjacent to each other, care must be taken to avoid recirculation of air from one remote heat pump to another. In all installations, adequate space must be provided for installation and servicing.

The outdoor unit must not be connected to any duct work. Do not locate unit under a roof drip; if necessary, install gutters, etc., to prevent water run-off from hitting the unit. To prevent air recirculation, it is recommended that the unit not be installed under an overhang, but if necessary **allow a minimum of 60 inches [1524 mm] above the unit for air discharge.**

## SLAB INSTALLATION

Remote Heat Pump units should be set on a solid level foundation. When installed at ground level, the unit should be placed on a 6 inch [152.4 mm] cement slab. If the pad is formed at the installation site, do not pour the pad tight against the structure, otherwise vibration will be transmitted from the unit through the pad.

## ROOFTOP INSTALLATION

If rooftop installation is required, make certain that the building construction is adequate for the weight of the unit. (Refer to physical data chart.) Before placing the unit on the roof, make certain that the nylon rigging slings are of sufficient length to maintain equilibrium of the unit when lifting. Under no circumstances should the unit be lifted by only one corner for rooftop installation.

## RIGGING

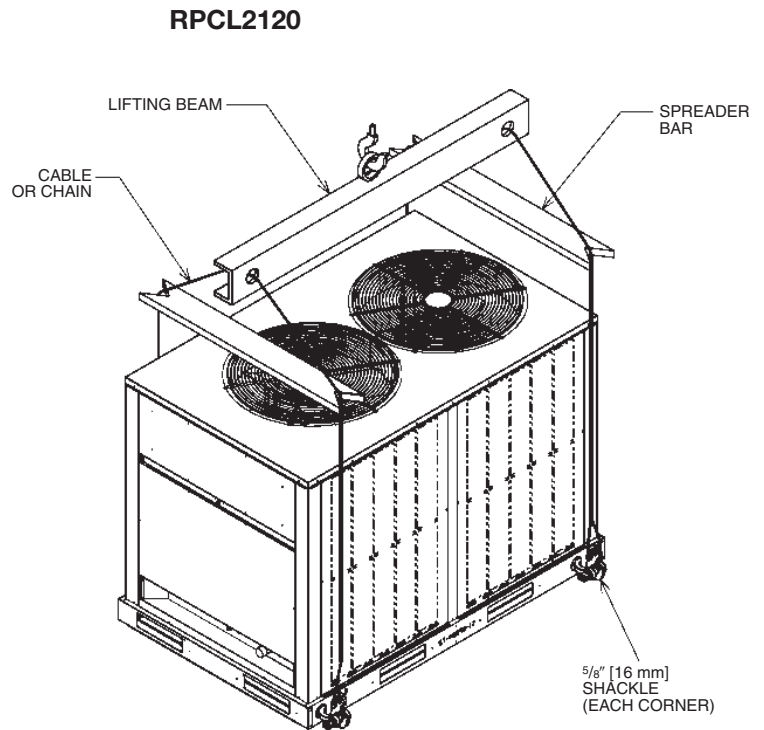
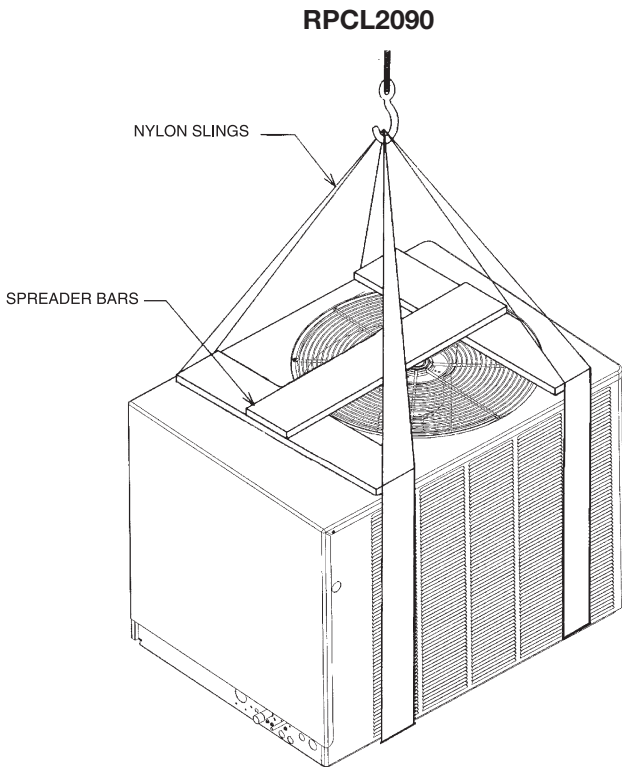

[ ] Designates Metric Conversions

# TYPICAL REFRIGERANT PIPING RECOMMENDATIONS

## General Notes:

1. Vertical risers not to exceed 60 feet [18.29 m].
2. Locate the remote heat pump unit and indoor air handler as close together as possible to minimize piping runs.
3. Remote heat pump units are shipped with a nitrogen holding charge. Evacuate remote heat pump unit before charging with refrigerant.
4. Runs between remote heat pump and indoor air handler are not to exceed 90' [27.43 m] linear length.

EQUIVALENT LENGTH (FT.) [m] OF STRAIGHT TYPE "L" TUBING FOR NON-FERROUS VALVES AND FITTINGS (BRAZED)				
TUBE SIZE INCHES [mm] O.D.	ANGLE VALVE	SHORT RADIUS ELL	LONG RADIUS ELL	TEE LINE FLOW
1/2 [12.7]	24 [7.32]	4.7 [1.43]	3.2 [0.98]	1.7 [0.52]
5/8 [15.88]	25 [7.62]	5.7 [1.74]	3.9 [1.19]	2.3 [0.70]
3/4 [19.05]	25 [7.62]	6.5 [1.98]	4.5 [1.37]	2.9 [0.88]
7/8 [22.23]	28 [8.53]	7.8 [2.38]	5.3 [1.62]	3.7 [1.13]
1 1/8 [28.58]	29 [8.84]	2.7 [0.82]	1.9 [0.58]	5.2 [1.59]
1 3/8 [34.93]	33 [10.06]	3.2 [0.98]	2.2 [0.67]	6.9 [2.10]

LINEAR LENGTH (FT.) [m]	RECOMMENDED VAPOR AND LIQUID LINE SIZES FOR VARIOUS LENGTHS OF RUN			
	LIQUID LINE O.D. SIZES (IN.) [mm]		VAPOR LINE O.D. SIZES (IN.) [mm]	
	090	120	090	120
0-40 [0-12.19]	1/2 [12.7]	5/8 [15.88]	1 1/8 [28.58]	1 3/8 [34.93]
41-90 [12.5-27.43]	1/2 [12.7]	5/8 [15.88]	1 3/8 [34.93]*	1 3/8 [34.93]*

\*NOTE: With the outdoor unit located below the indoor air handler, all vertical vapor lines must not exceed 1 1/8" [28.58 mm] O.D.

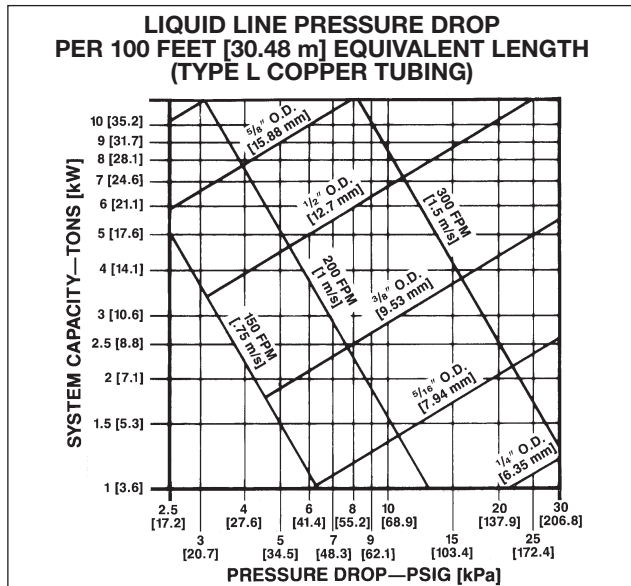

### NOTES:

- 1) The pressure drop due to vertical lift (.5 PSIG per foot of lift) [22.62 kPa per meter] **must** be added to the pressure drop derived from this curve.
- 2) Size liquid line for **no more** than 10°F [-12.2°C] loss (approximately 50 PSIG [344.8 kPa] total pressure drop).
- 3) **Do not oversize liquid line.** Oversized liquid lines add significantly to the amount of refrigerant required to charge the system.

### WARNING

Do not use oxygen to purge lines or pressure system for leak test. Oxygen reacts violently with oil, which can cause an explosion resulting in severe personal injury or death.

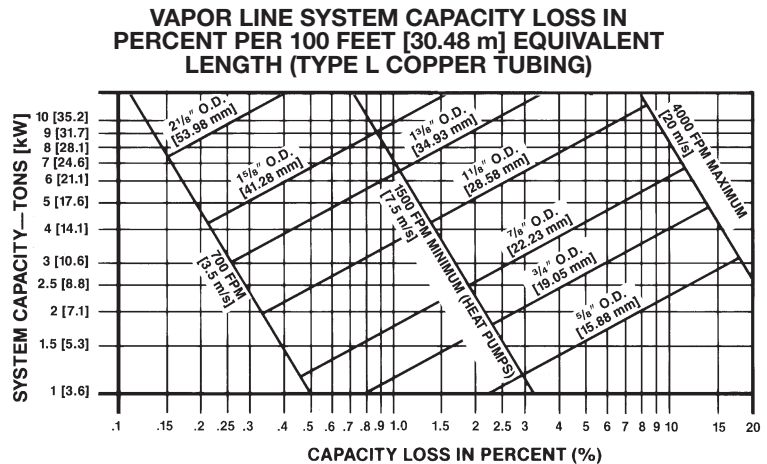

### NOTES:

- 1) The minimum velocity line (1500 FPM) [7.5 m/s] is recommended.
- 2) With the outdoor unit located below the indoor air handler, all vertical vapor lines must not exceed 1 1/8" [28.58 mm] O.D.
- 3) For suction pressure drop (PSIG) [6.9 kPa], multiply percent (%) loss by 1.18.
- 4) Size vapor lines for no more than a 5 PSIG [34.5 kPa] pressure drop (2.54% capacity loss) which corresponds to approximately 2°F [-16.7°C] loss.
- 5) All vertical vapor lines, 3 feet [.91 m] or more in length, must have a short radius oil trap at the bottom of the riser.
- 6) All vertical vapor lines, 30 feet [9.14 m] or more in length, must have short radius oil traps every 15 to 20 feet [4.57 to 6.10 m] of run.

## COIL ABOVE HEAT PUMP UNIT

## COIL BELOW HEAT PUMP UNIT

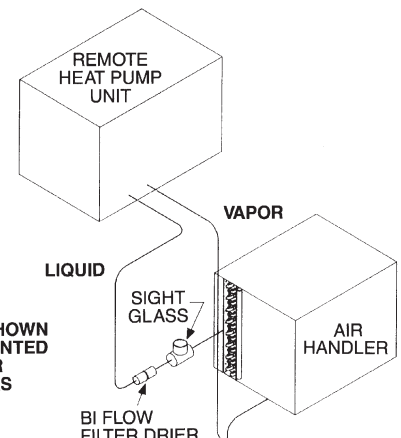

[ ] Designates Metric Conversions

## TYPICAL REFRIGERANT PIPING RECOMMENDATIONS (con't.)

REQUIRED OZS. R-410A CHARGE PER FT. [m] OF TUBING

TUBE SIZE O.D. (IN.) [mm]	LIQUID (OZ.) [g]	VAPOR (OZ.) [g]
1/2 [12.7]	1.06 [30.0]	.04 [1.13]
5/8 [15.88]	1.65 [46.7]	.07 [1.98]
3/4 [19.05]	2.46 [69.7]	.10 [2.83]
7/8 [22.23]	3.28 [92.9]	.13 [3.68]
1 1/8 [28.58]		.22 [6.23]
1 3/8 [34.93]		.34 [9.63]
1 5/8 [41.28]		.48 [13.60]
2 1/8 [53.98]		.84 [23.81]

Quantities based on 110°F liquid and 45°F vapor.

## GENERAL INSTALLATION 7.5 TON [26 kW] & 10 TON [35 kW]

The condensing unit should be installed outdoors. It should be located as near as possible to the evaporator section to keep connecting refrigerant tubing lengths to a minimum. The unit must be installed to allow a free air flow to the condenser coils.

If several units are installed adjacent to each other, care must be taken to avoid recirculation of air from one condenser to another. In all installations, adequate space must be provided for installation and servicing.

### CLEARANCES

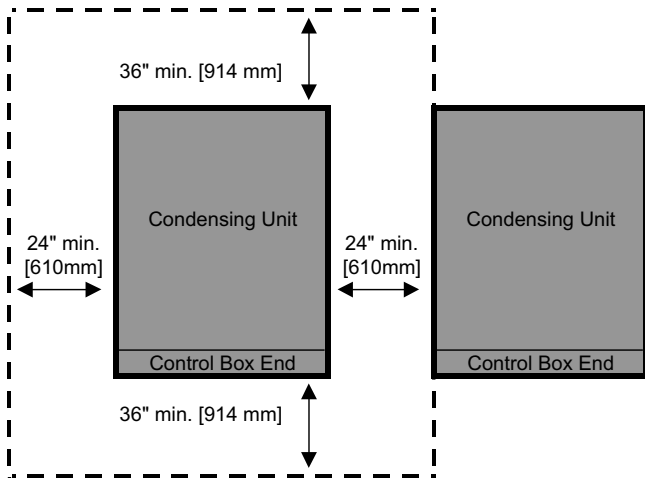

The unit must not be connected to any duct work. Do not locate unit under a roof drip; if necessary, install gutters, etc., to prevent water run-off from hitting the unit. To prevent air recirculation, it is recommended that the unit not be installed under an overhang, but if necessary allow a minimum of 60 inches [1524 mm] above the unit for air discharge.

[ ] Designates Metric Conversions

## ROOFTOP INSTALLATION

If rooftop installation is required, make certain that the building construction is adequate for the weight of the unit. (Refer to physical data chart.) Before placing the unit on the roof, make certain that the nylon rigging slings are of sufficient length to maintain equilibrium of the unit when lifting. Under no circumstances should the unit be lifted by only one corner for rooftop installation.

### RIGGING

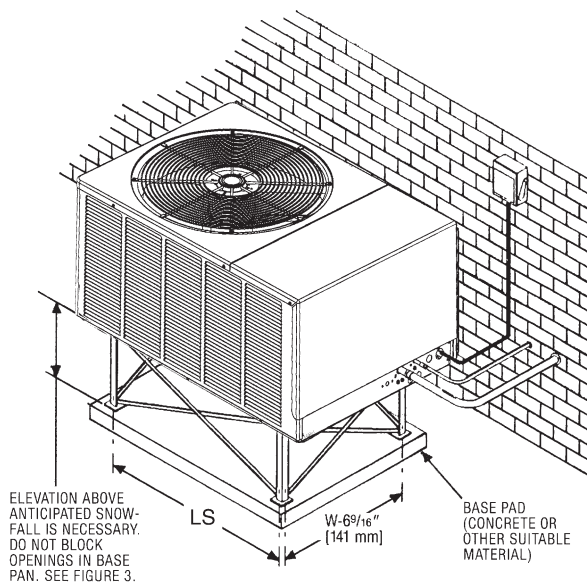
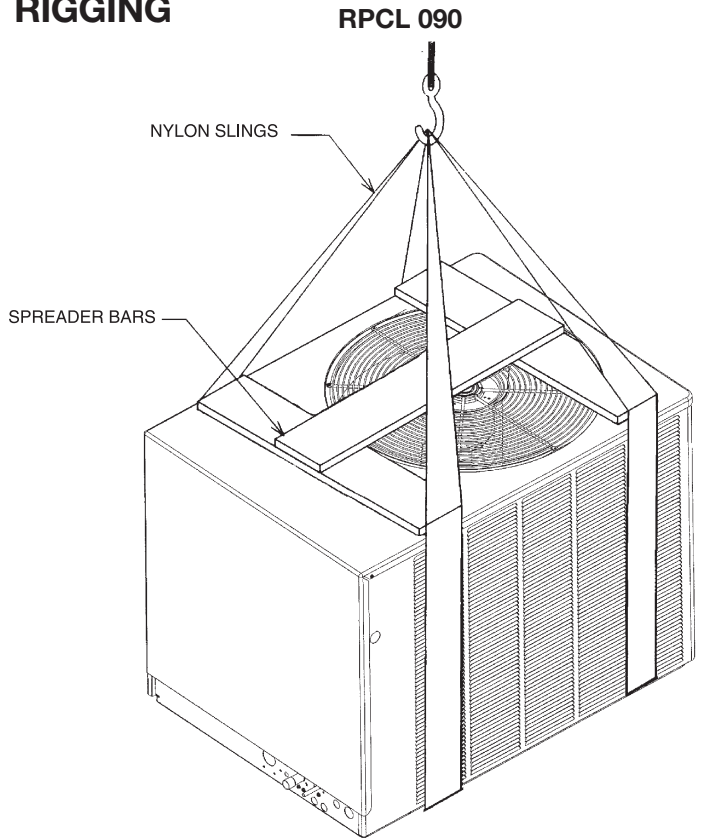

## SEQUENCE OF OPERATION

### COOLING MODE

When the 2-stage thermostat calls for the 1st stage of cooling, the outdoor fan motor is energized and the 1st stage of the compressor and indoor blower motor is energized. The system then provides cooling and dehumidification for the conditioned space. If the thermostat calls for the 2nd stage of cooling, the compressor shifts to the 2nd stage of capacity and the indoor blower motor speeds up to deliver the 2nd stage of airflow. The system will cycle between the 1st and 2nd stages as directed by the thermostat. When the call for cooling has ended or the thermostat is switched to the OFF position, the compressor outdoor fan motor and indoor blower motor are de-energized.

### HEATING MODE

When the heat pump thermostat is set to “heat” mode, the “B” terminal on the outdoor unit is energized which energizes the reversing valve and switches it to the heating position. When the 2-stage thermostat calls for the 1st stage of heating, the system then provides heating for the conditioned space. If the thermostat calls for the 2nd stage of heating, the compressor shifts to the 2nd stage of capacity and the indoor blower motor speeds up to deliver the 2nd stage of airflow. The system will cycle between the 1st and 2nd stages as directed by the thermostat. When the call for heating has ended, the compressor, outdoor fan motor, and indoor blower motor are de-energized. If the thermostat is switched to the OFF, the reversing valve solenoid is de-energized. If the system is operating in the heating mode when the thermostat is switched to the OFF position, the reversing valve will shift to the cooling position and will remain there until the thermostat is switched back to the HEAT mode and there is a call for heating.

### SUPPLEMENTAL ELECTRIC HEAT IN HEATING MODE

If the building load should exceed the heating capacity in extreme outdoor conditions, the thermostat will direct the air handler to energize supplemental electric heat as required to meet the building load as a 3rd stage of heat. The compressor and outdoor fan will continue to operate at maximum capacity while supplemental electric heat is energized. For 13kW heaters and higher, the electric heater elements are split into 2 stages controlled by energizing the W1 and W2 thermostat pigtailed on the air handler with 24VAC. Unless the W1 and W2 thermostat pigtailed are connected together at the air-handler, only the 1st stage of electric heat will be energized when supplemental heat is energized in the heat pump heating mode. If the 1st stage of electric heat is not sufficient for supplemental heat, the W1 and W2 thermostat pigtailed on the air handler should be connected together to provide maximum supplemental heat.

### DEMAND DEFROST

Defrosting of the outdoor coil in the heating mode is controlled by the defrost control located in the outdoor unit. RPCL heat pumps feature “demand defrost” that initiate a defrost cycle only when frosting is detected on the outdoor coil during heating operation. The defrost control monitors the Outdoor Ambient Temperature Thermistor and Outdoor Coil Temperature Thermistor to determine when a defrost cycle is required. The following sequence is followed for defrost cycles.

- **Defrost Initiation:** A defrost cycle is initiated when the following conditions are met.

1. The outdoor coil temperature is below 35°F [1.7°C].
2. The compressor has operated for at least 34 minutes with the outdoor coil temperature below 35°F [1.7°C].
3. The defrost control determines a defrost cycle is required based on the outdoor ambient and outdoor coil temperatures.

If the above conditions are met, the following action will be taken.

1. The reversing valve is de-energized which will cause it to shift to the cooling position and the outdoor fan motor is de-energized.
2. The compressor is de-energized for a 30 second noise abatement period.
3. The indoor airhandler or gas furnace is directed to supply supplemental heat to prevent cold air from being discharged from the supply registers during the defrost cycle.
4. The compressor is energized after the 30 second delay has been completed and defrosting of the coil begins.

- **Defrost Termination:** The defrost cycle will continue until the coil temperature has reached the termination temperature or 14 minutes have elapsed, whichever comes first. The factory default termination temperature is 70°F [21.1°C], although this temperature can be changed to 50°F [10.0°C], 60°F [15.6°C], or 80°F [26.7°C] by relocating a jumper on the defrost control board. When the coil temperature reaches the termination temperature or 14 minutes have elapsed, the following action is taken.

1. The reversing valve will be energized, switching it back to the heating position.
2. The compressor is de-energized for a 30 second noise abatement period.
3. Supplemental heat is de-energized.
4. The compressor and outdoor fan motor are energized after the 30 second delay has been completed.
5. The system returns to normal heating operation as directed by the thermostat.

**NOTE: Should the outdoor ambient temperature thermistor fail, the defrost control will initiate a defrost cycle every 34 minutes of operation when the coil temperature is below 35°F [1.7°C].**

See Section 7.1 (Demand Defrost Control) for additional information.

[ ] Designates Metric Conversions

## GUIDE SPECIFICATIONS

**GENERAL**—Units shall be assembled on heavy gauge steel full perimeter forkable baserails with lifting holes (10 ton only). Unit shall include a hermetic scroll compressor(s), plate fin condenser coil, fans and motors, controls and holding charge of nitrogen. Operating Range shall be between 115°F and 0°F in cooling as standard from factory. Units shall be UL 1995 listed and rated in accordance with AHRI Standard 340.

**CASING**—Unit shall be constructed of 18 gauge zinc coated heavy gauge, galvanized steel. Units shall have stamped louver panels offering 100% protection of condenser coil guards. Exterior surfaces shall be cleaned, phosphatized and finished with a weather-resistant baked enamel finish. Units surface shall be tested 1000 hours in salt spray test. Units shall have removable end panels which allow access to all major components and controls.

**REFRIGERATION SYSTEM—Single Compressor**—Units shall have a single refrigeration circuit. Each refrigeration circuit has an integral subcooling circuit. A refrigeration filter drier, expansion valve and check valves shall be provided as standard. The units shall have a liquid line and suction gas line service valve with gauge port. Units shall have one direct drive hermetic scroll compressor with centrifugal oil pump providing positive lubrication to moving parts. Motor shall be suction gas-cooled and shall have a voltage utilization range of plus or minus 10 percent of nameplate voltage. Crankcase heater, internal temperature and current-sensitive motor overloads shall be included for maximum protection. Scroll type compressor shall provide inherently low vibration and noise by having no suction and discharge valves. External high and low pressure cutout devices shall be provided.

**CONDENSER COIL**—Coils shall be internally finned or smooth bore 3/8" copper tubes mechanically bonded to configured aluminum plate fin as standard. Coil shall be factory pressure and leak tested to 450 psig air pressure.

**CONDENSER FAN AND MOTOR(S)**—Direct-drive, statically and dynamically balanced propeller fan(s) with aluminum blades and electro-coated steel hubs shall be used in draw-through vertical discharge position. Permanently lubricated totally enclosed construction type motors shall be provided and shall have built in current and thermal overload protection. Motor(s) shall have either ball or sleeve bearing type.

**CONTROLS**—Heat pump units shall be completely factory wired with necessary controls and contactor pressure lugs or terminal block for power wiring. Control wiring shall be 24-volt control circuit which includes fusing and control transformer. Units shall provide external location for mounting a fused disconnect device.

**DEFROST CONTROLS**—Unit shall be equipped with Demand Defrost Control to defrost outdoor coil.

**LOW AMBIENT OPERATION**—Standard units shall start and operate to 0° F when matched with Russell® By Rheem air handlers and coils. Standard head pressure control permits operation to 0° F.

**ANTI-SHORT-CYCLE TIMER**—Shall prevent rapid on-off compressor cycling in light load conditions by not allowing compressor to operate for 5-7 minutes upon shutdown. Shall consist of a solid state timing device, 24-volt, 60 cycle with either 5 or 7 minute fixed-off timing period.

**GENERAL TERMS OF LIMITED WARRANTY\***

Rheem® will furnish a replacement for any part of this product which fails in normal use and service within the applicable periods stated, in accordance with the terms of the limited warranty.

Compressor .....Five (5) Years  
Any Other Part .....One (1) Year

**\*For Complete Details of the Limited Warranty, Including Applicable Terms and Conditions, See Your Local Installer or Contact the Manufacturer for a Copy.**



***Russell® By Rheem***

5600 Old Greenwood Road, Fort Smith, AR 72908

Before proceeding with installation, refer to installation instructions packaged with each model, as well as complying with all Federal, State, Provincial, and Local codes, regulations, and practices.