



PROJECT NAME \_\_\_\_\_

LOCATION \_\_\_\_\_

ARCHITECT \_\_\_\_\_

ENGINEER \_\_\_\_\_

CONTRACTOR \_\_\_\_\_

SUBMITTED BY \_\_\_\_\_ DATE \_\_\_\_\_

**UNIT SUMMARY**

Quantity						
Unit Designation						
Model No.						
Total Cooling						
Sensible Cooling						
Air Ent. Evaporator						
Air Lvg. Evaporator						
Heating Input						
Heating Output						
CFM/ESP						
EER/SEER						
Electrical						
Minimum Ampacity						
Min.-Max. Breaker						
Net Unit Weight						
Accessory						
Catalog Form Number						

**ACCESSORIES:**

**NOTES:**

# Vantix® Line SH2CY Air Handlers

## Two-Stage Airflow

### Constant Torque Motor

### Efficiencies: 13.4 to 16.0 SEER2

### Refrigerant Type: R-454B

JOB NAME \_\_\_\_\_ LOCATION \_\_\_\_\_

CONTRACTOR \_\_\_\_\_ ORDER NO. \_\_\_\_\_

ENGINEER \_\_\_\_\_ UNIT MODEL NO. \_\_\_\_\_

SUBMITTED FOR  APPROVAL  RECORD COIL MODEL NO. \_\_\_\_\_

DATE \_\_\_\_\_ AIR HANDLER MODEL NO. \_\_\_\_\_

#### UNIT DATA

##### COOLING PERFORMANCE

EFFICIENCY ..... SEER

TOTAL CAPACITY\* ..... MBH [kW]

SENSIBLE CAPACITY\* ..... MBH [kW]

OUTDOOR DESIGN TEMP..... °F [°C] DB

TEMP. OF AIR ENTERING  
EVAPORATOR COIL ..... °F [°C] DB

..... °F [°C] WB

POWER INPUT REQUIREMENT ..... kW  
(\*uses blower motor heat)

##### HEATING PERFORMANCE

EFFICIENCY ..... HSPF

TOTAL CAPACITY\* ..... MBH [kW]

OUTDOOR DESIGN TEMP..... °F [°C] DB

TEMP. OF AIR ENTERING  
EVAPORATOR COIL ..... °F [°C] DB

##### SUPPLY AIR BLOWER PERFORMANCE

TOTAL AIR SUPPLY..... CFM [L/s]

TOTAL RESISTANCE EXTERNAL  
TO UNIT ..... IWG

BLOWER SPEED..... RPM

POWER OUTPUT REQUIREMENT ..... BHP

MOTOR RATING ..... HP [W]

POWER INPUT REQUIREMENT ..... kW

##### ELECTRICAL DATA

POWER SUPPLY ..... Hz

TOTAL UNIT AMPACITY..... AMPS

MINIMUM WIRE SIZE ..... AWG

MAXIMUM OVERCURRENT DEVICE  
FUSES/HACR BREAKER ..... AMPS

##### CLEARANCES

ACCESS SIDE 24" [609.6 mm]

AIR INLETS 12" [304.8 mm]

ABOVE UNIT 60" [1524 mm]

#### FEATURES

- **Quiet Operation<sup>1</sup>:** Provided by a cabinet construction with 1.0 inch of foil faced insulation for quieter sound characteristics
- **Aluminum Indoor Coil Design:** Constructed of aluminum fins bonded to internally grooved aluminum tubing and are more corrosion resistant
- **Versatile 4-Way Convertible Compact Design:** Allow for upflow, downflow, horizontal left and horizontal right applications even in the smallest of spaces
- **Rugged Steel, Compact Cabinet Construction:** Designed for added strength and versatility
- **Field Installed Auxiliary Heater Kits:** Provide exact heat for indoor comfort and include circuit breakers which meet UL and cUL requirements for service disconnect
- **Less than 2% Cabinet Air Leakage at 1-inch H<sub>2</sub>O:** When tested in accordance with ASHRAE Standard 193
- **Mobile/Manufactured Home Capability:** Designed to be suitable for installation in mobile/manufactured homes
- **Designing for Sustainability with Low GWP:** For 2025, the Environmental Protection Agency (EPA) has set a global warming potential (GWP) limit of 700 for refrigerant used in heating and cooling systems. This new requirement will result in a 78%<sup>2</sup> lower GWP than previous-generation refrigerants — with only minimal changes to system installation. For us, this is another step toward our continued sustainability goal of reducing greenhouse gas emissions, while still delivering an exceptional level of energy efficient, dependable comfort
- **Refrigerant Detection System<sup>TM3</sup>:** An integrated one-box, patented design featuring the A2L sensor and mitigation board, offering easier commissioning with a single component and simplified wiring configuration, compatibility with any 24V thermostat application and system protection by automatically pausing outdoor unit operation — if excess refrigerant is detected



9001:2015



<sup>1</sup>Based on manufacturer's air handler offering, and the product's airflow stages, motor type and cabinet insulation. Sound levels are also dependent on air handler location and installation <sup>2</sup>When comparing the GWP of R-454B to R-410A refrigerant <sup>3</sup>Factory or field installed in the furnace coil or air handler and is applicable to the complete heating and cooling system featuring Low GWP Refrigerant (A2L)

# SH2CY

ELECTRICAL CONNECTIONS  
MAY EXIT TOP OR EITHER SIDE

HIGH VOLTAGE CONNECTION 7/8" [22.2 mm],  
1 9/32" [27.8 mm], 1 3/32" [50 mm] DIA. KNOCKOUTS.

LOW VOLTAGE CONNECTION  
3/8" [15.9 mm] AND 1/2" [22.2 mm] KNOCKOUT

AUXILIARY DRAIN CONNECTION  
3/4" [19.1 mm] FEMALE PIPE THREAD (NPT)  
HORIZONTAL APPLICATION ONLY

PRIMARY DRAIN CONNECTION  
3/4" [19.1 mm] FEMALE PIPE THREAD (NPT)

AUXILIARY DRAIN CONNECTION  
3/4" [19.1 mm] FEMALE PIPE THREAD (NPT)  
UPFLOW/DOWNFLOW APPLICATION ONLY

LIQUID LINE CONNECTION  
COPPER (SWEAT)

VAPOR LINE CONNECTION  
COPPER (SWEAT)

SUPPLY AIR ↑

NOTE: 24" CLEARANCE REQUIRED IN FRONT OF  
UNIT FOR FILTER AND COIL MAINTENANCE.

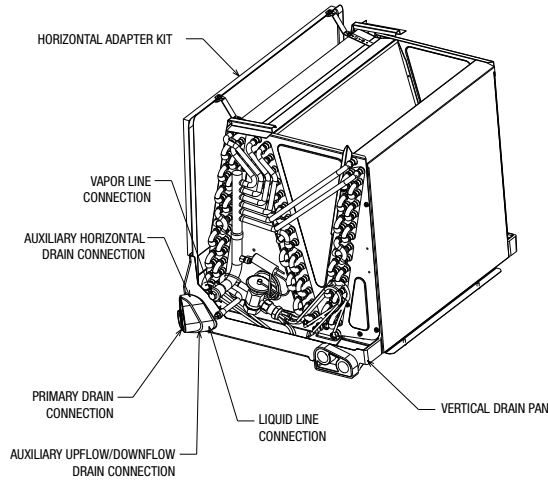
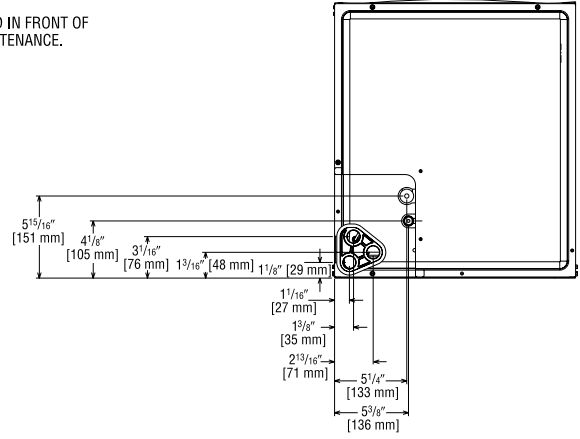
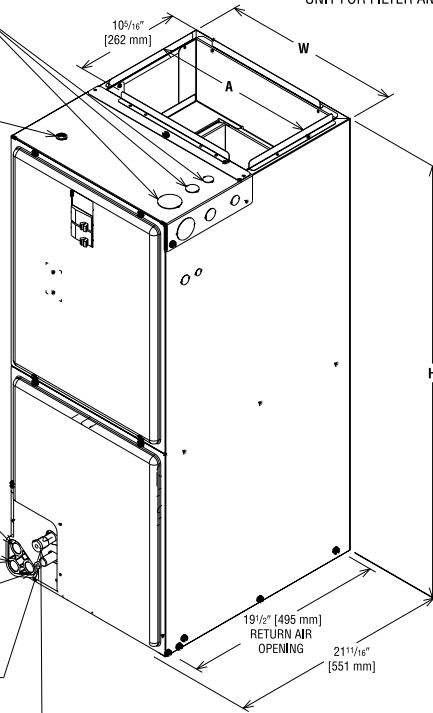

## Return Air Opening Dimensions

Model Cabinet Size	Return Air Opening Width (Inches)	Return Air Opening Depth/Length (Inches)
17	15 7/8	19 3/4
21	19 3/8	19 3/4
24	22 7/8	19 3/4

UPFLOW UNIT SHOWN: UNIT MAY BE INSTALLED UPFLOW,  
DOWNFLOW, HORIZONTAL RIGHT OR LEFT AIR SUPPLY.  
[ ] Designates Metric Conversions  
( ) Designates Unit with Double Coil Cabinet

## Unit Dimensions

Model Size SH2CY	Refrigerant Connections Sweat (In.) [mm] ID		Unit Width "W" In. [mm]	Unit Height "H" In. [mm]	Supply Duct "A" In. [mm]	Air Flow CFM (Nom.) [L/s]		Unit Weight/Shipping Weight (Lbs.) [kg]
	Liquid	Vapor				Lo	Hi	
2417ST	3/8 [9.53]	3/4 [19.05]	17-1/2 [445]	42-1/2 [1080]	16 [406]	600 [283]	800 [378]	92/106 [42/48]
3617ST	3/8 [9.53]	3/4 [19.05]	17-1/2 [445]	42-1/2 [1080]	16 [406]	1000 [472]	1200 [566]	96/110 [44/50]
3621ST	3/8 [9.53]	3/4 [19.05]	21 [533]	42-1/2 [1080]	19-1/2 [495]	525 [248]	700 [330]	111/126 [50/57]
3621MT**N	3/8 [9.53]	7/8 [22.23]	21 [533]	50-1/2 [1282]	19-1/2 [495]	1000 [472]	1200 [566]	126/142 [57/64]
3621MT**A	3/8 [9.53]	7/8 [22.23]	21 [533]	57 [1448]	19-1/2 [495]	1000 [472]	1200 [566]	137/149 [62/68]
4821ST**N	3/8 [9.53]	7/8 [22.23]	21 [533]	50-1/2 [1282]	19-1/2 [495]	1400 [661]	1600 [755]	128/144 [56/65]
4821ST**A	3/8 [9.53]	7/8 [22.23]	21 [533]	57 [1448]	19-1/2 [495]	1400 [661]	1600 [755]	139/151 [63/68]
4824ST**N	3/8 [9.53]	7/8 [22.23]	24-1/2 [622]	55-1/2 [1410]	23 [584]	1050 [495]	1400 [660]	128/146 [58/66]
4824MT**N	3/8 [9.53]	7/8 [22.23]	24-1/2 [622]	55-1/2 [1410]	23 [584]	1200 [566]	1600 [755]	161/178 [73/81]
6021ST**A	3/8 [9.53]	7/8 [22.23]	21 [533]	57 [1448]	19-1/2 [495]	1600 [755]	1725 [814]	139/151 [63/68]
6024ST	3/8 [9.53]	7/8 [22.23]	24-1/2 [622]	55-1/2 [1410]	23 [584]	1200 [566]	1600 [755]	161/178 [73/81]

[ ] Designates Metric Conversions

Before proceeding with installation, refer to installation instructions packaged with each model, as well as complying with all Federal, State, Provincial, and Local codes, regulations, and practices.

© 2025 Rheem Manufacturing Company. Trademarks are property of their respective owners.

In keeping with its policy of continuous progress and product improvement, manufacturer reserves the right to make changes without notice.

5600 Old Greenwood Road • Fort Smith, Arkansas 72908