

RELY ON



## Commercial Renaissance® Line Achiever Plus® Series Packaged Heat Pumps



### RHPCYC Series

Cooling Efficiencies up to: 16.1 SEER2 / 11.0 EER2  
Nominal Sizes: 3, 4 & 5 Tons [10.6, 14.0 & 17.6 kW]  
Cooling Capacities: 34.2k Btu/h to 57.0k Btu/h  
Refrigerant Type: R-454B  
ASHRAE 90.1 2022 Compliant Models



9001:2015



LISTED



Unitary Small HP  
AHRI Standard 210/240

Certification applies only when the complete system  
is listed with AHRI

## TABLE OF CONTENTS

Unit Features & Benefits .....	3-9
Model Number Identification .....	10
Options .....	11
Selection Procedure .....	12
General Data.....	13-15
General Data Notes .....	16
Weighted Sound Power .....	16
Gross Systems Performance Data .....	17-21
Airflow Performance Data .....	22-27
Electrical Data.....	28-29
Heater Kit Characteristics .....	30-32
Safety Data .....	33
Dimensional Data .....	34-36
Field-Installed Accessories.....	37-55
Guide Specifications .....	56-61
Limited Warranty .....	62



## RHPCYC STANDARD FEATURES INCLUDE:

### Manufacturing & Quality Features

- Factory charged with R-454 refrigerant
- Wired and run tested at the factory
- Powder Paint Finish meets ASTM® B117 test requirements. G90 galvanized steel coated on each side
- Foil faced insulation encapsulated throughout entire unit minimizes airborne fibers in the air stream

### Performance Features

- Advanced unitary controller for easier integration and setup with easy to read and use 3" LCD screen
- Standard compatibility with Universal 24V control, BACnet® MS/TP- and BACnet IP-ready
- Cooling operation up to 125°F ambient
- Scroll compressors with internal line break overload and high-pressure protection
- Two stages of cooling and heat pump operation
- Full MicroChannel coils with patented defrost design
- High pressure and low pressure/loss of charge protection

### Convenience & Serviceability Features

- Forkable base rails for easy handling and lifting
- Color-coded and labeled wiring
- Laser-etched panel doors to identify each compartment from the exterior
- External, lockable gauge ports
- Field convertible airflow—vertical downflow or horizontal sideflow
- Solid-core liquid line filter drier
- Filter access features hinged access with heavy-duty gasketing and 1/4 turn latches
- Slide-out indoor fan assembly for added service convenience
- Slide-out, internally sloped condensate drain pan with overflow switch, conforms to ASHRAE 62 standards
- Qwik-change flex-fit filter rack for easy filter size changes
- Factory-installed refrigerant leak detection system

## FACTORY-INSTALLED OPTIONS:

- Louvered panels
- Hinged access doors
- Low ambient/freeze stat
- Non-powered convenience outlet

- Vertical Economizer (Title 24 and ASHRAE 90.1 2022 compliant)
- Return and supply smoke detector
- ElectroFin® E-Coat for MicroChannel Condenser Coil Coating

## FIELD-INSTALLED ACCESSORIES

Accessory	Model Number	Factory Installation Available?
Non-DDC Economizer with Single Enthalpy (Downflow) <i>MicroMetl Economizer with Siemens® Controls</i>	RXRD-11MCDAM3	Yes
Non-DDC Economizer with Single Enthalpy (Downflow) <i>RRS Economizer with Siemens Controls</i>	RXRD-51MCDAM3	No
Non-DDC Economizer with Single Enthalpy (Horizontal) <i>MicroMetl Economizer with Siemens Controls</i>	RXRD-11MCHAM3	No
Non-DDC Economizer with Single Enthalpy (Horizontal) <i>RRS Economizer with Siemens Controls</i>	RXRD-51MCHAM3	No
Power Exhaust (230V) Horizontal <i>MicroMetl</i>	RXR-CCF03C	No
Power Exhaust (230V) Horizontal <i>RRS</i>	RXR-RCF03C	No
Power Exhaust (230V) Vertical <i>MicroMetl</i>	RXR-CCF02C	No
Power Exhaust (230V) Vertical <i>RRS</i>	RXR-RCF02C	No
Power Exhaust (460V) Horizontal <i>MicroMetl</i>	RXR-CCF03D	No
Power Exhaust (460V) Horizontal <i>RRS</i>	RXR-RCF03D	No
Power Exhaust (460V) Vertical <i>MicroMetl</i>	RXR-CCF02D	No
Power Exhaust (460V) Vertical <i>RRS</i>	RXR-RCF02D	No
Concentric Adapter 3 & 4 Ton Drop	RXMC-DC01	No
Concentric Adapter 5 Ton Drop	RXMC-DC02	No
Concentric Diffuser 3 & 4 Ton Drop	RXRN-AED1800	No
Concentric Diffuser 5 Ton Drop	RXRN-AED2000	No
Concentric Diffuser 3 & 4 Ton Flush	RXRN-AEF1800	No
Concentric Diffuser 5 Ton Flush	RXRN-AEF2000	No
Convenience Outlet, Non-Powered	RXR-BN01	Yes
Electric Heater Kit   208/230V, 1ph, 10kW	RXJJ-DC10JT	Yes

Accessory	Model Number	Factory Installation Available?
Electric Heater Kit   208/230V, 1ph, 15kW	RXJJ-DC15JT	Yes
Electric Heater Kit   208/230V, 1ph, 20kW	RXJJ-DC20JT	Yes
Electric Heater Kit   208/230V, 3ph, 10kW	RXJJ-DC10CP	Yes
Electric Heater Kit   208/230V, 3ph, 15kW	RXJJ-DC15CP	Yes
Electric Heater Kit   208/230V, 3ph, 20kW	RXJJ-DC20CP	Yes
Electric Heater Kit   460V, 3ph, 10kW	RXJJ-DC10DNV	Yes
Electric Heater Kit   460V, 3ph, 15kW	RXJJ-DC15DNV	Yes
Electric Heater Kit   460V, 3ph, 20kW	RXJJ-DC20DNV	Yes
Fresh Air Damper, Manual	RXRF-ACA1	No
Fresh Air Damper, Motorized	RXRF-ACB1	No
MERV 8 Filter	RXMF-M08A21616	No
MERV 13 Filter	RXMF-M13A21616	No
Outdoor Coil Louver Kit	RXR-ADD04C	Yes
Roofcurb Adapter	RXR-DCCAE	No
Roofcurb, 14"	RXKG-DCC14	No
Roofcurb, 24"	RXKG-DCC24	No
Single Point Wiring Kit (Single Phase)	RXJX-AJ0601	No
Single Point Wiring Kit (Three Phase)	RXJX-AZ0601	No
Unfused Service Disconnect	RXR-BP01	Yes
UV-C Light Kit 208/230V	RXR-UV22C	No
UV-C Light Kit Transformer 460V	RXR-UVCTC	No
Dual Enthalpy, Temperature and Humidity Sensor (for Siemens)	PD555460	No
Low-Ambient Control Kit	RXRZ-A07	Yes
Sensor, Carbon Dioxide (Wall Mount)	RXR-AR02	No
Smoke Detector, Return (Field kit)	RXR-BS01	No
Smoke Detector, Return/Supply (Field kit)	RXR-BS02	No

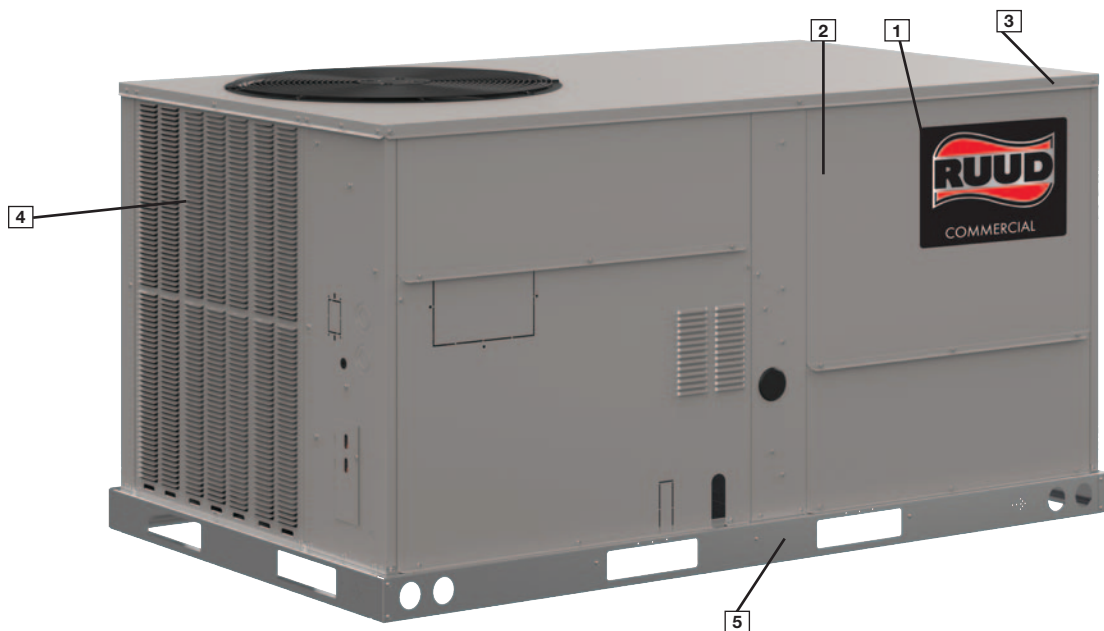

### Cabinet and Foundation

Outwardly, the large *Ruud® Commercial* label (1) identifies the brand to the customer. The sheet-metal cabinet (2) uses 18-gauge material for structural components with an under coat of G90. To ensure the leak-proof integrity of these units, the design utilizes a one-piece top with a 1/8" drip lip (3) as well as gasket-protected panels and screws. The Ruud hail guard (optional) (4) sets the standard for coil protection in the industry. Electro deposition, baked-on enamel that is tested to withstand a rigorous 1000-hour salt spray test, per ASTM B117.

Anything built to last must start with the right foundation. Following that model, the foundation is comprised of 14-gauge, commercial-grade, full perimeter base rails (5) that integrate fork slots and rigging holes to save set-up time on the job site.

### Easy Installation

The Renaissance line is designed to simplify the installation and replacement process with a footprint that matches existing airflow inlets, outlets and electrical connections to commonly used curb configurations in the market today.

### Base Pan

The base pan is stamped to form a 7/8" flange around the supply and return cover, which eliminates the worry of water entering the conditioned space (6). All insulation is secured with both adhesive and mechanical fasteners, and all edges are hidden.



### Drain Pan

The Qwik-Clean Drain Pan (7) is made from a composite material that resists the growth of harmful bacteria. With both side and center drain options, the drain pan slides out completely for easy cleaning. It also features a standard overflow switch.



### Test Standards

During development, each unit was tested to U.L. 60335-2-40, AHRI 210/240, as well as other Ruud-required reliability tests. Ruud adheres to stringent ISO 9001 quality procedures, and each unit bears the U.L. and AHRI certification labels located on the unit nameplate. Contractors can be assured that when a Ruud packaged unit arrives at the job, it is ready to go with a factory charge and quality checks.

### Easy Access

All major compartments are easily accessible from the front of the unit: the electrical compartment, blower compartment, heating section, and outdoor section. Each compartment has mechanical fasteners. Panels are permanently embossed with the compartment name (e.g. control/filter access, blower access, and electric heat access). The filter compartment is accessed through a large, mechanically fastened panel. Information is readily available on the outside of the panel, with a nameplate that contains the model and serial numbers, electrical data, and other important unit information. Hinged access is available as an option for the electrical, blower, and filter compartments.

## Charging Charts, Wiring Diagrams & Labels

The unit charging chart is located on the outside of the compressor access panel. Electrical wiring diagrams are found on the control box cover, which allows contractors to move them to more readable locations. The model and serial numbers are located on the right of the control box. Having this information on the inside means easier model identification for the life of the product. The production line quality test assurance label is also placed in this location ([8]).

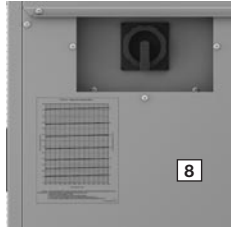

## Filter Rack

Located within the filter compartment, the Qwik-Change Flex-Fit Rack ([9]) allows easy changeover between 2" and 4" standard size and readily available filters.



## Blower Assembly

Removing three screws provides full access to the blower compartment. Inside, the Qwik-Slide Blower Assembly ([10]) is incredibly easy to access and remove. This makes servicing internal components such as blower motor, TXV, and MicroChannel coil much easier. The entire assembly slides out by removing the 3/8" screws from the blower retention bracket.

Where the demands for the job require high static, Ruud offers drives ([11]) that deliver nominal airflow up to 1.5" of static. By referring to the airflow performance tables listed in the installation instructions, proper static pressure and CFM requirements can be dialed in. The scroll housing ([12]) and blower scroll provide quiet and efficient airflow.

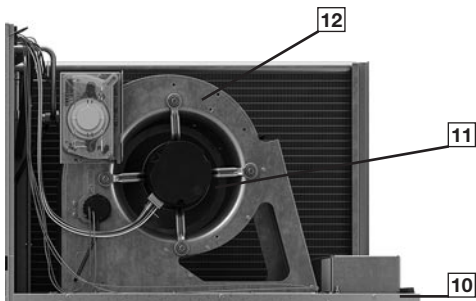

## High and Low Pressure Switches & Freeze Sensor

High pressure ([13]) and low pressure ([14]) switches are standard. They are located in the outdoor section along with the low-ambient control ([15]). The standard freeze sensor ([16]), is clipped onto the suction line in the blower compartment. The low ambient control allows the compressor to operate down to 30°F degrees ambient temperature by cycling the outdoor fans on high pressure. The high-pressure switch shuts off the compressors if pressures exceeding 610 PSIG are detected. The low-pressure switch shuts off the compressors if low pressure is detected due to loss of charge. The advanced unitary controller reduces nuisance calls by only shutting off compressors after the fourth detection. The freeze sensor protects the compressor if the evaporator coil gets too cold (below freezing) due to low airflow.

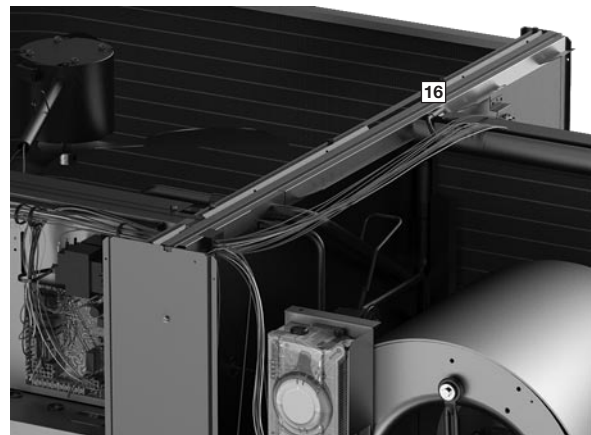
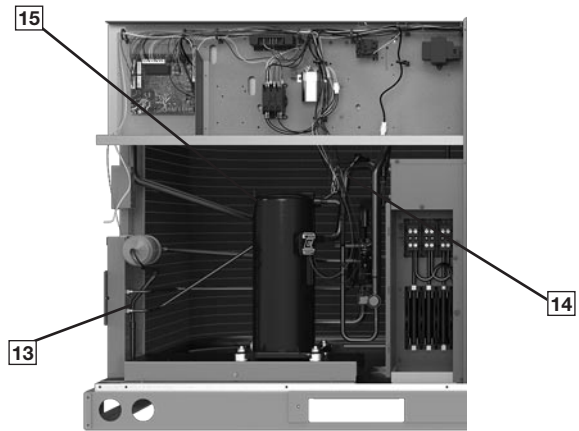

## MicroChannel Evaporator & TXV

The MicroChannel Evaporator ([17]) is accessible through the blower compartment, and through the filter rack, to simplify cleaning. The evaporator uses MicroChannel technology for maximum heat transfer, light weight, fewer manually brazed connections and reduced refrigerant charge. The TXV metering device maintains superheat over a wide range of varying temperatures optimizing unit performance for all conditions.

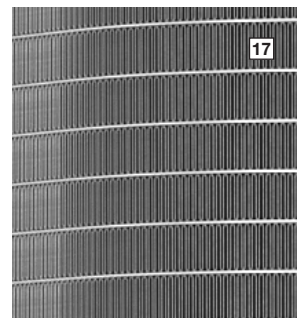

## Control Box

Inside the control box (18), each electrical component is clearly labeled; that label matches the component to the wire diagram for ease of trouble shooting. All wiring is numbered on each end of the termination and is color-coded to match the wiring diagram (19). The Advanced Unitary Controller (20) incorporates a 22 character LCD display to easily navigate through the Human Machine Interface (HMI) and with easy-to-understand fault codes. The control transformer has a low voltage circuit breaker that trips if an electrical short occurs.

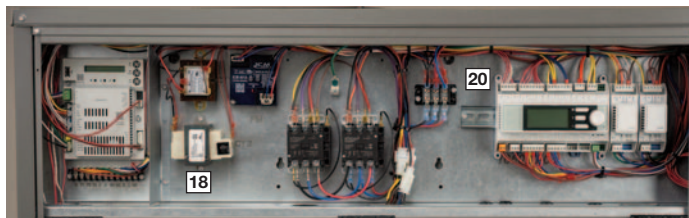

## Advanced Unitary Controller

The standard Advanced Unitary Controller system consisting of a rooftop unit controller, temperature sensors, pressure controls, allows real-time monitoring and communication between rooftop units. It is factory mounted and wired into the control panel. The controller is a solid-state, microprocessor-based control board that provides flexible control and extensive diagnostics for all unit functions. The unit controller is a solid-state, microprocessor-based control board that provides flexible control and extensive diagnostics for all unit functions. Using proportional/integral control algorithms, it also performs specific unit functions that govern unit operation in response to zone conditions, system temperatures, ambient conditions, and electrical inputs. The controller features a 22 character by 5 line LCD display (21), three keys, and a push and scroll navigation wheel (22) for local configuration and direct diagnosis of the system. Features include a clogged filter switch (CFS), fan proving switch (FPS), return air temperature sensor (RAT), discharge air temperature sensor (DAT), and outdoor air temperature sensor (OAT), and freeze sensors (FS).

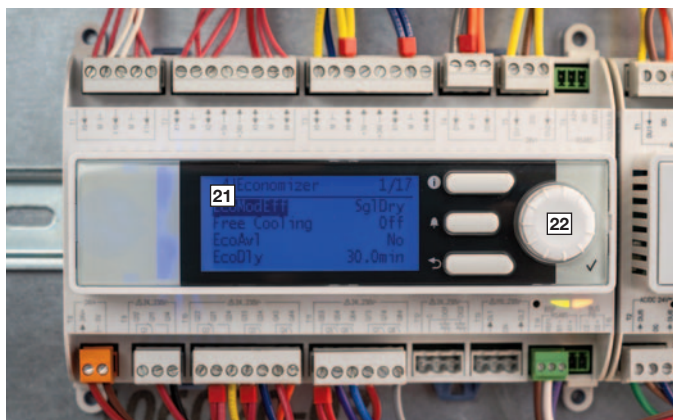

The RHPCYC with the Advanced Unitary Controller is specifically designed to be applied in three distinct applications:

- 1. BACnet Communication** — The RHPCYC is compatible with a third party building management system that supports the BACnet Application Specific Controller device profile, via standard BACnet IP or BACnet MS/TP communication. The controller communicated with either BACnet IP or BACnet MS/TP without additional communication modules. Communication with a BACnet application can be easily set up by navigating through the HMI.
- 2. 24VAC Thermostat Compatibility** — The RHPCYC is compatible with a programmable 24 volt thermostat. Connections are made via a dedicated 24VAC terminal block for easier field installation. Extensive unit status and diagnostics are displayed on the controller LCD screen.
- 3. Zone Sensor Compatibility** — The RHPCYC is compatible with the QMX3.P74 Zone Sensor. The zone sensor includes temperature, CO2, and humidity sensing with built in setpoint adjustment. To configure the zone sensor, navigate to the Zone Sensor menu in the controller menu tree. Extensive unit status and diagnostics are displayed on the controller LCD screen.

## Convenience Outlet, Disconnect & Circuit Breaker

The convenience outlet option comes non-powered from the factory (23). Low and high voltage can enter from the side or through the base. Low-voltage connections are made through the low-voltage terminal strip. For ease of access, the U.L.-required low voltage barrier can be temporarily removed for low-voltage termination and then reinstalled. The high-voltage connection is terminated at the number 1 compressor contactor. The suggested mounting for the field-installed disconnect or circuit breaker is on the exterior side of the electrical control box.



## External Lockable Gauge Ports

The unit's refrigerant gauge ports are mounted externally and include several features that enhance accessibility and serviceability. Accessed through a large, lockable door (24) so technicians have plenty of space to connect to the ports if needed, the external position allows for an accurate diagnostic of system operation without removing access panels which can affect unit performance. They are permanently identified by embossed lettering that identifies the high pressure connection and low pressure connection. The red plastic caps on the refrigerant ports (25) indicate unit is charged with A2L refrigerant.

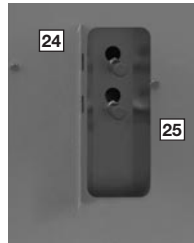

## Compressor

The compressor compartment houses the heartbeat of the unit. The scroll compressor (26) is known for its long life and for reliable, quiet, and efficient operation. The suction and discharge lines are designed with shock loops (27) to absorb the strain and stress that the starting torque, steady state operation, and shut-down cycle impose on the refrigerant tubing. 3-5 ton YB units include one single-stage compressor, and 6 ton YB units and 3-5 ton YC units include one two-stage compressor.



## Condenser Fans

The condenser fan motor controller (28) can easily be accessed and maintained through the top of the unit. A down-mount fan provides corrosion protection and removal. The polarized plug connection allows the motor controller to be changed quickly. The computational head is remotely mounted in the compressor section protected by the top panel to prevent exposure to weather and moisture.



## MicroChannel Condenser Technology

The outdoor coil uses the latest MicroChannel technology (29) for the most effective method of heat transfer. The outdoor coil is protected by optional louvered panels, which allow unobstructed airflow while protecting the unit from both the environment and vandalism.

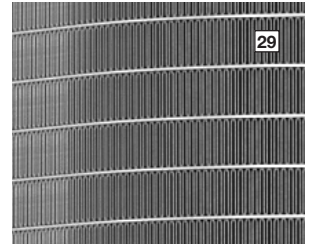

## Coil Coating

Every unit offers the option of factory-applied ElectroFin E-Coat condenser coating (30) that delivers superior corrosion resistance for outdoor coils to operate in the harshest of environments.



## Economizer and Dampers

Each unit is designed for both down flow or horizontal applications (31) for job configuration flexibility.

The return air compartment can also contain an economizer. Each unit is pre-wired for the economizer to allow quick, plug-in installation. Available as a factory-installed option, the economizer provides free cooling when outdoor conditions are suitable and also provides fresh air to meet local requirements. It comes standard with single enthalpy controls, which can be upgraded to dual enthalpy easily in the field. The economizer control has a minimum position set point, an outdoor-air set point, a mixed-air set point, and a CO<sub>2</sub> set point. Barometric relief is standard on all economizers.



Power Exhaust is easily field-installed. The power exhaust is housed in the barometric relief opening and is easily slipped in with a plugin assembly. The wire harness to the economizer also has accommodations for a smoke detector.

The damper minimum position, actual damper position, power exhaust on/off set point, mixed air temperature limit set point, and Demand Controlled Ventilation (DCV) set point can be read and adjusted at the unit controller display or remotely through a network connection. The Space CO<sub>2</sub> level, mixed air temperature, and Economizer Status (free cooling available, single or dual enthalpy) can be read at the unit controller display or remotely through a network connection. Economizer faults will trigger a network alarm and can be read at the unit controller display or remotely through a network connection.

## Roofcurb

The roofcurb (32) is made for tool-less assembly at the jobsite by engaging tabs in slots of adjacent curb sides, which makes the assembly process quick and easy.



## Refrigerant Leak Detection

In the event of a detected refrigerant leak, the refrigerant leak detection sensor (33) will trigger mitigation procedure that shuts off the compressor(s) and turns on the indoor blower motor.

The sensor is installed on the bracket facing the filter rack. From the outside of the unit, the sensor is not visible.

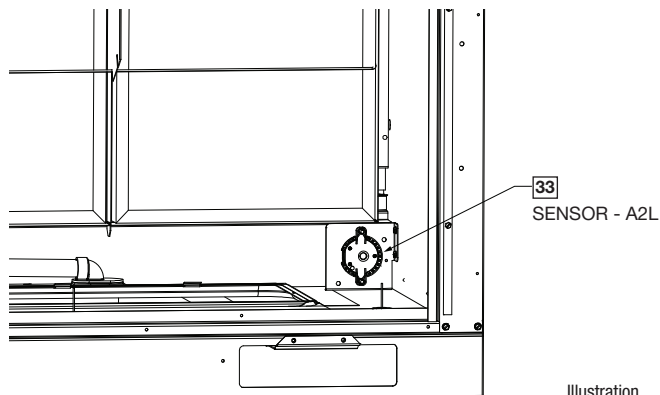

Illustration  
ST-A1291-21-00

**R** **HP** **C** **Y** **C** **036** **A** **C** **K** **10** **2** **E** **A** **\*\*\***  
**1** **23** **4** **5** **6** **789** **10** **11** **12** **13 14** **15** **16** **17** **18 19 20**

---

**1—Brand**

R = Ruud

**2, 3—Unit Type**

HP = Packaged HP

**4—Cabinet Type**

C = Small Commercial

**5—Refrigerant**

Y = R-454B

**6—Efficiency Level**

C = High Efficiency

**7, 8, 9—Capacity**

036 = 3 Ton

048 = 4 Ton

060 = 5 Ton

**10—Major Series**

A = 1st Design

**11—Voltage**

J = 1 PH, 208/230V, 60 Hz

C = 3 PH, 208/230V, 60 Hz

D = 3 PH, 460V, 60 Hz

**12—Drive**

K = Direct Drive Standard Static  
Constant Torque (02-10V)

L = Direct Drive High Static  
(0-10V)<sup>1</sup>

**13, 14—Heat Capacity**

00 = No Heat

10 = 10 kW

15 = 15 kW

20 = 20 kW

**15—Heat Configuration**

0 = No stages

1 = 1-stage

2 = 2-stage

**16—Control**

E = Advanced Unitary  
Controller

**17—Minor Series**

A = 1st Design

**18, 19, 20—Option Code**

See next page

---

<sup>1</sup>Only available on 5 ton

## FACTORY-INSTALLED OPTION CODES FOR RHPCYC (3-5 TON)

18				19			20				
LV = Louver protection				LF = Low Ambient & Freeze Stat			EC = Downflow Economizer				
HA = Hinged Access				NP = Non-powered Convenience Outlet			SS = Supply Smoke Detector				
CC <sup>1</sup> = Coil Coating							RS = Return Smoke Detector				
OPTION CODE CHARACTER HIGHLIGHTED BELOW											
A	None			A	None			0	None		
B	LV			B	LF			1	EC		
C	HA			C	NP			2	RS		
D	LV	HA		D	LF	NP		3	EC	RS	
E	LV	CC						4	SS	RS	
F	LV	HA	CC					5	EC	SS	RS

<sup>1</sup> CC requires LV (louver protection)

### Instructions for Factory-Installed Option(s) Selection

**Note:** Three characters following the model number will be utilized to designate a factory-installed option or combination of options. If no factory option(s) is required, "AA0" follows the model number.

- **Step 1:** In the table above, based on the desired features, choose option code character from highlighted options on the left side under the number 18. For example, the option code character "E" has Louver protection and Coil Coating.
- **Step 2:** In the table above, based on the desired features, choose option code character from highlighted options on the left side under the number 19. For example, the option code character "D" has Low Ambient & Freeze Stat and a Non-powered Convenience Outlet.
- **Step 3:** In the table above, based on the desired features, choose option code character from highlighted options on the left side under the number 20. For example, the option code character "3" has Downflow Economizer and Return Smoke.
- The resulting option code from examples above is: "EF3"
- **Step 4:** Add your option code selection to the end of model number

◦ Example: RHPCYC036ACK000EA      ED3      =      RHPCYC036ACK000EAED3

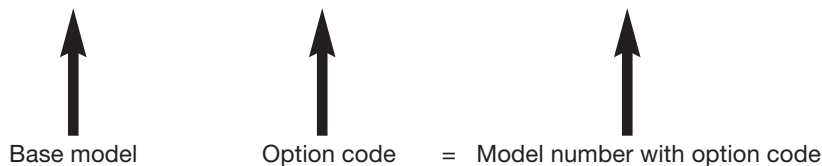

To select an RHPCYC Heat Pump to meet a job requirement, follow this procedure, with example, using data supplied in this specification sheet.

**1. DETERMINE COOLING AND HEATING REQUIREMENTS AND SPECIFIC OPERATING CONDITIONS FROM PLANS AND SPECS.**

**Example:**

Voltage—	230 V – 3 Phase – 60 Hz
Total Cooling Capacity—	47,000 Btu/h [13.8 kW]
Sensible Cooling Capacity—	36,000 Btu/h [10.6 kW]
Heating Capacity—	40,000 Btu/h [10 kW]
*Condenser Entering Air—	95°F [35.0°C] DB
*Evaporator Mixed Air Entering—	67°F [19.4°C] WB
	78°F [25.6°C] DB
*Indoor Air Flow (vertical)—	1600 CFM [755 L/s]
*External Static Pressure—	0.6 in. WG [15 kPa]

**2. SELECT UNIT TO MEET COOLING REQUIREMENTS.**

Since total cooling is within range of a nominal 4-ton unit, use the cooling performance table at 95°F DB condenser inlet air. Interpolate between 2050 CFM [967 L/s] and 1575 CFM [743 L/s] to determine total and sensible capacity and Depression Ratio for inlet air at 1600CFM [755 L/s] indoor airflow (table basis)

Interpolation Formula:

$$MBH_1 + \left[ (CFM - CFM_1) \times \left( \frac{MBH_2 - MBH_1}{CFM_2 - CFM_1} \right) \right] = MBH$$

Total Cooling Capacity:

$$54,300 + \left[ (1,600 - 2,050) \times \left( \frac{51,500 - 54,300}{1,575 - 2,050} \right) \right] = 51,648 \text{ Btu/h}$$

Total Cooling Capacity = 51,650 Btu/h [15.1 kW]  
Sensible Cooling Capacity = 37,775 Btu/h [11.1 kW]  
DR = 0.09

When the entering dry bulb temperature (dbE) is not 80°F [26.7°C], the sensible capacity needs to be adjusted.

Note: total capacity is unaffected

Sensible Capacity Depression Formula:

$$Cap_{sensible} + [1.10 \times CFM \times (1 - DR) \times (dbE - 80)]$$

$$= 37,775 + [1.10 \times 1,600 \times (1 - 0.09) \times (78 - 80)]$$

$$\text{Sensible Cooling Capacity} = 34,570 \text{ Btu/h [10.1 kW]}$$

**3. DETERMINE BLOWER SPEED AND BHP TO MEET SYSTEM DESIGN.**

Total ESP (external static pressure) per the spec of 0.6 in WG [15 kPa] includes the system duct and grilles. Add from the table “Component Air Resistance,” 0.09 in. WG [0.02 kPa] for wet coil. Using the “Airflow Performance Table”, at the specified 1,600 CFM and 0.7 in. WG [0.17 kPa] ESP, determine blower wattage.

CFM = 1600  
Watts = 487  
% VDC = 57.0

**4. CALCULATE INDOOR BLOWER BTU/H HEAT EFFECT FROM MOTOR BHP IN STEP 3.**

Assuming an average of 85% motor efficiency, determine the amount of heat generated by the blower motor at the specified CFM and ESP by dividing the watts used by the motor efficiency and solving for the difference. Convert this value from watts to Btu/h, multiplying by 3.41 Btu/h/Watt

Watts = 487

Avg. Motor Efficiency = 85%

$$\text{Indoor Blower Motor Heat} = \left[ \left( \frac{\text{Watts}}{0.85} \right) - \text{Watts} \right] \times 3.41$$

$$= [(487/0.85) - 487] \times 3.41 = 290 \text{ Btu/h [0.02 kW]}$$

**5. CALCULATE THE NET COOLING CAPACITIES**

Net cooling capacities can be calculated by subtracting the motor heat from the gross cooling capacities.

Net Total Capacity = Gross Total Capacity – Indoor Blower Motor Heat

$$= 51,650 - 290 = 51,360 \text{ Btu/h [15.1 kW]}$$

Net Sensible Capacity = Gross Sensible Capacity – Indoor Blower Motor Heat

$$= 37,775 - 290 = 37,485 \text{ Btu/h [11.0 kW]}$$

**6. CHOOSE MODEL RHPCYC048ACK**

[ ] Designates Metric Conversions

## GENERAL DATA—RHPCYC MODELS—3-5 TON

Model RHPCYC Series	036ACK 036AJK	036ADK	048ACK 048AJK
<b>Cooling Performance<sup>A</sup></b>			<b>CONTINUED</b> →
Nominal Cooling Capacity Btu/h [kW]	36,000 [10.55]	36,000 [10.55]	48,000 [14.07]
EER <sup>2B</sup>	11.0	11.0	11.0
SEER <sup>2B</sup>	16.1	16.1	16.1
Nominal CFM [L/s]	1,200 [566]	1,200 [566]	1,600 [755]
AHRI Rated CFM [L/s]	1,175 [555]	1,175 [555]	1,565 [739]
AHRI Net Cooling Capacity Btu/h [kW]	34,200 [10.02]	34,200 [10.02]	45,500 [13.34]
Net Sensible Capacity Btu/h [kW]	27,360 [7.93]	27,360 [7.93]	36,400 [10.56]
Net Latent Capacity Btu/h [kW]	6,840 [1.98]	6,840 [1.98]	9,100 [2.64]
Net System Power kW	3.1	3.1	4.1
<b>Heating Performance (Heat Pumps)</b>			
High Temp. Btu/h [kW] Rating @ 47°F	34,200 [10.02]	34,200 [10.02]	45,500 [13.34]
System Power kW/COP @ 47°F	2.8/3.6	2.8/3.6	3.6/3.6
Low Temp. Btu/h [kW] Rating @ 17°F	21,400 [6.27]	21,400 [6.27]	27,800 [8.15]
System Power kW/COP @ 17°F	2.73/2.30	2.73/2.30	4.07/2.00
HSPF2 (Btu/Watts-hr)	7.2	7.2	7.2
<b>Compressor</b>			
No./Stage/Type	1/2/Scroll	1/2/Scroll	1/2/Scroll
<b>Outdoor Sound Rating (dB)<sup>D</sup></b>	82	82	78
<b>Outdoor Coil - Fin Type</b>	Louvered	Louvered	Louvered
Tube Type	MicroChannel	MicroChannel	MicroChannel
MicroChannel Depth in. [mm]	1.26 [32]	1.26 [32]	1.26 [32]
Face Area sq. ft. [sq. m]	16.11 [1.50]	16.11 [1.50]	16.11 [1.50]
Rows/FPI [FPcm]	1/16 [6]	1/16 [6]	1/16 [6]
Refrigerant Control	TXV	TXV	TXV
<b>Indoor Coil - Fin Type</b>	Louvered	Louvered	Louvered
Tube Type	MicroChannel	MicroChannel	MicroChannel
MicroChannel Depth in. [mm]	1.26 [32]	1.26 [32]	1.26 [32]
Face Area sq. ft. [sq. m]	7.47 [0.69]	7.47 [0.69]	7.47 [0.69]
Rows/FPI [FPcm]	1 / 20 [50.80]	1 / 20 [50.80]	1 / 20 [50.80]
Refrigerant Control	TXV	TXV	TXV
Drain Connection No./Size in. [mm]	1/0.75 [19.05]	1/0.75 [19.05]	1/0.75 [19.05]
<b>Outdoor Fan - Type</b>	ECM / Propeller	ECM / Propeller	ECM / Propeller
No. Used/Diameter in. [mm]	1/26 [660.4]	1/26 [660.4]	1/26 [660.4]
Drive Type/No. Speeds	Direct/Multiple	Direct/Multiple	Direct/Multiple
CFM [L/s]	1,440 [6,796]	1,440 [6,796]	1,920 [9,061]
No. Motors at HP	1 at 1/2 HP	1 at 1/2 HP	1 at 1/2 HP
Motor RPM	1,200	1,140	1,200
<b>Indoor Fan - Type</b>	FC Centrifugal	FC Centrifugal	FC Centrifugal
No. Used/Wheel Diameter x Width in. [mm]	1/11x11 [279x279]	1/11x11 [279x279]	1/11x11 [279x279]
Drive Type	Direct	Direct	Direct
No. Speeds	Multiple	Multiple	Multiple
No. Motors	1	1	1
Motor HP	1	1	1
Motor RPM	1,400	1,400	1,400
Motor Frame Size	48	48	48
<b>Filter - Type</b>	Disposable	Disposable	Disposable
Furnished	Yes	Yes	Yes
(NO.) Size Recommended in. [mm x mm x mm]	(4)2x16x16 [51x406x406]	(4)2x16x16 [51x406x406]	(4)2x16x16 [51x406x406]
<b>Refrigerant Charge Oz. [g]</b>	155 [4,394]	155 [4,394]	155 [4,394]
<b>Weights</b>			
Net Weight lbs. [kg]	562 [245]	562 [245]	562 [245]
Ship Weight lbs. [kg]	600 [262]	600 [262]	600 [262]

See Page 16 for Notes.

[ ] Designates Metric Conversions

## GENERAL DATA—RHPCYC MODELS—3-5 TON

Model RHPCYC Series	048ADK	060ACK 060AJK	060ADK
<b>Cooling Performance<sup>A</sup></b>			<b>CONTINUED</b>
Nominal Cooling Capacity Btu/h [kW]	48,000 [14.07]	60,000 [17.58]	60,000 [17.58]
EER <sup>2B</sup>	11.0	11.0	11.0
SEER <sup>2B</sup>	16.1	16.1	16.1
Nominal CFM [L/s]	1,600 [755]	2,000 [944]	2,000 [944]
AHRI Rated CFM [L/s]	1,565 [739]	1,960 [925]	1,960 [925]
AHRI Net Cooling Capacity Btu/h [kW]	45,500 [13.34]	57,000 [16.71]	57,000 [16.71]
Net Sensible Capacity Btu/h [kW]	36,400 [10.56]	45,600 [13.22]	45,600 [13.22]
Net Latent Capacity Btu/h [kW]	9,100 [2.64]	11,400 [3.31]	11,400 [3.31]
Net System Power kW	4.1	5.2	5.2
<b>Heating Performance (Heat Pumps)</b>			
High Temp. Btu/h [kW] Rating @ 47°F	45,500 [13.34]	56,000 [16.41]	56,000 [16.41]
System Power kW/COP @ 47°F	3.6/3.6	4.3/3.6	4.3/3.6
Low Temp. Btu/h [kW] Rating @ 17°F	27,800 [8.15]	30,600 [8.97]	30,600 [8.97]
System Power kW/COP @ 17°F	4.07/2.00	4.11/2.18	4.11/2.18
HSPF2 (Btu/Watts-hr)	7.2	7.2	7.2
<b>Compressor</b>			
No./Stage/Type	1/2/Scroll	1/2/Scroll	1/2/Scroll
<b>Outdoor Sound Rating (dB)<sup>D</sup></b>	78	85	85
<b>Outdoor Coil - Fin Type</b>	Louvered	Louvered	Louvered
Tube Type	MicroChannel	MicroChannel	MicroChannel
MicroChannel Depth in. [mm]	1.26 [32]	1.26 [32]	1.26 [32]
Face Area sq. ft. [sq. m]	16.11 [1.50]	16.11 [1.50]	16.11 [1.50]
Rows/FPI [FPcm]	1/16 [6]	1/16 [6]	1/16 [6]
Refrigerant Control	TXV	TXV	TXV
<b>Indoor Coil - Fin Type</b>	Louvered	Louvered	Louvered
Tube Type	MicroChannel	MicroChannel	MicroChannel
MicroChannel Depth in. [mm]	1.26 [32]	1.26 [32]	1.26 [32]
Face Area sq. ft. [sq. m]	7.47 [0.69]	7.47 [0.69]	7.47 [0.69]
Rows/FPI [FPcm]	1 / 20 [50.80]	1 / 20 [50.80]	1 / 20 [50.80]
Refrigerant Control	TXV	TXV	TXV
Drain Connection No./Size in. [mm]	1/0.75 [19.05]	1/0.75 [19.05]	1/0.75 [19.05]
<b>Outdoor Fan - Type</b>	ECM / Propeller	ECM / Propeller	ECM / Propeller
No. Used/Diameter in. [mm]	1/26 [660.4]	1/26 [660.4]	1/26 [660.4]
Drive Type/No. Speeds	Direct/Multiple	Direct/Multiple	Direct/Multiple
CFM [L/s]	1,920 [9,061]	2,400 [11,327]	2,400 [11,327]
No. Motors at HP	1 at 1/2 HP	1 at 1/2 HP	1 at 1/2 HP
Motor RPM	1,200	1,200	1,200
<b>Indoor Fan - Type</b>	FC Centrifugal	FC Centrifugal	FC Centrifugal
No. Used/Wheel Diameter x Width in. [mm]	1/11x11 [279x279]	1/11x11 [279x279]	1/11x11 [279x279]
Drive Type	Direct	Direct	Direct
No. Speeds	Multiple	Multiple	Multiple
No. Motors	1	1	1
Motor HP	1	1	1
Motor RPM	1,400	1,400	1,400
Motor Frame Size	48	48	48
<b>Filter - Type</b>	Disposable	Disposable	Disposable
Furnished	Yes	Yes	Yes
(NO.) Size Recommended in. [mm x mm x mm]	(4)2x16x16 [51x406x406]	(4)2x16x16 [51x406x406]	(4)2x16x16 [51x406x406]
<b>Refrigerant Charge Oz. [g]</b>	155 [4,394]	154.5 [4,380]	154.5 [4,380]
<b>Weights</b>			
Net Weight lbs. [kg]	562 [245]	562 [245]	562 [245]
Ship Weight lbs. [kg]	600 [262]	600 [262]	600 [262]

See Page 16 for Notes.

[ ] Designates Metric Conversions

## GENERAL DATA—RHPCYC MODELS—3-5 TON

Model RHPCYC Series	060ACL 060AJL	060ADL
<b>Cooling Performance<sup>A</sup></b>		
Nominal Cooling Capacity Btu/h [kW]	60,000 [17.58]	60,000 [17.58]
EER <sup>2B</sup>	11.0	11.0
SEER <sup>2B</sup>	16.1	16.1
Nominal CFM [L/s]	2,000 [944]	2,000 [944]
AHRI Rated CFM [L/s]	1,960 [925]	1,960 [925]
AHRI Net Cooling Capacity Btu/h [kW]	57,000 [16.71]	57,000 [16.71]
Net Sensible Capacity Btu/h [kW]	45,600 [13.22]	45,600 [13.22]
Net Latent Capacity Btu/h [kW]	11,400 [3.31]	11,400 [3.31]
Net System Power kW	5.2	5.2
<b>Heating Performance (Heat Pumps)</b>		
High Temp. Btu/h [kW] Rating @ 47°F	56,000 [16.41]	56,000 [16.41]
System Power kW/COP @ 47°F	4.3/3.6	4.3/3.6
Low Temp. Btu/h [kW] Rating @ 17°F	30,600 [8.97]	30,600 [8.97]
System Power kW/COP @ 17°F	4.11/2.18	4.11/2.18
HSPF2 (Btu/Watts-hr)	7.2	7.2
<b>Compressor</b>		
No./Stage/Type	1/2/Scroll	1/2/Scroll
<b>Outdoor Sound Rating (dB)<sup>D</sup></b>		
	85	85
<b>Outdoor Coil - Fin Type</b>		
Tube Type	Louvered	Louvered
MicroChannel Depth in. [mm]	MicroChannel	MicroChannel
Face Area sq. ft. [sq. m]	1.26 [32]	1.26 [32]
Rows/FPI [FPcm]	16.11 [1.50]	16.11 [1.50]
Refrigerant Control	1/16 [6]	1/16 [6]
	TXV	TXV
<b>Indoor Coil - Fin Type</b>		
Tube Type	Louvered	Louvered
MicroChannel Depth in. [mm]	MicroChannel	MicroChannel
Face Area sq. ft. [sq. m]	1.26 [32]	1.26 [32]
Rows/FPI [FPcm]	7.47 [0.69]	7.47 [0.69]
Refrigerant Control	1 / 20 [50.80]	1 / 20 [50.80]
Drain Connection No./Size in. [mm]	TXV	TXV
	1/0.75 [19.05]	1/0.75 [19.05]
<b>Outdoor Fan - Type</b>		
No. Used/Diameter in. [mm]	ECM / Propeller	ECM / Propeller
Drive Type/No. Speeds	1/26 [660.4]	1/26 [660.4]
CFM [L/s]	Direct/Multiple	Direct/Multiple
No. Motors at HP	2,400 [11,327]	2,400 [11,327]
Motor RPM	1 at 1/2 HP	1 at 1/2 HP
	1,200	1,200
<b>Indoor Fan - Type</b>		
No. Used/Wheel Diameter x Width in. [mm]	FC Centrifugal	FC Centrifugal
Drive Type	1/11x11 [279x279]	1/11x11 [279x279]
No. Speeds	Direct	Direct
No. Motors	Multiple	Multiple
Motor HP	1	1
Motor RPM	1.5	1.5
Motor Frame Size	1,600	1,600
	48	48
<b>Filter - Type</b>		
Furnished	Disposable	Disposable
(NO.) Size Recommended in. [mm x mm x mm]	Yes	Yes
	(4)2x16x16 [51x406x406]	(4)2x16x16 [51x406x406]
<b>Refrigerant Charge Oz. [g]</b>		
	154.5 [4,380]	154.5 [4,380]
<b>Weights</b>		
Net Weight lbs. [kg]	562 [245]	562 [245]
Ship Weight lbs. [kg]	600 [262]	600 [262]

See Page 16 for Notes.

[ ] Designates Metric Conversions

**NOTES:**

- A. Cooling Performance is rated at 95°F ambient, 80°F entering dry bulb, 67°F entering wet bulb. Gross capacity does not include the effect of fan motor heat. AHRI capacity is net and includes the effect of fan motor heat. Units are suitable for operation to ± 20% of nominal CFM. Units are certified in accordance with the Unitary Air Conditioner Equipment certification program, which is based on AHRI Standard 210/240.
- B. EER/EER2 and/or SEER2 are rated at AHRI conditions in accordance with DOE test procedures.
- C. Integrated Energy Efficiency Ratio (IEER) is rated in accordance with AHRI Standard 340/360.
- D. Outdoor Sound Rating shown is tested in accordance with AHRI Standard 270.

**WEIGHTED SOUND POWER LEVEL (dBA)**

Model	Standard Rating (dBA)	Frequency (Hz)						
		125	250	500	1000	2000	4000	8000
RHPCYC036	82.4	62.2	69.4	73.0	72.2	68.8	64.2	58.5
RHPCYC048	77.8	66.6	64.5	66.6	69.3	64.6	59.1	54.4
RHPCYC060	84.9	59.7	73.3	75.5	74.7	71.2	66.3	59.7

Outdoor Sound Rating shown is tested in accordance with AHRI Standard 270.

## COOLING PERFORMANCE DATA—RHPCYC036

		ENTERING INDOOR AIR @ 80°F [26.7°C] dbE ①									
		wbE	71°F [21.7°C]			67°F [19.4°C]			63°F [17.2°C]		
		CFM [L/s]	1575 [743]	1175 [555]	1050 [496]	1575 [743]	1175 [555]	1050 [496]	1575 [743]	1175 [555]	1050 [496]
		DR ①	.05	.09	.12	.05	.09	.12	.05	.09	.12
O U T D O O R  D R Y  B U L B  T E M P E R A T U R E  ° F [ ° C]	75°F [23.9°C]	Total kBtu/h [kW] Sens kBtu/h [kW] Power	50.3 [14.7] 30.4 [8.9] 2.4	47.4 [13.9] 26.2 [7.7] 2.4	46.5 [13.6] 24.9 [7.3] 2.3	46.5 [13.6] 34.9 [10.2] 2.4	43.8 [12.8] 30.1 [8.8] 2.3	42.9 [12.6] 28.6 [8.4] 2.3	42.8 [12.5] 40.0 [11.7] 2.4	40.3 [11.8] 34.5 [10.1] 2.3	39.5 [11.6] 32.8 [9.6] 2.3
	80°F [26.7°C]	Total kBtu/h [kW] Sens kBtu/h [kW] Power	49.2 [14.4] 29.7 [8.7] 2.6	46.3 [13.6] 25.7 [7.5] 2.5	45.4 [13.3] 24.4 [7.2] 2.5	45.4 [13.3] 34.3 [10.1] 2.5	42.7 [12.5] 29.6 [8.7] 2.5	41.9 [12.3] 28.1 [8.2] 2.4	41.7 [12.2] 39.4 [11.5] 2.5	39.3 [11.5] 34.0 [10.0] 2.4	38.5 [11.3] 32.3 [9.5] 2.4
	85°F [29.4°C]	Total kBtu/h [kW] Sens kBtu/h [kW] Power	48.0 [14.1] 29.1 [8.5] 2.7	45.2 [13.2] 25.1 [7.4] 2.6	44.3 [13] 23.9 [7.0] 2.6	45.4 [13.3] 34.3 [10.1] 2.5	41.6 [12.2] 29.0 [8.5] 2.6	40.8 [12.0] 27.6 [8.1] 2.6	40.5 [11.9] 38.7 [11.3] 2.6	38.2 [11.2] 33.4 [9.8] 2.6	37.4 [11.0] 31.8 [9.3] 2.5
	90°F [32.2°C]	Total kBtu/h [kW] Sens kBtu/h [kW] Power	46.8 [13.7] 28.5 [8.4] 2.8	44.0 [12.9] 24.6 [7.2] 2.7	43.2 [12.7] 23.4 [6.9] 2.7	43.0 [12.6] 33.0 [9.7] 2.8	40.5 [11.9] 28.5 [8.4] 2.7	39.7 [11.6] 27.1 [7.9] 2.7	39.3 [11.5] 38.1 [11.2] 2.8	37.0 [10.8] 32.9 [9.6] 2.7	36.3 [10.6] 31.3 [9.2] 2.7
	95°F [35°C]	Total kBtu/h [kW] Sens kBtu/h [kW] Power	45.4 [13.3] 27.9 [8.2] 3.0	42.8 [12.5] 24.1 [7.1] 2.9	42.0 [12.3] 22.9 [6.7] 2.9	41.6 [12.2] 32.4 [9.5] 2.9	39.2 [11.5] 28.0 [8.2] 2.9	38.5 [11.3] 26.6 [7.8] 2.8	38.0 [11.1] 37.5 [11.0] 2.9	35.7 [10.5] 32.4 [9.5] 2.8	35.1 [10.3] 30.8 [9.0] 2.8
	100°F [37.8°C]	Total kBtu/h [kW] Sens kBtu/h [kW] Power	44.1 [12.9] 27.3 [8.0] 3.1	41.5 [12.2] 23.6 [6.9] 3.0	40.7 [11.9] 22.4 [6.6] 3.0	40.3 [11.8] 31.8 [9.3] 3.1	37.9 [11.1] 27.5 [8.1] 3.0	37.2 [10.9] 26.1 [7.6] 3.0	36.6 [10.7] 36.6 [10.7] 3.1	34.4 [10.1] 31.8 [9.3] 3.0	33.8 [9.9] 30.3 [8.9] 3.0
	105°F [40.6°C]	Total kBtu/h [kW] Sens kBtu/h [kW] Power	42.6 [12.5] 26.7 [7.8] 3.3	40.1 [11.8] 23.0 [6.7] 3.2	39.4 [11.5] 21.9 [6.4] 3.2	38.8 [11.4] 31.2 [9.1] 3.3	36.6 [10.7] 27.0 [7.9] 3.2	35.9 [10.5] 25.6 [7.5] 3.2	35.1 [10.3] 35.1 [10.3] 3.3	33.1 [9.7] 31.3 [9.2] 3.2	32.4 [9.5] 29.8 [8.7] 3.1
	110°F [43.3°C]	Total kBtu/h [kW] Sens kBtu/h [kW] Power	41.1 [12.0] 26.1 [7.6] 3.5	38.7 [11.3] 22.5 [6.6] 3.4	38.0 [11.1] 21.4 [6.3] 3.4	37.3 [10.9] 30.7 [9.0] 3.5	35.1 [10.3] 26.5 [7.8] 3.4	34.5 [10.1] 25.1 [7.4] 3.3	33.6 [9.8] 33.6 [9.8] 3.4	31.7 [9.3] 30.8 [9.0] 3.3	31.0 [9.1] 29.3 [8.6] 3.3
	115°F [46.1°C]	Total kBtu/h [kW] Sens kBtu/h [kW] Power	39.5 [11.6] 25.5 [7.5] 3.7	37.2 [10.9] 22.0 [6.4] 3.6	36.5 [10.7] 20.9 [6.1] 3.5	35.7 [10.5] 30.1 [8.8] 3.6	33.6 [9.8] 26.0 [7.6] 3.5	33.0 [9.7] 24.7 [7.2] 3.5	32.0 [9.4] 32.0 [9.4] 3.6	30.2 [8.9] 30.2 [8.9] 3.5	29.6 [8.7] 28.8 [8.4] 3.5
	120°F [48.9°C]	Total kBtu/h [kW] Sens kBtu/h [kW] Power	37.9 [11.1] 25.0 [7.3] 3.9	35.7 [10.5] 21.5 [6.3] 3.8	35.0 [10.3] 20.5 [6.0] 3.7	34.1 [10.0] 29.5 [8.6] 3.8	32.1 [9.4] 25.5 [7.5] 3.7	31.5 [9.2] 24.2 [7.1] 3.7	30.4 [8.9] 30.4 [8.9] 3.8	28.6 [8.4] 28.6 [8.4] 3.7	28.1 [8.2] 28.1 [8.2] 3.7
	125°F [51.7°C]	Total kBtu/h [kW] Sens kBtu/h [kW] Power	36.2 [10.6] 24.4 [7.2] 4.1	34.1 [10.0] 21.1 [6.2] 4.0	33.4 [9.8] 20.0 [5.9] 3.9	32.4 [9.5] 28.9 [8.5] 4.1	30.5 [8.9] 25.0 [7.3] 3.9	29.9 [8.8] 23.7 [6.9] 3.9	28.7 [8.4] 28.7 [8.4] 4.0	27.0 [7.9] 27.0 [7.9] 3.9	26.5 [7.8] 26.5 [7.8] 3.9

DR —Depression ratio  
dbE —Entering air dry bulb  
wbE —Entering air wet bulb  
Power —kW input

NOTES: ① When the entering air dry bulb is other than 80°F [27°C], adjust the sensible capacity from the table by adding [1.10 x CFM x (1 - DR) x (dbE - 80)].

[ ] Designates Metric Conversions

## COOLING PERFORMANCE DATA – RHPCYC048

		ENTERING INDOOR AIR @ 80°F [26.7°C] dbE ①									
wbE		71°F [21.7°C]			67°F [19.4°C]			63°F [17.2°C]			
CFM [L/s]		2050 [967]	1575 [743]	1375 [649]	2050 [967]	1575 [743]	1375 [649]	2050 [967]	1575 [743]	1375 [649]	
DR ①		.05	.09	.12	.05	.09	.12	.05	.09	.12	
O U T D O O R  D R Y  B U L B  T E M P E R A T U R E  °F [°C]	75°F [23.9°C]	Total kBtu/h [kW] Sens kBtu/h [kW] Power	64.6 [18.9] 39.0 [11.4] 3.1	61.2 [17.9] 34.2 [10.0] 3.1	59.8 [17.5] 32.2 [9.4] 3.0	60.6 [17.8] 45.8 [13.4] 3.1	57.4 [16.8] 40.2 [11.8] 3.1	56.1 [16.4] 37.8 [11.1] 3.0	56.6 [16.6] 52.7 [15.4] 3.1	53.6 [15.7] 46.2 [13.5] 3.0	52.4 [15.4] 43.4 [12.7] 3.0
	80°F [26.7°C]	Total kBtu/h [kW] Sens kBtu/h [kW] Power	63.0 [18.5] 38.2 [11.2] 3.3	59.7 [17.5] 33.5 [9.8] 3.3	58.4 [17.1] 31.5 [9.2] 3.2	59.0 [17.3] 45.1 [13.2] 3.3	55.9 [16.4] 39.5 [11.6] 3.3	54.6 [16.0] 37.2 [10.9] 3.2	55.0 [16.1] 51.9 [15.2] 3.3	52.1 [15.3] 45.5 [13.3] 3.2	50.9 [14.9] 42.8 [12.5] 3.1
	85°F [29.4°C]	Total kBtu/h [kW] Sens kBtu/h [kW] Power	61.4 [18.0] 37.5 [11.0] 3.5	58.2 [17.1] 32.8 [9.6] 3.4	56.9 [16.7] 30.9 [9.1] 3.4	57.4 [16.8] 44.3 [13.0] 3.5	54.4 [15.9] 38.8 [11.4] 3.4	53.2 [15.6] 36.5 [10.7] 3.4	53.4 [15.7] 51.1 [15.0] 3.5	50.6 [14.8] 44.8 [13.1] 3.4	49.5 [14.5] 42.1 [12.3] 3.3
	90°F [32.2°C]	Total kBtu/h [kW] Sens kBtu/h [kW] Power	59.9 [17.6] 36.7 [10.8] 3.7	56.8 [16.6] 32.2 [9.4] 3.6	55.4 [16.2] 30.2 [8.9] 3.6	55.9 [16.4] 43.5 [12.7] 3.7	53.0 [15.5] 38.1 [11.2] 3.6	51.7 [15.2] 35.9 [10.5] 3.6	51.8 [15.2] 50.3 [14.7] 3.7	49.2 [14.4] 44.1 [12.9] 3.6	48.0 [14.1] 41.5 [12.2] 3.5
	95°F [35°C]	Total kBtu/h [kW] Sens kBtu/h [kW] Power	58.3 [17.1] 35.9 [10.5] 3.9	55.3 [16.2] 31.5 [9.2] 3.8	54.0 [15.8] 29.6 [8.7] 3.8	54.3 [15.9] 42.7 [12.5] 3.9	51.5 [15.1] 37.5 [11.0] 3.8	50.3 [14.7] 35.2 [10.3] 3.8	50.3 [14.7] 49.6 [14.5] 3.9	47.7 [14.0] 43.4 [12.7] 3.8	46.6 [13.7] 40.9 [12.0] 3.7
	100°F [37.8°C]	Total kBtu/h [kW] Sens kBtu/h [kW] Power	56.7 [16.6] 35.1 [10.3] 4.1	53.8 [15.8] 30.8 [9.0] 4.0	52.5 [15.4] 29.0 [8.5] 4.0	52.7 [15.4] 42.0 [12.3] 4.1	50.0 [14.7] 36.8 [10.8] 4.0	48.8 [14.3] 34.6 [10.1] 4.0	48.7 [14.3] 48.7 [14.3] 4.1	46.2 [13.5] 42.8 [12.5] 3.9	45.1 [13.2] 40.2 [11.8] 3.9
	105°F [40.6°C]	Total kBtu/h [kW] Sens kBtu/h [kW] Power	55.2 [16.2] 34.4 [10.1] 4.3	52.3 [15.3] 30.1 [8.8] 4.2	51.1 [15.0] 28.3 [8.3] 4.2	51.1 [15.0] 41.2 [12.1] 4.3	48.5 [14.2] 36.1 [10.6] 4.2	47.4 [13.9] 34.0 [10.0] 4.2	47.1 [13.8] 47.1 [13.8] 4.2	44.7 [13.1] 42.1 [12.3] 4.1	43.7 [12.8] 39.6 [11.6] 4.1
	110°F [43.3°C]	Total kBtu/h [kW] Sens kBtu/h [kW] Power	53.6 [15.7] 33.6 [9.8] 4.5	50.8 [14.9] 29.4 [8.6] 4.4	49.6 [14.5] 27.7 [8.1] 4.4	49.6 [14.5] 40.4 [11.8] 4.5	47.0 [13.8] 35.4 [10.4] 4.4	45.9 [13.5] 33.3 [9.8] 4.4	45.6 [13.4] 45.6 [13.4] 4.4	43.2 [12.7] 41.4 [12.1] 4.3	42.2 [12.4] 39.0 [11.4] 4.3
	115°F [46.1°C]	Total kBtu/h [kW] Sens kBtu/h [kW] Power	52.0 [15.2] 32.8 [9.6] 4.7	49.3 [14.4] 28.8 [8.4] 4.6	48.2 [14.1] 27.1 [7.9] 4.5	48.0 [14.1] 39.6 [11.6] 4.7	45.5 [13.3] 34.8 [10.2] 4.6	44.5 [13.0] 32.7 [9.6] 4.5	44.0 [12.9] 44.0 [12.9] 4.6	41.7 [12.2] 40.7 [11.9] 4.5	40.7 [11.9] 38.3 [11.2] 4.5
	120°F [48.9°C]	Total kBtu/h [kW] Sens kBtu/h [kW] Power	50.4 [14.8] 32.0 [9.4] 4.9	47.8 [14.0] 28.1 [8.2] 4.8	46.7 [13.7] 26.4 [7.7] 4.7	46.4 [13.6] 38.9 [11.4] 4.9	44.0 [12.9] 34.1 [10.0] 4.8	43.0 [12.6] 32.1 [9.4] 4.7	42.4 [12.4] 42.4 [12.4] 4.8	40.2 [11.8] 40.1 [11.8] 4.7	39.3 [11.5] 37.7 [11.0] 4.7
	125°F [51.7°C]	Total kBtu/h [kW] Sens kBtu/h [kW] Power	48.9 [14.3] 31.3 [9.2] 5.1	46.3 [13.6] 27.4 [8.0] 5.0	45.3 [13.3] 25.8 [7.6] 4.9	44.9 [13.2] 38.1 [11.2] 5.1	42.5 [12.5] 33.4 [9.8] 5.0	41.5 [12.2] 31.4 [9.2] 4.9	40.8 [12.0] 40.8 [12.0] 5.0	38.7 [11.3] 38.7 [11.3] 4.9	37.8 [11.1] 37.0 [10.8] 4.9

DR —Depression ratio  
dbE —Entering air dry bulb

wbE—Entering air wet bulb  
Power—kW input

NOTES: ① When the entering air dry bulb is other than 80°F [27°C], adjust the sensible capacity from the table by adding [1.10 x CFM x (1 – DR) x (dbE – 80)].

[ ] Designates Metric Conversions

## COOLING PERFORMANCE DATA—RHPCYC060

ENTERING INDOOR AIR @ 80°F [26.7°C] dbE ①											
wbE		71°F [21.7°C]			67°F [19.4°C]			63°F [17.2°C]			
CFM [L/s]		2425 [1144]	1950 [920]	1600 [755]	2425 [1144]	1950 [920]	1600 [755]	2425 [1144]	1950 [920]	1600 [755]	
DR ①		.05	.09	.12	.05	.09	.12	.05	.09	.12	
O U T D O O R  D R Y  B U L B  T E M P E R A T U R E  ° F [ ° C]	75°F [23.9°C]	Total kBtu/h [kW]	77.0 [22.6]	73.8 [21.6]	71.3 [20.9]	71.4 [20.9]	68.3 [20.0]	66.1 [19.4]	65.7 [19.3]	62.9 [18.4]	60.9 [17.8]
		Sens kBtu/h [kW]	45.6 [13.4]	41.0 [12.0]	37.5 [11.0]	54.2 [15.9]	48.7 [14.3]	44.6 [13.1]	62.9 [18.4]	56.5 [16.6]	51.7 [15.2]
		Power	4.1	4.0	3.9	4.1	4.0	3.9	4.0	4.0	3.9
	80°F [26.7°C]	Total kBtu/h [kW]	74.9 [22.0]	71.8 [21.0]	69.4 [20.3]	69.3 [20.3]	66.3 [19.4]	64.2 [18.8]	63.6 [18.6]	60.9 [17.8]	58.9 [17.3]
		Sens kBtu/h [kW]	44.6 [13.1]	40.0 [11.7]	36.7 [10.8]	53.2 [15.6]	47.8 [14.0]	43.8 [12.8]	61.8 [18.1]	55.5 [16.3]	50.9 [14.9]
		Power	4.3	4.2	4.1	4.2	4.2	4.1	4.2	4.1	4.1
	85°F [29.4°C]	Total kBtu/h [kW]	72.8 [21.3]	69.7 [20.4]	67.5 [19.8]	67.2 [19.7]	64.3 [18.8]	62.2 [18.2]	61.5 [18.0]	58.9 [17.3]	57.0 [16.7]
		Sens kBtu/h [kW]	43.5 [12.7]	39.1 [11.5]	35.8 [10.5]	52.2 [15.3]	46.8 [13.7]	42.9 [12.6]	60.8 [17.8]	54.6 [16.0]	50.0 [14.7]
		Power	4.5	4.4	4.3	4.5	4.4	4.3	4.4	4.4	4.3
	90°F [32.2°C]	Total kBtu/h [kW]	70.7 [20.7]	67.7 [19.8]	65.5 [19.2]	65.1 [19.1]	62.3 [18.3]	60.3 [17.7]	59.4 [17.4]	56.9 [16.7]	55.0 [16.1]
		Sens kBtu/h [kW]	42.5 [12.5]	38.1 [11.2]	34.9 [10.2]	51.1 [15.0]	45.9 [13.5]	42.0 [12.3]	59.4 [17.4]	53.6 [15.7]	49.2 [14.4]
		Power	4.7	4.6	4.5	4.7	4.6	4.5	4.7	4.6	4.5
95°F [35°C]	Total kBtu/h [kW]	68.7 [20.1]	65.7 [19.3]	63.6 [18.6]	63.0 [18.5]	60.3 [17.7]	58.4 [17.1]	57.3 [16.8]	54.9 [16.1]	53.1 [15.6]	
	Sens kBtu/h [kW]	41.4 [12.1]	37.2 [10.9]	34.1 [10.0]	50.1 [14.7]	45.0 [13.2]	41.2 [12.1]	57.3 [16.8]	52.7 [15.4]	48.3 [14.2]	
	Power	5.0	4.9	4.8	5.0	4.9	4.8	4.9	4.8	4.8	
100°F [37.8°C]	Total kBtu/h [kW]	66.6 [19.5]	63.7 [18.7]	61.7 [18.1]	60.9 [17.8]	58.3 [17.1]	56.4 [16.5]	55.2 [16.2]	52.9 [15.5]	51.2 [15.0]	
	Sens kBtu/h [kW]	40.4 [11.8]	36.3 [10.6]	33.2 [9.7]	49.0 [14.4]	44.0 [12.9]	40.3 [11.8]	55.2 [16.2]	51.8 [15.2]	47.4 [13.9]	
	Power	5.3	5.1	5.1	5.2	5.1	5.0	5.2	5.1	5.0	
105°F [40.6°C]	Total kBtu/h [kW]	64.5 [18.9]	61.7 [18.1]	59.7 [17.5]	58.8 [17.2]	56.3 [16.5]	54.5 [16.0]	53.1 [15.6]	50.9 [14.9]	49.2 [14.4]	
	Sens kBtu/h [kW]	39.3 [11.5]	35.3 [10.3]	32.4 [9.5]	48.0 [14.1]	43.1 [12.6]	39.5 [11.6]	53.1 [15.6]	50.8 [14.9]	46.6 [13.7]	
	Power	5.6	5.4	5.4	5.5	5.4	5.3	5.5	5.4	5.3	
110°F [43.3°C]	Total kBtu/h [kW]	62.4 [18.3]	59.7 [17.5]	57.8 [16.9]	56.7 [16.6]	54.3 [15.9]	52.5 [15.4]	51.1 [15]	48.9 [14.3]	47.3 [13.9]	
	Sens kBtu/h [kW]	38.3 [11.2]	34.4 [10.1]	31.5 [9.2]	46.9 [13.7]	42.1 [12.3]	38.6 [11.3]	51.1 [15]	48.9 [14.3]	45.7 [13.4]	
	Power	5.9	5.8	5.7	5.9	5.7	5.7	5.9	5.7	5.6	
115°F [46.1°C]	Total kBtu/h [kW]	60.3 [17.7]	57.7 [16.9]	55.8 [16.4]	54.6 [16.0]	52.3 [15.3]	50.6 [14.8]	49.0 [14.4]	46.9 [13.7]	45.4 [13.3]	
	Sens kBtu/h [kW]	37.3 [10.9]	33.5 [9.8]	30.7 [9.0]	45.9 [13.5]	41.2 [12.1]	37.8 [11.1]	49.0 [14.4]	46.9 [13.7]	44.9 [13.2]	
	Power	6.2	6.1	6.0	6.2	6.1	6.0	6.2	6.1	6.0	
120°F [48.9°C]	Total kBtu/h [kW]	58.2 [17.1]	55.7 [16.3]	53.9 [15.8]	52.5 [15.4]	50.3 [14.7]	48.7 [14.3]	46.9 [13.7]	44.9 [13.2]	43.4 [12.7]	
	Sens kBtu/h [kW]	36.2 [10.6]	32.5 [9.5]	29.8 [8.7]	44.8 [13.1]	40.3 [11.8]	36.9 [10.8]	46.9 [13.7]	44.9 [13.2]	43.4 [12.7]	
	Power	6.6	6.5	6.4	6.6	6.5	6.4	6.6	6.4	6.3	
125°F [51.7°C]	Total kBtu/h [kW]	56.1 [16.4]	53.7 [15.7]	52.0 [15.2]	50.4 [14.8]	48.3 [14.2]	46.7 [13.7]	44.8 [13.1]	42.9 [12.6]	41.5 [12.2]	
	Sens kBtu/h [kW]	35.2 [10.3]	31.6 [9.3]	28.9 [8.5]	43.8 [12.8]	39.3 [11.5]	36.0 [10.6]	44.8 [13.1]	42.9 [12.6]	41.5 [12.2]	
	Power	7.0	6.9	6.8	7.0	6.8	6.7	7.0	6.8	6.7	

DR —Depression ratio  
dbE —Entering air dry bulb  
wbE —Entering air wet bulb  
Power —kW input

NOTES: ① When the entering air dry bulb is other than 80°F [27°C], adjust the sensible capacity from the table by adding [1.10 x CFM x (1 - DR) x (dbE - 80)].

[ ] Designates Metric Conversions

## HEATING PERFORMANCE DATA—RHPCYC036

IDB		60°F [15.6°C]			70°F [21.1°C]			80°F [26.7°C]			
		CFM [L/s]	1450 [684]	1175 [555]	975 [460]	1450 [684]	1175 [555]	975 [460]	1450 [684]	1175 [555]	975 [460]
OUTDOOR DRY BULB TEMPERATURE °F [°C]	0°F [-17.8°C]	Total kBtu/h [kW] Power	4.5 [1.3] 2.7	4.5 [1.3] 2.7	4.4 [1.3] 2.8	3.1 [0.9] 2.9	3.0 [0.9] 3.0	3.0 [0.9] 3.1	1.6 [0.5] 3.2	1.6 [0.5] 3.3	1.6 [0.5] 3.4
	5°F [-15.0°C]	Total kBtu/h [kW] Power	8.1 [2.4] 2.5	8.0 [2.3] 2.6	7.9 [2.3] 2.6	6.7 [2.0] 2.8	6.6 [1.9] 2.8	6.5 [1.9] 2.9	5.2 [1.5] 3.0	5.1 [1.5] 3.1	5.1 [1.5] 3.2
	10°F [-12.2°C]	Total kBtu/h [kW] Power	11.8 [3.5] 2.3	11.6 [3.4] 2.4	11.4 [3.3] 2.5	10.3 [3.0] 2.6	10.1 [3.0] 2.7	10.0 [2.9] 2.8	8.8 [2.6] 2.9	8.7 [2.5] 3.0	8.6 [2.5] 3.1
	15°F [-9.4°C]	Total kBtu/h [kW] Power	15.4 [4.5] 2.2	15.1 [4.4] 2.3	14.9 [4.4] 2.4	13.9 [4.1] 2.5	13.7 [4.0] 2.6	13.5 [4.0] 2.7	12.4 [3.6] 2.8	12.2 [3.6] 2.9	12.1 [3.5] 3.0
	20°F [-6.7°C]	Total kBtu/h [kW] Power	19.0 [5.6] 2.2	18.6 [5.5] 2.2	18.4 [5.4] 2.3	17.5 [5.1] 2.5	17.2 [5.0] 2.5	17.0 [5.0] 2.6	16.0 [4.7] 2.7	15.7 [4.6] 2.8	15.6 [4.6] 2.9
	25°F [-3.9°C]	Total kBtu/h [kW] Power	22.6 [6.6] 2.2	22.2 [6.5] 2.2	21.9 [6.4] 2.3	21.1 [6.2] 2.4	20.7 [6.1] 2.5	20.5 [6.0] 2.6	19.6 [5.7] 2.7	19.3 [5.7] 2.8	19.1 [5.6] 2.9
	30°F [-1.1°C]	Total kBtu/h [kW] Power	26.2 [7.7] 2.2	25.7 [7.5] 2.2	25.4 [7.4] 2.3	24.7 [7.2] 2.5	24.3 [7.1] 2.5	24.0 [7.0] 2.6	23.2 [6.8] 2.7	22.8 [6.7] 2.8	22.6 [6.6] 2.9
	35°F [1.7°C]	Total kBtu/h [kW] Power	29.8 [8.7] 2.2	29.3 [8.6] 2.3	28.9 [8.5] 2.3	28.3 [8.3] 2.5	27.8 [8.1] 2.6	27.5 [8.1] 2.6	26.8 [7.9] 2.8	26.4 [7.7] 2.9	26.1 [7.6] 2.9
	40°F [4.4°C]	Total kBtu/h [kW] Power	33.4 [9.8] 2.3	32.8 [9.6] 2.4	32.4 [9.5] 2.4	31.9 [9.3] 2.6	31.4 [9.2] 2.7	31.0 [9.1] 2.7	30.4 [8.9] 2.9	29.9 [8.8] 3.0	29.6 [8.7] 3.0
	45°F [7.2°C]	Total kBtu/h [kW] Power	37.0 [10.8] 2.4	36.4 [10.7] 2.5	35.9 [10.5] 2.6	35.5 [10.4] 2.7	34.9 [10.2] 2.8	34.5 [10.1] 2.9	34.0 [10.0] 3.0	33.5 [9.8] 3.1	33.1 [9.7] 3.2
	50°F [10.0°C]	Total kBtu/h [kW] Power	40.6 [11.9] 2.6	39.9 [11.7] 2.7	39.4 [11.5] 2.7	39.1 [11.5] 2.9	38.5 [11.3] 3.0	38.0 [11.1] 3.0	37.6 [11.0] 3.2	37.0 [10.8] 3.3	36.6 [10.7] 3.3

IDB—Indoor air dry bulb

## HEATING PERFORMANCE DATA—RHPCYC048

IDB		60°F [15.6°C]			70°F [21.1°C]			80°F [26.7°C]			
		CFM [L/s]	1975 [932]	1575 [743]	1325 [625]	1975 [932]	1575 [743]	1325 [625]	1975 [932]	1575 [743]	1325 [625]
OUTDOOR DRY BULB TEMPERATURE °F [°C]	0°F [-17.8°C]	Total kBtu/h [kW] Power	19.1 [5.6] 2.9	18.8 [5.5] 3.0	18.6 [5.5] 3.0	18 [5.3] 3.3	17.7 [5.2] 3.4	17.5 [5.1] 3.5	16.9 [5.0] 3.7	16.6 [4.9] 3.8	16.4 [4.8] 3.9
	5°F [-15.0°C]	Total kBtu/h [kW] Power	22.6 [6.6] 2.9	22.2 [6.5] 3.0	21.9 [6.4] 3.1	21.4 [6.3] 3.3	21.1 [6.2] 3.4	20.8 [6.1] 3.5	20.3 [5.9] 3.7	19.9 [5.8] 3.8	19.7 [5.8] 3.9
	10°F [-12.2°C]	Total kBtu/h [kW] Power	26.0 [7.6] 2.9	25.6 [7.5] 3.0	25.3 [7.4] 3.1	24.9 [7.3] 3.4	24.4 [7.2] 3.5	24.2 [7.1] 3.5	23.7 [6.9] 3.8	23.3 [6.8] 3.9	23.1 [6.8] 4.0
	15°F [-9.4°C]	Total kBtu/h [kW] Power	29.5 [8.6] 3.0	28.9 [8.5] 3.1	28.6 [8.4] 3.1	28.3 [8.3] 3.4	27.8 [8.1] 3.5	27.5 [8.1] 3.6	27.2 [8.0] 3.8	26.7 [7.8] 3.9	26.4 [7.7] 4.0
	20°F [-6.7°C]	Total kBtu/h [kW] Power	32.9 [9.6] 3.0	32.3 [9.5] 3.1	32.0 [9.4] 3.1	31.8 [9.3] 3.4	31.2 [9.1] 3.5	30.9 [9.1] 3.6	30.6 [9.0] 3.8	30.1 [8.8] 3.9	29.7 [8.7] 4.0
	25°F [-3.9°C]	Total kBtu/h [kW] Power	36.4 [10.7] 3.0	35.7 [10.5] 3.1	35.3 [10.3] 3.2	35.2 [10.3] 3.4	34.6 [10.1] 3.6	34.2 [10.0] 3.6	34.1 [10.0] 3.8	33.5 [9.8] 4.0	33.1 [9.7] 4.0
	30°F [-1.1°C]	Total kBtu/h [kW] Power	39.8 [11.7] 3.0	39.1 [11.5] 3.1	38.6 [11.3] 3.2	38.7 [11.3] 3.5	38.0 [11.1] 3.6	37.5 [11.0] 3.7	37.5 [11.0] 3.9	36.9 [10.8] 4.0	36.4 [10.7] 4.1
	35°F [1.7°C]	Total kBtu/h [kW] Power	43.2 [12.7] 3.1	42.5 [12.5] 3.2	42.0 [12.3] 3.2	42.1 [12.3] 3.5	41.4 [12.1] 3.6	40.9 [12.0] 3.7	41.0 [12.0] 3.9	40.2 [11.8] 4.0	39.8 [11.7] 4.1
	40°F [4.4°C]	Total kBtu/h [kW] Power	46.7 [13.7] 3.1	45.9 [13.5] 3.2	45.3 [13.3] 3.3	45.6 [13.4] 3.5	44.7 [13.1] 3.6	44.2 [13.0] 3.7	44.4 [13.0] 3.9	43.6 [12.8] 4.1	43.1 [12.6] 4.1
	45°F [7.2°C]	Total kBtu/h [kW] Power	50.1 [14.7] 3.1	49.2 [14.4] 3.2	48.7 [14.3] 3.3	49 [14.4] 3.6	48.1 [14.1] 3.7	47.6 [14.0] 3.7	47.9 [14.0] 4.0	47.0 [13.8] 4.1	46.5 [13.6] 4.2
	50°F [10.0°C]	Total kBtu/h [kW] Power	53.6 [15.7] 3.2	52.6 [15.4] 3.3	52.0 [15.2] 3.3	52.4 [15.4] 3.6	51.5 [15.1] 3.7	50.9 [14.9] 3.8	51.3 [15.0] 4.0	50.4 [14.8] 4.1	49.8 [14.6] 4.2

IDB—Indoor air dry bulb

[ ] Designates Metric Conversions

## HEATING PERFORMANCE DATA—RHPCYC060

IDB		60°F [15.6°C]			70°F [21.1°C]			80°F [26.7°C]			
CFM [L/s]		2350 [1109]	1950 [920]	1575 [743]	2350 [1109]	1950 [920]	1575 [743]	2350 [1109]	1950 [920]	1575 [743]	
O U T D O O R  D R Y  B U L B  T E M P E R A T U R E  ° F [ ° C]	0°F [-17.8°C]	Total kBtu/h [kW] Power	24.9 [7.3] 4.1	24.6 [7.2] 4.2	24.2 [7.1] 4.3	23.2 [6.8] 4.5	22.9 [6.7] 4.6	22.6 [6.6] 4.7	21.5 [6.3] 4.8	21.2 [6.2] 5.0	20.9 [6.1] 5.1
	5°F [-15.0°C]	Total kBtu/h [kW] Power	28.8 [8.4] 4.0	28.4 [8.3] 4.1	28.0 [8.2] 4.2	27.1 [7.9] 4.4	26.7 [7.8] 4.5	26.3 [7.7] 4.6	25.4 [7.4] 4.7	25.0 [7.3] 4.8	24.6 [7.2] 5.0
	10°F [-12.2°C]	Total kBtu/h [kW] Power	32.7 [9.6] 3.9	32.2 [9.4] 4.0	31.7 [9.3] 4.1	30.9 [9.1] 4.3	30.5 [8.9] 4.4	30.1 [8.8] 4.5	29.2 [8.6] 4.6	28.8 [8.4] 4.7	28.4 [8.3] 4.9
	15°F [-9.4°C]	Total kBtu/h [kW] Power	36.5 [10.7] 3.8	36.0 [10.6] 3.9	35.5 [10.4] 4.0	34.8 [10.2] 4.2	34.3 [10.1] 4.3	33.8 [9.9] 4.4	33.1 [9.7] 4.5	32.6 [9.6] 4.7	32.1 [9.4] 4.8
	20°F [-6.7°C]	Total kBtu/h [kW] Power	40.4 [11.8] 3.8	39.8 [11.7] 3.9	39.2 [11.5] 4.0	38.7 [11.3] 4.1	38.1 [11.2] 4.2	37.6 [11.0] 4.3	36.9 [10.8] 4.5	36.4 [10.7] 4.6	35.9 [10.5] 4.7
	25°F [-3.9°C]	Total kBtu/h [kW] Power	44.2 [13.0] 3.7	43.6 [12.8] 3.8	43.0 [12.6] 3.9	42.5 [12.5] 4.1	41.9 [12.3] 4.2	41.3 [12.1] 4.3	40.8 [12.0] 4.5	40.2 [11.8] 4.6	39.7 [11.6] 4.7
	30°F [-1.1°C]	Total kBtu/h [kW] Power	48.1 [14.1] 3.7	47.4 [13.9] 3.8	46.7 [13.7] 3.9	46.4 [13.6] 4.1	45.7 [13.4] 4.2	45.1 [13.2] 4.3	44.7 [13.1] 4.5	44.0 [12.9] 4.6	43.4 [12.7] 4.7
	35°F [1.7°C]	Total kBtu/h [kW] Power	52.0 [15.2] 3.8	51.2 [15.0] 3.9	50.5 [14.8] 3.9	50.2 [14.7] 4.1	49.5 [14.5] 4.2	48.8 [14.3] 4.3	48.5 [14.2] 4.5	47.8 [14.0] 4.6	47.2 [13.8] 4.7
	40°F [4.4°C]	Total kBtu/h [kW] Power	55.8 [16.4] 3.8	55.0 [16.1] 3.9	54.3 [15.9] 4.0	54.1 [15.9] 4.2	53.3 [15.6] 4.3	52.6 [15.4] 4.4	52.4 [15.4] 4.5	51.6 [15.1] 4.6	50.9 [14.9] 4.7
	45°F [7.2°C]	Total kBtu/h [kW] Power	59.7 [17.5] 3.9	58.8 [17.2] 4.0	58.0 [17.0] 4.0	58.0 [17.0] 4.2	57.1 [16.7] 4.3	56.3 [16.5] 4.4	56.2 [16.5] 4.6	55.4 [16.2] 4.7	54.7 [16.0] 4.8
	50°F [10.0°C]	Total kBtu/h [kW] Power	63.5 [18.6] 3.9	62.6 [18.3] 4.0	61.8 [18.1] 4.1	61.8 [18.1] 4.3	60.9 [17.8] 4.4	60.1 [17.6] 4.5	60.1 [17.6] 4.7	59.2 [17.4] 4.8	58.4 [17.1] 4.9

IDB—Indoor air dry bulb

[ ] Designates Metric Conversions

# AIRFLOW PERFORMANCE—3.0 TON

Air Flow CFM [L/s]		External Static Pressure—Inches of Water [kPa]																																											
		0.1 [0.02]		0.2 [0.05]		0.3 [0.07]		0.4 [0.10]		0.5 [0.12]		0.6 [0.15]		0.7 [0.17]		0.8 [0.20]		0.9 [0.22]		1.0 [0.25]		1.1 [0.27]		1.2 [0.30]		1.3 [0.32]		1.4 [0.35]		1.5 [0.37]															
		RPM	W	%	RPM	W	%	RPM	W	%	RPM	W	%	RPM	W	%	RPM	W	%	RPM	W	%	RPM	W	%	RPM	W	%	RPM	W	%	RPM	W	%	RPM	W	%								
900 [425]	464	72	20.0	542	95	23.0	609	119	24.5	669	144	26.5	723	168	28.5	779	199	31.0	832	231	33.5	885	265	36.0	925	290	37.5	960	319	39.5	1001	354	41.0	1039	390	43.5	1073	415	45.0	1109	452	46.5	1143	488	48.0
1000 [472]	488	86	23.0	564	112	25.0	633	144	28.0	692	171	30.0	741	194	31.5	790	221	33.5	841	253	35.5	890	286	38.0	937	321	40.0	977	356	42.0	1020	395	44.5	1054	423	46.0	1094	467	48.0	1124	494	49.5	1157	529	51.5
1100 [519]	519	108	25.5	589	136	28.0	659	171	31.0	707	192	33.0	761	225	34.5	809	252	36.5	858	287	39.0	902	315	41.0	945	349	43.0	981	381	45.0	1029	427	47.0	1070	467	49.0	1108	505	51.5	1144	550	53.0	1171	578	55.0
1200 [566]	545	130	28.5	614	160	31.0	677	191	34.0	730	222	36.0	780	255	38.5	827	286	40.0	878	327	42.5	922	360	44.5	962	394	46.5	997	426	48.0	1035	454	50.0	1077	504	52.0	1118	551	54.0	1158	599	56.5	1185	629	58.0
1300 [613]	578	159	32.0	641	189	35.0	702	225	37.5	752	255	39.5	806	297	42.0	850	327	44.0	898	370	46.5	940	404	48.0	979	443	50.5	1008	461	51.5	1050	505	53.0	1088	549	55.5	1128	597	57.5	1160	629	59.0	1194	679	61.0
1400 [661]	605	187	35.5	665	219	38.5	724	257	41.0	779	298	43.5	826	335	46.0	874	377	48.0	914	405	49.5	960	453	52.0	996	491	54.0	1028	519	55.5	1064	552	57.0	1104	601	59.5	1140	646	61.0	1173	682	62.5	1201	715	63.5
1500 [708]	632	217	39.5	696	260	42.0	750	297	45.0	802	339	47.0	849	378	49.5	895	423	52.0	939	466	54.0	976	495	56.0	1013	537	58.0	1046	572	60.0	1078	598	60.5	1122	665	63.5	1152	698	64.5	1189	754	66.5	1217	790	67.0

Air Flow CFM [L/s]		External Static Pressure—Inches of Water [kPa]																																											
		0.1 [0.02]		0.2 [0.05]		0.3 [0.07]		0.4 [0.10]		0.5 [0.12]		0.6 [0.15]		0.7 [0.17]		0.8 [0.20]		0.9 [0.22]		1.0 [0.25]		1.1 [0.27]		1.2 [0.30]		1.3 [0.32]		1.4 [0.35]		1.5 [0.37]															
		RPM	W	%	RPM	W	%	RPM	W	%	RPM	W	%	RPM	W	%	RPM	W	%	RPM	W	%	RPM	W	%	RPM	W	%	RPM	W	%	RPM	W	%	RPM	W	%	RPM	W	%					
900 [425]	458	71	20.0	534	93	22.5	600	117	24.5	660	143	26.5	714	166	28.5	767	196	31.0	813	219	33.0	863	252	34.5	909	285	37.5	944	315	39.5	983	347	41.5	1021	384	41.5	1055	409	45.0	1094	455	47.0	1126	490	49.0
1000 [472]	482	85	23.0	556	111	25.0	616	134	27.5	674	160	29.5	728	187	31.0	777	217	33.5	827	248	35.5	872	274	37.5	918	306	39.5	958	350	42.0	997	380	44.0	1035	416	44.0	1073	458	48.5	1104	485	50.0	1136	520	51.5
1100 [519]	514	107	25.5	581	133	28.0	641	160	30.0	696	188	32.0	740	208	33.5	788	238	36.0	836	270	38.5	884	304	40.5	930	341	43.0	966	375	44.5	1007	413	46.5	1045	446	46.5	1087	494	51.0	1118	524	52.5	1152	568	54.0
1200 [566]	539	128	28.5	606	158	31.0	666	189	33.5	717	218	35.5	766	249	38.0	805	271	39.5	851	303	41.5	899	340	43.5	943	378	46.0	977	406	47.0	1018	448	49.5	1057	484	49.5	1095	527	53.5	1132	573	55.5	1166	618	57.5
1300 [613]	564	151	31.5	632	187	35.0	689	218	36.5	739	249	39.0	785	281	41.5	828	315	43.5	867	339	45.0	914	379	47.5	954	417	49.0	991	452	51.0	1027	481	52.5	1068	527	52.5	1106	573	57.0	1142	619	59.0	1173	652	60.5
1400 [661]	596	184	35.5	654	215	38.0	714	254	41.0	762	287	42.5	804	316	45.0	844	350	46.5	885	381	48.5	930	422	50.5	966	454	52.5	1004	496	54.0	1042	539	56.5	1080	572	56.5	1118	620	60.5	1153	669	62.0	1184	704	63.5
1500 [708]	620	213	39.0	685	257	42.0	739	293	44.5	784	326	46.5	827	358	48.5	866	395	50.5	904	426	52.0	947	469	55.0	985	511	56.5	1022	553	58.5	1055	584	60.5	1094	633	60.5	1128	670	63.5	1165	722	66.0	1194	759	67.0

NOTES: 1. Factory airflow setting of VDC (%) at AHRI minimum External Static Pressure. Adjust VDC (%) value to achieve desired airflow.

2. Do not set outside range of VDC (%) values from the values shown in Table

3. Drive data is for Sideflow/Downflow with dry coil.

4. Pressure drop across wet coil: ~0.09 inches w.c.

[ ] Designates Metric Conversions

# AIRFLOW PERFORMANCE — 3.0 TON

Air Flow CFM (L/s)		External Static Pressure—Inches of Water [kPa]																																											
		0.1 L.02]		0.2 L.05]		0.3 L.07]		0.4 L.010]		0.5 L.12]		0.6 L.15]		0.7 L.17]		0.8 L.20]		0.9 L.22]		1.0 L.25]		1.1 L.27]		1.2 L.30]		1.3 L.32]		1.4 L.35]		1.5 L.37]															
RPM	W %	RPM	W %	RPM	W %	RPM	W %	RPM	W %	RPM	W %	RPM	W %	RPM	W %	RPM	W %	RPM	W %	RPM	W %	RPM	W %	RPM	W %	RPM	W %	RPM	W %																
900 [425]	432	69	19.0	538	101	22.0	611	127	24.0	669	149	26.0	721	170	28.0	773	194	30.0	825	231	32.0	871	260	34.0	911	282	36.0	958	319	38.0	1015	357	40.0	1054	393	42.0	1085	418	44.0	1124	456	46.0	1156	490	47.3
1000 [472]	480	89	22.0	562	118	24.0	623	140	26.0	682	166	28.5	734	189	30.0	788	219	32.2	838	254	34.3	882	279	36.4	925	310	38.0	966	341	40.0	1011	380	42.1	1045	405	44.0	1096	445	46.0	1136	493	48.0	1170	532	50.0
1100 [519]	507	107	24.0	583	138	27.3	649	170	30.0	708	202	32.0	759	229	33.9	803	251	36.0	854	288	38.0	901	320	40.0	945	356	42.0	985	383	44.0	1026	421	46.0	1066	466	48.0	1101	497	49.6	1133	528	51.6	1168	576	54.0
1200 [566]	534	129	28.0	605	160	30.0	669	192	32.0	720	220	34.1	770	247	36.3	825	290	39.7	864	310	40.1	916	355	43.4	959	395	46.0	1004	438	47.7	1041	460	48.2	1079	503	51.3	1118	551	53.8	1147	577	55.5	1180	623	58.0
1300 [613]	552	146	30.0	627	184	32.3	690	221	35.9	744	255	38.0	792	286	40.0	838	317	42.1	881	349	44.0	926	382	46.0	972	429	48.0	1014	468	50.1	1057	510	52.7	1093	551	55.1	1132	600	58.0	1165	642	59.9	1195	675	62.0
1400 [661]	586	180	33.7	650	210	36.0	713	253	38.9	767	291	41.4	814	324	43.9	855	352	46.0	903	401	48.0	947	439	50.0	985	469	52.0	1029	516	54.1	1073	568	57.6	1106	603	59.2	1145	651	61.9	1179	698	64.0	1208	732	66.0
1500 [708]	614	212	37.7	676	249	40.0	735	287	42.3	790	332	45.8	837	371	47.6	879	405	49.9	918	438	51.8	963	486	54.0	1000	514	56.1	1042	559	58.2	1087	617	61.4	1121	665	63.8	1157	705	66.0	1190	750	68.0	1221	795	70.1

Air Flow CFM (L/s)		External Static Pressure—Inches of Water [kPa]																																											
		0.1 L.02]		0.2 L.05]		0.3 L.07]		0.4 L.010]		0.5 L.12]		0.6 L.15]		0.7 L.17]		0.8 L.20]		0.9 L.22]		1.0 L.25]		1.1 L.27]		1.2 L.30]		1.3 L.32]		1.4 L.35]		1.5 L.37]															
RPM	W %	RPM	W %	RPM	W %	RPM	W %	RPM	W %	RPM	W %	RPM	W %	RPM	W %	RPM	W %	RPM	W %	RPM	W %	RPM	W %	RPM	W %	RPM	W %	RPM	W %																
900 [425]	455	71	31.0	549	95	37.0	621	124	43.0	678	147	47.0	731	173	50.7	786	203	55.0	832	229	57.9	863	237	60.5	918	283	64.5	957	307	67.2	976	296	69.7	1030	359	72.5	1066	397	74.9	1090	416	77.0	1130	462	80.2
1000 [472]	480	87	32.5	562	116	38.5	639	147	44.0	700	174	48.7	755	203	52.6	803	226	56.0	850	259	59.3	886	279	62.0	932	314	65.5	975	349	68.4	1000	353	71.1	1049	422	74.0	1080	442	76.2	1109	467	78.5	1146	510	81.1
1100 [519]	502	103	34.0	583	137	39.9	654	168	45.0	712	192	49.5	773	229	63.5	828	264	57.5	872	294	61.0	909	321	63.5	950	350	66.9	993	391	69.6	1024	410	72.5	1060	449	74.6	1094	487	77.5	1128	518	80.0	1162	558	82.0
1200 [566]	530	125	36.2	603	157	41.6	669	190	46.0	729	221	50.5	786	253	55.5	848	302	59.1	890	327	62.2	925	352	65.0	969	392	68.0	1007	424	71.0	1048	467	73.9	1077	495	76.0	1108	527	78.2	1146	571	81.0	1183	618	83.7
1300 [613]	561	152	38.4	624	181	43.1	685	216	47.5	745	254	51.7	803	290	56.0	854	316	60.0	903	357	63.5	950	405	66.8	993	445	69.7	1025	466	72.5	1061	501	75.0	1095	545	77.5	1127	578	80.0	1163	624	82.0	1197	667	84.9
1400 [661]	588	179	40.3	646	209	44.6	700	239	48.7	758	282	52.5	813	316	56.6	872	363	61.0	925	412	65.0	970	463	68.0	1008	486	71.0	1051	537	74.0	1081	559	76.5	1113	598	78.5	1147	643	80.9	1183	694	83.8	1212	726	85.8
1500 [708]	617	211	42.7	675	247	46.5	722	275	50.0	774	312	54.4	829	353	57.7	886	401	62.0	940	459	65.9	975	477	68.5	1025	539	72.5	1059	564	75.0	1101	620	77.7	1128	649	80.0	1167	707	82.3	1197	741	84.8	1232	798	87.2

- NOTES:** 1. Factory airflow setting of VDC (%) at AHRI minimum External Static Pressure. Adjust VDC (%) value to achieve desired airflow.  
 2. Do not set outside range of VDC (%) values from the values shown in Table  
 3. Drive data is for Sideflow/Downflow with dry coil.  
 4. Pressure drop across wet coil: ~0.09 inches w.c.

[ ] Designates Metric Conversions

# AIRFLOW PERFORMANCE — 4.0 TON

Air Flow CFM [L/s]		External Static Pressure—Inches of Water [kPa]																																															
		0.1 [0.02]		0.2 [0.05]		0.3 [0.07]		0.4 [0.10]		0.5 [0.12]		0.6 [0.15]		0.7 [0.17]		0.8 [0.20]		0.9 [0.22]		1.0 [0.25]		1.1 [0.27]		1.2 [0.30]		1.3 [0.32]		1.4 [0.35]		1.5 [0.37]																			
		RPM	W	%	RPM	W	%	RPM	W	%	RPM	W	%	RPM	W	%	RPM	W	%	RPM	W	%	RPM	W	%	RPM	W	%	RPM	W	%	RPM	W	%															
1200	566	550	130	28.5	632	168	31.5	700	206	35.0	754	237	36.5	807	271	39.0	851	298	41.0	887	329	42.5	933	364	44.5	972	398	46.5	1049	471	50.5	1086	508	52.0	1128	555	54.5	1128	555	54.5	1155	585	55.5	1193	634	57.5			
1300	613	582	160	32.0	657	195	34.5	722	236	38.5	775	268	40.5	826	304	42.0	874	341	44.5	905	365	46.0	955	409	48.5	995	449	50.5	1066	524	54.5	1101	554	56.0	1140	602	58.0	1140	602	58.0	1168	636	59.5	1205	683	61.0			
1400	661	609	187	35.5	685	232	39.0	750	278	42.0	797	308	44.0	849	348	46.5	895	385	48.5	933	422	50.5	977	458	52.5	1013	498	54.0	1082	571	58.0	1121	619	60.5	1157	663	61.5	1157	663	61.5	1184	696	63.0	1224	755	65.0			
1500	708	635	218	39.5	709	268	42.5	770	313	46.0	823	355	48.0	872	396	50.5	916	431	52.5	955	471	54.0	1001	517	56.5	1036	560	58.5	1104	638	62.0	1145	692	64.0	1175	726	66.0	1175	726	66.0	1199	758	67.0	1241	828	69.0			
1600	755	666	258	43.5	732	305	46.5	794	355	49.5	845	400	52.0	894	443	54.0	939	487	57.0	976	528	58.5	1022	577	61.0	1054	618	63.0	1126	709	67.0	1163	755	68.5	1195	805	70.0	1222	848	72.0	1259	909	72.5						
1700	802	704	308	48.0	760	352	51.0	815	398	53.5	868	452	56.5	917	498	58.5	961	544	61.0	995	583	63.0	1039	635	65.0	1072	673	67.0	1144	778	71.0	1186	840	73.0	1218	893	74.5	1218	893	74.5	1240	929	75.5	1281	1014	80.0			
1800	849	729	350	52.5	787	404	55.5	837	448	58.0	891	507	61.0	940	557	63.5	982	606	66.0	1017	652	67.5	1059	703	69.5	1091	749	72.0	1166	861	75.0	1211	942	77.5	1240	993	79.5	1240	993	79.5									

Air Flow CFM [L/s]		External Static Pressure—Inches of Water [kPa]																																																	
		0.1 [0.02]		0.2 [0.05]		0.3 [0.07]		0.4 [0.10]		0.5 [0.12]		0.6 [0.15]		0.7 [0.17]		0.8 [0.20]		0.9 [0.22]		1.0 [0.25]		1.1 [0.27]		1.2 [0.30]		1.3 [0.32]		1.4 [0.35]		1.5 [0.37]																					
		RPM	W	%	RPM	W	%	RPM	W	%	RPM	W	%	RPM	W	%	RPM	W	%	RPM	W	%	RPM	W	%	RPM	W	%	RPM	W	%	RPM	W	%	RPM	W	%	RPM	W	%	RPM	W	%	RPM	W	%					
1200	566	541	128	28.5	619	165	31.5	677	193	33.5	734	224	36.0	785	256	38.5	830	287	40.0	873	321	42.0	916	351	44.0	959	382	46.5	994	425	48.0	1036	467	50.5	1074	502	62.0	1103	531	53.5	1142	577	56.0	1179	624	58.0					
1300	613	567	151	31.5	641	191	34.5	702	224	37.5	754	254	39.5	802	287	41.5	851	327	44.0	893	360	45.5	940	403	48.0	980	442	50.5	1011	473	52.0	1047	503	53.5	1085	547	56.0	1117	590	57.5	1151	629	60.0	1188	673	61.0					
1400	661	600	185	35.5	663	218	38.5	723	256	41.0	778	296	43.5	828	334	46.0	876	376	48.0	911	402	49.5	959	450	52.5	999	492	54.0	1027	518	55.5	1068	563	57.5	1100	604	60.0	1129	638	61.0	1165	684	63.0	1201	739	65.0					
1500	708	624	213	39.0	690	257	42.0	747	295	44.5	800	337	47.0	848	377	49.5	894	421	52.0	930	449	53.5	975	493	56.0	1020	551	58.5	1047	579	60.5	1085	622	61.5	1116	660	63.5	1146	703	65.0	1177	743	67.0	1212	789	68.5					
1600	755	651	247	43.0	713	293	45.5	769	334	48.5	822	379	51.5	868	422	53.5	912	462	56.0	951	504	58.0	996	551	60.5	1033	597	62.5	1068	644	64.0	1107	697	67.0	1137	737	68.5	1165	778	69.5	1198	824	71.5	1232	880	72.5					
1700	802	682	291	47.0	741	341	50.5	789	376	52.5	845	431	56.0	891	474	58.0	939	532	61.0	972	562	62.0	1015	612	64.5	1051	661	66.5	1084	701	68.5	1125	765	71.0	1159	819	73.0	1184	853	73.5	1218	907	75.5	1254	981	78.0					
1800	849	716	344	52.5	765	384	54.5	813	425	57.0	866	483	60.5	913	531	62.5	957	586	65.0	993	625	66.5	1038	688	69.5	1068	723	71.0	1104	776	73.0	1145	845	75.0	1174	890	76.5	1204	941	78.5	1239	1007	83.0								

NOTES: 1. Factory airflow setting of VDC (%) at AHRI minimum External Static Pressure. Adjust VDC (%) value to achieve desired airflow.

2. Do not set outside range of VDC (%) values from the values shown in Table

3. Drive data is for Sideflow/Downflow with dry coil.

4. Pressure drop across wet coil: ~0.09 inches w.c.

[ ] Designates Metric Conversions

# AIRFLOW PERFORMANCE—4.0 TON

Air Flow CFM (L/s)		External Static Pressure—Inches of Water [kPa]																																																		
		0.1 [0.02]		0.2 [0.05]		0.3 [0.07]		0.4 [0.10]		0.5 [0.12]		0.6 [0.15]		0.7 [0.17]		0.8 [0.20]		0.9 [0.22]		1.0 [0.25]		1.1 [0.27]		1.2 [0.30]		1.3 [0.32]		1.4 [0.35]		1.5 [0.37]																						
		RPM	W	%	RPM	W	%	RPM	W	%	RPM	W	%	RPM	W	%	RPM	W	%	RPM	W	%	RPM	W	%	RPM	W	%	RPM	W	%																					
1200	566	534	129	28.0	605	160	30.0	669	192	32.0	720	220	34.1	770	247	36.3	825	290	39.7	864	310	40.1	916	355	43.4	959	395	46.0	1004	438	47.7	1041	460	48.2	1079	503	51.3	1118	551	53.8	1147	577	55.5	1180	623	58.0						
1300	613	552	146	30.0	627	184	32.3	690	221	35.9	744	255	38.0	792	286	40.0	838	317	42.1	881	349	44.0	926	382	46.0	972	429	48.0	1014	468	50.1	1057	510	52.7	1093	551	55.1	1132	600	58.0	1165	642	59.9	1195	675	62.0						
1400	661	586	180	33.7	650	210	36.0	713	253	38.9	767	291	41.4	814	324	43.9	855	352	46.0	903	401	48.0	947	439	50.0	985	469	52.0	1029	516	54.1	1073	568	57.6	1106	603	59.2	1145	651	61.9	1179	698	64.0	1208	732	66.0						
1500	708	614	212	37.7	676	249	40.0	735	287	42.3	790	332	45.8	837	371	47.6	879	405	49.9	918	438	51.8	963	486	54.0	1000	514	56.1	1042	559	58.2	1087	617	61.4	1121	665	63.8	1157	705	66.0	1190	750	68.0	1221	795	70.1						
1600	755	636	241	40.7	698	283	43.9	756	320	46.0	809	368	48.3	857	412	51.6	900	453	54.2	936	484	56.0	979	528	58.1	1020	579	61.0	1065	638	64.0	1101	677	66.0	1133	718	68.0	1171	768	70.3	1201	807	72.3	1234	854	74.1						
1700	802	667	284	45.7	727	332	48.0	781	372	50.2	837	428	53.8	877	457	55.9	919	501	58.8	959	544	60.5	1001	557	63.4	1039	640	65.9	1080	690	68.1	1117	740	70.4	1147	779	72.5	1184	829	74.3	1216	879	76.1	1250	944	79.2						
1800	849	695	325	48.9	747	367	51.9	800	417	54.6	856	469	58.0	901	517	60.7	943	565	64.0	980	606	65.8	1022	656	68.0	1060	708	70.8	1104	775	73.9	1134	812	75.0	1165	856	76.5	1202	920	79.7	1233	973	82.9									

Air Flow CFM (L/s)		External Static Pressure—Inches of Water [kPa]																																																	
		0.1 [0.02]		0.2 [0.05]		0.3 [0.07]		0.4 [0.10]		0.5 [0.12]		0.6 [0.15]		0.7 [0.17]		0.8 [0.20]		0.9 [0.22]		1.0 [0.25]		1.1 [0.27]		1.2 [0.30]		1.3 [0.32]		1.4 [0.35]		1.5 [0.37]																					
		RPM	W	%	RPM	W	%	RPM	W	%	RPM	W	%	RPM	W	%	RPM	W	%	RPM	W	%	RPM	W	%	RPM	W	%	RPM	W	%																				
1200	566	530	125	36.2	603	157	41.6	669	190	46.0	729	221	50.5	786	253	55.5	848	302	59.1	890	327	62.2	925	352	65.0	969	392	68.0	1007	424	71.0	1048	467	73.9	1077	495	76.0	1108	527	78.2	1146	571	81.0	1183	618	83.7					
1300	613	561	152	38.4	624	181	43.1	685	216	47.5	745	254	51.7	803	290	56.0	854	316	60.0	903	357	63.5	950	405	66.8	993	445	69.7	1025	466	72.5	1061	501	75.0	1095	545	77.5	1127	578	80.0	1163	624	82.0	1197	667	84.9					
1400	661	588	179	40.3	646	209	44.6	700	239	48.7	758	282	52.5	813	316	56.6	872	363	61.0	925	412	65.0	970	463	68.0	1008	486	71.0	1051	537	74.0	1081	559	76.5	1113	598	78.5	1147	643	80.9	1183	694	83.8	1212	726	85.8					
1500	708	617	211	42.7	675	247	46.5	722	275	50.0	774	312	54.4	829	353	57.7	886	401	62.0	940	459	65.9	975	477	68.5	1025	539	72.5	1059	564	75.0	1101	620	77.7	1128	649	80.0	1167	707	82.3	1197	741	84.8	1232	798	87.2					
1600	755	646	246	44.5	701	284	48.8	745	314	52.2	793	348	55.6	847	399	58.9	902	447	63.0	948	490	66.5	992	538	69.9	1043	604	73.6	1081	637	76.5	1122	696	79.1	1148	723	81.4	1186	781	84.0	1220	838	86.5	1252	882	88.8					
1700	802	677	289	46.7	728	328	50.5	773	365	54.0	817	400	56.9	871	454	61.0	918	496	64.5	969	563	68.0	1009	598	70.9	1055	655	74.5	1097	705	77.5	1132	739	80.0	1167	801	82.4	1199	837	85.0	1235	899	87.5								
1800	849	702	326	48.8	757	377	52.5	790	397	55.5	838	446	58.2	887	498	62.0	933	544	65.6	980	601	69.0	1021	648	72.3	1067	704	75.2	1109	761	78.3	1150	824	81.3	1185	887	83.9	1221	942	86.4	1254	992	89.3								

- NOTES:** 1. Factory airflow setting of VDC (%) at AHRI minimum External Static Pressure. Adjust VDC (%) value to achieve desired airflow.  
 2. Do not set outside range of VDC (%) values from the values shown in Table  
 3. Drive data is for Sideflow/Downflow with dry coil.  
 4. Pressure drop across wet coil: ~0.09 inches w.c.

[ ] Designates Metric Conversions



# AIRFLOW PERFORMANCE—5.0 TON

Air Flow		Model RHPCYC060 Voltage 460 — 3 phase 60 Hz																																															
		External Static Pressure—Inches of Water [kPa]																																															
		0.1 [0.2]	0.2 [0.05]	0.3 [0.07]	0.4 [0.10]	0.5 [0.12]	0.6 [0.15]	0.7 [0.17]	0.8 [0.20]	0.9 [0.22]	1.0 [0.25]	1.1 [0.27]	1.2 [0.30]	1.3 [0.32]	1.4 [0.35]	1.5 [0.37]																																	
RPM	W	%	RPM	W	%	RPM	W	%	RPM	W	%	RPM	W	%	RPM	W	%	RPM	W	%	RPM	W	%	RPM	W	%	RPM	W	%																				
1600 [755]	636	241	40.7	698	283	43.9	756	320	46.0	809	368	48.3	857	412	51.6	900	453	54.2	936	484	56.0	979	528	58.1	1020	579	61.0	1065	638	64.0	1101	677	66.0	1133	718	68.0	1171	768	70.3	1201	807	72.3	1234	854	74.1				
1700 [802]	667	284	45.7	727	332	48.0	781	372	50.2	837	428	53.8	877	457	55.9	919	501	58.8	959	544	60.5	1001	597	63.4	1039	640	65.9	1080	690	68.1	1117	740	70.4	1147	779	72.5	1184	829	74.3	1216	879	76.1	1250	944	79.2				
1800 [849]	695	325	48.9	747	367	51.9	800	417	54.6	856	469	58.0	901	517	60.7	943	565	64.0	990	606	65.8	1022	656	68.0	1060	708	70.8	1104	775	73.9	1134	812	75.0	1165	856	76.5	1202	920	79.7	1233	973	82.9	1255	976	85.1				
1900 [897]	727	377	54.2	772	416	56.6	825	471	59.8	870	512	62.1	922	575	65.8	963	623	68.8	1001	672	70.7	1044	735	73.8	1082	789	75.6	1124	851	78.0	1154	892	79.9	1183	939	82.0	1212	957	85.8	1241	1002	87.2	1266	1043	88.3				
2000 [944]	755	430	59.4	800	474	61.8	846	524	64.3	892	579	67.7	942	638	70.7	985	693	74.0	1026	756	75.8	1064	808	77.9	1099	857	80.1	1146	941	83.6	1176	994	92.8	1193	969	87.4	1225	1020	88.9	1263	1075	91.1	1255	1141	93.6				
2100 [991]	786	490	64.8	829	540	67.4	873	592	70.0	909	630	72.2	956	693	74.6	1005	763	78.3	1044	823	80.4	1085	893	83.4	1125	962	89.1	1136	935	87.7	1172	989	89.3	1207	1042	91.4	1230	1106	93.8	1234	1158	95.2	1251	1227	98.5				
2200 [1038]	816	559	70.7	854	600	72.5	894	654	74.5	936	711	76.7	977	771	79.8	1022	845	84.0	1068	917	87.0	1098	908	88.0	1116	971	90.2	1138	1010	91.9	1137	1070	94.0	1166	1140	96.0	1154	1191	99.0										
2300 [1085]	846	637	75.9	887	669	77.8	923	739	80.2	959	789	82.4	999	858	85.6	1036	918	95.4	1084	935	90.5	1121	1006	93.4	1095	1052	94.8	1058	1118	97.5																			
2400 [1133]	875	714	81.7	914	777	83.9	950	829	86.6	985	885	95.2	1024	885	90.3	1063	945	92.8	1103	1013	94.8	1112	1033	98.8																									

Air Flow		Model RHPCYC060 Voltage 460 — 3 phase 60 Hz																																																
		External Static Pressure—Inches of Water [kPa]																																																
		0.1 [0.02]	0.2 [0.05]	0.3 [0.07]	0.4 [0.10]	0.5 [0.12]	0.6 [0.15]	0.7 [0.17]	0.8 [0.20]	0.9 [0.22]	1.0 [0.25]	1.1 [0.27]	1.2 [0.30]	1.3 [0.32]	1.4 [0.35]	1.5 [0.37]																																		
RPM	W	%	RPM	W	%	RPM	W	%	RPM	W	%	RPM	W	%	RPM	W	%	RPM	W	%	RPM	W	%	RPM	W	%	RPM	W	%																					
1600 [755]	646	246	44.5	701	284	48.8	745	314	52.2	793	348	55.6	847	399	58.9	902	447	63.0	948	490	66.5	992	538	69.9	1043	604	73.6	1081	637	76.5	1122	696	79.1	1148	723	81.4	1186	781	84.0	1220	838	86.5	1252	882	88.8					
1700 [802]	677	289	46.7	728	328	50.5	773	365	54.0	817	400	56.9	871	454	61.0	918	496	64.5	969	563	68.0	1009	598	70.9	1055	655	74.5	1097	705	77.5	1132	739	80.0	1167	801	82.4	1199	837	85.0	1235	899	87.5	1241	915	81.9					
1800 [849]	702	326	48.8	757	377	52.5	790	397	55.5	838	446	58.2	887	498	62.0	933	544	65.6	990	601	69.0	1021	648	72.3	1067	704	75.2	1109	761	78.3	1150	824	81.3	1185	887	83.9	1221	942	86.4	1254	992	89.3	1255	989	86.0					
1900 [897]	736	384	51.0	782	425	54.4	819	457	57.1	860	499	60.3	906	551	63.3	953	605	67.0	996	657	70.5	1032	689	72.7	1080	768	76.5	1123	832	79.4	1161	885	82.2	1196	950	84.9	1233	1015	88.6	1139	1011	88.0	955	1073	90.0					
2000 [944]	764	436	53.1	811	484	56.5	846	518	58.8	886	564	62.0	928	612	65.2	972	667	68.5	1016	728	71.4	1052	777	74.0	1096	844	77.4	1135	896	80.0	1173	951	83.0	1202	976	88.0	936	1041	90.1	1200	1087	92.2	1019	1143	94.0					
2100 [991]	795	498	55.5	837	544	58.5	872	583	61.0	909	626	63.6	950	679	66.9	995	741	70.3	1033	803	73.0	1067	844	75.1	1109	908	78.3	1152	994	86.2	1204	1004	90.1	1198	1047	92.1	941	1110	94.2	856	1192	97.5								
2200 [1038]	828	572	57.5	872	631	61.0	899	655	62.7	933	697	65.5	975	758	68.5	1019	826	71.7	1055	883	74.4	1093	955	87.6	1098	972	90.4	1157	1020	92.3	1154	1081	94.3	860	1156	97.8														
2300 [1085]	857	645	60.0	898	703	62.8	926	736	65.0	969	812	68.0	998	834	70.4	1030	853	87.9	1073	925	90.3	1085	981	92.6	1129	1058	95.1	1162	1128	98.8																				
2400 [1133]	883	692	62.3	929	756	64.0	955	786	66.1	972	809	67.9	1010	871	70.0	1046	918	91.9	1088	991	94.1	1118	1076	98.4																										

- NOTES:** 1. Factory airflow setting of VDC (%) at AHRI minimum External Static Pressure. Adjust VDC (%) value to achieve desired airflow.  
2. Do not set outside range of VDC (%) values from the values shown in Table  
3. Drive data is for Sideflow/Downflow with dry coil. Pressure drop across wet coil: ~0.09 inches w.c.  
4. Grayed highlighted data for L drive

[ ] Designates Metric Conversions

### ELECTRICAL DATA – RHPCYC SERIES

		036ACK	036ADK	036AJK	048ACK	048ADK	048AJK
<b>Unit Information</b>	Unit Operating Voltage Range	187-253	414-506	187-253	187-253	414-506	187-253
	Volts	208/230	460	208/230	208/230	460	208/230
	Phase	3	3	1	3	3	1
	Hz	60	60	60	60	60	60
	Minimum Circuit Ampacity	23	13	30	26	15	34
	Minimum Circuit Ampacity with Powered Exhaust	26	15	33	29	17	37
	Minimum Overcurrent Protection Device Size	30	15	40	35	20	50
	Minimum Overcurrent Protection Device Size with Powered Exhaust	35	15	45	40	20	50
	Maximum Overcurrent Protection Device Size	30	15	40	35	20	50
Maximum Overcurrent Protection Device Size with Powered Exhaust	35	15	45	40	20	50	
<b>Compressor Motor</b>	No.	1	1	1	1	1	1
	Volts	208/230	460	208/230	208/230	460	208/230
	Phase	3	3	1	3	3	1
	Amps (RLA), Comp. 1	9.4	5	14.9	11.9	6.8	18.3
	Amps (LRA), Comp. 1	82	44.3	90	112	61.8	138
<b>Condenser Motor</b>	No.	1	1	1	1	1	1
	Volts	208/230	460	208/230	208/230	460	208/230
	Phase	1	1	1	1	1	1
	HP	0.5	0.5	0.5	0.5	0.5	0.5
	Amps (FLA, each)	3.8	2.3	3.8	3.8	2.3	3.8
<b>Evaporator Fan</b>	No.	1	1	1	1	1	1
	Volts	208/230	460	208/230	208/230	460	208/230
	Phase	1	1	1	1	1	1
	HP	1	1	1	1	1	1
	Amps (FLA, each)	7	3.7	7	7	3.7	7

<b>ELECTRICAL DATA – RHPCYC SERIES</b>							
		<b>060ACK</b>	<b>060ACL</b>	<b>060ADK</b>	<b>060ADL</b>	<b>060AJK</b>	<b>060AJL</b>
<b>Unit Information</b>	Unit Operating Voltage Range	187-253	187-253	414-506	414-506	187-253	187-253
	Volts	208/230	208/230	460	460	208/230	208/230
	Phase	3	3	3	3	1	1
	Hz	60	60	60	60	60	60
	Minimum Circuit Ampacity	29	32	14	16	40	42
	Minimum Circuit Ampacity with Powered Exhaust	32	35	16	18	43	46
	Minimum Overcurrent Protection Device Size	40	45	20	20	60	60
	Minimum Overcurrent Protection Device Size with Powered Exhaust	45	45	20	20	60	60
	Maximum Overcurrent Protection Device Size	40	45	20	20	60	60
Maximum Overcurrent Protection Device Size with Powered Exhaust	45	45	20	20	60	60	
<b>Compressor Motor</b>	No.	1	1	1	1	1	1
	Volts	208/230	208/230	460	460	208/230	208/230
	Phase	3	3	3	3	1	1
	Amps (RLA), Comp. 1	14	14	6.3	6.3	22.3	22.3
	Amps (LRA), Comp. 1	150	150	58	58	149	149
<b>Condenser Motor</b>	No.	1	1	1	1	1	1
	Volts	208/230	208/230	460	460	208/230	208/230
	Phase	1	1	1	1	1	1
	HP	0.5	0.5	0.5	0.5	0.5	0.5
	Amps (FLA, each)	3.8	3.8	2.3	2.3	3.8	3.8
<b>Evaporator Fan</b>	No.	1	1	1	1	1	1
	Volts	208/230	208/230	460	460	208/230	208/230
	Phase	1	1	1	1	1	1
	HP	1	1.5	1	1.5	1	1.5
	Amps (FLA, each)	7.4	10.3	3.7	5	7.4	10.3

**208/230V THREE PHASE, 60 Hz, AUXILIARY ELECTRIC HEATER KIT CHARACTERISTICS AND APPLICATION**

**Separate Power Supply For Both Unit and Heater Kit**

**Single Power Supply For Both Unit and Heater Kit**

Unit Model No. RHPCYC	Heater Kit			Air Conditioner			Heater Kit			Air Conditioner		
	Model No. RXJJ-	Rated Heater kW @ 208/230V	FLA	Unit Min. Ckt. Ampacity	Unit Min. Ckt. Ampacity With Optional Powered Exhaust	Max. Fuse or Ckt. Bkr. Size	Heater Kit Min. Ckt. Ampacity	Heater Kit Max. Fuse or Ckt. Bkr. Size	Air Cond. Min. Ckt. Ampacity With Optional Powered Exhaust	Air Cond. Min. Ckt. Ampacity With Optional Powered Exhaust	Air Cond. Max. Fuse or Ckt. Bkr. Size	Air Cond. Max. Fuse or Ckt. Bkr. Size with Optional Powered Exhaust
036ACK	NONE*	—	—	23/23	26/26	30/30	—	—	23/23	26/26	30/30	35/35
	DC10CP	7.5/10.0	20.9/24.1	49/53	52/56	50/60	27/31	30/35	23/23	26/26	30/30	35/35
	DC15CP	11.3/15.0	31.4/36.2	62/68	65/71	70/70	40/46	40/50	23/23	26/26	30/30	35/35
048ACK	DC20CP	15.0/20.0	41.7/48.1	75/83	78/86	80/90	53/61	60/70	23/23	26/26	30/30	35/35
	NONE*	—	—	26/26	29/29	35/35	—	—	26/26	29/29	35/35	40/40
	DC10CP	7.5/10.0	20.9/24.1	52/56	55/59	60/60	27/31	30/35	26/26	29/29	35/35	40/40
060ACK	DC15CP	11.3/15.0	31.4/36.2	65/71	69/75	70/80	40/46	40/50	26/26	29/29	35/35	40/40
	DC20CP	15.0/20.0	41.7/48.1	78/86	81/89	80/90	53/61	60/70	26/26	29/29	35/35	40/40
	NONE*	—	—	29/29	32/32	40/40	—	—	29/29	32/32	40/40	45/45
060ACL	DC10CP	7.5/10.0	20.9/24.1	55/59	58/62	60/60	27/31	30/35	29/29	32/32	40/40	45/45
	DC15CP	11.3/15.0	31.4/36.2	68/74	72/78	70/80	40/46	40/50	29/29	32/32	40/40	45/45
	DC20CP	15.0/20.0	41.7/48.1	81/89	84/92	90/90	53/61	60/70	29/29	32/32	40/40	45/45
060ACL	NONE*	—	—	32/32	35/35	45/45	—	—	32/32	35/35	45/45	45/45
	DC10CP	7.5/10.0	20.9/24.1	58/62	61/65	60/70	27/31	30/35	32/32	35/35	45/45	45/45
	DC15CP	11.3/15.0	31.4/36.2	71/77	74/80	80/80	40/46	40/50	32/32	35/35	45/45	45/45
DC20CP	15.0/20.0	41.7/48.1	84/92	87/95	90/100	53/61	60/70	32/32	35/35	45/45	45/45	

**460V THREE PHASE, 60 HZ, AUXILIARY ELECTRIC HEATER KIT CHARACTERISTICS AND APPLICATION**

**Separate Power Supply For Both Unit and Heater Kit**

**Single Power Supply For Both Unit and Heater Kit**

Unit Model No. RHPCYC	Heater Kit			Air Conditioner			Heater Kit			Air Conditioner		
	Model No. RXJJ-	Rated Heater kW @ 460V	FLA	Unit Min. Ckt. Ampacity	Unit Min. Ckt. Ampacity With Optional Powered Exhaust	Max. Fuse or Ckt. Bkr. Size	Heater Kit Min. Ckt. Ampacity	Heater Kit Max. Fuse or Ckt. Bkr. Size	Air Cond. Min. Ckt. Ampacity With Optional Powered Exhaust	Air Cond. Max. Fuse or Ckt. Bkr. Size	Air Cond. Min. Ckt. Ampacity	Air Cond. Max. Fuse or Ckt. Bkr. Size
036ADK	NONE*	—	—	13	15	15/15	—	—	13	15	15/15	15/15
	DC10NV	10.0	12.0	28	30	30/30	15	15	13	15	15/15	15/15
	DC15NV	15.0	18.1	35	37	35/35	23	25	13	15	15/15	15/15
	DC20NV	20.0	24.1	43	45	45/45	31	35	13	15	15/15	15/15
048ADK	NONE*	—	—	15	17	20/20	—	—	15	17	20/20	20/20
	DC10NV	10.0	12.0	30	32	30/30	15	15	15	17	20/20	20/20
	DC15NV	15.0	18.1	38	40	40/40	23	25	15	17	20/20	20/20
	DC20NV	20.0	24.1	45	47	45/45	31	35	15	17	20/20	20/20
060ADK	NONE*	—	—	14	16	20/20	—	—	14	16	20/20	20/20
	DC10NV	10.0	12.0	29	31	30/30	15	15	14	16	20/20	20/20
	DC15NV	15.0	18.1	37	39	40/40	23	25	14	16	20/20	20/20
	DC20NV	20.0	24.1	45	47	45/45	31	35	14	16	20/20	20/20
060ADL	NONE*	—	—	16	18	20/20	—	—	16	18	20/20	20/20
	DC10NV	10	12	31	33	35/35	15	15	16	18	20/20	20/20
	DC15NV	15	18.1	38	40	40/40	23	25	16	18	20/20	20/20
	DC20NV	20	24.1	46	48	50/50	31	35	16	18	20/20	20/20

208/230V SINGLE PHASE, 60 Hz, AUXILIARY ELECTRIC HEATER KIT CHARACTERISTICS AND APPLICATION													
Separate Power Supply For Both Unit and Heater Kit													
Single Power Supply For Both Unit and Heater Kit													
Unit Model No. RHPCYC	Heater Kit			Air Conditioner				Heater Kit			Air Conditioner		
	Model No. RXJJ-	Rated Heater kW @ 208/230V	FLA	Unit Min. Ckt. Ampacity	Unit Min. Ckt. Ampacity With Optional Powered Exhaust	Max. Fuse or Ckt. Bkr. Size	Max. Fuse or Ckt. Bkr. Size With Optional Powered Exhaust	Heater Kit Min. Ckt. Ampacity	Heater Kit Max. Fuse or Ckt. Bkr. Size	Air Cond. Min. Ckt. Ampacity	Air Cond. Min. Ckt. Ampacity With Optional Powered Exhaust	Air Cond. Max. Fuse or Ckt. Bkr. Size	Air Cond. Max. Fuse or Ckt. Bkr. Size with Optional Powered Exhaust
036AJK	NONE*	—	—	30/30	33/33	40/40	45/45	—	—	30/30	33/33	40/40	45/45
	DC10NV	7.5/10.0	36.2/41.7	75/82	78/85	80/90	80/90	46/53	50/60	30/30	33/33	40/40	45/45
	DC15NV	11.3/15.0	54.3/62.7	98/108	101/111	100/110	100/125	68/79	70/80	30/30	33/33	40/40	45/45
	DC20NV	15.0/20.0	72.2/83.3	120/134	123/137	125/150	125/150	91/105	100/110	30/30	33/33	40/40	45/45
048AJK	NONE*	—	—	34/34	37/37	50/50	50/50	—	—	34/34	37/37	50/50	50/50
	DC10NV	7.5/10.0	36.2/41.7	79/86	83/89	80/90	90/90	46/53	50/60	34/34	37/37	50/50	50/50
	DC15NV	11.3/15.0	54.3/62.7	102/113	105/116	110/125	110/125	68/79	70/80	34/34	37/37	50/50	50/50
	DC20NV	15.0/20.0	72.2/83.3	124/138	128/141	125/150	150/150	91/105	100/110	34/34	37/37	50/50	50/50
060AJK	NONE*	—	—	40/40	43/43	60/60	60/60	—	—	40/40	43/43	60/60	60/60
	DC10NV	7.5/10.0	36.2/41.7	85/92	88/95	90/100	100/100	46/53	50/60	40/40	43/43	60/60	60/60
	DC15NV	11.3/15.0	54.3/62.7	107/118	111/121	110/125	125/125	68/79	70/80	40/40	43/43	60/60	60/60
	DC20NV	15.0/20.0	72.2/83.3	130/144	133/147	150/150	150/150	91/105	100/110	40/40	43/43	60/60	60/60
060AJL	NONE*	—	—	42/42	46/46	60/60	60/60	—	—	42/42	46/46	60/60	60/60
	DC10NV	7.5/10.0	36.2/41.7	88/95	91/98	100/100	100/100	46/53	50/60	42/42	46/46	60/60	60/60
	DC15NV	11.3/15.0	54.3/62.7	110/121	113/124	110/125	125/125	68/79	70/80	42/42	46/46	60/60	60/60
	DC20NV	15.0/20.0	72.2/83.3	133/147	136/150	150/150	150/150	91/105	100/110	42/42	46/46	60/60	60/60

## A2L REFRIGERANT INSTALLATION SAFETY DATA

		RHPCYC036	RHPCYC048	RHPCYC060
Refrigerant Charge Weight (oz)		155	155	154.5
Minimum Circulation Airflow, Qmin (CFM)		516	516	514
Altitude Above Sea Level (Ft.)	Altitude Adjustment Factor	Minimum Total Conditioned Room Area, T <sub>Amin</sub> (Sq. Ft.)		
0	1.000	286	286	285
1000	1.025	293	293	292
2000	1.051	300	300	299
3000	1.078	308	308	307
4000	1.107	316	316	315
5000	1.138	325	325	324
6000	1.170	334	334	333
6500	1.187	339	339	338

# UNIT DIMENSIONS

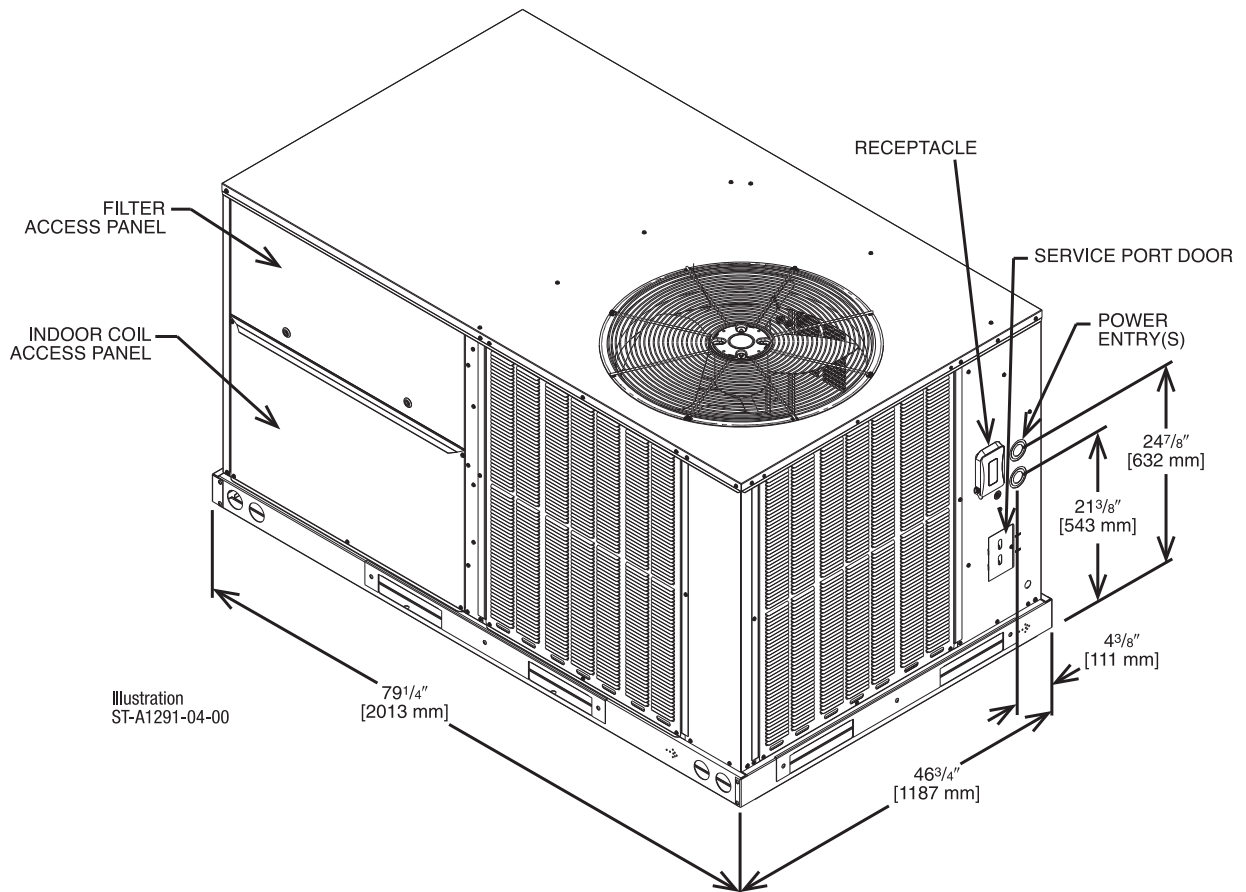
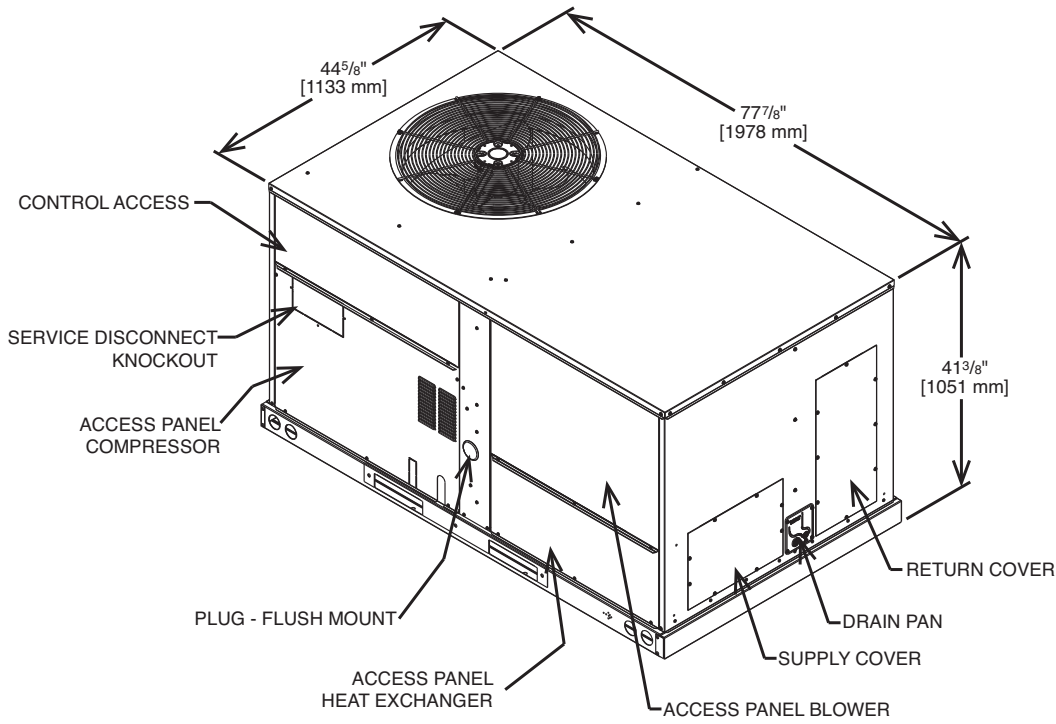

[ ] Designates Metric Conversions

## SUPPLY AND RETURN DIMENSIONS FOR HORIZONTAL APPLICATIONS (SIDE VIEW)

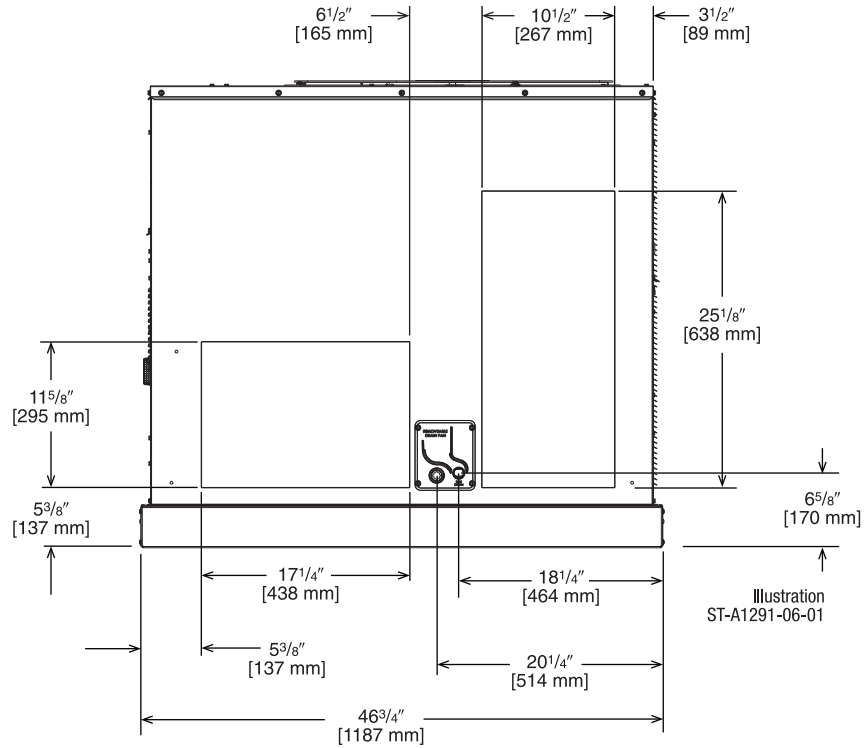

## SUPPLY AND RETURN DIMENSIONS FOR DOWNFLOW APPLICATIONS (BOTTOM VIEW)

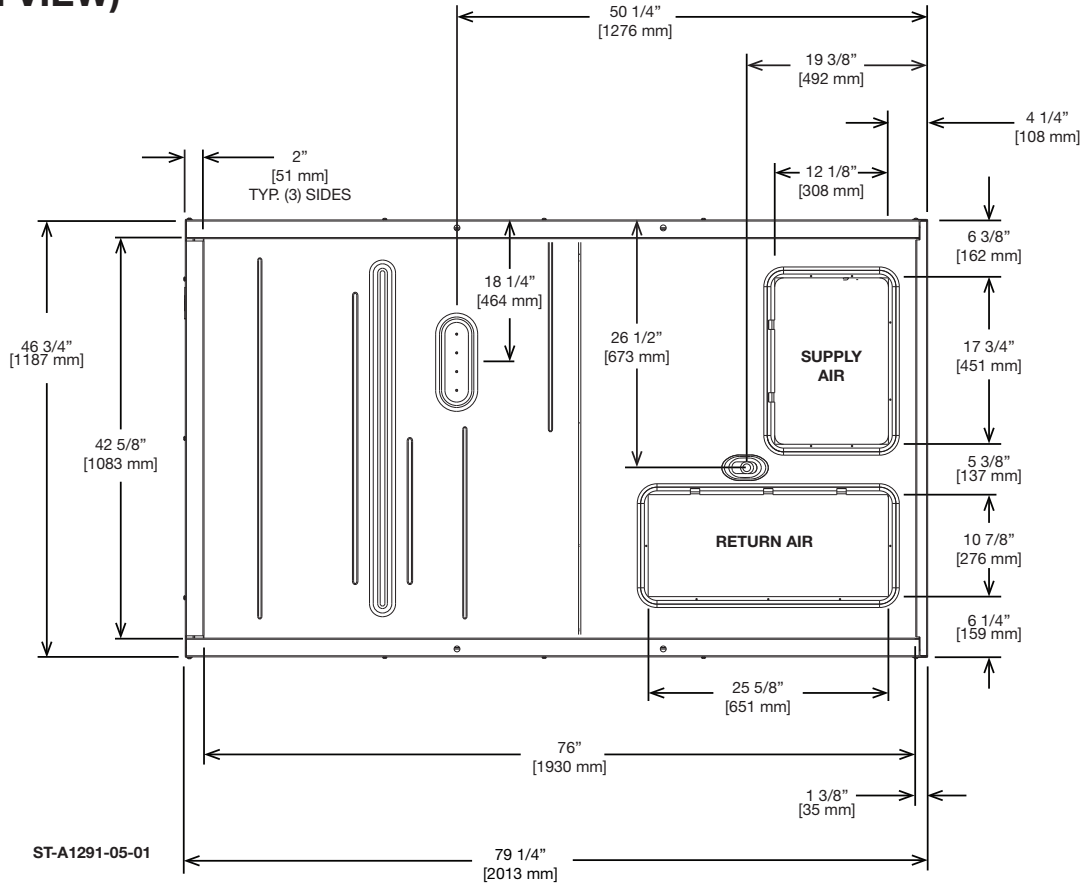

[ ] Designates Metric Conversions

## WEIGHTS

Capacity Tons [kW]	Corner Weights by Percentage			
	A	B	C	D
3.0-6.0 [10.6-21.1]	18%	40%	19%	23%

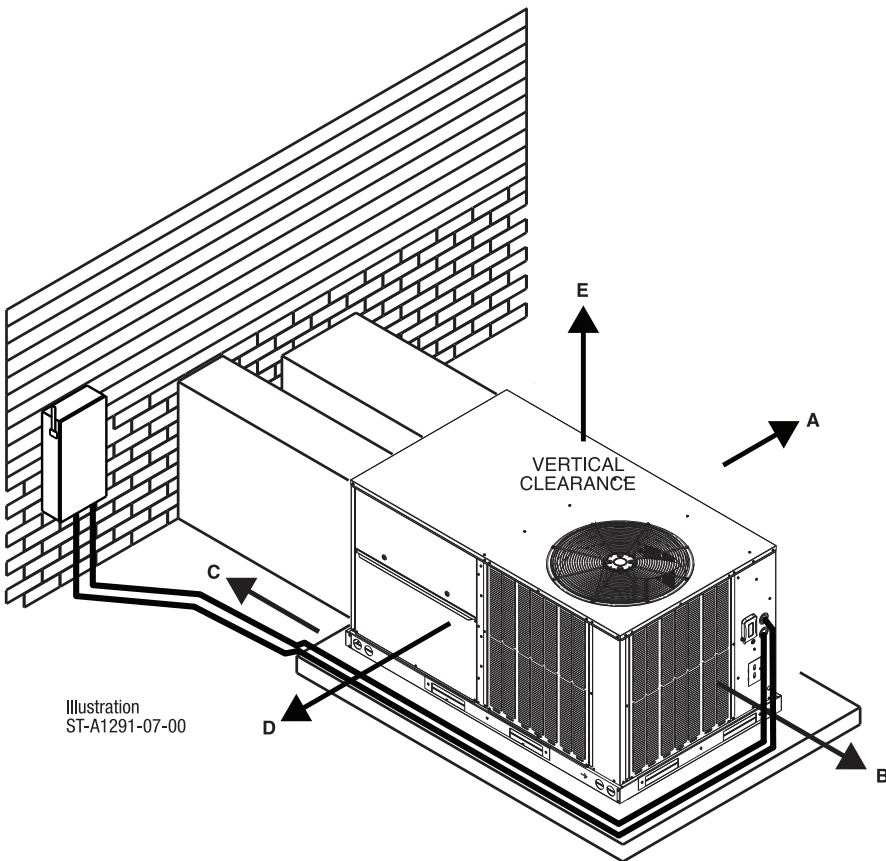
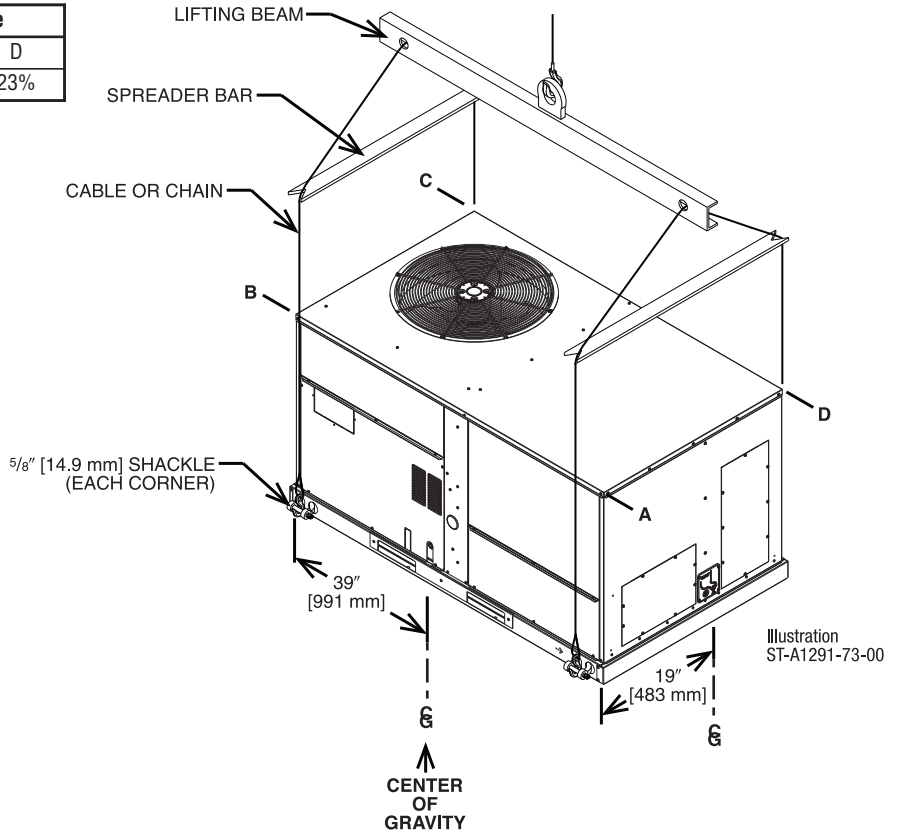

### CLEARANCES

THE FOLLOWING MINIMUM CLEARANCES MUST BE OBSERVED FOR PROPER UNIT PERFORMANCE AND SERVICEABILITY.

RECOMMENDED CLEARANCE In. [mm]	LOCATION
48 [1219]	A - FRONT
24 [609]	B - CONDENSER END
48 [1219] ①	C - DUCT END
24 [609] ②	D - FILTER SIDE
60 [1524]	E - ABOVE

① 18" [457 mm] MINIMUM IF DRAINPAN WILL NOT BE REMOVED.

② 48" [1219 MM] MINIMUM IF ECONOMIZER IS INSTALLED.

[ ] Designates Metric Conversions

## FIELD-INSTALLED ACCESSORY EQUIPMENT

Accessory	Model Number	Shipping Weight Lbs. [kg]	Installed Weight Lbs. [kg]	Factory Installation Available?
Non-DDC Economizer with Single Enthalpy (Downflow) <i>MicroMetl Economizer with Siemens Controls</i>	RXRD-11MCDAM3	100 [45.4]	66 [29.9]	Yes
Non-DDC Economizer with Single Enthalpy (Downflow) <i>RRS Economizer with Siemens Controls</i>	RXRD-51MCDAM3	100 [45.4]	66 [29.9]	No
Non-DDC Economizer with Single Enthalpy (Horizontal) <i>MicroMetl Economizer with Siemens Controls</i>	RXRD-11MCHAM3	72 [32.7]	69 [31.3]	No
Non-DDC Economizer with Single Enthalpy (Horizontal) <i>RRS Economizer with Siemens Controls</i>	RXRD-51MCHAM3	72 [32.7]	69 [31.3]	No
Power Exhaust (230V) Horizontal <i>MicroMetl</i>	RXRX-CCF03C	42 [19.1]	39 [17.7]	No
Power Exhaust (230V) Horizontal <i>RRS</i>	RXRX-RCF03C	42 [19.1]	39 [17.7]	No
Power Exhaust (230V) Vertical <i>MicroMetl</i>	RXRX-CCF02C	24 [10.9]	21 [9.5]	No
Power Exhaust (230V) Vertical <i>RRS</i>	RXRX-RCF02C	24 [10.9]	21 [9.5]	No
Power Exhaust (460V) Horizontal <i>MicroMetl</i>	RXRX-CCF03D	42 [19.1]	39 [17.7]	No
Power Exhaust (460V) Horizontal <i>RRS</i>	RXRX-RCF03D	42 [19.1]	39 [17.7]	No
Power Exhaust (460V) Vertical <i>MicroMetl</i>	RXRX-CCF02D	20 [9.1]	17 [7.7]	No
Power Exhaust (460V) Vertical <i>RRS</i>	RXRX-RCF02D	20 [9.1]	17 [7.7]	No
Concentric Adapter 3 & 4 Ton Drop	RXMC-DC01	35 [15.9]	30 [13.6]	No
Concentric Adapter 5 Ton Drop	RXMC-DC02	40 [18.2]	35 [15.9]	No
Concentric Diffuser 3 & 4 Ton Drop	RXRN-AED1800	35 [15.9]	30 [13.6]	No
Concentric Diffuser 5 Ton Drop	RXRN-AED2000	35 [15.9]	30 [13.6]	No
Concentric Diffuser 3 & 4 Ton Flush	RXRN-AEF1800	30 [13.6]	25 [11.3]	No
Concentric Diffuser 5 Ton Flush	RXRN-AEF2000	30 [13.6]	25 [11.3]	No
Convenience Outlet, Non-Powered	RXRX-BN01	2 [1.0]	1.5 [0.7]	Yes
Electric Heater Kit   208/230V, 1ph, 10kW	RXJJ-DC10JT	10 [4.5]	8 [3.6]	Yes
Electric Heater Kit   208/230V, 1ph, 15kW	RXJJ-DC15JT	13 [5.9]	11 [5.0]	Yes
Electric Heater Kit   208/230V, 1ph, 20kW	RXJJ-DC20JT	14 [6.4]	12 [5.4]	Yes
Electric Heater Kit   208/230V, 3ph, 10kW	RXJJ-DC10CP	10 [4.5]	8 [3.6]	Yes
Electric Heater Kit   208/230V, 3ph, 15kW	RXJJ-DC15CP	13 [5.9]	11 [5.0]	Yes
Electric Heater Kit   208/230V, 3ph, 20kW	RXJJ-DC20CP	14 [6.4]	12 [5.4]	Yes
Electric Heater Kit   460V, 3ph, 10kW	RXJJ-DC10DNV	10 [4.5]	8 [3.6]	Yes
Electric Heater Kit   460V, 3ph, 15kW	RXJJ-DC15DNV	13 [5.9]	11 [5.0]	Yes
Electric Heater Kit   460V, 3ph, 20kW	RXJJ-DC20DNV	14 [6.4]	12 [5.4]	Yes
Fresh Air Damper, Manual	RXRF-ACA1	22 [10.0]	18 [8.2]	No
Fresh Air Damper, Motorized	RXRF-ACB1	53 [24.0]	43 [19.5]	No
MERV 8 Filter	RXMF-M08A21616	2 [0.9]	1 [0.45]	No
MERV 13 Filter	RXMF-M13A21616	2 [0.9]	1 [0.45]	No
Outdoor Coil Louver Kit	RXRX-ADD04C	30 [13.6]	25 [11.3]	Yes
Roofcurb Adapter	RXRX-DCCAE	159 [72.1]	145 [65.8]	No
Roofcurb, 14"	RXKG-DCC14	94 [42.6]	90 [40.8]	No
Roofcurb, 24"	RXKG-DCC24	124 [56.2]	120 [54.4]	No
Single Point Wiring Kit (Single Phase)	RXJX-AJ0601	20 [9.1]	17 [7.7]	No
Single Point Wiring Kit (Three Phase)	RXJX-AZ0601	23 [10.4]	20 [9.1]	No
Unfused Service Disconnect	RXRX-BP01	10 [4.5]	9 [4.1]	Yes
UV-C Light Kit 208/230V	RXRX-UVC22C	8 [3.6]	6 [2.7]	No
UV-C Light Kit Transformer 460V	RXRX-UVCTC	12 [5.4]	11 [5.0]	No
Dual Enthalpy, Temperature and Humidity Sensor ( <i>for Siemens</i> )	PD555460	1 [0.5]	1 [0.5]	No
Low-Ambient Control Kit	RXRZ-A07	4 [1.8]	3 [1.4]	Yes
Sensor, Carbon Dioxide (Wall Mount)	RXRX-AR02	1 [0.5]	1 [0.5]	No
Smoke Detector, Return (Field kit)	RXRX-BS01	7 [3.2]	6 [2.7]	No
Smoke Detector, Return/Supply (Field kit)	RXRX-BS02	5 [2.3]	4 [1.8]	No

[ ] Designates Metric Conversions

# NON-DDC ECONOMIZER WITH SINGLE ENTHALPY (DOWNFLOW) MICROMETL ECONOMIZER WITH SIEMENS CONTROLS

## Factory or Field-Installed

### RXRD-11MCDAM3

PD555460—Sensor, Carbon Dioxide (Wall Mount)

RXR-AR02—Temperature and Humidity Sensor for Dual Enthalpy (for Siemens Controllers Only)

- Features **Siemens** Climatix ECO® Economizer Controller
- Gear Driven Direct Drive Actuator
- Fully Modulating (0-100%)
- Ultra Low Leak Dampers meet California Title 24 Requirements and ASHRAE 90.1 2022
- AMCA® 511 Certified Class 1A Leakage — 1" WG of differential pressure tested to AMCA Standard 500-D
- Slip-In Design for Easy Installation
- Plug-In Polarized 12-pin Electrical Connections
- Standard Barometric Relief Damper
- Single Enthalpy or Dry Bulb with Return Air Enthalpy Option
- CO<sub>2</sub> Input Sensor Option Available
- Field Assembled Hood Ships with Economizer
- Economizer Ships Complete for Downflow Duct Application
- Field-Installed Power Exhaust Option Available
- Fault Detection and Diagnostics

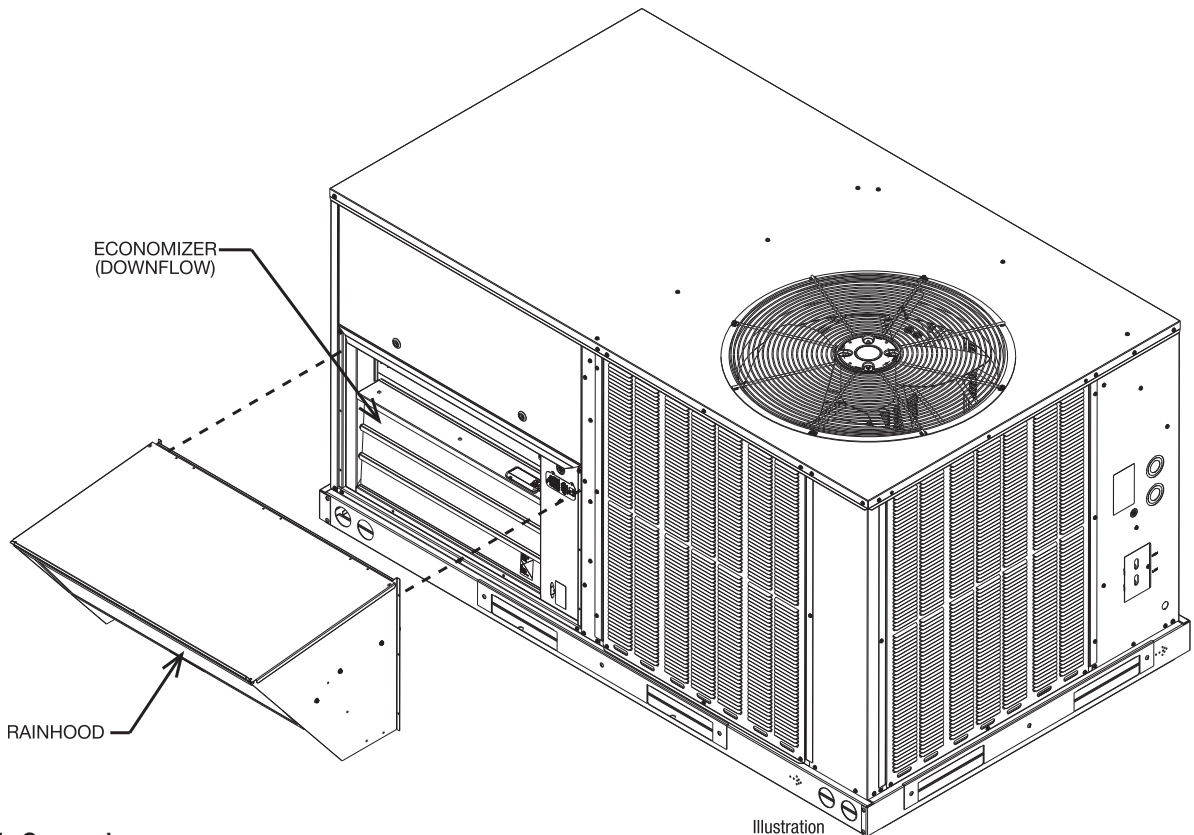
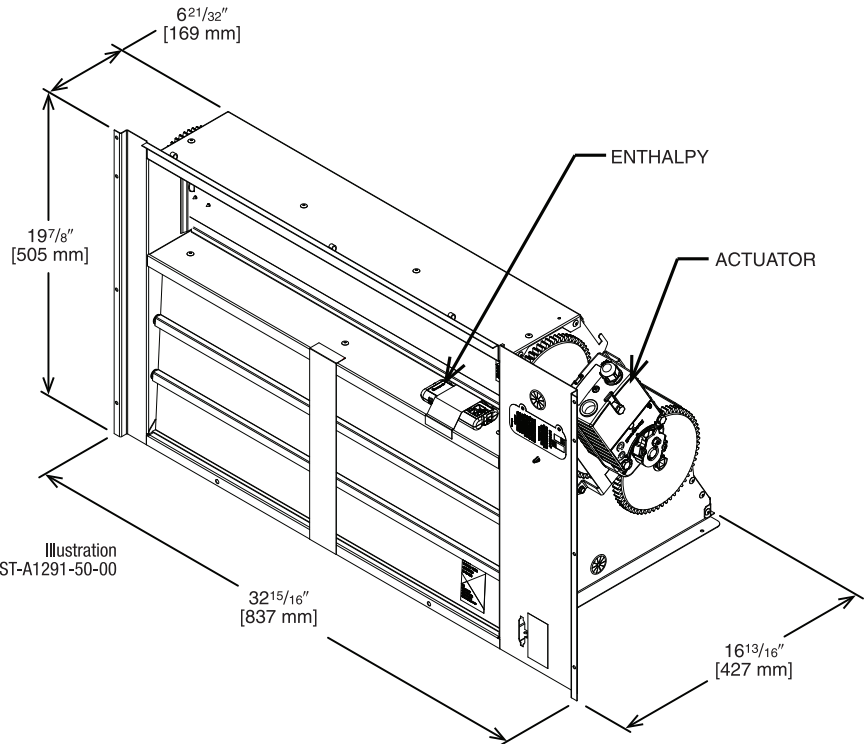

[ ] Designates Metric Conversions

Illustration  
ST-A1291-21-00

# NON-DDC ECONOMIZER WITH SINGLE ENTHALPY (DOWNFLOW) RRS ECONOMIZER WITH SIEMENS CONTROLS

## Field-Installed Only

RXRD-51MCDAM3

PD555460—Dual Enthalpy, Temperature and Humidity Sensor (for Siemens)

RXX-AR02—Sensor, Carbon Dioxide (Wall Mount)

These ultra-low leak economizer dampers meet the following minimum construction standards:

1. Frame shall be 14 to 24 gauge galvanized steel channel.
2. Damper blades are galvanized steel airfoil shaped, double skin construction of 14 gauge [2.0] equivalent thickness, 6" [152 mm] wide.
3. Blade edge seals shall be Ruskiprene type or equivalent suitable for -72°F [-60°C] to +275°F [+135°C] mechanically locked into the blade edge. Adhesive or clip-on type seals are unacceptable.
4. Jamb seals shall be flexible metal, compression type to prevent leakage between blade end and damper frame. Blade end overlapping frame is unacceptable.
5. Bearings shall be stainless steel or nylon bushing.
6. Axles shall be hexagonal positively locked into the damper blade.
7. Drive mechanism shall be concealed out of airstream to reduce pressure drop and noise.
8. Economizer damper is tested and rated based upon AMCA Publication 500-D.
9. Controls feature the Siemens controller and actuator. Controls capable of Economizer Fault Detection and Diagnostics for code compliance.
10. Damper shall meet the leakage requirements of the International Energy Conservation Code by leaking less than 3 CFM/sq. ft. at 1" of static pressure and shall be AMCA licensed as a class 1A damper. Complies with reliability and performance requirements as specified by the California Energy Commission's Title 24 Standard and ASHRAE 90.1 2022. Economizer dampers shall be Ruskin Rooftop Systems ECD60 model.

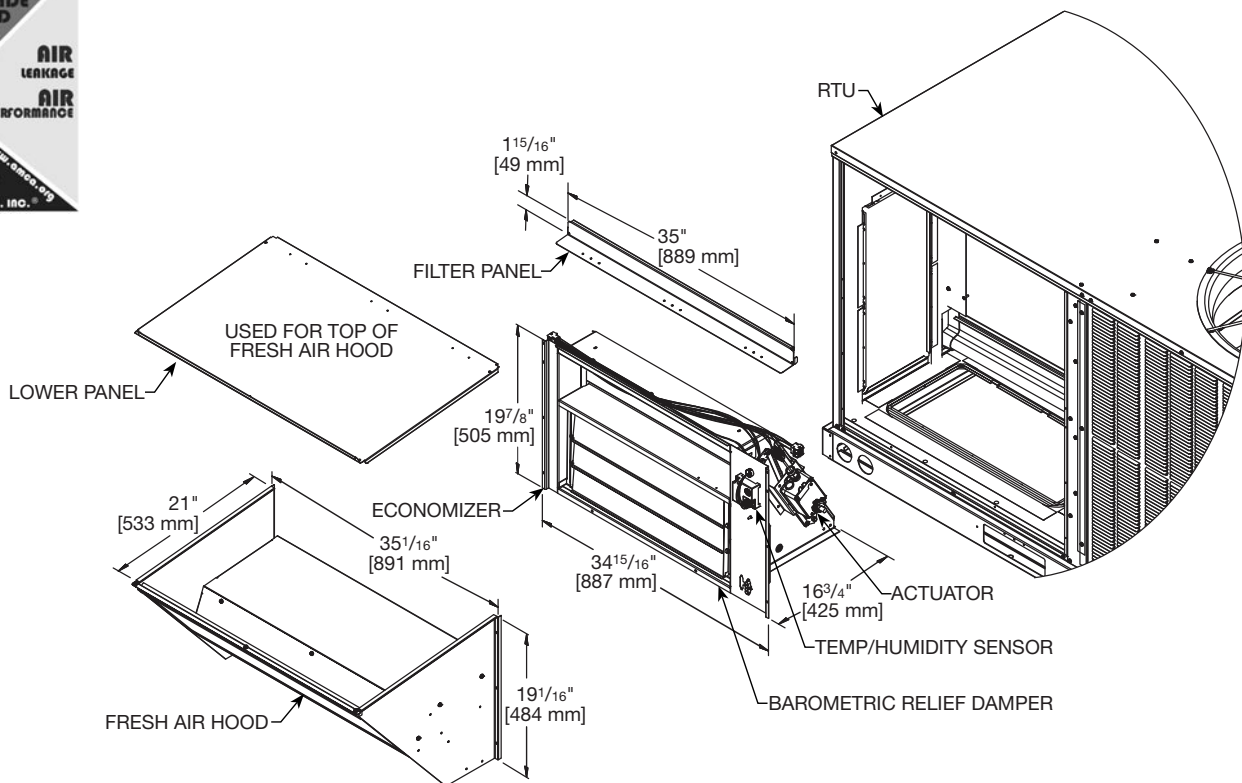

[ ] Designates Metric Conversions

## NON-DDC ECONOMIZER WITH SINGLE ENTHALPY (HORIZONTAL) MICROMETL ECONOMIZER WITH SIEMENS CONTROLS

### Field-Installed Only

#### RXRD-11MCHAM3

PD555460—Dual Enthalpy, Temperature and Humidity Sensor (for Siemens)

RXXR-AR02—Sensor, Carbon Dioxide (Wall Mount)

- Features **Siemens** Climatix ECO Economizer Controller
- Gear Driven Direct Drive Actuator
- Fully Modulating (0-100%)
- Ultra Low Leak Dampers meet California Title 24 Requirements and ASHRAE 90.1 2022
- Slip-In Design for Easy Installation
- Standard Barometric Relief Damper
- Single Enthalpy with Dual Enthalpy Upgrade Kit Available
- CO<sub>2</sub> Input Sensor Option Available
- Field Assembled Hood Ships with Economizer
- Economizer Ships Complete for Horizontal Duct Application
- Field-Installed Power Exhaust Option Available

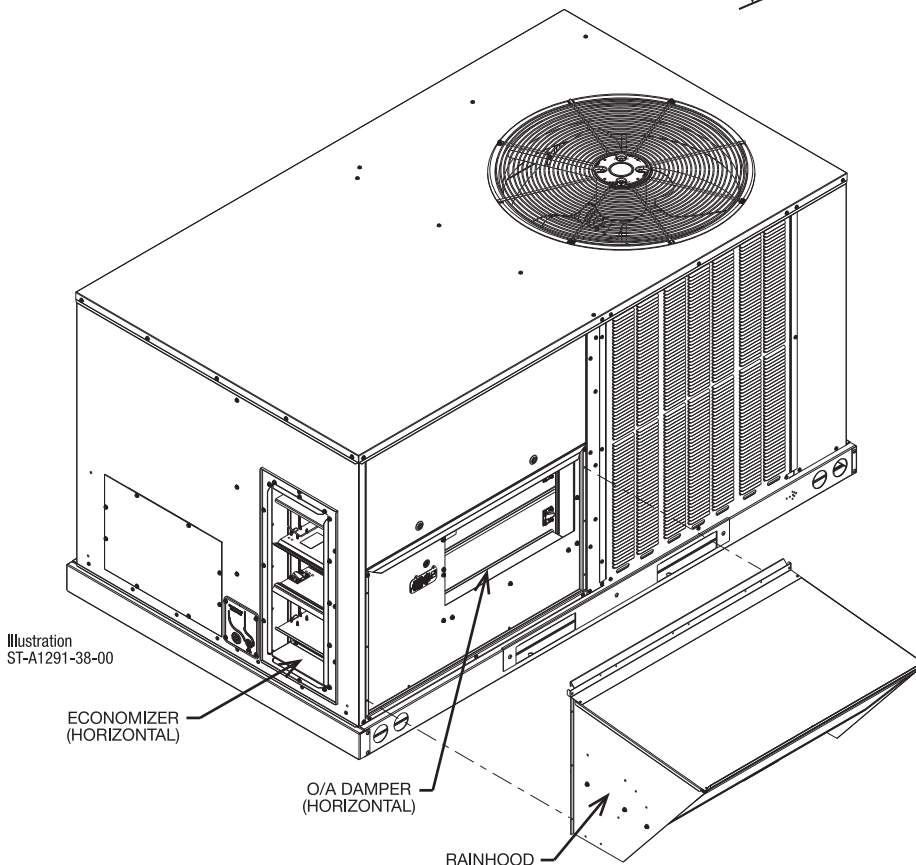
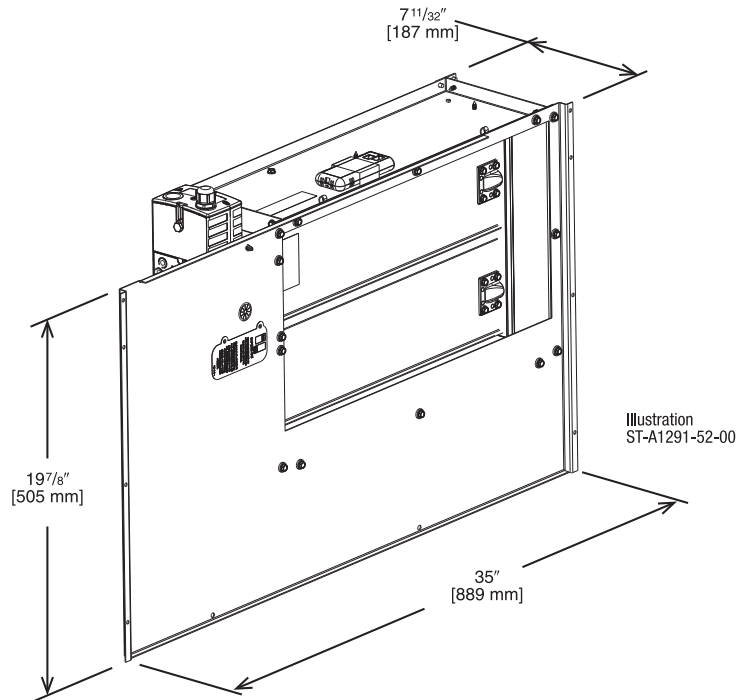

[ ] Designates Metric Conversions

# NON-DDC ECONOMIZER WITH SINGLE ENTHALPY (HORIZONTAL) RRS ECONOMIZER WITH SIEMENS CONTROLS

## Field-Installed Only

RXRD-51MCHAM3

PD555460—Dual Enthalpy, Temperature and Humidity Sensor (for Siemens)

RXXR-AR02—Sensor, Carbon Dioxide (Wall Mount)

These ultra-low leak economizer dampers meet the following minimum construction standards:

1. Frame shall be 14 to 24 gauge galvanized steel channel.
2. Damper blades are galvanized steel airfoil shaped, double skin construction of 14 gauge [2.0] equivalent thickness, 6" [152 mm] wide.
3. Blade edge seals shall be Ruskiprene type or equivalent suitable for -72°F [-60°C] to +275°F [+135°C] mechanically locked into the blade edge. Adhesive or clip-on type seals are unacceptable.
4. Jamb seals shall be flexible metal, compression type to prevent leakage between blade end and damper frame. Blade end overlapping frame is unacceptable.
5. Bearings shall be stainless steel or nylon bushing.
6. Axles shall be hexagonal positively locked into the damper blade.
7. Drive mechanism shall be concealed out of airstream to reduce pressure drop and noise.
8. Economizer damper is tested and rated based upon AMCA Publication 500-D.
9. Controls feature the Siemens controller and actuator. Controls capable of Economizer Fault Detection and Diagnostics for code compliance.
10. Damper shall meet the leakage requirements of the International Energy Conservation Code by leaking less than 3 CFM/sq. ft. at 1" of static pressure and shall be AMCA licensed as a class 1A damper. Complies with reliability and performance requirements as specified by the California Energy Commission's Title 24 Standard and ASHRAE 90.1 2022. Economizer dampers shall be Ruskin Rooftop Systems ECD60 model.

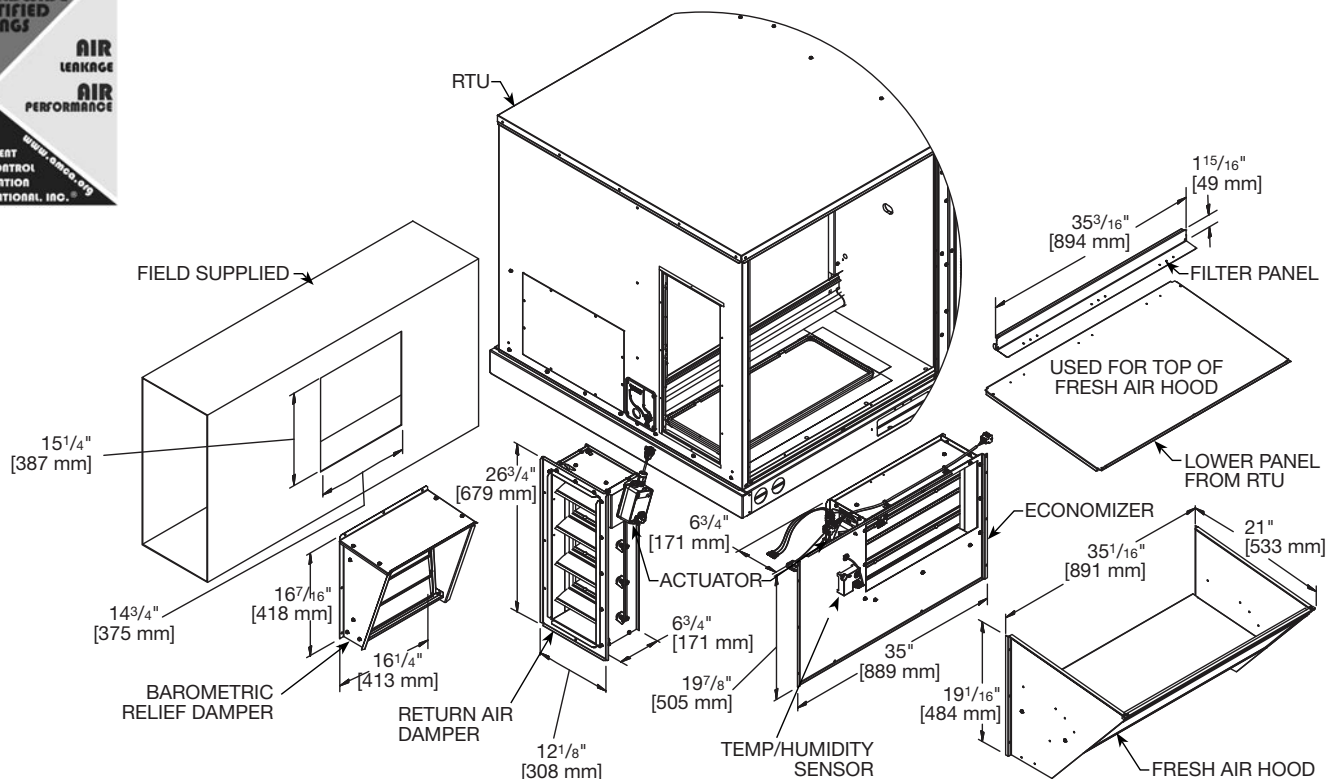

[ ] Designates Metric Conversions

## POWER EXHAUST KIT

RXRX-CCF02\*

\*Voltage Code: C or D

VERTICAL AIRFLOW

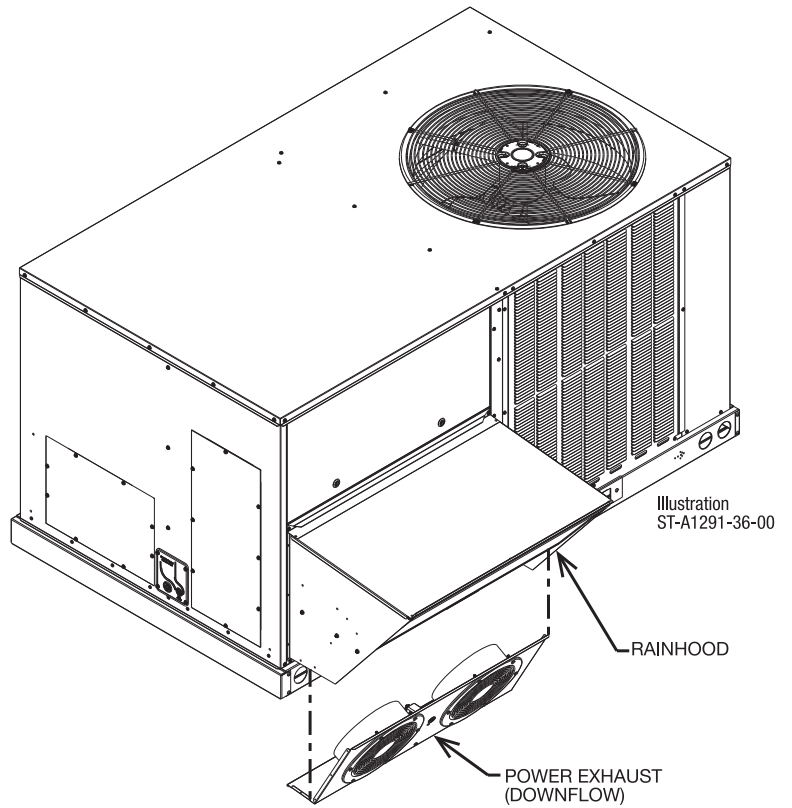

RXRX-CCF03\*

\*Voltage Code: C or D

HORIZONTAL AIRFLOW

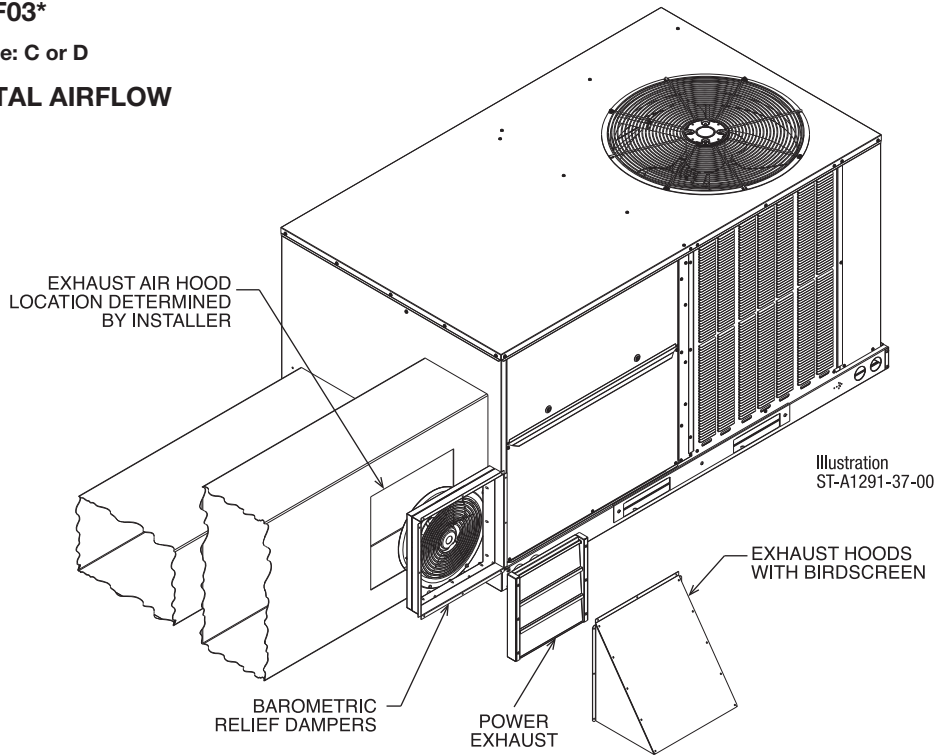

Model No.	No. of Fans	Volts	Phase	HP (ea.)	CFM [L/s]*	RPM	FLA (ea.)	LRA (ea.)
RXRX-CCF0*C	2	208/230	1	0.47	2200	3000	1.55	1.1
RXRX-CCF0*D	2	460	3	0.40	1970	2750	0.51	1.9

## POWER EXHAUST KIT FOR HORIZONTAL ECONOMIZERS

### RXRX-RCF03\*

\*Voltage Code: C or D

- Shipped completely assembled
- All wiring from control box to economizer is supplied
- Fully insulated with 1" 1.5 lb. fiberglass insulation
- Motors are factory wired and tested
- **Economizer with Relief Hood Sold Separately**
- When using this power exhaust system, clearance between the bottom of the unit and the finished roof deck should be a minimum of 10 inches. Some applications may require a taller roofcurb for proper installation.

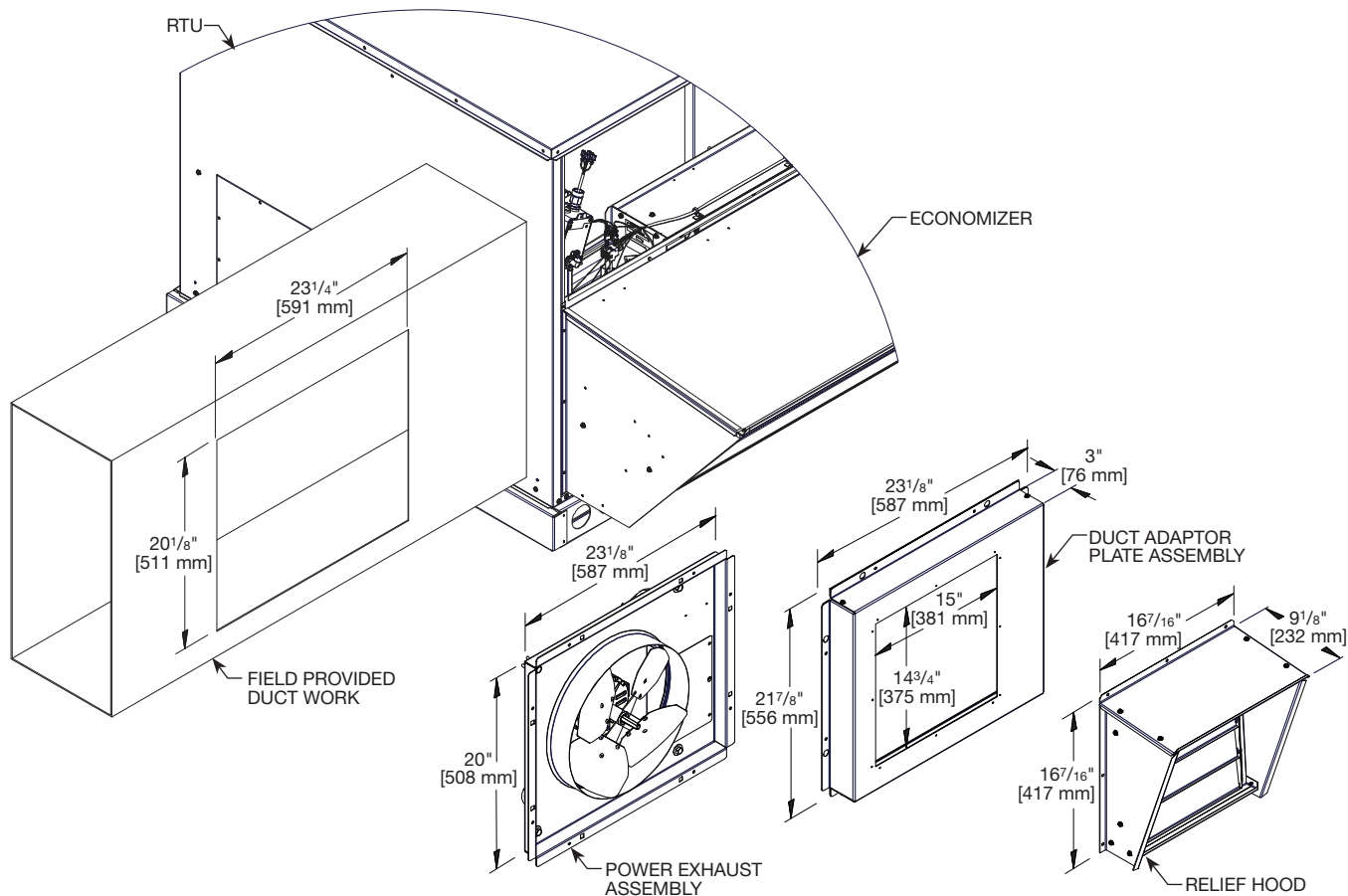

[ ] Designates Metric Conversions

Model No.	Volt	Phase	Motor				Unit				@ 0.1 CFM
			HP	RPM	LRA	Qty.	Cir. Qty.	FLA	MCA	Fuse Size	
RXRX-RCF03C	208/230	1	1/2	1625	5.86	1	1	2.70	3.38	6	2013
RXRX-RCF03D	460				3.33			1.34	1.68	3	

## POWER EXHAUST KIT FOR DOWNFLOW ECONOMIZERS

### RXRX-RCF02\*

\*Voltage Code: C or D

- Shipped completely assembled
- All wiring from control box to economizer is supplied
- Fully insulated with 1" 1.5 lb. fiberglass insulation
- Motors are factory wired and tested
- **Economizer Sold Separately**
- When using this power exhaust system, clearance between the bottom of the unit and the finished roof deck should be a minimum of 10 inches. Some applications may require a taller roofcurb for proper installation.

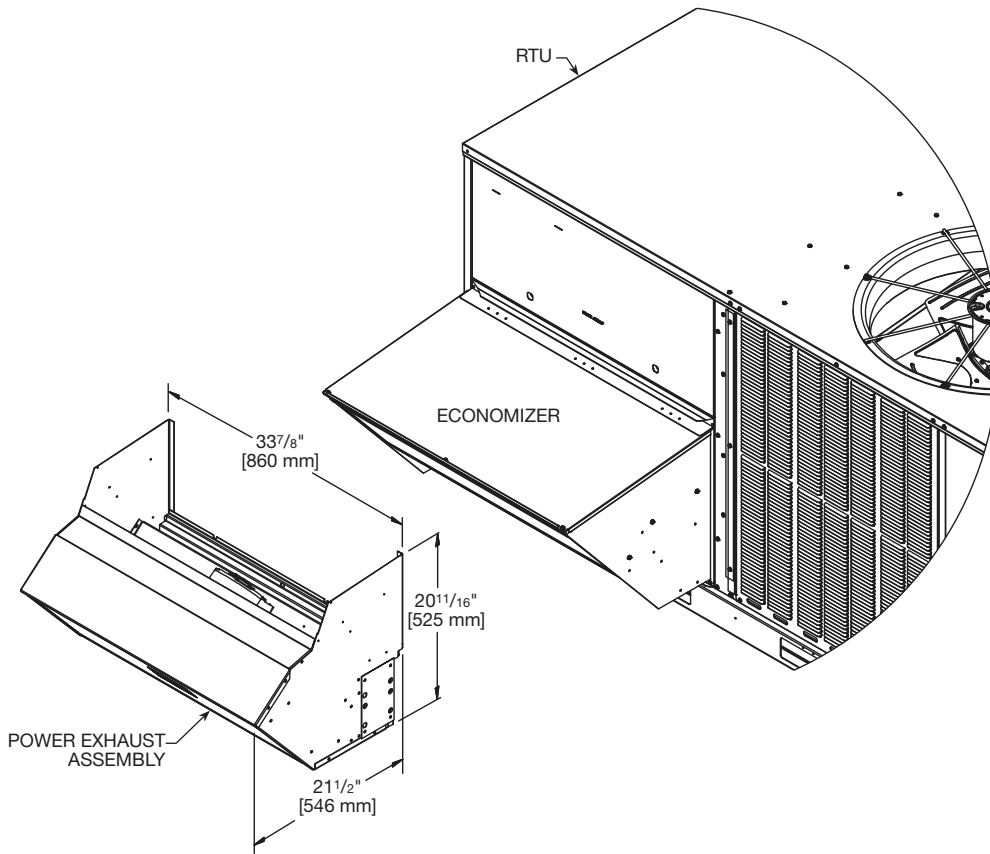

[ ] Designates Metric Conversions

Model No.	Volt	Phase	Motor				Unit				@ 0.1 CFM
			HP	RPM	LRA	Qty.	Cir. Qty.	FLA	MCA	Fuse Size	
RXRX-RCF02C	208/230	1	1/2	1625	5.86	1	1	2.70	3.38	6	1989
RXRX-RCF02D	460				3.33			1.34	1.68	3	

# CONCENTRIC DIFFUSER APPLICATION

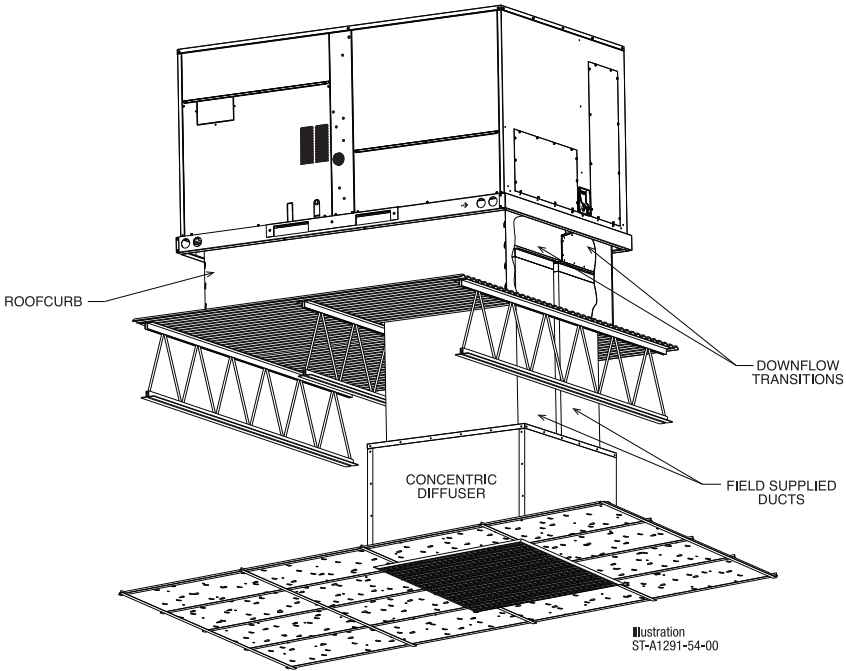

## DOWNFLOW TRANSITION DRAWINGS

### RXMC-DC01 – Concentric Adapter 3 & 4 Ton Drop

- Used with RXRN-AEF1800 or RXRN-AED1800 Concentric Diffusers

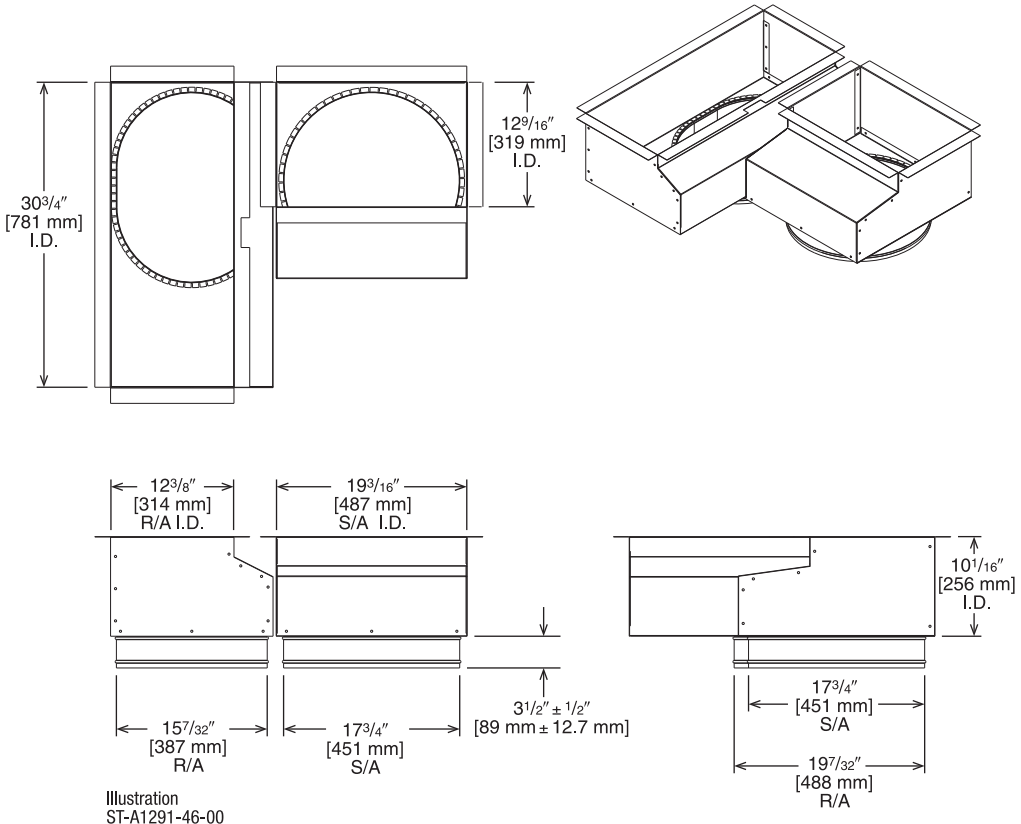

[ ] Designates Metric Conversions

# DOWNFLOW TRANSITION DRAWINGS

## RXMC-DC02—Concentric Adapter 5 Ton Drop

- Used with RXRN-AEF2000 or RXRN-AED2000 Concentric Diffusers

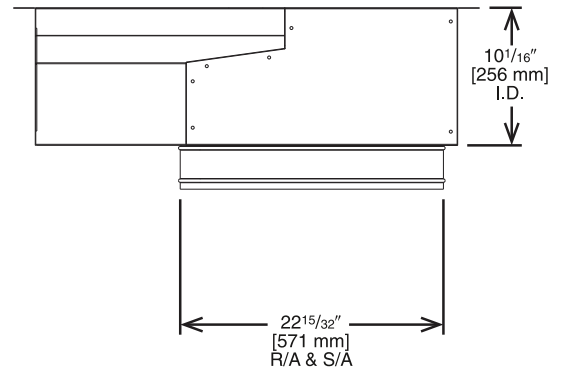
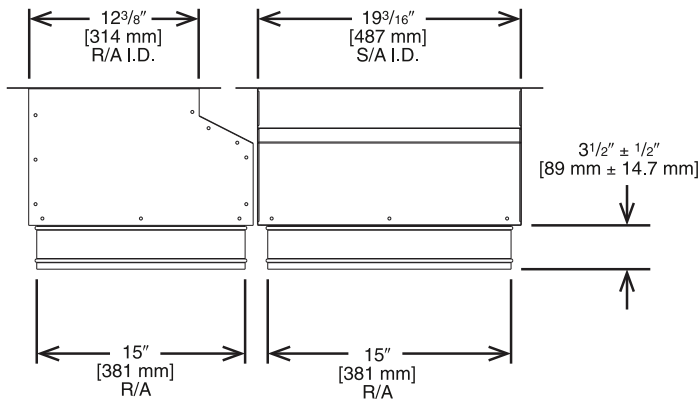
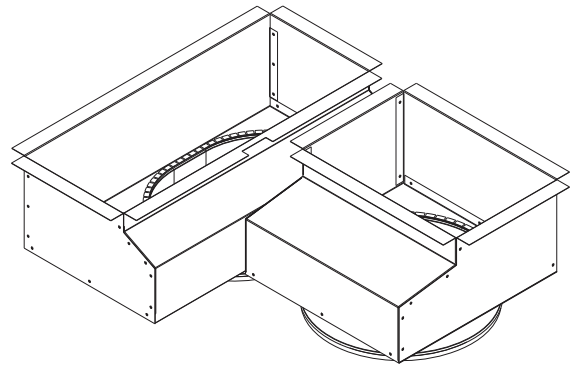
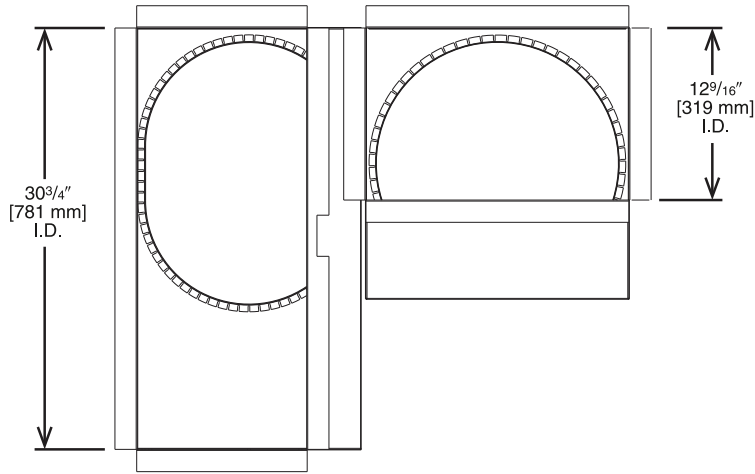

Illustration  
 ST-A1291-47-00

[ ] Designates Metric Conversions

## CONCENTRIC DIFFUSER 3 & 4 TON DROP

RXRN-AED1800

For Use With Downflow Transition (RXMC-DC01) and 18" Round Supply and Return Ducts

- All aluminum diffuser with aluminum return air eggcrate
- Built-in anti-sweat gasket
- Molded fiberglass supports
- Built-in hanging supports
- Diffuser box constructed of sheet metal insulated with 1" [25.4 mm] 1.5 lbs. [.7 kg] duct liner

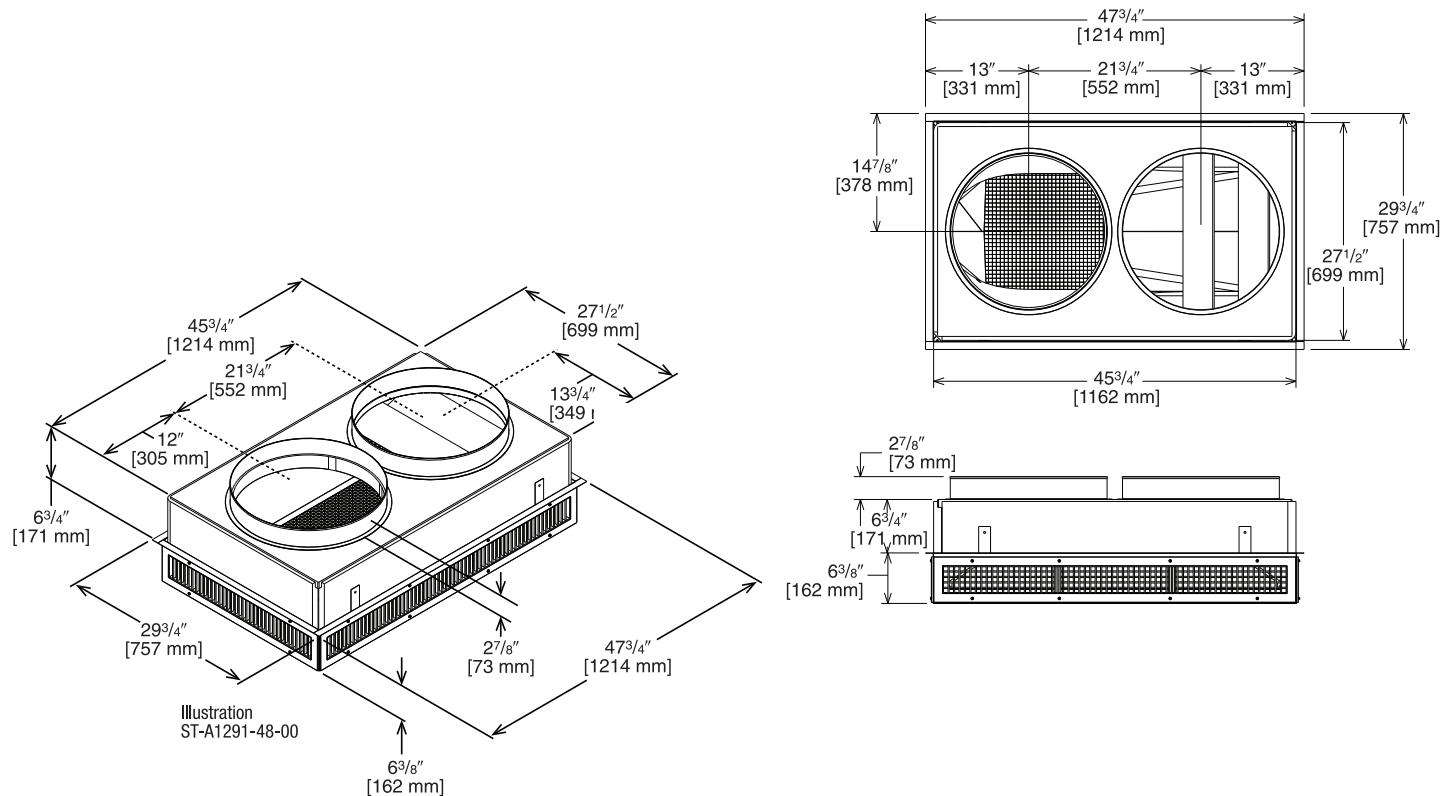

### ENGINEERING DATA<sup>①</sup>

Model No.	Flow Rate CFM [L/s]	Throw <sup>② ③</sup> Feet [m]	Neck Velocity fpm [m/s]	Noise Level <sup>④</sup> (dbA)
RXRN-AED1800	1000 [472]	9-23 [2.7-7.0]	391 [2.0]	12
	1200 [566]	10-24 [3.0-7.3]	469 [2.4]	15
	1400 [661]	12-26 [3.7-7.9]	547 [2.8]	19
	1600 [755]	13-28 [4.0-8.5]	625 [3.2]	21
	1800 [849]	15-30 [4.6-9.1]	703 [3.6]	26
	2000 [944]	17-32 [5.2-9.8]	781 [4.0]	30
	2400 [1133]	19-34 [5.8-10.4]	859 [5.8]	32

NOTES: ① All data is based on the air diffusion council guidelines.

② Throw data is based on 75 FPM Terminal Velocities using isothermal air.

③ Throw is based on diffuser blades being directed in a straight pattern.

④ Actual noise levels may vary due to duct design and do not include transmitted unit noise. Adequate duct attenuation must be provided to reduce sound output from the unit.

[ ] Designates Metric Conversions

# CONCENTRIC DIFFUSER 5 TON DROP

## RXRN-AED2000

For Use With Downflow Transition (RXMC-DC02) and 20" Round Supply and Return Ducts

- All aluminum diffuser with aluminum return air eggcrate
- Built-in anti-sweat gasket
- Molded fiberglass supports
- Built-in hanging supports
- Diffuser box constructed of sheet metal insulated with 1" [25.4 mm] 1.5 lbs. [.7 kg] duct liner

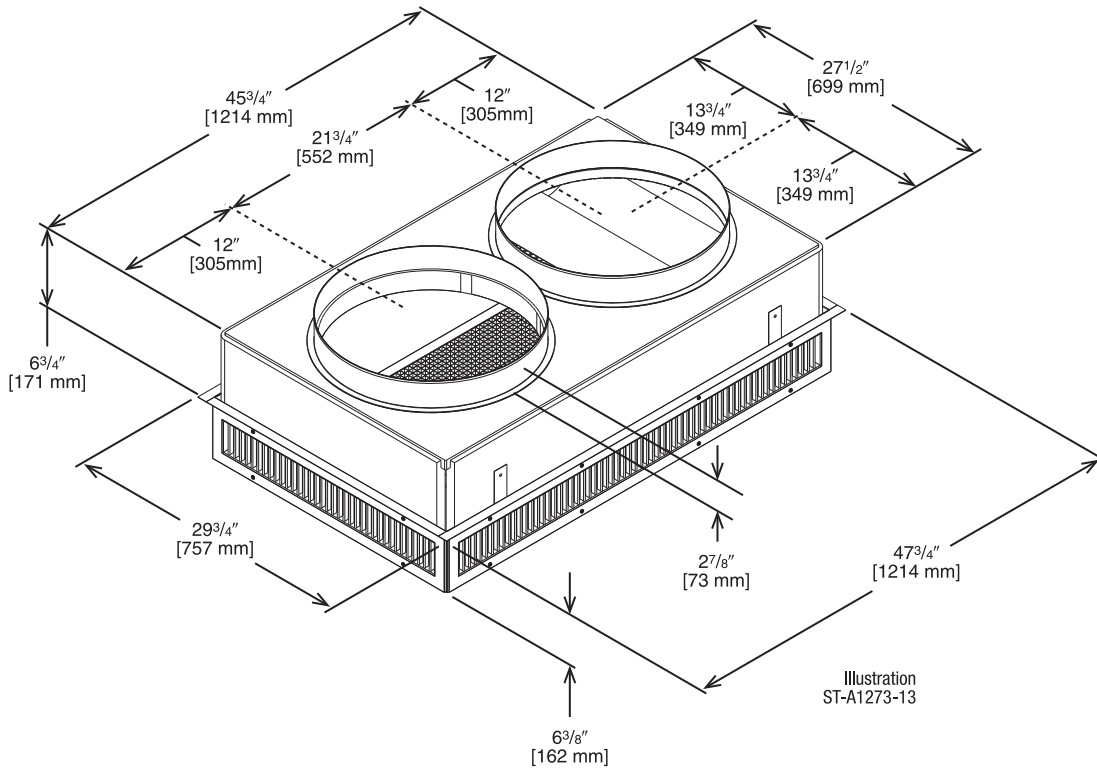

## ENGINEERING DATA<sup>①</sup>

Model No.	Flow Rate CFM [L/s]	Throw <sup>② ③</sup> Feet [m]	Neck Velocity fpm [m/s]	Noise Level <sup>④</sup> (dbA)
RXRN-AED2000	2600 [1222]	22-39 [6.7-11.9]	669 [3.4]	32
	2800 [1316]	23-40 [7.1-12.2]	720 [3.7]	38
	3000 [1410]	25-42 [7.6-12.8]	772 [3.9]	40
	3200 [1504]	26-43 [7.9-13.1]	823 [4.2]	41
	3400 [1598]	27-45 [8.2-13.7]	874 [4.4]	42

- NOTES:** ① All data is based on the air diffusion council guidelines.  
 ② Throw data is based on 75 FPM Terminal Velocities using isothermal air.  
 ③ Throw is based on diffuser blades being directed in a straight pattern.  
 ④ Actual noise levels may vary due to duct design and do not include transmitted unit noise.  
 Adequate duct attenuation must be provided to reduce sound output from the unit.

[ ] Designates Metric Conversions

# CONCENTRIC DIFFUSER 3 & 4 TON FLUSH

RXRN-AEF1800

For Use With Downflow Transition (RXMC-DC01) 18" Round Supply and Return Ducts

- All aluminum diffuser with aluminum return air eggcrate
- Built-in anti-sweat gasket
- Molded fiberglass supports
- Built-in hanging supports
- Diffuser box constructed of sheet metal insulated with 1" [25.4 mm] 1.5 lbs. [.7 kg] duct liner

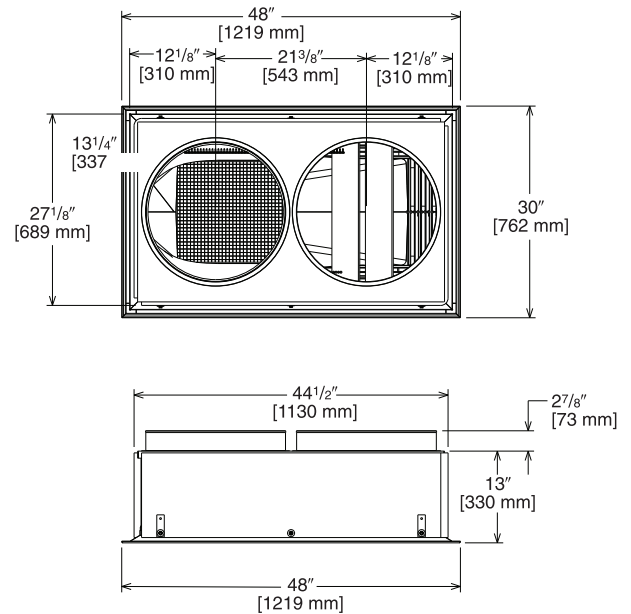
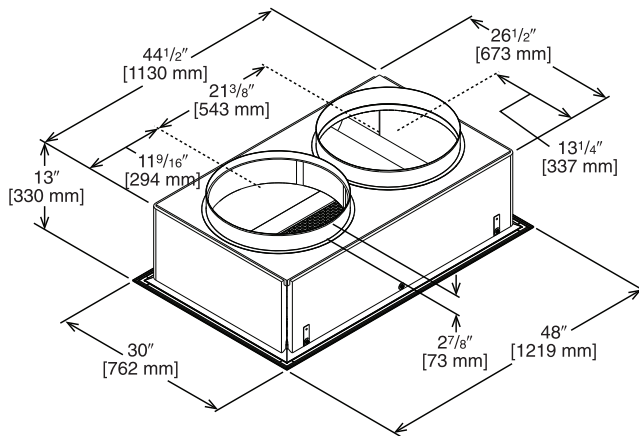

Illustration  
ST-A1291-49-00

## ENGINEERING DATA<sup>①</sup>

Model No.	Flow Rate CFM [L/s]	Throw <sup>② ③</sup> Feet [m]	Neck Velocity fpm [m/s]	Noise Level <sup>④</sup> (dB)
RXRN-AEF1800	1000 [472]	9-12 [2.7-3.7]	663 [3.4]	20
	1200 [566]	12-16 [3.7-4.9]	714 [3.6]	25
	1400 [661]	15-20 [4.6-6.1]	765 [3.9]	30
	1600 [755]	17-23 [5.2-7]	816 [4.1]	30
	1800 [849]	20-26 [6.1-7.9]	867 [4.4]	35
	2000 [944]	22-29 [6.7-8.8]	918 [4.7]	40
	2400 [1133]	25-32 [7.6-9.8]	969 [4.9]	45

- NOTES:** ① All data is based on the air diffusion council guidelines.  
 ② Throw data is based on 75 FPM Terminal Velocities using isothermal air.  
 ③ Throw is based on diffuser blades being directed in a straight pattern.  
 ④ Actual noise levels may vary due to duct design and do not include transmitted unit noise.  
 Adequate duct attenuation must be provided to reduce sound output from the unit.

[ ] Designates Metric Conversions

# CONCENTRIC DIFFUSER 5 TON FLUSH

## RXRN-AEF2000

For Use With Downflow Transition (RXMC-DC02) 20" Round Supply and Return Ducts

- All aluminum diffuser with aluminum return air eggcrate
- Built-in anti-sweat gasket
- Molded fiberglass supports
- Built-in hanging supports
- Diffuser box constructed of sheet metal insulated with 1" [25.4 mm] 1.5 lbs. [.7 kg] duct liner

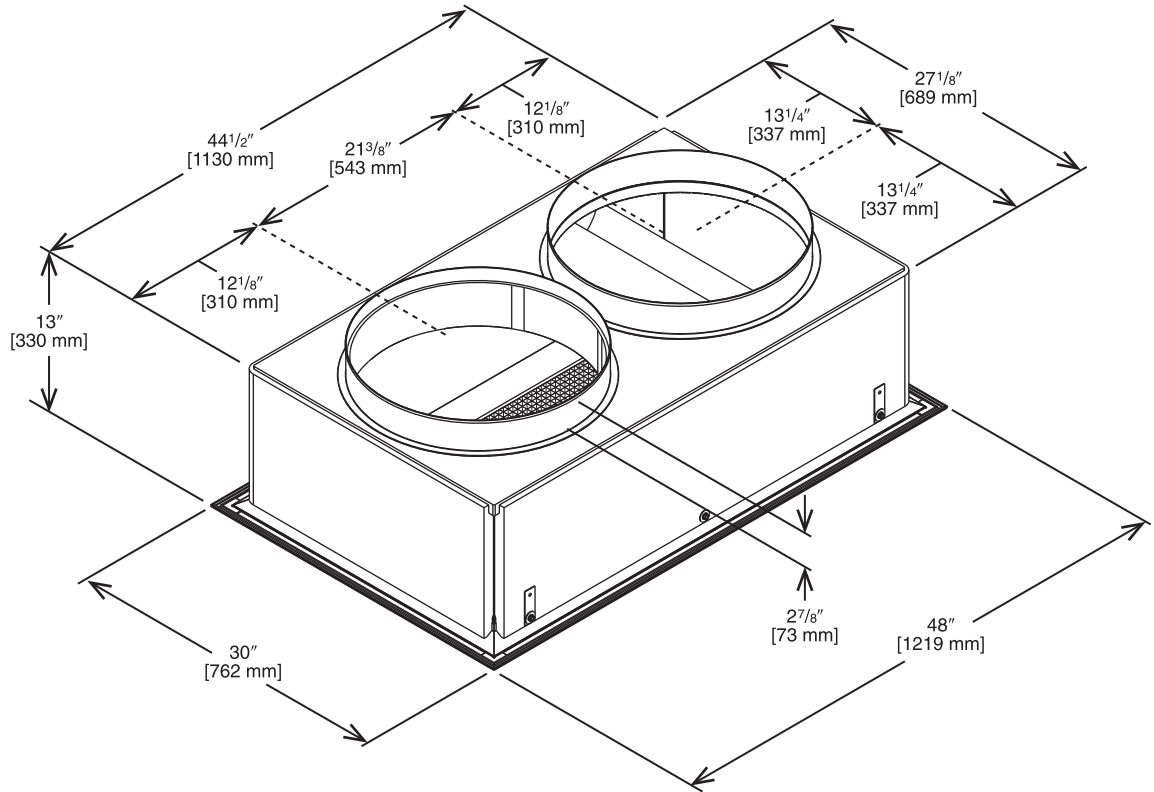

Illustration  
ST-A1273-14-00

## ENGINEERING DATA<sup>①</sup>

Model No.	Flow Rate CFM [L/s]	Throw <sup>② ③</sup> Feet [m]	Neck Velocity fpm [m/s]	Noise Level <sup>④</sup> (dbA)
RXRN-AEF2000	2600 [1222]	17-24 [5.2-7.3]	663 [3.4]	30
	2800 [1316]	18-28 [5.5-8.5]	714 [3.6]	35
	3000 [1410]	20-30 [6.1-9.1]	765 [3.9]	35
	3200 [1504]	22-33 [6.7-10.1]	816 [4.1]	40
	3400 [1598]	23-37 [7-11.3]	867 [4.4]	40

- NOTES:** ① All data is based on the air diffusion council guidelines.  
 ② Throw data is based on 75 FPM Terminal Velocities using isothermal air.  
 ③ Throw is based on diffuser blades being directed in a straight pattern.  
 ④ Actual noise levels may vary due to duct design and do not include transmitted unit noise.  
 Adequate duct attenuation must be provided to reduce sound output from the unit.

[ ] Designates Metric Conversions

## FRESH AIR DAMPER

RXRF-ACA1 – Manual Damper Kit

### DOWNFLOW APPLICATION

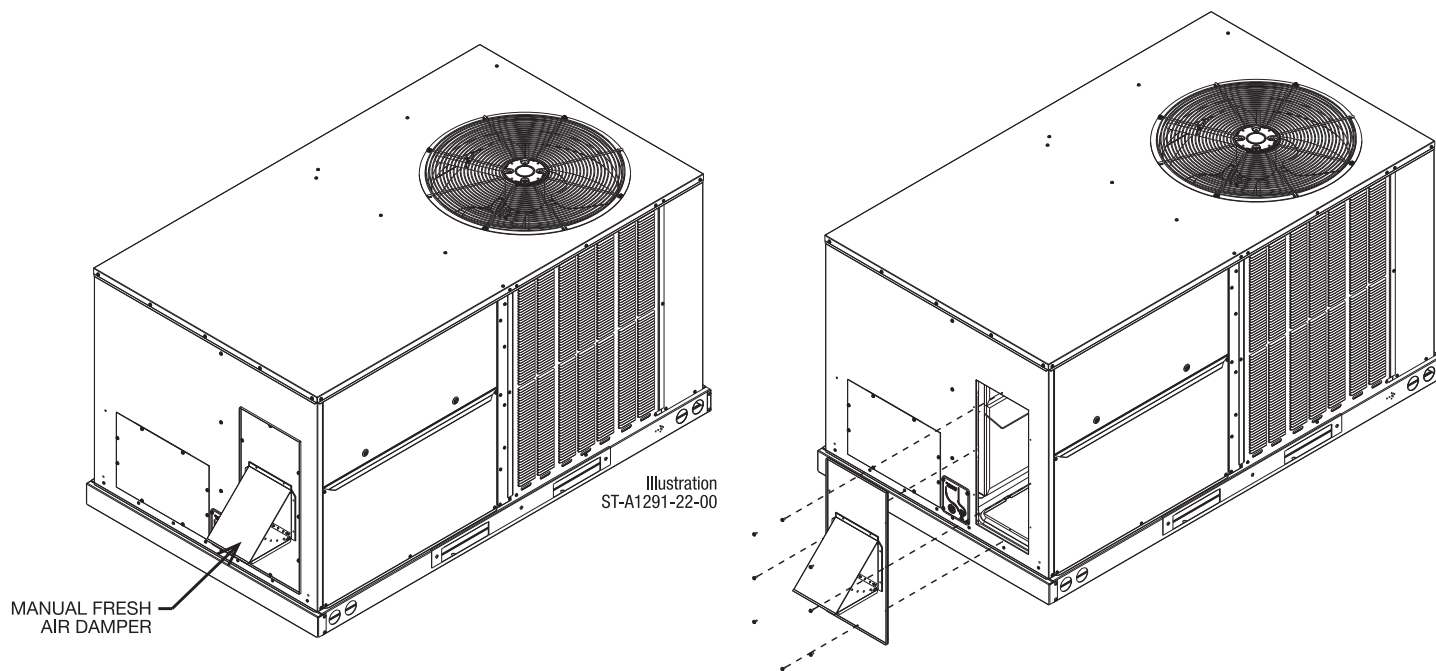

### HORIZONTAL APPLICATION

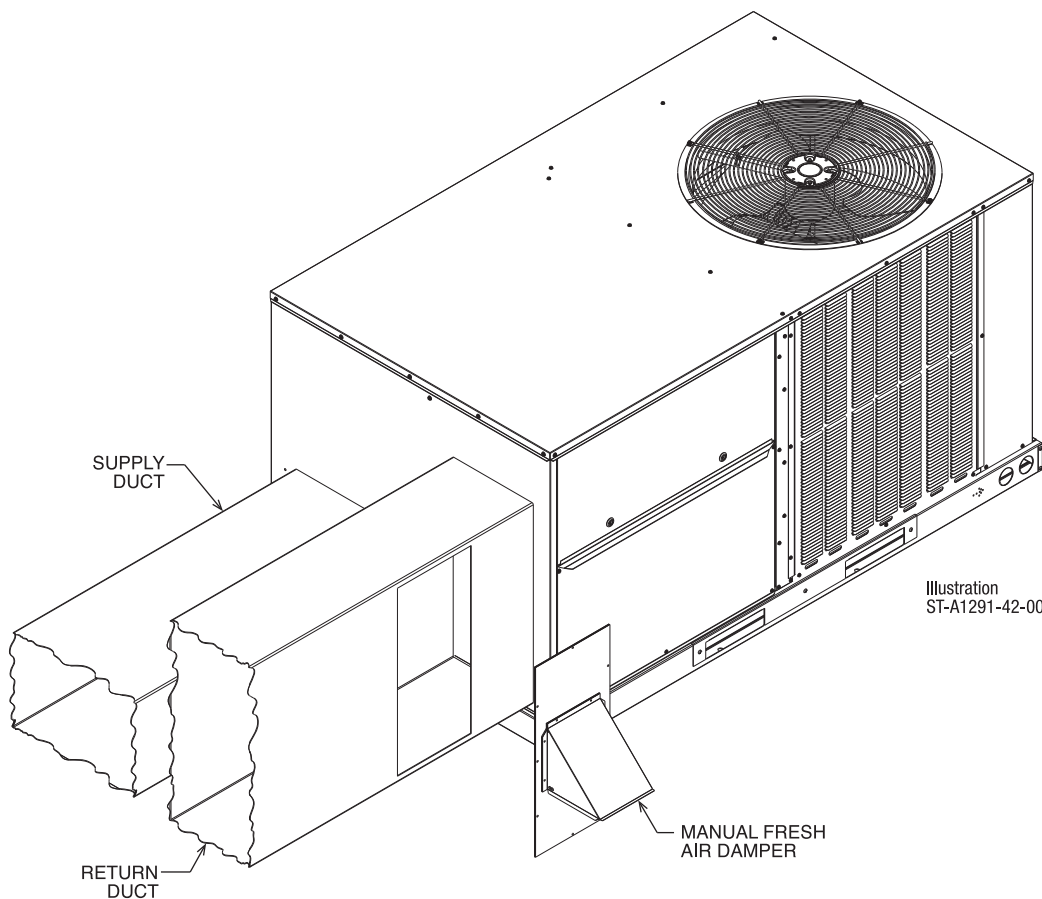

## FRESH AIR DAMPER

### RXRF-ACB1 – Motorized Damper Kit

- Features **Siemens** Actuator
- Gear Driven Direct Drive Actuator
- Adjustable to 2 positions
- Slip-In Design for Easy Installation
- Plug-In Polarized 12-pin and 4-pin Electrical Connections
- Pre-Configured—No Field Adjustments Necessary

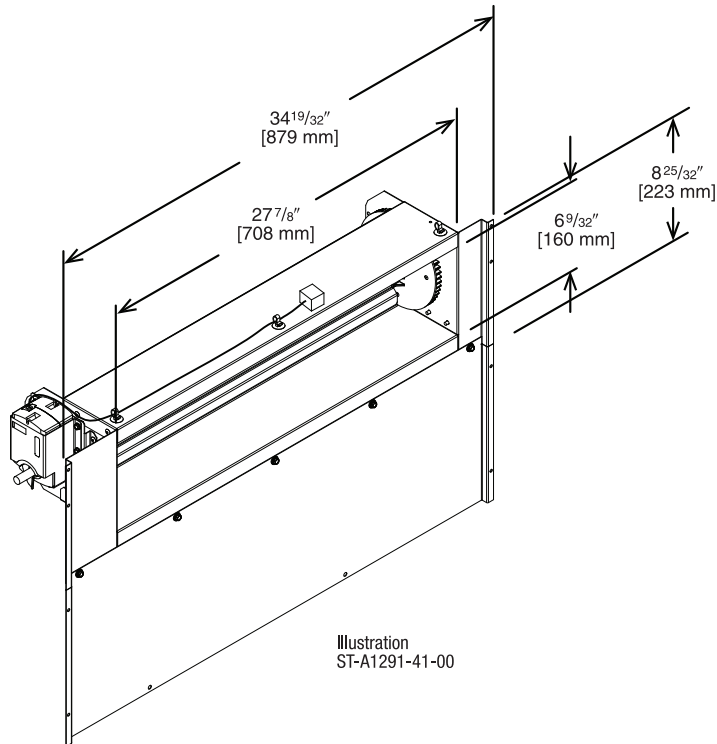

[ ] Designates Metric Conversions

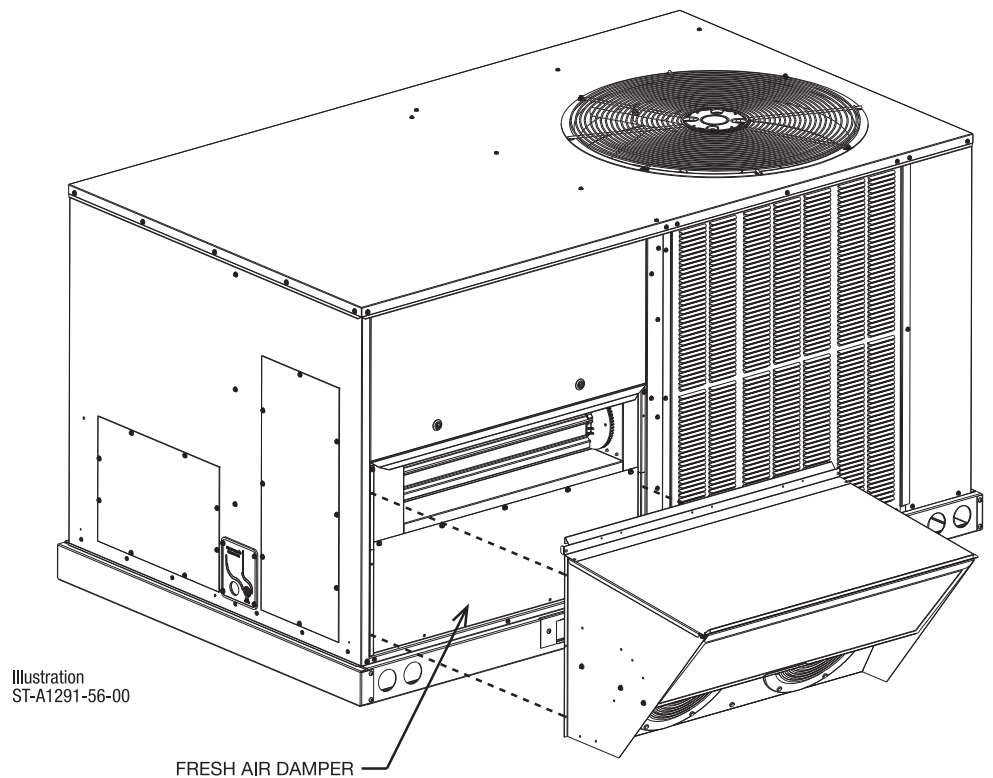

# ROOFCURB ADAPTERS

## RXXR-DCCAE

- This roofcurb adapter fits the previous generation footprint (for example, RKNL, RLRL, RJNL series)

### SIDE VIEW

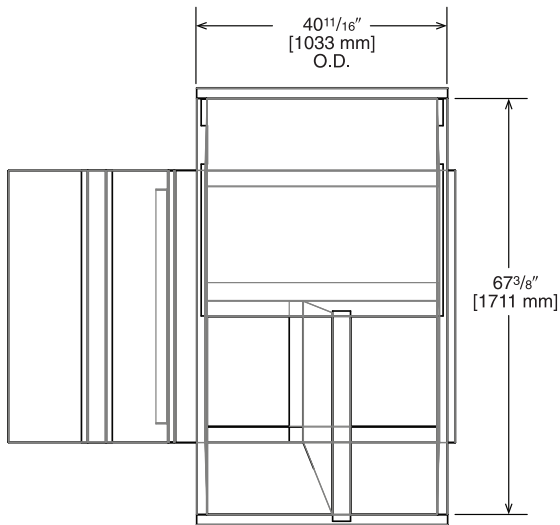

Approximate Static Pressure Drop
@1200 CFM = 0.05" w.g.
@2000 CFM = 0.19" w.g.

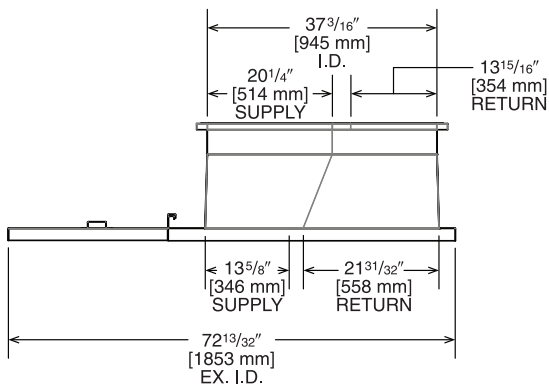
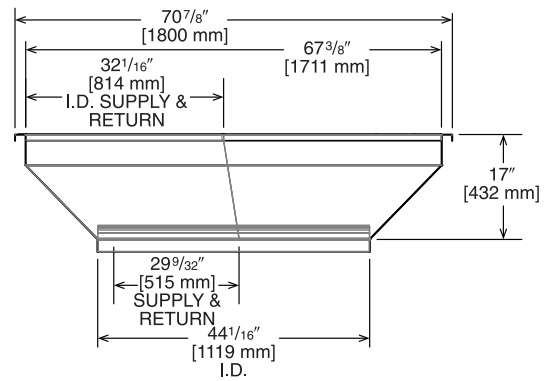

Illustration  
ST-A1291-44-00



### TOP VIEW

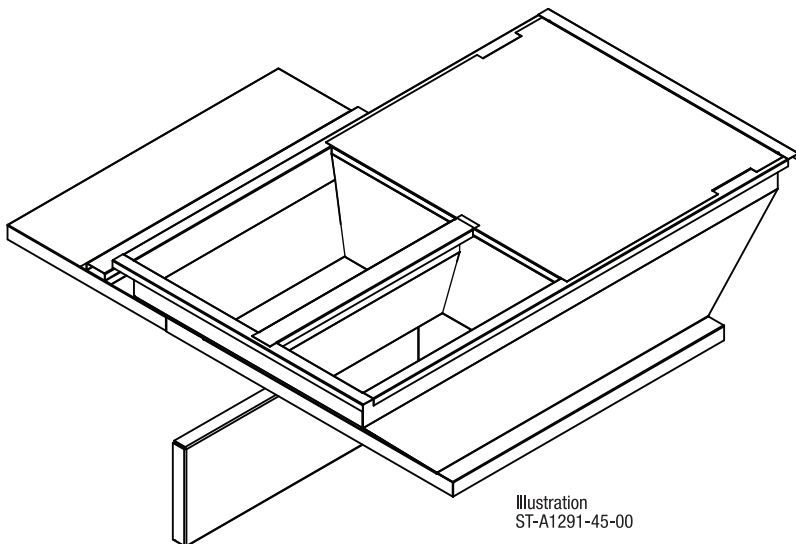
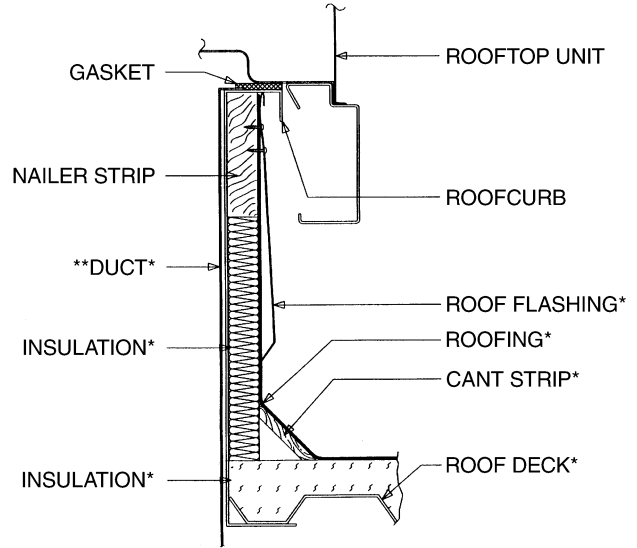

Illustration  
ST-A1291-45-00

[ ] Designates Metric Conversions

## ROOFCURBS (Full Perimeter)

- The roofcurb design can be utilized on all 3-5 Ton RHPCYC- models
- Two available heights (14" [356 mm] and 24" [610 mm]) for ALL models
- Quick assembly corners for simple and fast assembly
- Opening provided in bottom pan to match the "Thru the Curb" electrical, gas piping, condensate, connection opening provided on the unit base pan
- 1" [25 mm] x 4" [102 mm] Nailers provided
- Sealing gasket (40' [12.2 m]) provided with Roofcurb
- Packaged for easy field assembly



\*BY CONTRACTOR

\*\*FOR INSTALLATION OF DUCT AS SHOWN, USE RECOMMENDED DUCT SIZES FROM ROOFCURB INSTALLATION INSTRUCTIONS. FOR DUCT FLANGE ATTACHMENT TO UNIT, SEE UNIT INSTALLATION INSTRUCTIONS FOR RECOMMENDED DUCT SIZES.

### ROOFCURB INSTALLATION—VIEW A

Illustration  
 ST-A0743-02

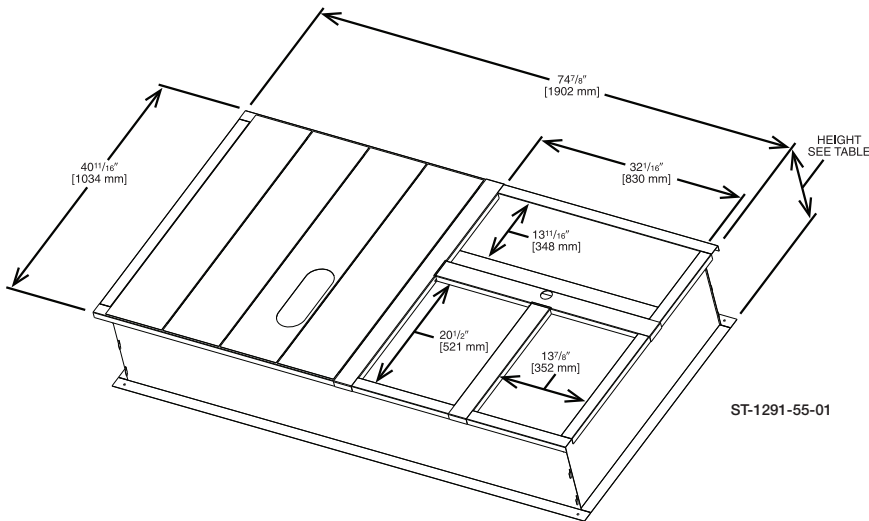

ST-1291-55-01

View	Roofcurb Model	Height of Curb
A	RXKG-DCC14	14" [356 mm]
A	RXKG-DCC24	24" [610 mm]

• **State of Florida Approved:** Florida approval #26981 and corresponding Technical Evaluation Report (TER) number are available under separate copy. Unit and mounting methods are for high wind resistance and are compliant per Florida Building Code.

[ ] Designates Metric Conversions

## ELECTRIC HEAT AND SINGLE POINT WIRING

The field or factory electric heater kits are available in 10, 15 and 20 kW heating inputs, and for both single and 3-phase applications. The single point wiring kit is only available as a field installation accessory for units using electric heat.

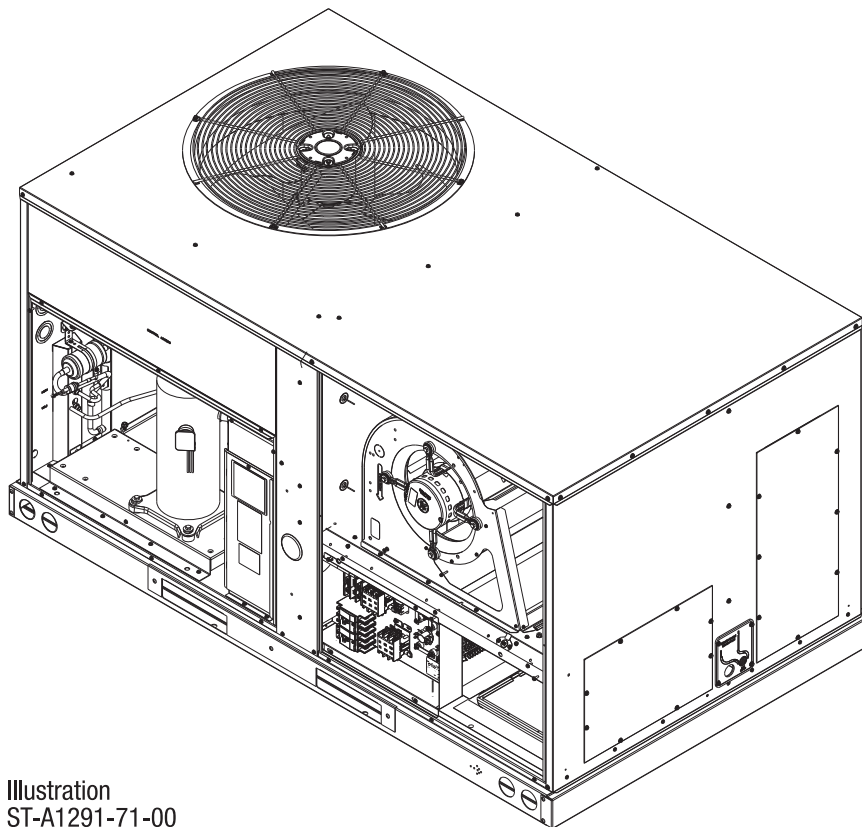
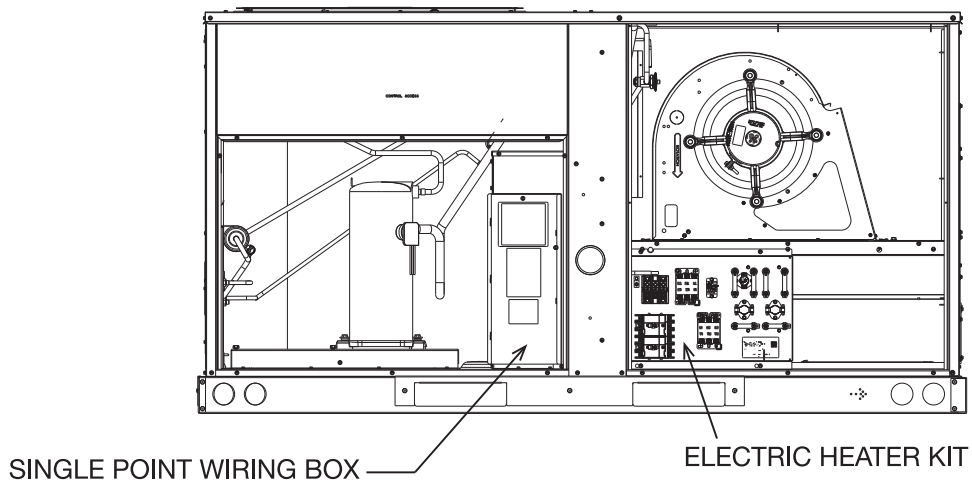

Illustration  
ST-A1291-71-00



## Guide Specifications RHPCYC-036— 060

You may copy this document directly into your building specification. This specification is written to comply with the 2016 version of the “master format” as published by the Construction Specification Institute. [www.csinet.org](http://www.csinet.org).

### ELECTRIC HEAT PACKAGED ROOFTOP

#### HVAC Guide Specifications

#### Size Range: 3 to 5 Nominal Tons

##### 1.00 General:

- A. Outdoor, rooftop mounted, electrically controlled, heating and cooling unit utilizing a(n) hermetic scroll compressor(s) for cooling duty and heat pump for heating duty.
- B. Factory assembled, single-piece heating and cooling rooftop unit. Contained within the unit enclosure shall be all factory wiring, piping, controls, and special features required prior to field start-up.
- C. Unit shall use environmentally safe, R-454B refrigerant.
- D. Unit shall be installed in accordance with the manufacturer’s instructions.
- E. Unit must be selected and installed in compliance with local, state, and federal codes.
- F. Model and serial data shall be printed inside the control box.

##### 1.01 Quality Assurance:

- A. Unit meets ASHRAE 90.1 2022 minimum efficiency requirements.
- B. Unit shall be rated in accordance with AHRI Standards 210/240 or 340/360 and 10 CFR appendix M1 to subpart B or part 430.
- C. Unit shall be designed to conform to ASHRAE 15.
- D. Unit shall be UL-tested and certified in accordance with Standards and UL-listed and certified under Canadian standards as a total package for safety requirements.
- E. Insulation and adhesive shall meet NFPA 90A requirements for flame spread and smoke generation.
- F. Unit casing shall be capable of withstanding 1000-hour salt spray exposure per ASTM B117 (scribed specimen).
- G. Roof curb shall be designed to conform to NRCA Standards.
- H. Unit shall be subjected to a completely automated run test on the assembly line. The data for each unit will be stored at the factory and must be available upon request.
- I. Unit shall be designed in accordance with UL Standard 60335-2-40 4th Edition. including tested to withstand rain.

##### 1.02 Manufacturer Qualifications

- A. Unit shall be designed in accordance with ISO 9001:2015 and shall be manufactured in a facility registered by ISO 9001:2015.

##### 1.03 Installer Qualifications

- A. The installer shall be trained to install and service equipment with A2L refrigerants.

##### 1.04 Delivery, Storage, and Handling:

- A. Unit shall be stored and handled per manufacturer’s recommendations.
- B. Lifted by crane requires either shipping top panel or spreader bars.
- C. Unit shall only be stored or positioned in the upright position.

##### 1.05 Unit Cabinet:

- A. Shall be constructed of galvanized steel.
- B. Exterior paint shall be: pre-painted steel.
- C. The sheet-metal cabinet shall be constructed of 18-gauge material for structural components with an underlying coat of G90.
- D. Evaporator fan compartment interior cabinet insulation shall conform to AHRI Standards 210/240 minimum exterior sweat criteria. Interior surfaces shall be insulated with a minimum 1/2-in. thick, 1.6 lb density, flexible fiberglass insulation, foil faced on the air side.
- E. Base of unit shall have a location for thru-the-base gas and electrical connections standard.
- F. Base Rail:
  - i. Unit shall have base rails on a minimum of 4 sides.
  - ii. Holes shall be provided in the base rails for rigging shackles to facilitate maneuvering and overhead rigging.
  - iii. Holes shall be provided in the base rail for moving the rooftop unit with a fork truck.
  - iv. Base rail shall be a minimum of 14 gauge thickness.

- G. Condensate pan and connections:
  - i. Shall be a sloped condensate drain pan made of a non-corrosive material and be removable for cleaning.
  - ii. Shall comply with ASHRAE Standard 62.
  - iii. Shall use a 3/4" NPT drain connection, possible either through the bottom or side of the drain pan. Connection shall be made per manufacturer's recommendations.
  - iv. Shall be able to be easily removed.
  - v. Shall be separate from the coil.
- H. Standard factory-installed condensate overflow sensor.
- I. Top panel
  - i. Shall be a single piece top panel over indoor section.
- J. Electrical Connections:
  - i. All unit power wiring may enter unit cabinet through a single, factory-prepared, continuous raised flange opening in the basepan. Unit power wiring may also enter unit cabinet through a dedicated entry point on the condenser side of the unit.
  - ii. Thru-the-base capability:
    - a. Standard unit shall have a thru-the-base electrical location(s) using a raised, continuous raised flange opening in the basepan.
    - b. No basepan penetration, other than those authorized by the manufacturer, is permitted.
- K. Component access panels (standard):
  - i. Cabinet panels shall be easily opened for servicing.
  - ii. Panels covering control box, indoor fan, indoor fan motor, gas components (where applicable), and filters shall have hinges with 1/4 turn fasteners on units with factory-installed hinged option.
  - iii. 1/4 fasteners shall be permanently attached.

**1.06 Operating Characteristics:**

- A. Unit shall be capable of starting and running at 115°F (46°C) ambient outdoor temperature, meeting maximum load criteria of AHRI Standard 210/240 or 340/360 at ± 10% voltage.
- B. Compressor with standard controls shall be capable of operation down to 50°F (10°C), ambient outdoor temperatures. Low ambient accessory kit is necessary if mechanically cooling at ambient temperatures to 30°F (-1.1°C).
- C. Unit shall discharge supply air vertically or horizontally as shown on contract drawings.
- D. Unit shall be factory configured for vertical supply & return configurations.
- E. Unit shall be field convertible from vertical to horizontal configuration.

**1.07 Electrical Requirements**

- A. Main power supply voltage, phase, and frequency must match those required by the manufacturer.

**1.08 Evaporator Fan Compartment:**

- A. Interior cabinet surfaces shall be insulated with a minimum 1/2-in. thick, minimum 1.6 lbs. density, flexible fiberglass insulation bonded with foil face on the air side.
- B. Insulation and adhesive shall meet NFPA 90A requirements for flame spread and smoke generation.
- C. Insulation shall also be mechanically fastened with welded pin and retainer washer.

**1.09 Thermostats:**

- A. Energize both "W" and "G" when calling for heat.
- B. Have capability to energize 1 stage of cooling, and at least 1 stage of heating.
- C. All units shall have the capability to energize to 2 stages.
- D. Include capability for occupancy scheduling.

**1.10 Electronic Control System for HVAC:**

- A. Shall be complete with self-contained low-voltage control circuit protected by a fuse on the 24-V transformer side.
- B. Shall utilize color-coded wiring.
- C. Shall include a central control terminal board to conveniently and safely provide connection points for vital control functions such as: smoke detectors, phase monitor, economizer, thermostat, building management systems, loss of charge, freeze sensor, high-pressure switches.
- D. Unit shall include a minimum of one 11-position terminal block for control wiring.
- E. Unit control board incorporates a 22 character LCD display to easily navigate through the Human Machine Interface (HMI) and with easy-to-understand fault codes for status and diagnostics.

**1.10.01 Safeties:**

- A. Compressor over-temperature, over current.
- B. Standard Low-pressure switch:
  - i. Units shall have low pressure, loss of charge automatic reset device that will shut off compressor when tripped.
  - ii. Low pressure control:  
Provides active protection in both heating and cooling modes at all outdoor ambient temperatures. The low pressure control is an automatic reset type and opens at approximately 15 PSIG and closes at approximately 40 PSIG. Operation is slightly different between cooling and heating modes.
- C. Standard High-pressure switch:
  - i. Unit shall be equipped with high pressure switch device that will shut off compressor when tripped.
  - ii. High pressure control:  
The high pressure control is an automatic reset type and opens at approximately 610 PSIG and closes at approximately 420 PSIG. The compressor and fan motor will stop when the high pressure control opens and will start again if the high side pressure drops to approximately 420 PSIG where the automatic reset high pressure control resets. If the high pressure control opens 3 times within a particular call for heating or cooling operation, the defrost control will lock out compressor and outdoor fan operation.
- D. Automatic reset, motor thermal overload protector.
- E. The unit must be permanently grounded.
- F. Components are not compatible between different refrigerants. Do not use R-410A service equipment or components on R-454B equipment. System or part failure could occur.
- G. Heating section shall be provided with the following minimum protections
  - i. High-temperature limit switches.

**1.11 Standard Filter Section:**

- A. Shall consist of factory-installed, low velocity, throwaway 2-in. thick fiberglass filters of commercially available sizes.
- B. Unit will accept both 2-in. and 4-in. filters.
- C. Filter face velocity shall not exceed 365 fpm at nominal airflows.
- D. Filters shall be accessible through an access panel with “no-tool” removal as described in the unit cabinet section of the specification.
- E. Filters access is specified in the unit cabinet section of this specification.
- F. Filters shall be held in place by metal rods, facilitating easy removal and installation.

**1.12 Coils**

- A. Standard Aluminum/MicroChannel Coils:
  - i. Standard evaporator and condenser coils shall be aluminum.
  - ii. Evaporator and condenser coils shall be leak tested to 150 PSIG, pressure tested to 400 PSIG, and qualified to burst test at 2,200 psi.

**1.13 Refrigerant Components:**

- A. Refrigerant circuit shall include the following control, safety, and maintenance features:
  - i. TXV metering system shall prevent mal-distribution of two-phase refrigerant.
  - ii. Refrigerant filter drier.
  - iii. Service gauge connections on suction and discharge lines.
  - iv. External pressure gauge ports access shall be located in front exterior of cabinet.
  - v. External gauge ports shall be lockable.
- B. Compressors:
  - i. Unit shall use one two-stage scroll compressor with internal line break overload and high pressure protection.
  - ii. Compressor motors shall be cooled by refrigerant gas passing through motor windings.
  - iii. Compressors shall be internally protected from high discharge temperature conditions.
  - iv. Compressors shall be protected from an over-temperature and over-amperage conditions by an internal, motor overload device.
  - v. Compressor shall be factory mounted on rubber grommets.
  - vi. Compressor motors shall have internal line break thermal and current overload protection.
  - vii. Crankcase heaters shall not be required for normal operating range.
  - viii. Compressor shall have molded electrical plug.

**1.14 Evaporator Fan and Motor:**

- A. Evaporator Fan Motor:
  - i. Shall have permanently lubricated bearings.
  - ii. Shall have inherent automatic-reset thermal overload protection.
- B. Direct Drive Evaporator Fan:
  - i. Direct drive ECM technology with multiple speed of 0-10Vdc(%) input from the controller.
  - ii. Blower fan shall be double-inlet type with forward-curved blades.
  - iii. Shall be constructed from steel with a corrosion resistant finish and dynamically balanced.
- C. Blower Assembly:
  - i. Entire assembly shall be able to slide out completely.
  - ii. Shall be able to slide-out without the removal of the roof and condenser fan motors.

**1.15 Condenser Fans and Motors:**

- A. Condenser Fan Motor:
  - i. Shall be a totally enclosed motor.
  - ii. Shall use permanently lubricated bearings.
  - iii. Shall have inherent thermal overload protection with an automatic reset feature.
  - iv. Shall use a shaft-down design. Shaft-up designs including those with “rain-slinger devices” shall not be allowed.
- B. Condenser Fan:
  - i. Shall be a direct-driven propeller type fan.
  - ii. Shall have blades riveted to corrosion-resistant steel spiders and shall be dynamically balanced.

**1.16 RTU-C Controller:**

- A. Shall be ASHRAE 62-2001 compliant.
- B. Shall accept 18-32VAC input power.
- C. Shall have an operating temperature range from -40°F (-40°C) to 140°F (60°C), 10%– 95% RH (non-condensing).
- D. Shall accept the following inputs: space temperature, setpoint adjustment, outdoor air temperature, indoor air quality, outdoor air enthalpy, compressor lock-out, fire shutdown, enthalpy switch and fan status/filter status/humidity/remote occupancy.
- E. Shall accept a CO<sub>2</sub> sensor in the conditioned space and be Demand Control Ventilation (DCV) ready.
- F. Shall provide the following outputs: Economizer, fan, cooling stage 1, cooling stage 2, electric heat stage 1, electric heat stage 2, heat pump heating stage 1, heat pump heating stage 2, exhaust, occupied.
- G. Unit shall provide surge protection for the controller through a circuit breaker.
- H. Shall have a built-in BACnet IP or MS/TP allowing the unit to be able to communicate at a an adjustable Baud rate.
- I. Shall have an LCD display independently showing the status of activity on the communication bus, and processor operation.
- J. Software upgrades will be accomplished by local download. Software upgrades through chip replacements are not allowed.
- K. Shall be shock resistant in all planes to 5G peak, 11ms during operation, and 100G peak, 11ms during storage.
- L. Shall be vibration resistant in all planes to 1.5G @ 20-300 Hz.
- M. Shall support a bus length of 4000 ft max, 60 devices per 1000 ft section, and 1 RS-485 repeater per 1000 ft sections.
- N. Shall allow access of up to 62 network variables (SNVT). Shall be compatible with all open controllers.
- O. Shall have an LED display independently showing the status of serial communication, running, errors, power, all digital outputs and all analog inputs.
- P. Shall accept the following inputs: space temperature, setpoint adjustment, outdoor air temperature, indoor air quality, outdoor air enthalpy, compressor lock-out, fire shutdown, enthalpy switch and fan status/filter status/humidity/remote occupancy.
- Q. Shall be natively equipped with Modbus® communication protocol.

**1.17 Special Features:**

- A. Integrated Economizers:
  - i. Integrated, parallel modulating blade design type capable of simultaneous economizer and compressor operation.
  - ii. Independent modules for vertical or horizontal return configurations shall be available. Vertical return modules shall be available as a factory-installed option.
  - iii. Damper blades shall be galvanized steel. Plastic or composite blades on intake or return shall not be acceptable.
  - iv. Shall include all hardware and controls to provide free cooling with outdoor air when temperature and/or humidity are below setpoints.

- v. Shall be equipped with driven dampers for both the outdoor ventilation air and the return air for positive air stream control.
  - vi. Shall be equipped with low-leakage dampers, not to exceed 2% leakage at 1-in. wg pressure differential.
  - vii. Shall be capable of introducing up to 100% outdoor air.
  - viii. Shall be equipped with a barometric relief damper capable of relieving up to 100% return air.
  - ix. Shall be designed to close damper(s) during loss-of-power situations with spring return built into motor.
  - x. Enthalpy sensor shall be provided as standard. Outdoor air sensor set point shall be adjustable and shall range from 40 to 100°F / 4 to 38°C. Additional sensor options shall be available as accessories.
  - xi. The economizer controller shall also provide control of an accessory power exhaust unit function. Factory set at 60%, with a range of 0% to 100%.
  - xii. The economizer shall maintain minimum airflow into the building during occupied period and provide design ventilation rate for full occupancy. A remote potentiometer may be used to override the damper set point.
  - xiii. Dampers shall be completely closed when the unit is in the unoccupied mode.
  - xiv. Economizer controller shall accept a 0-10VDC, 0-5VDC, 2-10VDC, or 4-20ma CO<sub>2</sub> sensor input for IAQ/DCV control.
  - xv. Actuator shall be direct coupled to economizer gear. No linkage arms or control rods shall be acceptable.
  - xvi. Economizer controller shall provide indications when in free cooling mode, in the DCV mode, or the exhaust fan contact is closed.
  - xvii. Economizer wire harness will have provision for smoke detector available in supply and return options.
  - xviii. Shall provide fault detection and diagnostics (FDD) system in accordance with local code.  
Faults shall be communicated out on an alarm signal.
- B. Manual Damper
- i. Manual damper package shall consist of damper, air inlet screen, and rain hood which can be preset to admit up to 50% outdoor air for year-round ventilation.
- C. Condenser Coil Hail Guard Assembly:
- i. Shall protect against damage from hail.
  - ii. Shall be louvered style.
- D. Unit-Mounted, Non-Fused Disconnect Switch:
- i. Switch shall be factory-installed, internally mounted.
  - ii. National Electric Code (NEC) and UL approved non-fused switch shall provide unit power shutoff.
  - iii. Shall be accessible from outside the unit.
  - iv. Shall provide local shutdown and lockout capability.
- E. Convenience Outlet:
- i. Non-Powered convenience outlet.
  - ii. Outlet shall be powered from a separate 115-120V power source.
  - iii. A transformer shall not be included.
  - iv. Outlet shall be field-installed and internally mounted with easily accessible 115V female receptacle.
  - v. Outlet shall include 15 amp GFI receptacle with independent fuse protection.
  - vi. Outlet shall be accessible from outside the unit.
- F. Propeller Power Exhaust:
- i. Power exhaust shall be used in conjunction with an integrated economizer.
  - ii. Independent modules for vertical or horizontal return configurations shall be available.
  - iii. Horizontal power exhaust shall be mounted in return ductwork.
  - iv. Power exhaust shall be controlled by economizer controller operation. Exhaust fans shall be energized when dampers open past the 0-100% adjustable setpoint on the economizer control.
  - v. Capable of adjustable but constant volume.
- G. Roof Curbs (Vertical):
- i. Formed galvanized steel with wood nailer strip and shall be capable of supporting entire unit weight.
  - ii. Permits installation and securing of ductwork to curb prior to mounting unit on the curb.
- H. Return Air Enthalpy Sensor
- i. The return air enthalpy sensor shall be used in conjunction with an outdoor air enthalpy sensor to provide differential enthalpy control.

- I. Indoor Air Quality (CO<sub>2</sub>) Sensor:
  - i. Shall be able to provide demand ventilation indoor air quality (IAQ) control.
  - ii. The IAQ sensor shall be available in duct mount, wall mount, or wall mount with LED display. The set point shall have adjustment capability.
- J. Smoke Detectors:
  - i. Shall be a Four-Wire Controller and Detector.
  - ii. Shall be environmental compensated with differential sensing for reliable, stable, and drift-free sensitivity.
  - iii. Shall use magnet-activated test/reset sensor switches.
  - iv. Shall have tool-less connection terminal access.
  - v. Shall have a recessed momentary switch for testing and resetting the detector.
  - vi. Controller shall include:
    - a. One set of normally open alarm initiation contacts for connection to an initiating device circuit on a fire alarm control panel.
    - b. Two Form-C auxiliary alarm relays for interface with rooftop unit or other equipment.
    - c. One Form-C supervision (trouble) relay to control the operation of the Trouble LED on a remote test/reset station.
    - d. Capable of direct connection to two individual detector modules.
    - e. Can be wired to up to 14 other duct smoke detectors for multiple fan shutdown applications.
- K. Barometric Relief:
  - i. Shall include damper, seals, hardware and hoods to relieve excess building pressure.
  - ii. Damper shall gravity-close upon shutdown.
- L. Time Guard:
  - i. Shall prevent compressor short cycling by providing a 5-minute delay ( $\pm 2$  minutes) before restarting a compressor after shutdown for any reason.
  - ii. One device shall be required per compressor.
- M. Standard Factory-Installed Overflow Switch
  - i. Switch shall monitor the condensate level in drain pan and stops compression operation when overflow conditions occur.
- M. Refrigerant Leak Detection System:
  - i. Shall be standard and factory-installed in every unit.
  - ii. Shall trigger a fault code to the unit controller and initiate mitigation procedures.



**GENERAL TERMS OF LIMITED WARRANTY\***

Ruud® will furnish a replacement for any part of this product which fails in normal use and service within the applicable periods stated, in accordance with the terms of the limited warranty.

**\*For complete details of the Limited and Conditional Warranties, including applicable terms and conditions, contact your local contractor or the Manufacturer for a copy of the product warranty certificate.**

**Compressor**  
 Commercial Applications .....Five (5) Years  
 Residential Applications.....Ten (10) Years

**Parts**  
 Commercial Applications .....One (1) Year  
 Residential Applications  
 (Registration Required) .....Ten (10) Years

**Before proceeding with installation, refer to installation instructions packaged with each model, as well as complying with all Federal, State, Provincial, and Local codes, regulations, and practices.**

© 2026 Rheem Manufacturing Company. Trademarks are property of their respective owners.

In keeping with its policy of continuous progress and product improvement, manufacturer reserves the right to make changes without notice.

5600 Old Greenwood Road  
 Fort Smith, Arkansas 72908 • Ruud.com

125 Edgeware Road, Unit 1  
 Brampton, Ontario • L6Y 0P5 • Ruud-canada.ca