



Vantix™ Line Gas Furnaces



S802V

80% A.F.U.E.†

EcoNet® Enabled

Heating Stages: Two-Stage

Motor Type: Constant CFM

Input Rates: Upflow/Horizontal: 50-150 kBTU [14.7-44.0 kW]

Configuration Options: Upflow/Horizontal



† A.F.U.E. (Annual Fuel Utilization Efficiency) calculated in accordance with Department of Energy test procedures.

The Bluetooth® word mark and logos are registered trademarks owned by Bluetooth SIG, Inc. and any use of such marks by Rheem® is under license. Other trademarks and trade names are those of their respective owners.

Table of Contents

Features & Benefits	3
Model Number Identification	4
Physical Data and Specifications	5
Dimensional Data	6-7
Blower Performance Data	8
Accessories	9-10
Limited Warranty	12

Features and Benefits

- **Diagnostics:** With the Russell® By Rheem Contractor & EcoNet® Apps, built-in EcoNet® & Bluetooth®¹ technology makes monitoring, troubleshooting and repairing the product easier than ever before
- **Dip Switch Free Installation Commissioning via Bluetooth® Technology:** Seamless final install step without DIP switch configuration using the Russell® By Rheem Contractor App
- **Ignition System:** Proven Direct Spark Ignition (DSI) for reliability and longevity
- **Two-Stage Heating:** Furnace operation mainly stays at low capacity around 60-65%, but will switch to high capacity to deliver stable heat distribution
- **Constant CFM Motor:** Truly variable speed technology allows for ultimate humidity control, quieter sound levels and year-round energy savings
- **Quieter Operation²:** A fully insulated blower cabinet, solid bottom and truly variable speed airflow technology makes this furnace one of the quieter options available
- **EcoNet® Enabled Furnace:** The latest in sensor technology and the EcoNet® monitoring system provides a new level of protection, control and energy savings
- **Allows on-the-go control** and receipt of system alerts by the homeowner via the EcoNet® Smart Thermostat and EcoNet® App³

¹The Bluetooth® word mark and logos are registered trademarks owned by Bluetooth SIG, Inc. and any use of such marks by Rheem® is under license. Other trademarks and trade names are those of their respective owners.

²Based on manufacturer's furnace offering, and the product's heating stages, motor type and cabinet insulation. Sound levels are also dependent on furnace location and installation.

³Wifi broadband internet connection required. Download the EcoNet® App from the App Store® or Google Play® to set up your EcoNet® Smart Thermostat. Receipt of notifications depend on home WiFi set up. Amazon, Alexa and all related logos are trademarks of Amazon.com, Inc. or its affiliates.

Gas Furnaces

<u>S</u>	<u>80</u>	<u>2</u>	<u>V</u>	<u>050</u>	<u>3</u>	<u>A</u>	<u>14</u>	<u>UH</u>	<u>S</u>	<u>B</u>	<u>A</u>	<u>P</u>
Brand	Furnace Efficiency	Stages of Heating	Motor Type	Heating Input	AC Max. Capacity	Major Series	Width	Position	NOx	Controls	Minor Series	Option Code
S - Russell® By Rheem	80 - 80% AFUE	2 - Two-Stage	V - ECM Variable Speed	050 - 50,000 [14.7 kW] 075 - 75,000 [22.0 kW] 100 - 100,000 [29.3 kW] 125 - 125,000 [36.6 kW] 150 - 150,000 [44.0 kW]	3 - 3 ton drive 4 - 4 ton drive 5 - 5 ton drive	A - 1st Design Series	14 - 14" Width 17 - 17.5" Width 21 - 21" Width 24 - 24.5" Width	UH - Upflow Horizontal	S - Standard N - Low NOx	B - Communicating, EcoNet®, Bluetooth®	A - 1st Series	P - Premium Grade

[] Designates Metric Conversions

AVAILABLE MODELS
S802V0503A14UH*BAP
S802V0504A17UH*BAP
S802V0754A17UH*BAP
S802V0755A21UH*BAP
S802V1004A17UH*BAP
S802V1005A21UH*BAP
S802V1255A24UH*BAP
S802V1505A24UH*BAP

* S = Standard, N = Low NOx

STANDARD EQUIPMENT	
**Adjustable Humidifier On/Off Delay	Fully Insulated Heat Exchanger Cabinet
**Auxiliary Input Connection	Humidifier Connections
**Condensate Switch Connection	Humidistat Terminal Connection
**Outdoor Air Temperature Sensor Connection	Limit Controls
**Supply Air Sensor Connection	Low Speed Continuous Fan Option
100% Safety Lock Out	Manual Shut-Off Valve
2 Stage Induced Draft Motor	On Demand Dehumidifier Connection
Adjustable Cool Fan Off Delay	One Hour Automatic Retry
Adjustable Humidifier On/Off Delay(EcoNet®/App Only)	Power and Self-Test Diagnostics
Aluminized Steel Heat Exchanger Design	Pressure Switches
Blower Compartment Door Safety Switch	PWM Controlled Variable Speed Electrically Commutated Blower Motor
Bluetooth® Diagnostics	Redundant 2 Stage Main Gas Control
Bluetooth® Setup	Single Speed Option for Heating and Cooling Applications
Completely Assembled and Wired	Solid Bottom
Direct Drive Motor	Blower Insulation
EcoNet® Thermostat Connections	Two Plus* Stage Cooling Thermostat Connection
Electronic Air Cleaner Connections	Two Speed Heating
Electronic On/Off Blower Time Control	

NOTE: A thermostat is not included as standard equipment
 *When Connected to Three Speed or Modulating AC/HP Product
 **EcoNet® Only Features

WARNING
 THIS FURNACE IS NOT APPROVED
 OR RECOMMENDED
 FOR USE IN MOBILE HOMES

Physical Data and Specifications—Upflow Models

MODEL NUMBERS S802V 2 stg VS UP/HZ SERIES	S802V0503 A14UH*BAP	S802V0504 A17UH*BAP	S802V0754 A17UH*BAP	S802V0755 A21UH*BAP	S802V1004 A17UH*BAP	S802V1005 A21UH*BAP	S802V1255 A24UH*BAP	S802V1505 A24UH*BAP
Input-BTU/Hr [kW]	50,000 [15]	50,000 [15]	75,000 [22]	75,000 [22]	100,000 [29]	100,000 [29]	125,000 [37]	150,000 [44]
Heating Capacity BTU/Hr [kW] ①	40,000 [12]	40,000 [12]	60,000 [18]	60,000 [18]	80,000 [23]	80,000 [23]	100,000 [29]	120,000 [35]
Low Input BTU/Hr	35,000 [10]	35,000 [10]	52,000 [15]	52,000 [15]	70,000 [21]	70,000 [21]	87,500 [26]	105,000 [31]
Low Heating Capacity BTU/Hr	28,000 [8]	28,000 [8]	42,000 [12]	42,000 [12]	56,000 [16]	56,000 [16]	70,000 [21]	84,000 [25]
Blower (D x W) [mm]	11 x 6 [279 x 152]	11 x 7 [279 x 178]	11 x 7 [279 x 178]	11 x 7 [279 x 178]	11 x 7 [279 x 178]	11 x 10 [279 x 254]	11 x 10 [279 x 254]	11 x 10 [279 x 254]
Motor H.P. [W] Type	1/2 [373] VS-CT(ECM)	3/4 [560] VS-CT(ECM)	3/4 [560] VS-CT(ECM)	1 [746] VS-CT(ECM)	3/4 [560] VS-CT(ECM)	3/4 [560] VS-CT(ECM)	3/4 [560] VS-CT(ECM)	1 [746] VS-CT(ECM)
Min. Circuit Ampacity	9	13	9	15	12	12	12	16
Min. Overload Protection Device	15	15	15	15	20	15	15	20
Max. Overload Protection Device	15	20	20	20	25	20	20	25
Motor Full Load Amps	6.1	9.6	9.6	12.4	9.6	9.6	9.6	12.4
High Heating CFM [L/s]	960 [453]	930 [439]	1450 [684]	1425 [673]	1425 [673]	1380 [651]	1900 [897]	1680 [793]
Low Heating CFM [L/s]	750 [354]	775 [366]	1150 [543]	1100 [519]	1225 [578]	1200 [566]	1400 [661]	1500 [708]
MAX Cooling CFM [L/s]	1240 [585]	1650 [779]	1650 [779]	1980 [934]	1650 [779]	1980 [934]	1980 [934]	1980 [934]
MIN Cooling CFM [L/s]	300 [142]	500 [236]	500 [236]	500 [236]	500 [236]	500 [236]	500 [236]	500 [236]
Fan CFM [L/s]	600 [283]	800 [378]	800 [378]	1000 [472]	800 [378]	1000 [472]	1000 [472]	1000 [472]
Max. E.S.P. (In. W.C.) [kPa]	1.0 [0.25]	1.0 [0.25]	1.0 [0.25]	1.0 [0.25]	1.0 [0.25]	1.0 [0.25]	1.0 [0.25]	1.0 [0.25]
Temperature Rise Range °F – High Input	25-55 [13.9-30.6]	25-55 [13.9-30.6]	25-55 [13.9-30.6]	25-55 [13.9-30.6]	35-65 [19.4-36.1]	35-65 [19.4-36.1]	35-65 [19.4-36.1]	45-75 [25-41.7]
Temperature Rise Range °F – Low Input	20-50 [11.1-27.8]	20-50 [11.1-27.8]	20-50 [11.1-27.8]	20-50 [11.1-27.8]	25-55 [13.9-30.6]	25-55 [13.9-30.6]	30-60 [16.7-33.3]	35-65 [19.4-36.1]
Approx. Shipping Weight (Lbs.) [kg]	104.5 [47]	110 [50]	117.5 [53]	135 [61]	131.5 [60]	140 [64]	143.5 [65]	155.5 [71]
AFUE ②	80.0%	80.0%	80.0%	80.0%	80.0%	80.0%	80.0%	80.0%

NOTES: All models are 115V, 60HZ, 1 Ph. Gas connection size for all models is 1/2" [13 mm] N.P.T.

① In accordance with D.O.E. test procedures.

② See Conversion Kit Index Form for high altitude derate.

*S=Standard, N=Low NOx

This furnace does not meet air district requirements of 14 ng/J NOx emissions limit, and thus is subject to a mitigation fee of up to \$450.

This furnace is to be installed for propane firing only in air districts requiring 14 ng/J NOx emission limits. Operating in natural gas mode is in violation of these Rules.

[] Designates Metric Conversions

Upflow Application

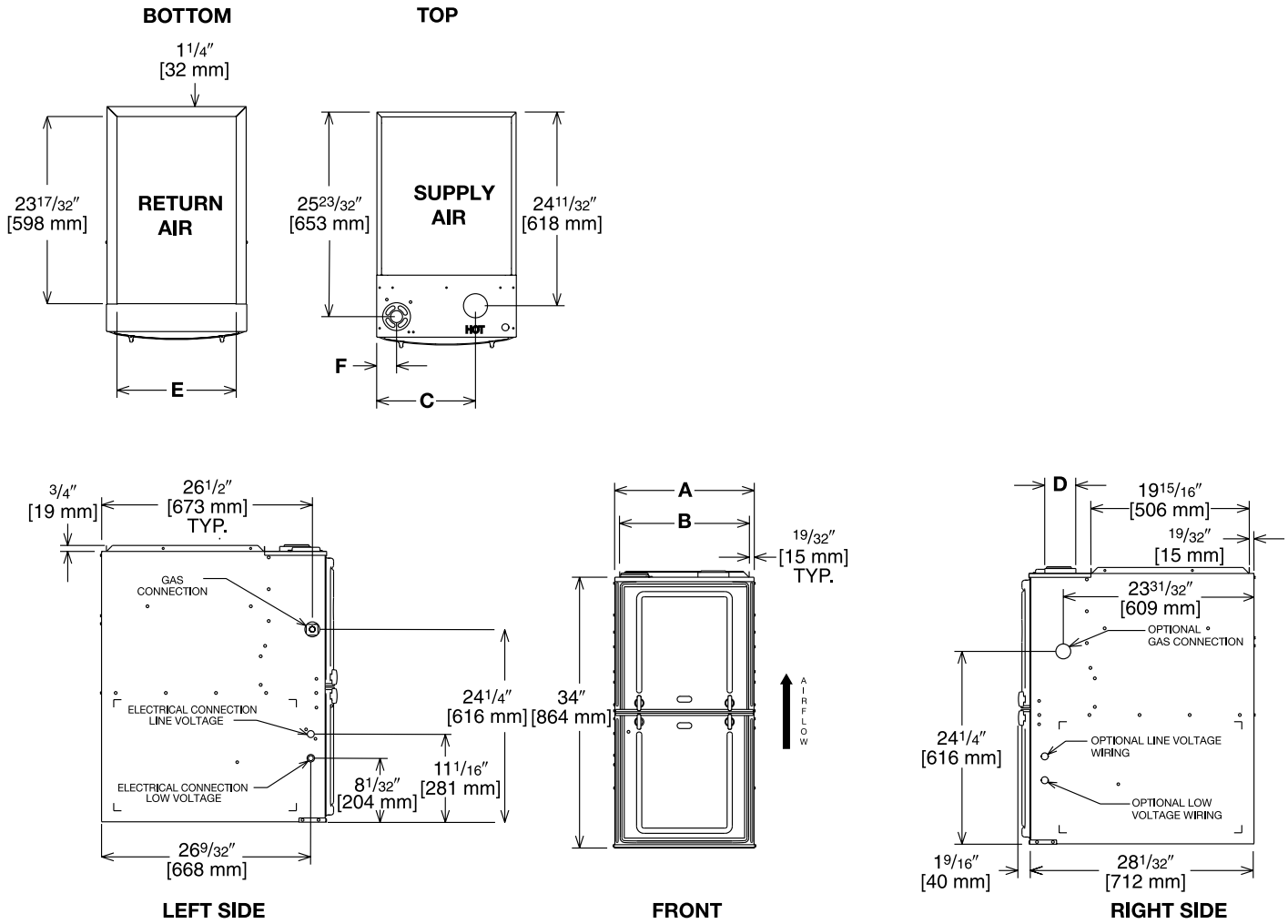

Illustration
ST-A1220-04-00
FIGURE 1

Dimensional Data: Upflow Model

MODEL S802V-	A	B	C	D	E	F	MINIMUM CLEARANCE (IN.) [mm]					
							SUPPLY AIR SIDE	RETURN AIR SIDE	BACK	TOP	FRONT	VENT
050314	14 [356]	12 27/32 [326]	10 5/8 [270]	①	11 1/2 [292]	17/8 [48]	4 [102] ②	4 [102] ②	0	1 [25]	3 [76]	6 [152] ③
050417/75417	17 1/2 [445]	16 11/32 [415]	12 3/8 [314]	①	15 [381]	2 1/2 [64]	3 [76] ②	3 [76] ②	0	1 [25]	3 [76]	6 [152] ③
075521/100	21 [533]	19 27/32 [504]	14 1/8 [359]	①	18 1/2 [470]	2 1/2 [64]	0	0	0	1 [25]	3 [76]	6 [152] ③
125	24 1/2 [622]	23 11/32 [592]	15 7/8 [403]	①	22 [559]	2 1/2 [64]	0	0	0	1 [25]	3 [76]	6 [152] ③

NOTES: ① May require a 3" [76 mm] to 4" [102 mm] or 3" [76 mm] to 5" [127 mm] adapter.

② May be 0" [0 mm] with type B vent.

③ May be 1" [25 mm] with type B vent.

Furnaces must be vented in accordance with the National Fuel Gas Code, ANSI Z223.1 and in accordance with local codes.

[] Designates Metric Conversions

Horizontal Application

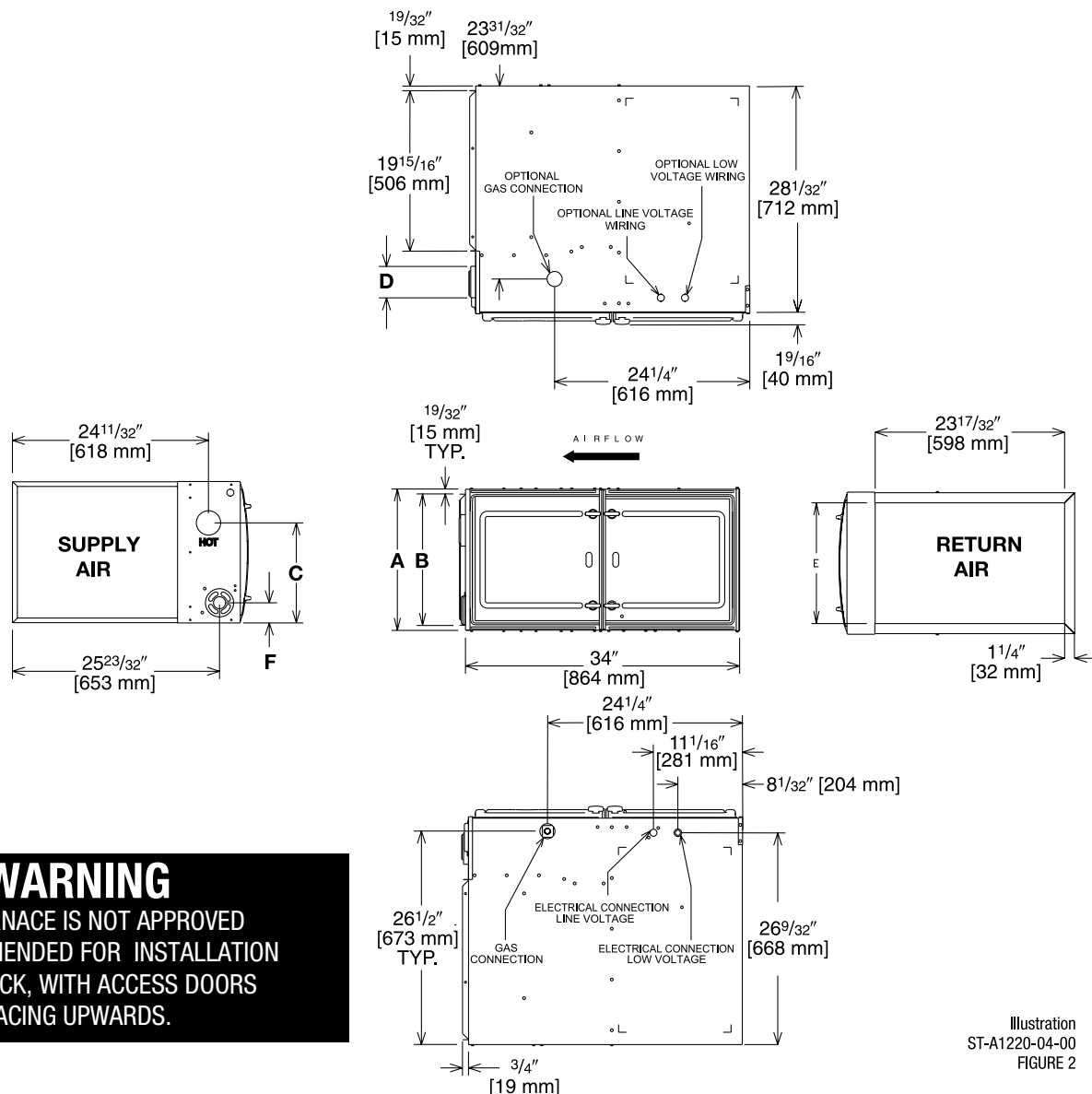

WARNING
THIS FURNACE IS NOT APPROVED
OR RECOMMENDED FOR INSTALLATION
ON ITS BACK, WITH ACCESS DOORS
FACING UPWARDS.

Illustration
ST-A1220-04-00
FIGURE 2

Dimensional Data: Horizontal Model

MODEL S802V-	A	B	C	D	E	F	MINIMUM CLEARANCE (IN.) [mm]					
							SUPPLY AIR SIDE	RETURN AIR SIDE	BACK	TOP	FRONT	VENT
050314	14 [356]	1227/32 [326]	10 ⁵ / ₈ [270]	①	11 1/2 [292]	17/8 [48]	4 [102] ②	4 [102] ②	0	1 [25]	3 [76]	6 [152] ③
050417/75417	17 1/2 [445]	16 11/32 [415]	12 ³ / ₈ [314]	①	15 [381]	2 1/2 [64]	3 [76] ②	3 [76] ②	0	1 [25]	3 [76]	6 [152] ③
075521/100	21 [533]	1927/32 [504]	14 1/8 [359]	①	18 1/2 [470]	2 1/2 [64]	0	0	0	1 [25]	3 [76]	6 [152] ③
125	24 1/2 [622]	23 11/32 [592]	15 7/8 [403]	①	22 [559]	2 1/2 [64]	0	0	0	1 [25]	3 [76]	6 [152] ③

NOTES: ① May require a 3" [76 mm] to 4" [102 mm] or 3" [76 mm] to 5" [127 mm] adapter.

② May be 0" [0 mm] with type B vent.

③ May be 1" [25 mm] with type B vent.

Furnaces must be vented in accordance with the National Fuel Gas Code, ANSI Z223.1 and in accordance with local codes.

[] Designates Metric Conversions

Blower Performance Data

TARGET GAS HEATING AIRFLOWS								
	S802V0503 A14UH*BAP	S802V0504 A17UH*BAP	S802V0754 A17UH*BAP	S802V0755 A21UH*BAP	S802V1004 A17UH*BAP	S802V1005 A21UH*BAP	S802V1255 A24UH*BAP	S802V1505 A24UH*BAP
Factory Low Heating CFM [L/s]	750 [354]	775 [366]	1150 [543]	1100 [519]	1225 [578]	1200 [566]	1400 [661]	1500 [708]
Low Heat Side Return CFM [L/s]	750 [354]	745 [352]	1100 [519]	1150 [543]	1260 [595]	1242 [586]	1480 [698]	1650 [779]
Low Heat Approx. ±7°F CFM [L/s]	660 [311]	698 [329]	1035 [488]	990 [467]	1078 [509]	1086 [513]	1260 [595]	1320 [623]
Low Heat Approx. ±12°F CFM [L/s]	608 [287]	644 [303]	955 [451]	913 [431]	993 [469]	996 [470]	1162 [548]	1215 [573]
Factory High Heating CFM [L/s]	960 [453]	930 [439]	1450 [684]	1425 [673]	1425 [673]	1380 [651]	1900 [897]	1680 [793]
High Heat Side Return CFM [L/s]	960 [453]	930 [439]	1450 [684]	1425 [673]	1539 [726]	1380 [651]	1900 [897]	1815 [857]
High Heat Approx. ±7°F CFM [L/s]	864 [408]	837 [395]	1305 [616]	1283 [506]	1283 [606]	1245 [588]	1710 [807]	1512 [714]
High Heat Approx. ±12°F CFM [L/s]	797 [376]	772 [364]	1204 [568]	1183 [558]	1183 [558]	1146 [541]	1577 [744]	1394 [658]

* S = Standard, N = Low NOx

[] Designates Metric Conversions

SIDE RETURN FILTER RACK: RXGF-CD
BOTTOM RETURN FILTER RACK FOR
UPFLOW APPLICATION: RXGF-CB

FILTER RACK FILTER SIZES* INCHES		
MODEL	RXGF-CB (UPFLOW/ HORIZONTAL)	RXGF-CD (UPFLOW) SIDE RETURN
S802V050	12 ¹ / ₄ x 25	15 ³ / ₄ x 25
S802V075/ S802V0755A21	15 ³ / ₄ x 25	15 ³ / ₄ x 25
S802V1004A1	19 ¹ / ₄ x 25	15 ³ / ₄ x 25
S802V125	22 ³ / ₄ x 25	15 ³ / ₄ x 25
S802V150	22 ³ / ₄ x 25	15 ³ / ₄ x 25

Indoor Coil Casings

MODEL NUMBER
RXBC-D14AI
RXBC-D17AI
RXBC-D21AI
RXBC-D21BI
RXBC-D24AI

4" FLUE ADAPTER: RXGW-C01

WARNING: IMPORTANT NOTICE

A SOLID METAL BASE PLATE (SEE TABLE) MUST BE IN PLACE WHEN THE FURNACE IS INSTALLED WITH SIDE AIR RETURN DUCTS. FAILURE TO INSTALL A BASE PLATE COULD CAUSE PRODUCTS OF COMBUSTION TO BE CIRCULATED INTO THE LIVING SPACE AND CREATE POTENTIALLY HAZARDOUS CONDITIONS.

FURNACE WIDTH IN.	SOLID BOTTOM KIT NO.	BASE PLATE NO.	BASE PLATE SIZE IN.
14	RXGB-D14	AE-61874-01	11 ⁵ / ₈ x 23 ⁹ / ₁₆
17 ¹ / ₂	RXGB-D17	AE-61874-02	15 ¹ / ₈ x 23 ⁹ / ₁₆
21	RXGB-D21	AE-61874-03	18 ⁵ / ₈ x 23 ⁹ / ₁₆
24 ¹ / ₂	RXGB-D24	AE-61874-04	25 ⁵ / ₈ x 23 ⁹ / ₁₆

For High Altitudes:

OPTION CODE FOR HIGH ALTITUDE: U.S.

None required for high altitudes.

HIGH ALTITUDE CONVERSION KITS: U.S.

None required for high altitudes.

80+ HIGH ALTITUDE INSTRUCTIONS

CAUTION: Always follow National Fuel Gas Code (NFGC) guidelines when converting for high altitudes.

High altitude option codes are not required for these models. However, the burner orifice size needs to be recalculated and verified at elevations above 2000 ft. See Installation Instructions for more information.

L.P. CONVERSION KIT: RXGJ-FP32

Integrated Controls



EcoNet® is smart, technology that allows Heating and Cooling, products to communicate with each other on one integrated network.

THE ECONET® SMART THERMOSTAT

BUILT-IN WIFI

4.3" LCD TOUCH SCREEN

LOCAL WEATHER – Current conditions plus 6-day forecast

5 OPERATING MODES – Heat, Cool, Auto, Emergency Heat and Fan Only

7-DAY PROGRAMMABLE SCHEDULE – Offers comfort without thought

ONE-TOUCH AWAY – Quickly switch to your energy-saving away preferences

VACATION SCHEDULING – Allows you to save while you're away and come home to comfort

STANDBY SCREEN – Displays indoor temperature and current weather



CETST800SYS

OPERATIONAL FEATURES

AUTOMATIC CHANGEOVER – Transitions between heating and cooling automatically to keep the house comfortable

INTEGRATED WATER CONTROL – Enables easy water heater management

SMOOTH ARRIVAL – Prompts the system to start ahead of schedule to ensure the home is at the desired temperature at the scheduled time

HUMIDITY CONTROL – Supports humidifier accessories or over-cool based dehumidification

DETAILED OPERATING STATUS – View pertinent equipment status information and run times

CONTINUOUS FAN – Offers 5 speeds (Low, Medium Low, Medium, Medium High, High)

SHORT-CYCLE PROTECTION – Avoids damage to equipment from short run cycles

MONITORING & REMOTE CONTROL FEATURES

ACTIVE MONITORING – Alerts to problems that need immediate attention

REMOTE CONTROL – Allows adjusting of comfort and settings from anywhere using a mobile device

SERVICE ALERTS – Sends routine maintenance reminders

AIR FILTER MONITORING – Detects when it's time to replace the air filter

ALARM HISTORY – Displays time-stamped alarm codes with clear descriptions



GENERAL TERMS OF LIMITED WARRANTY*

Russell® By Rheem will furnish a replacement for any part of this product which fails in normal use and service within the applicable period stated, in accordance with the terms of the limited warranty.

Conditional Parts
(Registration Required)..... Ten (10) Years
Heat Exchanger Limited Lifetime

***For complete details of the Limited and Conditional Warranties, including applicable terms and conditions, contact your local contractor or the Manufacturer for a copy of the product warranty certificate.**

Before proceeding with installation, refer to installation instructions packaged with each model, as well as complying with all Federal, State, Provincial, and Local codes, regulations, and practices.

© 2024 Rheem Manufacturing Company. Russell By Rheem trademarks owned by Rheem Manufacturing Company.
In keeping with its policy of continuous progress and product improvement, Russell by Rheem reserves the right to make changes without notice.

5600 Old Greenwood Road
Fort Smith, Arkansas 72908 • www.russellbyrheem.com