



MODEL: S801T Upflow/Horizontal Gas Furnaces

FORM NO. GRR-544 REV. 1



Russell™ By Rheem S801T Upflow/Horizontal Gas Furnaces

- **Models with Input Rates from 50 to 125 kBTU**



"Proper sizing and installation of equipment is critical to achieve optimal performance. Split system air conditioners and heat pumps must be matched with appropriate coil components to meet Energy Star. Ask your Contractor for details or visit www.energystar.gov."

- **80% Residential Gas Furnace** CSA certified
- **3 Way Multi Poise** design UF / HZ
- **7 Segment LED** all units
- **Direct Spark Ignition** for reliability and longevity
- **Removable Heat Exchanger** for improved serviceability. Aluminized steel construction provides maximum corrosion resistance and thermal fatigue reliability
- **Solid Doors** provide quiet operation
- **Solid Bottom**
- **Insulated Blower Compartment**
- **Low Profile 34" Cabinet** ideal for space constrained installations

- **Blower Shelf Design** – serviceable in all furnace orientations
- **Hemmed Edges** on cabinets and doors
- **1/4 Turn Door Knobs** for tool less access
- **Integrated Control Board** features dip switches for easy system set up
- **QR Code** for quick access to product information from your smart phone or tablet
- **Constant Torque** electrically commutated motor
- **Cabinet Air Leakage Less Than 2%** at 1 inch H₂O when tested in accordance with ASHRAE standard 193

TABLE OF CONTENTS

Standard & Optional Equipment	3
Model Features/Physical Data & Specifications	4
Model Number Identification	5
Dimensional Data	6-7
Blower Performance Data	8
Accessories	9
Limited Warranty	10

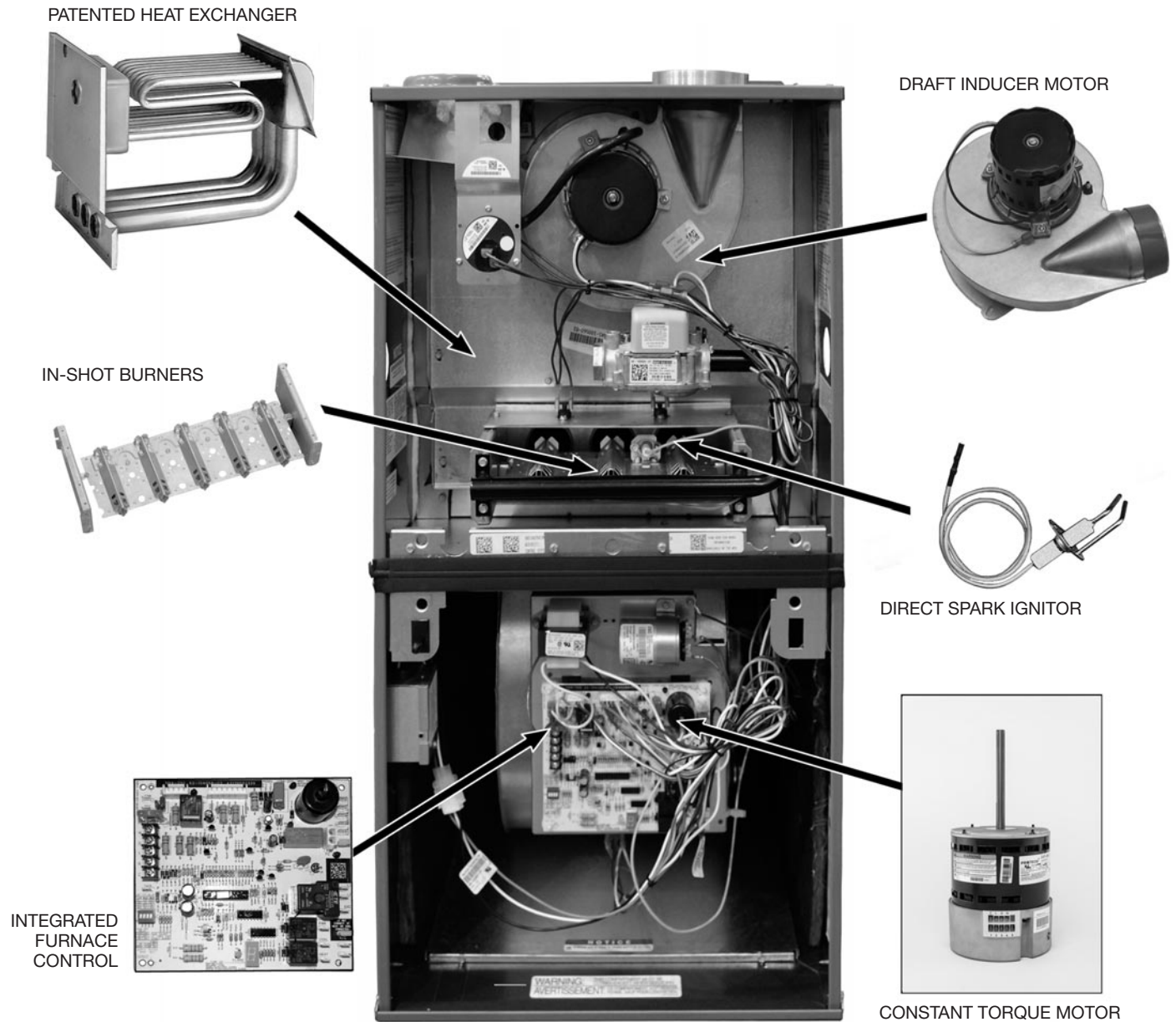

STANDARD EQUIPMENT

Completely assembled and wired; induced draft; pressure switch; redundant main gas control; blower compartment door safety switch; solid state time on/time off blower control; limit control; manual shut-off valve, pressure regulator for natural and L.P. (propane) gas; transformer; direct drive multi-speed blower motor. Furnaces are equipped with cooling/heating relay and transformer (40VA) ready for air conditioning applications. (Please note: a thermostat is not included as standard equipment.) Flame sensor diagnostics.

OPTIONAL EQUIPMENT

Side and bottom filter frame assembly. Return air cabinet for all sizes.
 NOTE: Furnace is not listed for use with fuels other than natural or L.P. (propane) gas.
 The complete terms of limited and other warranties are available at our sales office, or through local installer.
 All models can be converted by a qualified Russell™ By Rheem distributor or local service dealer to use L.P. (propane) gas without changing burners. Factory approved kits must be used to convert from natural to L.P. (propane) gas and may be ordered as optional accessories from a Russell™ By Rheem parts distributor.
 For L.P. (propane) operation, refer to Conversion Kit Index Form.
 NOTE: For natural and L.P. (propane) gas models, direct spark ignition is 100% safety lockout type.

WARNING
 THIS FURNACE IS NOT APPROVED
 OR RECOMMENDED
 FOR USE IN MOBILE HOMES

Model Features

- 80% residential Gas Furnace CSA certified
- 3 way multi poise design UF / HZ
- 7 Segment LED all units
- Direct Spark Ignition for reliability and longevity
- Heat exchanger is removable for improved serviceability. Aluminized steel construction provides maximum corrosion resistance and thermal fatigue reliability.
- Solid doors provide quiet operation
- Solid bottom
- Insulated blower compartment
- Low profile 34" cabinet ideal for space constrained installations
- Blower shelf design serviceable in all furnace orientations
- Hemmed edges on cabinets and doors
- 1/4 turn door knobs for tool less access
- Integrated Controls board features dip switches for easy system set up
- QR code for quick access to product information from your smart phone or tablet
- Constant Torque electrically commutated motor

Physical Data and Specifications

MODEL NUMBERS S801T SERIES	S801TA050314M*A	S801TA075417M*A	S801TA075421M*A	S801TA100521M*A	S801TA125524M*A
Input-BTU/Hr [kW] ②	50,000 [15]	75,000 [22]	75,000 [22]	100,000 [29]	125,000 [37]
Heating Capacity BTU/Hr [kW] ①	40,000 [12]	60,000 [18]	60,000 [18]	80,000 [23]	100,000 [29]
Heat Ext. Static Pressure [kPa]	.18 [.05]	.20 [.05]	.20 [.05]	.28 [.07]	.28 [.07]
Blower (D x W) [mm]	11 x 6 [279 x 152]	11 x 7 [279 x 178]	11 x 7 [279 x 178]	11 x 10 [279 x 254]	11 x 10 [279 x 254]
Motor H.P.–Speed–PSC Type [W]	1/2-5 Spd Constant Torque [373]	1/2-5 Spd Constant Torque [373]	3/4-5 Spd Constant Torque [560]	3/4-5 Spd Constant Torque [560]	3/4-5 Spd Constant Torque [560]
Min. Circuit Ampacity	8	8	9	10	11
Min. Overload Protection Device	15	15	15	15	15
Max. Overload Protection Device	15	15	15	15	15
Heating Speed	Med-Low	Med	Med	Med-Low	Med
Cooling Speed	High	High	High	High	High
Cooling CFM @ Rating Point [L/s]	1305 [616]	1402 [662]	1608 [759]	1840 [868]	1934 [913]
Max. E.S.P. (In. W.C.) [kPa]	0.9 [.22]	0.9 [.22]	0.9 [.22]	0.9 [.22]	0.9 [.22]
Temperature Rise Range °F [°C]	25-55 [13.9-30.6]	25-55 [13.9-30.6]	25-55 [13.9-30.6]	35-65 [19.4-36.1]	35-65 [19.4-36.1]
Max. Outlet Air Temp. °F [°C]	155 [68.3]	155 [68.3]	160 [71.1]	180 [82.2]	165 [73.8]
Approx. Shipping Weight (Lbs.) [kg]	110 [50]	125 [57]	140 [64]	140 [64]	150 [68]
AFUE ①	80.0%	80.0%	80.0%	80.0%	80.0%

NOTES: All models are 115V, 60HZ, 1 Ph. Gas connection size for all models is 1/2" [12 mm] N.P.T.

① In accordance with D.O.E. test procedures.

② See Conversion Kit Index Form for high altitude derate.

③ R801SA075317 wired for 2 tons AC.

* S = Standard, X = Low Nox

This furnace does not meet air district requirements of 14 ng/J NOx emissions limit, and thus is subject to a mitigation fee of up to \$450. This furnace is not eligible for the Clean Air Furnace Rebate Program: www.CleanAirFurnaceRebate.com.

This furnace is to be installed for propane firing only in air districts requiring 14 ng/J NOx emission limits. Operating in natural gas mode is in violation of these Rules.

[] Designates Metric Conversions

Model Number Identification

<u>S</u>	<u>80</u>	<u>1</u>	<u>T</u>	<u>A</u>	<u>075</u>	<u>4</u>	<u>17</u>	<u>M</u>	<u>S</u>	<u>A</u>
Russell™ By Rheem	80 = 80% AFUE	1 = Single Stage	T = Constant Torque	Design Series A = 1st Design	Input BTU/HR [kW]	3 = Up to 3 Ton	Cabinet Width	M = Multi	X = Low NO _x S = Standard	Revision- Marketing (A – First Time Release)
					050 = 50,000 [15]	4 = Up to 4 Ton	14 = 14"			
					075 = 75,000 [22]	5 = Up to 5 Ton	17 = 17.5"			
					100 = 100,000 [29]		21 = 21"			
					125 = 125,000 [37]		24 = 24.5"			

[] Designates Metric Conversions

Upflow Application

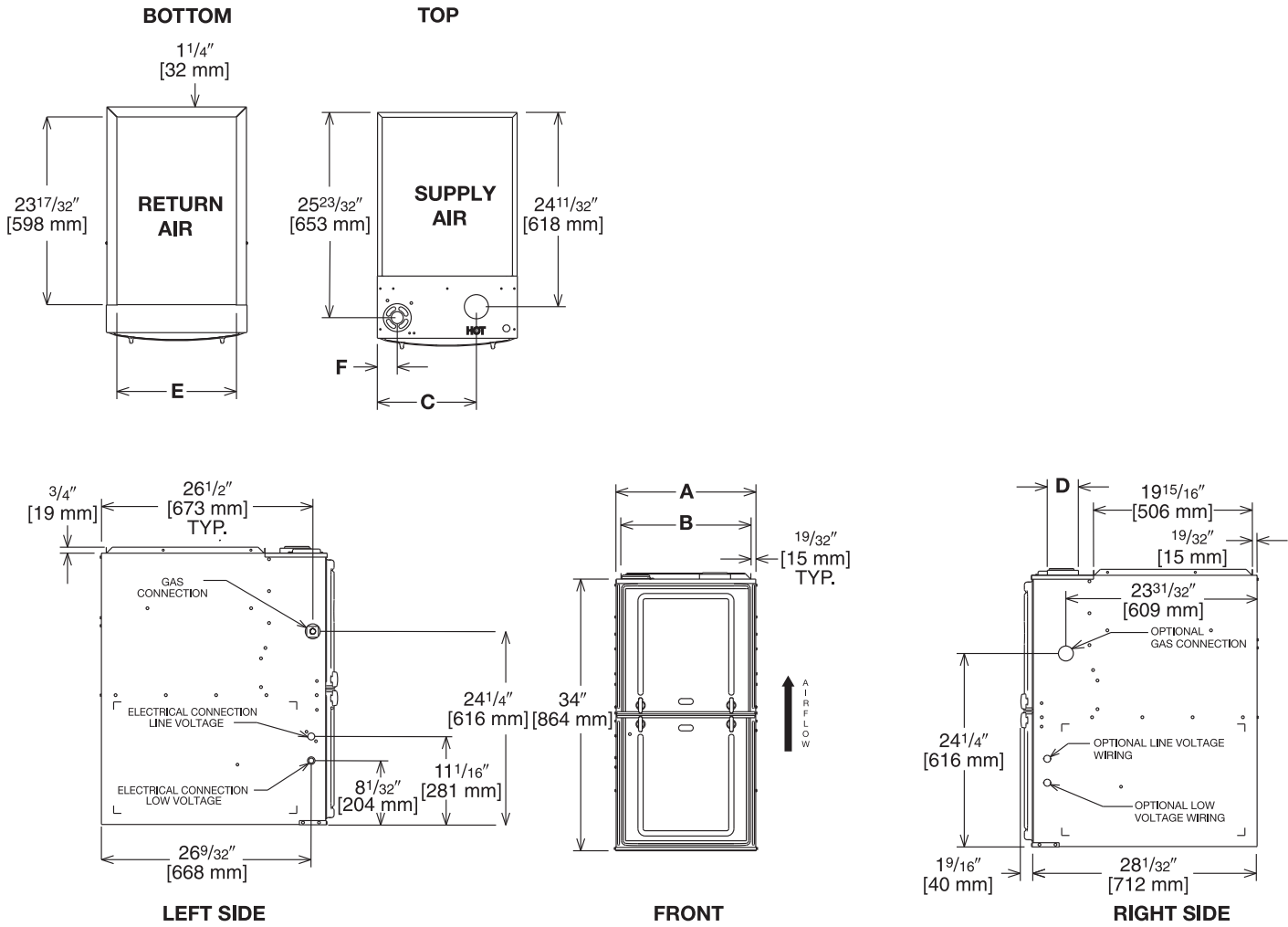

Illustration
 ST-A1220-04-00
 FIGURE 1

Dimensional Data: Upflow Model

MODEL S801T-	A	B	C	D	E	F	MINIMUM CLEARANCE (IN.) [mm]					SHIP WGTS. (LBS.) [kg]	
							SUPPLY AIR SIDE	RETURN AIR SIDE	BACK	TOP	FRONT		VENT
050	14 [356]	12 27/32 [326]	10 5/8 [270]	①	11 1/2 [292]	17/8 [48]	0	4 [102] ②	0	1 [25]	3 [76]	6 [152] ③	110 [50]
075	17 1/2 [445]	16 11/32 [415]	12 3/8 [314]	①	15 [381]	2 1/2 [64]	0	3 [76] ②	0	1 [25]	3 [76]	6 [152] ③	125 [57]
100	21 [533]	19 27/32 [504]	14 1/8 [359]	①	18 1/2 [470]	2 1/2 [64]	0	0	0	1 [25]	3 [76]	6 [152] ③	140 [64]
125	24 1/2 [622]	23 11/32 [593]	15 7/8 [403]	①	22 [559]	2 1/2 [64]	0	0	0	1 [25]	3 [76]	6 [152] ③	150 [68]

NOTES: ① May require a 3" [76 mm] to 4" [102 mm] or 3" [76 mm] to 5" [127 mm] adapter. 4" adapter included with (-)801P units.

② May be 0" [0 mm] with type B vent.

③ May be 1" [25 mm] with type B vent.

Furnaces must be vented in accordance with the National Fuel Gas Code, ANSI Z223.1 and in accordance with local codes.

[] Designates Metric Conversions

Horizontal Application

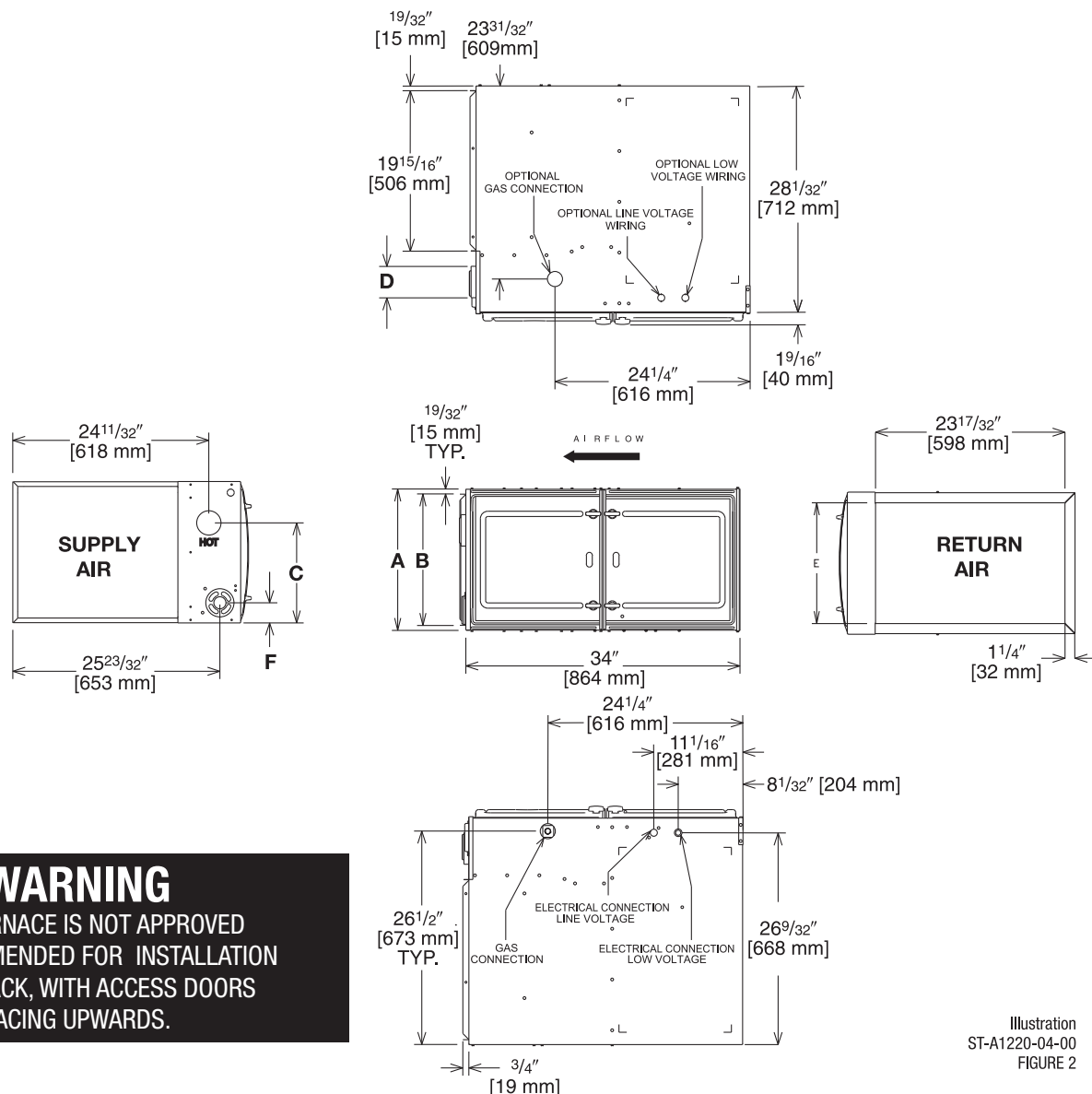

WARNING
 THIS FURNACE IS NOT APPROVED
 OR RECOMMENDED FOR INSTALLATION
 ON ITS BACK, WITH ACCESS DOORS
 FACING UPWARDS.

Illustration
 ST-A1220-04-00
 FIGURE 2

Dimensional Data: Horizontal Model

MODEL S801T-	A	B	C	D	E	F	MINIMUM CLEARANCE (IN.) [mm]						SHIP WGTS. (LBS.) [kg]
							SUPPLY AIR SIDE	RETURN AIR SIDE	BACK	TOP	FRONT	VENT	
050	14 [356]	12 ²⁷ / ₃₂ [326]	10 ⁵ / ₈ [270]	①	11 ¹ / ₂ [292]	1 ⁷ / ₈ [48]	0	4 [102] ②	0	1 [25]	3 [76]	6 [152] ③	110 [50]
075	17 ¹ / ₂ [445]	16 ¹¹ / ₃₂ [415]	12 ³ / ₈ [314]	①	15 [381]	2 ¹ / ₂ [64]	0	3 [76] ②	0	1 [25]	3 [76]	6 [152] ③	125 [57]
100	21 [533]	19 ²⁷ / ₃₂ [504]	14 ¹ / ₈ [359]	①	18 ¹ / ₂ [470]	2 ¹ / ₂ [64]	0	0	0	1 [25]	3 [76]	6 [152] ③	140 [64]
125	24 ¹ / ₂ [622]	23 ¹¹ / ₃₂ [593]	15 ⁷ / ₈ [403]	①	22 [559]	2 ¹ / ₂ [64]	0	0	0	1 [25]	3 [76]	6 [152] ③	150 [68]

NOTES: ① May require a 3" [76 mm] to 4" [102 mm] or 3" [76 mm] to 5" [127 mm] adapter.

② May be 0" [0 mm] with type B vent.

③ May be 1" [25 mm] with type B vent.

Furnaces must be vented in accordance with the National Fuel Gas Code, ANSI Z223.1 and in accordance with local codes.

[] Designates Metric Conversions

Blower Performance Data

AIR FLOW PERFORMANCE - (-)801T (Upflow) SERIES MODELS											
MODEL	MOTOR H.P. [W] BLOWER SIZE IN [mm]	SPEED TAP	CFM [L/s] AIR DELIVERY EXTERNAL STATIC PRESSURE INCHES WATER COLUMN [kPa]								
			0.1 [.02]	0.2 [.05]	0.3 [.07]	0.4 [.10]	0.5 [.12]	0.6 [.15]	0.7 [.17]	0.8 [.19]	0.9 [.22]
			(-)801TA050314MSA	1/2 [373] 11 x 6 [279 x 152]	LOW	894	775	655	595	533	496
MED. LOW	971	912			875	839	804	758	713	684	644
MEDIUM	1117	1081			1051	1024	995	973	938	908	878
MED. HIGH	1326	1291			1275	1240	1204	1171	1144	1114	1077
HIGH	1440	1432			1405	1382	1353	1322	1305	1272	1251
(-)801TA075417MSA	1/2 [373] 11 x 7 [279 x 178]	LOW	1054	1014	964	911	860	797	711	657	606
		MED. LOW	1363	1318	1275	1230	1189	1129	1091	1053	1012
		MEDIUM	1447	1417	1366	1329	1288	1250	1215	1176	1137
		MED. HIGH	1553	1521	1478	1444	1407	1372	1332	1259	1264
		HIGH	1616	1574	1547	1508	1478	1438	1402	1375	1341
(-)801TA075421MSA	3/4 [559] 11 x 7 [279 x 178]	LOW	1176	1133	1095	1048	1000	951	908	861	810
		MED. LOW	1353	1312	1267	1236	1186	1149	1106	1079	1016
		MEDIUM	1400	1346	1307	1276	1225	1181	1145	1103	1069
		MED. HIGH	1568	1537	1498	1468	1433	1399	1353	1320	1287
		HIGH	1785	1775	1736	1704	1673	1629	1608	1573	1550
(-)801TA100521MSA	3/4 [559] 11 x 10 [279 x 254]	LOW	1277	1211	1164	1103	1035	967	861	800	740
		MED. LOW	1556	1498	1456	1409	1353	1308	1254	1198	1125
		MEDIUM	1644	1597	1554	1511	1463	1400	1358	1304	1253
		MED. HIGH	1879	1842	1785	1729	1692	1674	1621	1579	1537
		HIGH	2071	2025	1992	1948	1902	1872	1840	1795	1750
(-)801TA125524MSA	3/4 [559] 11 x 10 [279 x 254]	LOW	1398	1338	1278	1232	1177	1130	1041	975	909
		MED. LOW	1593	1546	1495	1454	1414	1342	1304	1251	1190
		MEDIUM	1878	1844	1807	1753	1714	1675	1634	1578	1536
		MED. HIGH	2025	1967	1931	1886	1856	1812	1748	1721	1668
		HIGH	2165	2124	2082	2047	2012	1973	1934	1894	1859

Note: Bold data is factory heating tap.
Table represents blower performance data WITHOUT filters.

[] Designates Metric Conversions

BOTTOM RETURN FILTER RACK FOR UPFLOW APPLICATION: RXGF-CB

SIDE RETURN FILTER RACK: RXGF-CD

FILTER RACK FILTER SIZES* INCHES [mm]		
MODEL	RXGF-CB (UPFLOW/HORIZONTAL)	RXGF-CD (UPFLOW) SIDE RETURN
S801TA050	12 ¹ / ₄ x 25 [311 x 635]	15 ³ / ₄ x 25 [400 x 635]
S801TA075417	15 ³ / ₄ x 25 [400 x 635]	15 ³ / ₄ x 25 [400 x 635]
S801TA075421/ S801TA100	19 ¹ / ₄ x 25 [489 x 635]	15 ³ / ₄ x 25 [400 x 635]
S801TA125	22 ³ / ₄ x 25 [578 x 635]	15 ³ / ₄ x 25 [400 x 635]

4" FLUE ADAPTER: RXGW-C01

INDOOR COIL CASINGS

MODEL NUMBER
RXBC-D14AI
RXBC-D17AI
RXBC-D21AI
RXBC-D21BI
RXBC-D24AI

WARNING: IMPORTANT NOTICE

A SOLID METAL BASE PLATE (SEE TABLE) MUST BE IN PLACE WHEN THE FURNACE IS INSTALLED WITH SIDE AIR RETURN DUCTS. FAILURE TO INSTALL A BASE PLATE COULD CAUSE PRODUCTS OF COMBUSTION TO BE CIRCULATED INTO THE LIVING SPACE AND CREATE POTENTIALLY HAZARDOUS CONDITIONS.

FURNACE WIDTH IN. [mm]	SOLID BOTTOM KIT NO.	BASE PLATE NO.	BASE PLATE SIZE IN. [mm]
14 [356]	RXGB-D14	AE-61874-01	11 ⁵ / ₈ x 23 ⁹ / ₁₆ [295 x 598]
17 ¹ / ₂ [445]	RXGB-D17	AE-61874-02	15 ¹ / ₈ x 23 ⁹ / ₁₆ [384 x 598]
21 [533]	RXGB-D21	AE-61874-03	18 ⁵ / ₈ x 23 ⁹ / ₁₆ [473 x 598]
24 ¹ / ₂ [622]	RXGB-D24	AE-61874-04	25 ⁵ / ₈ x 23 ⁹ / ₁₆ [651 x 598]

FOR HIGH ALTITUDES:

OPTION CODE FOR HIGH ALTITUDE: U.S.

None required for high altitudes.

HIGH ALTITUDE CONVERSION KITS: U.S.

None required for high altitudes.

80+ HIGH ALTITUDE INSTRUCTIONS

CAUTION: Always follow National Fuel Gas Code (NFGC) guidelines when converting for high altitudes.

High altitude option codes are not required for these models. However, the burner orifice size needs to be recalculated and verified at elevations above 2000 ft. See Installation Instructions for more information.

[] Designates Metric Conversions

GENERAL TERMS OF LIMITED WARRANTY*

Rheem® will furnish a replacement for any part of this product which fails in normal use and service within the applicable period stated, in accordance with the terms of the limited warranty.

Parts*Five (5) Years
Heat Exchanger.....Ten (10) Years

*For complete details of the Limited and Conditional Warranties, including applicable terms and conditions, contact your local contractor or the Manufacturer for a copy of the product warranty certificate.



Russell™ By Rheem

5600 Old Greenwood Road, Fort Smith, AR 72908

Before proceeding with installation, refer to installation instructions packaged with each model, as well as complying with all Federal, State, Provincial, and Local codes, regulations, and practices.