

PERFORMANCE PLATINUM™



The new degree of comfort®

PERFORMANCE PLATINUM™ Plug-in Heat Pump Water Heater with HydroBoost (120V Shared Circuit)

Efficiency

- Up to 3.46 UEF reduces operating cost
- ENERGY STAR® certified
- Title 24 Compliant (JA13 Ready)

Performance

- Delivers hot water more efficiently than most standard electric water heaters
- Ambient operating range: 37-145°F is widest in class, offering more days of HP operation annually; designed to meet Northern Climate Spec (NEEA Tier 2)²
- Integrated HydroBoost mixing valve maximizes output performance

Easy Installation

- Easy access side connections
- Factory installed plug-in power cord – plugs directly into a standard wall outlet
- Easily replaces a standard gas water heater

Integration

- Demand Response Ready – Built-in EcoPort (CTA-2045 Port) allows easy connection to Utility programs
- LED Screen with built-in water sensor alert with audible alarm¹
- Integrated EcoNet® Wi-Fi-connected² technology and free mobile app gives users control over water heater, allowing for customizable temperature, vacation settings, scheduling, energy savings and system monitoring at home or away
- LeakGuard™ and LeakSense™ Ready – Easily add leak detection and prevention with leak sensor and shut-off valve upgrade kit

Operation Modes

- Heat Pump
- Vacation/Away: 2-28 days (or placed on hold indefinitely)

Plus...

- Premium grade anode rod extends the life of the tank
- 3/4" NPT water inlet and outlet; 3/4" condensate drain connections
- Easy access, top mounted washable air filter
- 2" Non-CFC foam insulation
- Enhanced flow brass drain valve
- Temperature and pressure relief valve installed
- Design certified to NSF/ANSI 372 (Lead Content)

Warranty

- 10-Year limited tank and parts warranty
- See Residential Warranty Certificate for complete information

Units meet or exceed ANSI requirements and have been tested according to D.O.E. procedures. Units meet or exceed the energy efficiency requirements of NAECA, ASHRAE standard 90, ICC Code and all state energy efficiency performance criteria.



Shared Circuit Design

Plug-in Heat Pump with HydroBoost (120V Shared Circuit)

40, 50, 65 and 80-Gallon
Capacities
120 Volt / 1 PH
Electric



These products meet a stringent set of our internally defined sustainability standards.



LEED Points = 3

¹Available with select models. ² Wi-Fi broadband internet connection required.

See specifications chart on back.



The new degree of comfort.

Plug-in Heat Pump with HydroBoost (120V Shared Circuit) Specifications

PERFORMANCE PLATINUM™

Fuel Type	Desc.	Nominal Gallon Cap.	Rated Gallon Cap.	Model Number	Electric Breaker Size (Minimum) ¹	Average Electrical Wattage	Uniform Energy Factor (UEF)	Compressor BTU/h	First Hr. Rating		Recovery in G.P.H. 90° F Rise	Tank Height A	Diam. B	Ht. to Cold Inlet & Drain Valve	Ht. to Hot Outlet & T&P	Unit Wt. (LBS.)	Approx. Ship Wt. (LBS.)
									Tank Set Point Temp. (Degrees °F)	Gallons							
15 AMPS																	
Electric	Tall	40	36	XE40T10HM00U0	15	440W	2.8	4200	140	45	12	63"	20-1/4"	3-5/8"	39-5/8"	157	194
Electric	Tall	50	46	XE50T10HM00U0	15	440W	3.0	4200	140	55	12	62"	22-1/4"	3-5/8"	39-5/8"	178	218
Electric	Tall	65	59	XE65T10HM00U0	15	395W	3.33	4200	128	63	12	65"	24-1/4"	3-7/8"	42-3/8"	225	262
Electric	Tall	80	72	XE80T10HM00U0	15	395W	3.46	4200	132	84	12	75"	24-1/4"	3-7/8"	42-3/8"	244	281

Uniform Energy Factor and rated gallon capacity based on Department of Energy (DOE) requirements. All units have integrated Wi-Fi control board.

¹In cases of fused protection, a time delay fused protection will be required.

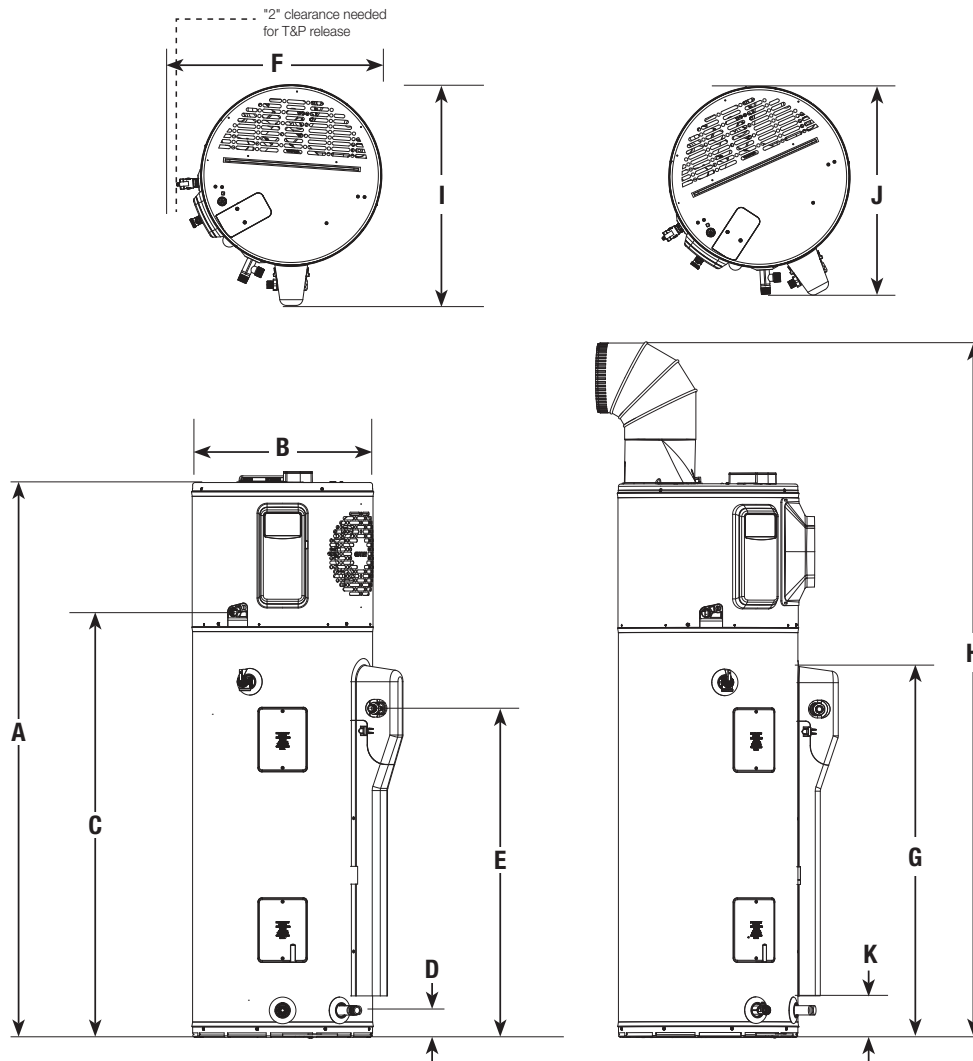

DESCRIPTION		DIMENSIONS (SHOWN IN INCHES)										
NOMINAL GALLON CAPACITY	MODEL NUMBER	A	B	C	D	E	F	G	H	I	J	K
40	XE40T10HM00U0	62-5/16	20-1/4	47	3-5/8	39-5/8	25-3/8	41-7/8	78-7/8	25	23-9/16	4-11/16
50	XE50T10HM00U0	61-3/4	22-1/4	47	3-5/8	39-5/8	27-3/8	41-1/2	78-5/8	27-3/8	25-9/16	4-5/16
65	XE65T10HM00U0	64-3/16	24-1/4	49	3-7/8	42-3/8	29-1/2	44-1-16	81-1/8	29	27-9/16	5
80	XE80T10HM00U0	74-3/16	24-1/4	59	3-7/8	42-3/8	29-1/2	54-5-16	91	29	27-9/16	5-1/16

Plug-in Heat Pump with HydroBoost Water Heater Installation Guidelines to Provide Optimal Efficiency

Heater: Not Ducted

Room size: Larger than 700 ft³ (e.g. 7' x 10' x 10').

Requirements:
No additional ventilation needed

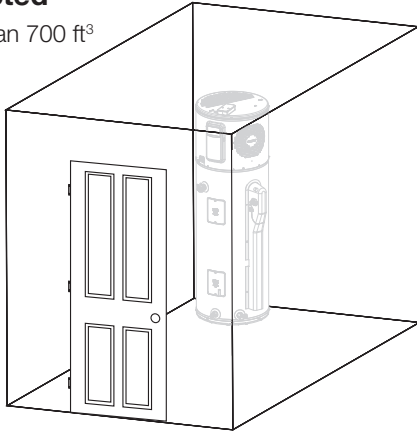

Heater: Not Ducted

Room size: Smaller than 700 ft³ (e.g. 7' x 10' x 10').

Requirements:
Full louvered door OR two louvers top and bottom. See to right.

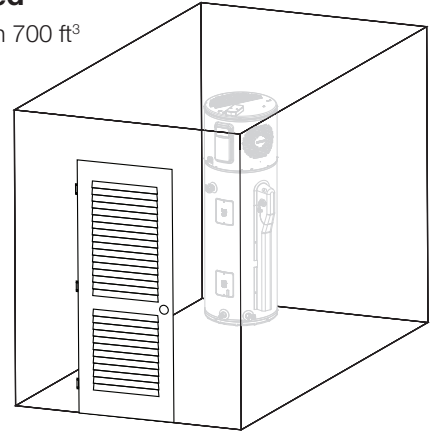

Heater: Ducted With Inlet or Outlet Duct

Room size:
Any size room

Requirements: Air gap under door equal to 18 in² (0.75" clearance)

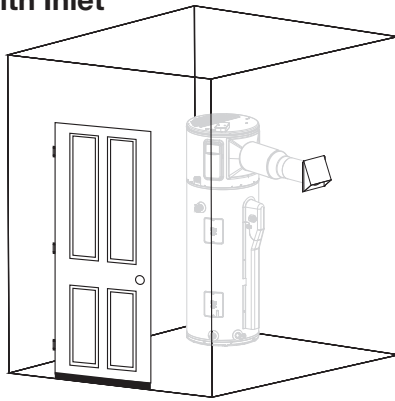

Heater: Ducted With Inlet and Outlet Duct

Room size:
Any size room

Requirements:
No additional ventilation needed

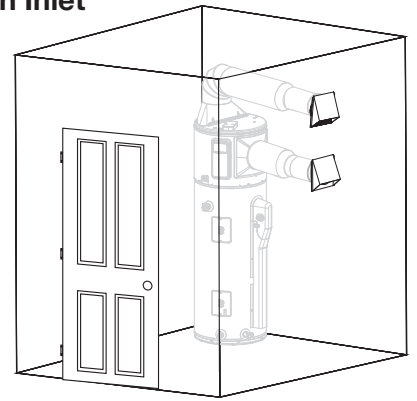

Notice

If air temperature in installed location drops more than 15°F (8°C) during heating, air circulation is insufficient for efficient operation. Utilize ducting to direct cold exhaust air to another location

For optimal operation, installation in gray US map zone is recommended. When choosing the proper water heater, consult your local plumbing contractor.

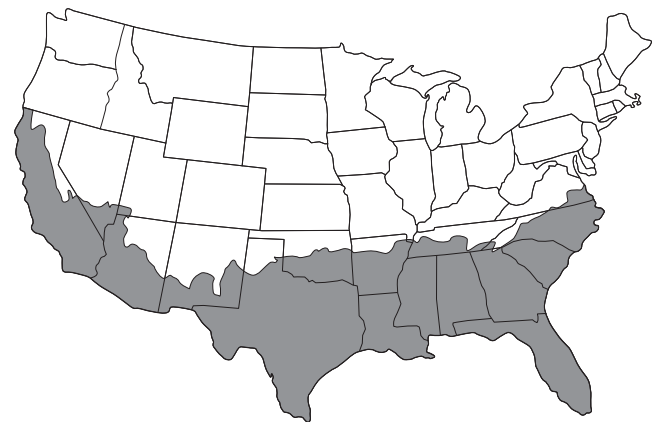
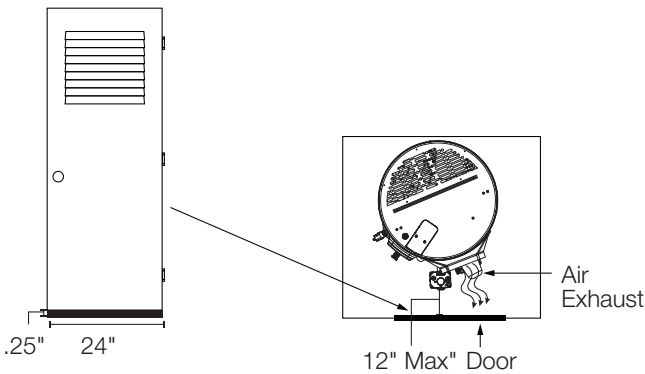

Average Ambient Air Temp in January

- Below 37°F
- Above 37°F

Heater: Not Ducted

Room size: Small Closet

Requirements:

- Air gap under door equals to 18 in² (0.75" clearance).
- Louver must be located the same height on door as the air exhaust on heater.
- Heater air exhaust must be positioned towards louver within one foot of door.

MINIMUM CLEARANCES (WITHOUT DUCTING)		
REAR	SIDES	TOP
0"	0"	6"



The new degree of comfort.

Plug-in Heat Pump with HydroBoost Service Parts and Accessories List

PART NUMBER	DESCRIPTION	USE FOR
AP19134	Leak Sensor	Automatic detection of internal and external leaks
AP20180	Shutoff Valve	Automatic shut off of water supply to unit
AP21365	Inlet Duct Adapter	Allows for ducting to be connected on the top inlet
AP17829	Outlet Duct Adapter	Allows for ducting to be connected to the unit
SP20882	Earthquake Isolation Kit	Installations in seismic regions
SP20883	Vibration Isolation Kit	Installation on non-concrete floors
SP20884	8" Diameter UL Certified Termination Kit	Termination to the outside or to the attic with 8" diameter
SP20885	7" Diameter UL Certified Termination Kit	Termination to the outside or to the attic with 7" diameter
SP20886	6" Diameter UL Certified Termination Kit	Termination to the outside or to the attic with 6" diameter
SP20887	5" Diameter UL Certified Termination Kit	Termination to the outside or to the attic with 5" diameter
SP20888	8" Rheem Approved Damper Kit	Exhaust only to the outside ducting configuration (no inlet duct)
SP21105	Inlet 25' Flexible 8" Diameter Duct Kit	For up to 25' of ducting
SP17829	Outlet 25' Flexible 8" Diameter Duct Kit	For up to 25' of ducting
SP20890	Rigid Elbow Duct Kit	Installation in tight places where space needs to be minimized
SP21111	Leak Sensor & Shutoff Valve Kit	Upgrade models to protect home from water damage with leak detection and auto shutoff valve

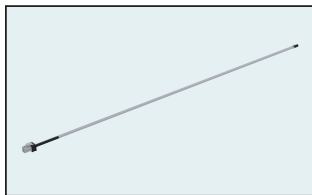

AP19134



AP20180

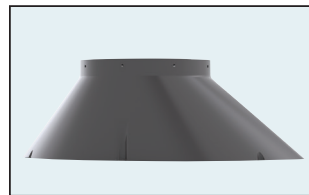

AP21365

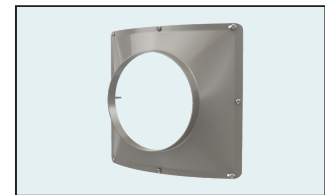

AP17829

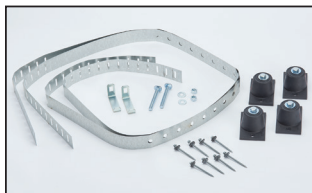

SP20882



SP20883



SP20884



SP20885



SP20886



SP20887



SP20888



SP21105 / SP17829



SP20890

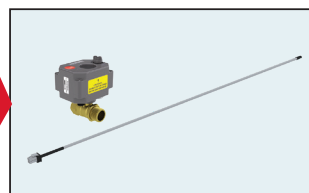
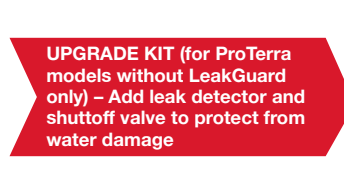

SP21111

In keeping with its policy of continuous progress and product improvement, Rheem reserves the right to make changes without notice.