

Important Safety Information

READ the Safety Information

Before inspecting, diagnosing, repairing or operating any water heater, be sure to examine all of the safety and warning labels on the water heater. Follow the instruction on these warning labels. Read and understand the Use and Care Manual that was shipped with the water heater. Failure to do so can result in unsafe operation of the water heater resulting in property damage, bodily injury, or death. Should you have any problems reading or following the instructions in the Use and Care Manual, seek the help of a licensed and qualified professional.

ELECTRICAL SHOCK

Troubleshooting and repairing this water heater can expose you to electrical shock. Some of the diagnostic procedures require the presence of AC and DC volt electricity. Use extreme caution when performing these procedures. When replacing an unserviceable component, turn off all power to the water heater and check for the presence of power with a multi-meter or test lamp. The ignition cable carries more than 10,000 volts of electrical energy. Use extreme caution when diagnosing the Tankless Gas Water Heater.

FLAMMABLE LIQUIDS AND VAPORS

Gasoline, as well as other flammable material and liquids (adhesives, solvents, etc.), and vapors they produce are extremely dangerous. DO NOT handle, use or store gasoline or other flammable or combustible materials anywhere near or in the vicinity of a water heater. The spark ignition and burner assembly in the water heater controls can ignite these vapors. Failure to do so can result in property damage, bodily injury or death.



WATER TEMPERATURE ADJUSTMENT

Safety and energy conservation are factors to be considered when selecting the water temperature setting on the thermostat. Water temperatures above 125° F can cause severe burns or death from scalding. The chart shown here may be used as a guide in determining the proper water temperature for your application.

TIME / TEMPERATURE RELATIONSHIPS IN SCALDS

| Temperature | Time to Produce Serious Burn |
|--|------------------------------|
| 120° F (49°C) | More than 5 minutes |
| 125° F (52°C) | 1½ to 2 minutes |
| 130° F (54°C) | About 30 seconds |
| 135° F (57°C) | About 10 seconds |
| 140° F (60°C) | Less than 5 seconds |
| 145° F (63°C) | Less than 3 seconds |
| 150° F (66°C) | About 1½ seconds |
| 155° F (68°C) | About 1 second |
| <small>Table courtesy of Shriners Burn Institute</small> | |

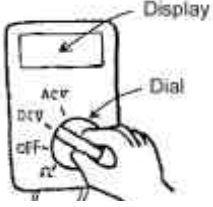
Troubleshooting Tools

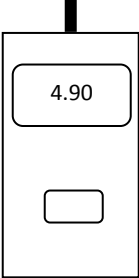
| | |
|---|--|
| <p>Multi-Meter Used to measure Resistance & Voltage</p> |  <p>A hand is shown turning the dial of a multi-meter. The dial has settings for 'ACV', 'DCV', 'OFF', and 'Ω'. The display shows a reading.</p> |
| <p>Multi-Meter Needle Set Used on meter test leads to access connectors while measuring Resistance & Voltage</p> |  <p>Two multi-meter needle sets are shown, one above the other.</p> |
| <p>Manometer Used to measure gas pressure during standby and operation</p> |  <p>A vertical manometer is shown with a reading of 4.90 on its scale.</p> |

SAFETY FIRST

Your safety and safety of others is very important. This manual is only intended for qualified service technicians. ALWAYS USE CAUTION while testing voltages and/or gas supply.

MEASURING VOLTAGE & RESISTANCE

WARNING: WHILE MEASURING VOLTAGE, DO NOT cross/touch multi-meter leads together. This will cause damage to electrical components.

WHEN INSERTING LEADS INTO WIRING CONNECTOR, insert on the wiring side to prevent damage to connector.

BEFORE MEASURING RESISTANCE, TURN OFF all electrical power and make sure to REMOVE CONNECTOR from the circuit (control board). Check resistance on connector that was removed.

WHEN MEASURING VOLTAGE, DO NOT REMOVE CONNECTOR; insert multi-meter leads prior to operating unit.

WHEN MEASURING DC VOLTAGE, if the meter displays the dash (---) symbol, swap the position of your black and red leads on the connector.

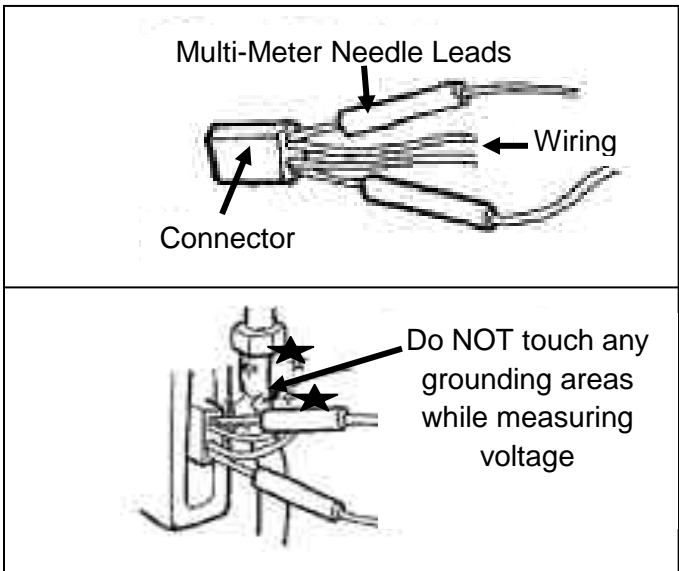

TABLE OF CONTENTS

General Information

| | |
|--|----|
| Installation Guidelines..... | 8 |
| Mid & High-Efficiency Flow Rates..... | 12 |
| Control Board Connectors..... | 14 |
| Diagnostic Points (Voltage & Resistance Readings)..... | 16 |
| Maintenance Mode Instructions..... | 21 |
| Altitude Settings on Control Board..... | 25 |
| Reset Procedures..... | 26 |
| Clearing Fault History..... | 27 |

Error Code Diagnostics

| | |
|-----------------------------------|----|
| No Error Code & No Hot Water..... | 28 |
| P1 Warning Code..... | 31 |
| 1L Warning Code..... | 32 |
| 03 Error Code..... | 34 |
| 05 Warning Code..... | 35 |
| 10 Warning Code..... | 37 |
| 11 Error Code..... | 40 |
| 12 Error Code..... | 46 |
| 13 Error Code..... | 48 |
| 14 Error Code..... | 50 |
| 15 Error Code..... | 52 |
| 16 Error Code..... | 53 |
| 24 Error Code..... | 54 |
| 29 Error Code | |
| High-Efficiency ONLY (A)..... | 55 |
| Mid & High-Efficiency (B)..... | 56 |
| 31 Error Code..... | 58 |
| 32 Error Code..... | 60 |
| 33 Error Code..... | 62 |
| 34 Error Code..... | 64 |
| 35 Error Code..... | 66 |
| 51 Error Code..... | 67 |
| 52 Error Code..... | 70 |

61 Error Code..... 73
65 Error Code..... 76
66 Error Code..... 78
71 Error Code..... 79
72 Error Code..... 81
76 Error Code..... 84
79 Error Code..... 85
80 Error Code..... 89
82 Error Code..... 92
90 Error Code..... 94
92 Warning Code..... 95
93 Error Code..... 95
99 Error Code..... 94

HOW TO REMOVE COMPONENTS

- Section 1: Control Board Bracket...98**
- Section 2: Blower Motor...100**
- Section 3: Flame Rod; Igniter Rod; Igniter Coil...102**
- Section 4: Orifice Assembly...104**
- Section 5: Burner Assembly...106**
- Section 6: Gas Control Valve...107**
- Section 7: Water Control Valves...111**
- Section 8: Heat Exchanger Thermistor...114**
- Section 9: Outlet Thermistor...116**
- Section 10: Inlet Thermistor...118**
- Section 11: Ambient Thermistor...120**
- Section 12: Control Board...122**
 - **How to Program Control Board...123**

Installation Guidelines for HIGH-Efficiency ONLY:

GAS TYPE: Liquid Propane (LP) or Natural (NG)

NG MAX INLET GAS PRESSURE: 10.5 (In. of w.c.)

NG MIN INLET GAS PRESSURE: 4.0 (In. of w.c)

LP MAX INLET GAS PRESSURE: 13.0 (In. of w.c.)

LP MIN INLET GAS PRESSURE: 8.0 (In. of w.c.)

MAX INPUT RATE: 199,900 (Btu/hr)

MIN INPUT RATE: 11,000 (Btu/hr)

GAS CONNECTION: 3/4" NPT

ELECTRICAL CONSUMPTION:

Normal: 100 W

Standby: 3-5 W

Antifreeze Protection: 200 W

MINIMUM ACTIVATION FLOW RATE (gpm): 0.4

EXTINCTION FLOW RATE (gpm): 0.25

VENT SIZE (Indoor ONLY): 2" or 3"

Installation Guidelines for HIGH-Efficiency ONLY:

The vent exhaust and air intake must be vented outside as described in the use and care manual. **DO NOT** vent this water heater through a chimney. It must be vented separately from all other appliances.

NOTICE: The unit can be vented using only the following recommended pipe material.

Use only 2 – or 3-inch diameter pipe. Refer to local codes for restrictions on the use of PVC, CPVC, or ABS pipe and fittings. All exhaust venting materials for product installed in Canada must meet ULC-S636.

Acceptable materials or equivalent:

PVC (Schedule 40, ASTM D-1785)

CPVC (Schedule 40, ASTM F-441)

ABS (Schedule 40, ASTM D-2661) (Not permitted in Canada)

The fittings other than the VENT TERMINAL should be equivalent to the following:

PVC (Schedule 40, DMW, ASTM D-2665)

CPVC (Schedule 40, DMW, ASTM F-438)

ABS (Schedule 40, DMW, ASTM D-2661) (Not permitted in Canada)

Category III Stainless Steel

DO NOT USE Schedule 20, Cell Core, Drain Pipe, Galvanized, Aluminum, or B-Vent.

| Number of 90 Degree Elbows | Maximum Length of 2" Straight Pipe | Maximum Length of 3" Straight Pipe |
|----------------------------|------------------------------------|------------------------------------|
| 0 or 1 | 5 ft. | 38 ft. |
| 2 | 3.5 ft. | 36.5 ft. |
| 3 | 2.0 ft. | 35 ft. |
| 4 | Not available | 33.5 ft. |
| 5 | Not available | 32 ft. |

Installation Guidelines for MID-Efficiency ONLY:

GAS TYPE: Liquid Propane (LP) or Natural (NG)

NG MAX INLET GAS PRESSURE: 10.5 (In. of w.c.)

NG MIN INLET GAS PRESSURE: 4.0 (In. of w.c.)

LP MAX INLET GAS PRESSURE: 13.0 (In. of w.c.)

LP MIN INLET GAS PRESSURE: 8.0 (In. of w.c.)

MAX INPUT RATE: 199,900 (Btu/hr)

MIN INPUT RATE: 11,000 (Btu/hr)

GAS CONNECTION: 3/4" NPT

ELECTRICAL CONSUMPTION:

Normal: 100 W

Standby: 3-5 W

Antifreeze Protection: 200 W

MINIMUM ACTIVATION FLOW RATE (gpm): 0.4

EXTINCTION FLOW RATE (gpm): 0.25

VENT SIZE (Indoor ONLY): 3"/5" concentric

Installation Guidelines for MID-Efficiency ONLY:

WARNING:

- Use 3-in. /5-in. UL-approved Category III Stainless Steel vent materials or water heater manufacturer-approved vent material. No other vent material is permitted for use with this appliance.

Venting Requirements

The installation of the venting must comply with national codes, local codes and the vent manufacturer's instructions.

The water heater must be vented to the outdoors. DO NOT vent this water heater through a chimney. It must be vented separately from all other appliances.

All coaxial vent components (adapters, pipe, elbows, terminals, etc.) should be water heater manufacturer-approved Stainless Steel Venting Material (e.g., AL29-4C).

| Number of 90 Degree Elbows (bends) | Maximum Length of Straight Pipe |
|------------------------------------|---------------------------------|
| 1 | 39 ft. |
| 2 | 37 ft. |
| 3 | 36 ft. |
| 4 | 34 ft. |
| 5 | 33 ft. |
| 6 | 31 ft. |

MID-EFFICIENCY FLOW RATES

64DV & 64X

| Temperature Rise (° F) | | | | | | | | |
|---|-----|-----|-----|-----|-----|-----|-----|-----|
| 35 | 45 | 50 | 60 | 70 | 77 | 80 | 90 | 100 |
| 6.4 | 5.6 | 5.1 | 4.2 | 3.6 | 3.3 | 3.2 | 2.8 | 2.5 |
| Max Water Flow - GPM (gallons per minute) | | | | | | | | |

84DV & 84X

| Temperature Rise (° F) | | | | | | | | |
|---|-----|-----|-----|-----|-----|-----|-----|-----|
| 35 | 45 | 50 | 60 | 70 | 77 | 80 | 90 | 100 |
| 8.4 | 6.7 | 6.1 | 5.1 | 4.3 | 3.9 | 3.8 | 3.4 | 3.0 |
| Max Water Flow - GPM (gallons per minute) | | | | | | | | |

95DV & 95X

| Temperature Rise (° F) | | | | | | | | |
|---|-----|-----|-----|-----|-----|-----|-----|-----|
| 35 | 45 | 50 | 60 | 70 | 77 | 80 | 90 | 100 |
| 9.5 | 7.4 | 6.6 | 5.5 | 4.7 | 4.3 | 4.1 | 3.7 | 3.3 |
| Max Water Flow - GPM (gallons per minute) | | | | | | | | |

HIGH-EFFICIENCY FLOW RATES (Condensing)

H84DV & H84X

| Temperature Rise (° F) | | | | | | | | |
|---|-----|-----|-----|-----|-----|-----|-----|-----|
| 35 | 45 | 50 | 60 | 70 | 77 | 80 | 90 | 100 |
| 8.4 | 6.6 | 6.0 | 5.0 | 4.3 | 3.9 | 3.7 | 3.3 | 3.0 |
| Max Water Flow - GPM (gallons per minute) | | | | | | | | |

H95DV & H95X

| Temperature Rise (° F) | | | | | | | | |
|---|-----|-----|-----|-----|-----|-----|-----|-----|
| 35 | 45 | 50 | 60 | 70 | 77 | 80 | 90 | 100 |
| 9.5 | 8.4 | 7.6 | 6.3 | 5.4 | 4.9 | 4.7 | 4.2 | 3.8 |
| Max Water Flow - GPM (gallons per minute) | | | | | | | | |

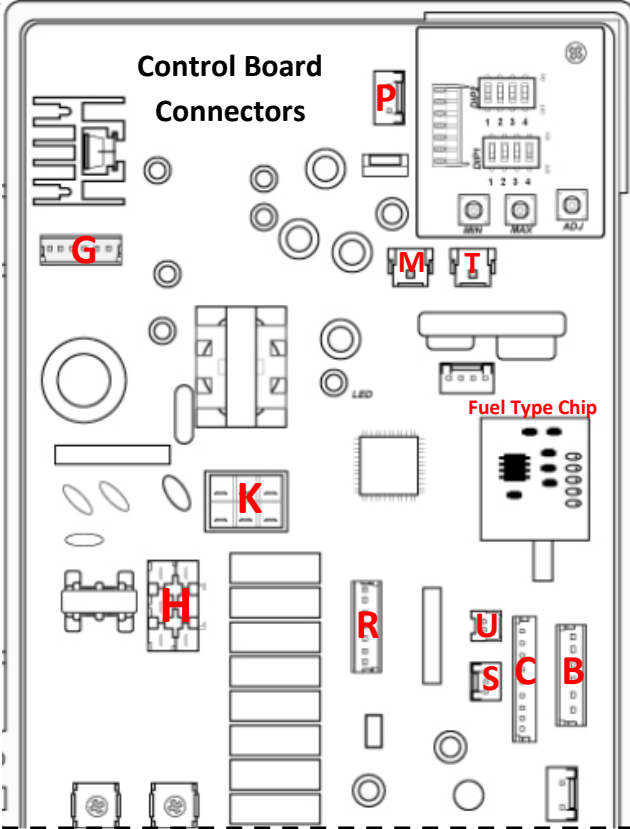

*****FUEL TYPE CHIP*** – When replacing Control Board, you must use the original chip on the new Control Board. New Control Board must be programmed (refer to page 122).**

P – Red, Red (High Efficiency ONLY)

M – White Molex: Grey

T – Blue Molex: Blue (Indoor Models ONLY)

K – Red, Black, Green, Yellow, White, Grey, Blue

H – White, White, Grey, Grey

U – White, White

S – Brown, Black, Red

C – Brown, White, Orange, Blue, Yellow, Green, Red, Black

B – Brown, White, Orange, Blue, Yellow, Green, Red, Black

G – Indoor Units: Blue, Yellow, White, Black, Red

G – Outdoor Units: Yellow, Orange, Red, Blue, White

R – Mid Efficiency: Red, Black, Black, Red, Yellow, White, Blue

R – High Efficiency: Red, Black, Black, Red, Green, White, Blue

Connector Wire Colors

CONTROL BOARD CONNECTORS

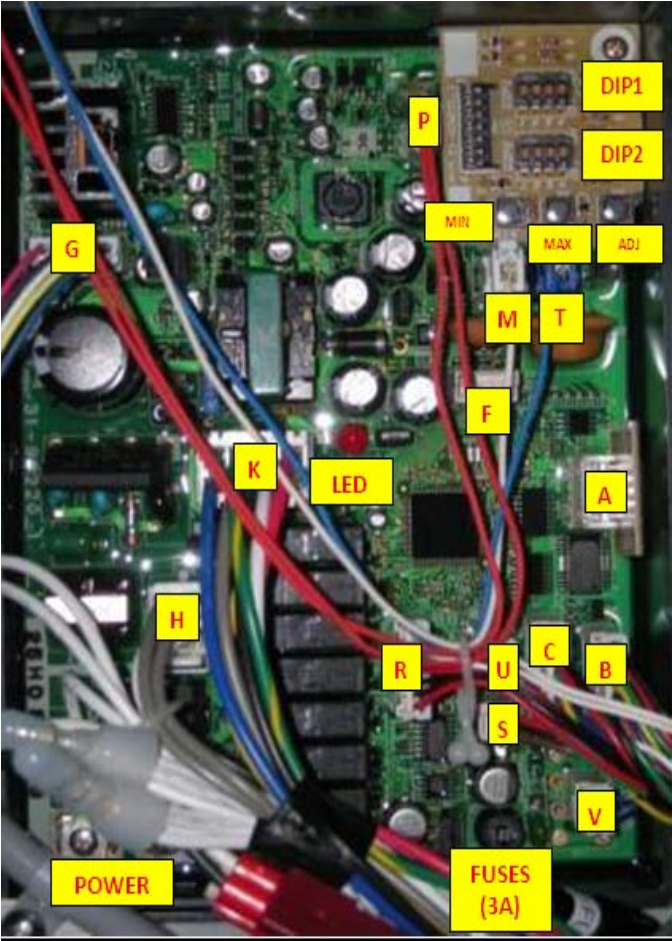

Diagnostic Points on Control Board

| Connection | Wire Color | Normal Value | What are you checking? |
|------------|------------|---|--|
| I – J | W1-BK2 | AC108-132V | Do you have power to the control board? |
| U | W1-W2 | 50K Ω -500K Ω | Is the overheat film wrap OK? |
| S | BR1-BK2 | DC 2-5V (Pulse) More than 1,310 pulses/minute | Does the water flow sensor send a pulse? (Only when water is flowing thru the unit) |
| S | R3-BK2 | DC 11-17V | Does the water flow sensor have voltage? (Power ON; no water flow) |

| Connection | Wire Color | Normal Value | What are you checking? |
|------------|--|--------------------------------|---|
| G | BK4-R6 | DC 144-192V | Does the fan motor have the proper voltage? |
| | W3-BK4 | DC 12-18V | Is the overheat film wrap OK? |
| | BR1-BK2 | DC 4-10V (Pulse) | Is the fan motor producing regular pulse? |
| R | W6-BK3 | 68°F=10.3KΩ 104°F=4.9KΩ | Is the water inlet thermistor working? |
| R | <i>Mid-Efficiency:</i> Y5-BK3 <hr/> <i>High-Efficiency (condensing):</i> G5-BK3 | 68°F=10.3KΩ 104°F=4.9KΩ | Is the heat exchanger thermistor working? |

| Connection | Wire Color | Normal Value | What are you checking? |
|------------|------------|--|---|
| R | R4-BK3 | 68°F=10.3KΩ 104°F=4.9KΩ | Is the water outlet thermistor working? |
| R | BL7-BK4 | <p><i>Mid-Efficiency INDOOR Units:</i></p> <p>68°F=10.3KΩ</p> <p>104°F=4.9KΩ</p> <hr/> <p><i>ALL OUTDOOR & ALL CONDENSING units:</i></p> <p>68°F=10.3KΩ</p> <p>104°F=4.9KΩ</p> | Is the ambient air thermistor working? |

| Connection | Wire Color | Normal Value | What are you checking? |
|------------|------------|----------------------|---|
| R | R1-BK2 | DC1.5-14V 40Ω-80Ω | Is the P.G.F.R. valve operating? (Proportional Gas Flow Regulator – full modulating valve) |
| M | W1-GND | AC 1-100 V | Flame rod detecting flame? |
| T | BL1-GND | AC 1-100 V | Flame rod detecting flame? |
| H | GY3-GY4 | AC 108-132 V | Is the igniter working properly? |

| Connection | Wire Color | Normal Value | What are you checking? |
|------------|------------|---|------------------------------|
| K | Y1-BK6 | DC 90-120 V 0.8K Ω -2.4K Ω | Gas inlet solenoid valve OK? |
| K | W2-BK6 | DC 90-120 V 0.8K Ω -2.4K Ω | Solenoid valve 1 OK? |
| K | GY3-BK6 | DC 90-120 V 0.8K Ω -2.4K Ω | Solenoid valve 2 OK? |
| K | R5-BK6 | DC 90-120 V 0.8K Ω -2.4K Ω | Solenoid valve 3 OK? |
| K | BL4-BK6 | DC 90-120 V 0.8K Ω -2.4K Ω | Solenoid valve 4 OK? |

Maintenance Mode Panel Display INSTRUCTIONS

The Rheem/Ruud Tankless has a maintenance mode chart on the remote control. To access the maintenance mode, turn the unit OFF at remote control and make sure water flow is OFF. Then hold down the UP and DOWN arrow keys at the same time for 5 seconds. You will hear an audible beep and see the display go to 1E (NOTE: Unit will default to 120° F). By pressing the UP and DOWN arrow keys on the remote control, you can access a variety of information about the water heater. To activate the unit while displaying the maintenance panel: push the power button once, open a hot water fixture, and the green LED will illuminate. This will allow you to access a variety of real time information while the unit is in operation.

Shortcut: (See Diagram on Page 22) DIP1 - Lift dip switch #1 to the up position to go immediately into maintenance mode. This can be done while the water heater is in operation.

(NOTE: Unit will maintain the set temperature)

While in maintenance mode you want to push the UP arrow key to select the table you wish to view. The table is designated by a letter and is always displayed as the second digit. Then push the DOWN arrow key to display the number item in the table you selected. The number is always displayed as the first digit. You can select as many as 8 readings for each table.

To perform diagnostics in this service manual, press the UP arrow until you get to table1Y.

Now using your DOWN arrow you can change the number in front of Y. As you move through the diagnostic readings, the selected table will flash first and then the diagnostic reading.

(Maintenance Mode Table on Page 23)

You will see the following as you navigate the Y table in maintenance mode:

- 0Y** = Flame rod status
- 1Y** = Water flow in gallons per minute
- 2Y** = Ambient air temperature
- 3Y** = Water inlet temperature
- 4Y** = Heat exchanger temperature
- 5Y** = Hot water outlet temperature
- 6Y** = Fan speed (x 100 rpm)
- 7Y** = Power for modulating gas valve
- 8Y** = Null (no reading)
- 9Y** = Null (no reading)

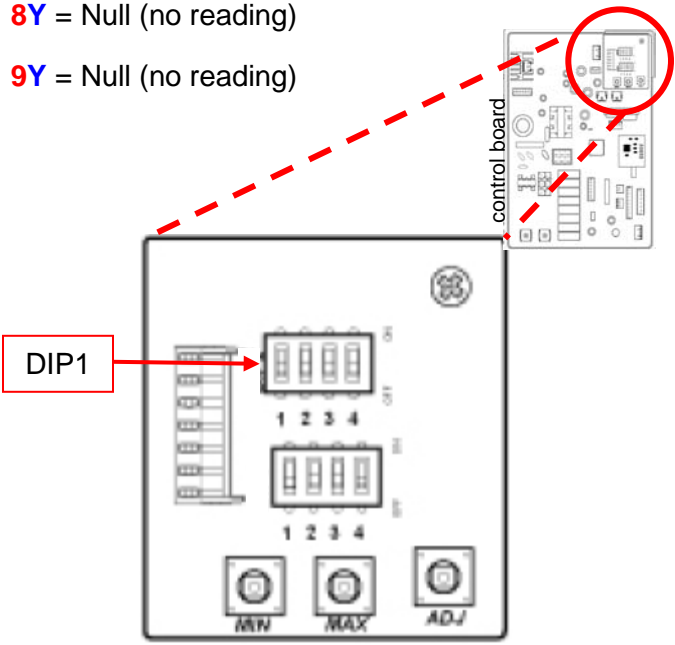

MAINTENANCE INFORMATION TABLE

* FIRST DIGIT: Use DOWN (▼) arrow key on Remote Control *

* SECOND DIGIT: Use UP (▲) arrow key on Remote Control *

| | *0 | *1 | *2 | *3 | *4 | *5 | *6 | *7 | *8 | *9 |
|----|------------------|--|---------------------|------------------------------|----------------------------|------------------------------|--------------------|-------------------------|------|-----------------|
| *E | Null | Fault codes for the most recent 8 faults | | | | | | | | |
| *F | Null | Sequence number of the most recent 8 faults | | | | | | | | |
| *C | | Total combustion times until recent error fault (*** x 10,000 times) | | | | | | | | |
| *D | | Total combustion times until recent error fault (** x 100 times) | | | | | | | | |
| *H | | Total combustion period until recent error fault (*** x 1,000 hours) | | | | | | | | |
| *J | | Total combustion period until recent error fault (** x 10 hours) | | | | | | | | |
| *Y | Flame Rod Status | GPM Flow Rate (° GPM) | Fan Detective Value | Cold Water Inlet Temperature | Heat Exchanger Temperature | Hot Water Outlet Temperature | Fan Speed x100 RPM | Power for PG.F.R. Valve | Null | Null |
| *A | Null | Control Line | Fan Detective Value | Fan Motor Current | Null | Null | Null | Null | Null | Sequence Number |

Altitude Settings on Control Board

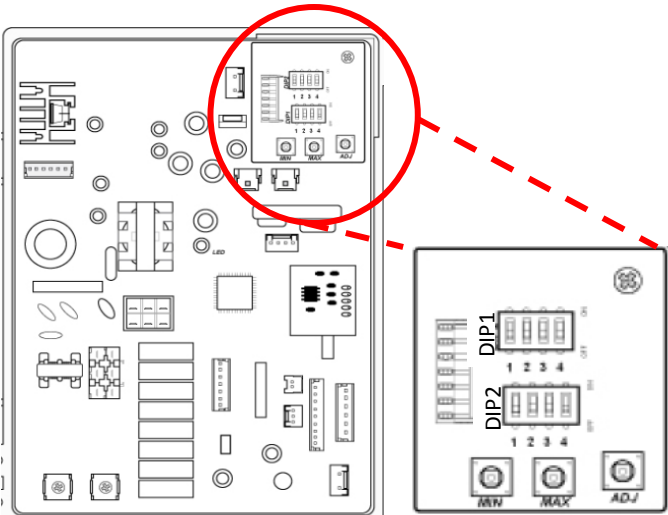

Locate the two DIP switches at top right of Control Board. Switch labeled DIP2 is the bottom switch. Altitude adjustments must be performed on DIP2 ONLY.

| | |
|--|---|
| | <p>Sea Level (0 ft – 3280 ft)</p> <p>All switches should be in the OFF position (DOWN)</p> |
| | <p>3280 ft – 6560 ft</p> <p>3RD switch should be in the ON position (UP)</p> |
| | <p>6560 ft – 9840 ft</p> <p>4TH switch should be in the ON position (UP)</p> |

RESET PROCEDURE

ONLY for 'Hard Lockouts' - Error Codes: 10, 13 & 99

1. Turn remote control OFF; leave unit plugged in. Remove front cover. Locate the DIP Switches (Upper Right on the control board).
2. Make sure all the DIP Switches are OFF (down position).
3. Locate DIP1 – Switch #2 and turn it ON (up position) then immediately turn it OFF.
4. Within 5 seconds, press and hold the MIN and MAX buttons for at least 2 seconds.
5. The remote control will flash "UL" then it will go solid. This indicates the heater has been reset.
6. Release the buttons.
7. Turn remote control ON. You may operate unit.

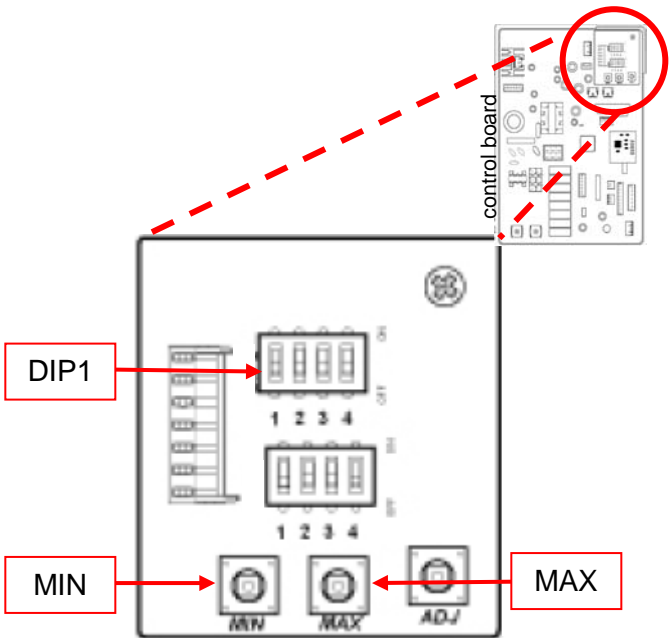

CLEARING FAULT HISTORY

1. Turn remote control OFF; leave unit plugged in. Remove front cover. Locate the DIP Switches (Upper Right on the control board).
2. Make sure all the DIP Switches are OFF (down position).
3. Locate DIP1 – Switch #1 and turn it ON (up position) then immediately turn it OFF.
4. Within 5 seconds, press and hold the MIN or MAX button for at least 2 seconds.
5. The remote control will flash “CL” then it will go solid. This indicates the fault history has been cleared.
6. Release the buttons.
7. You can verify clearing history by entering maintenance mode and check the code at location 1E. Should read NULL (- - two dashes).
8. Turn remote control ON. You may operate unit.

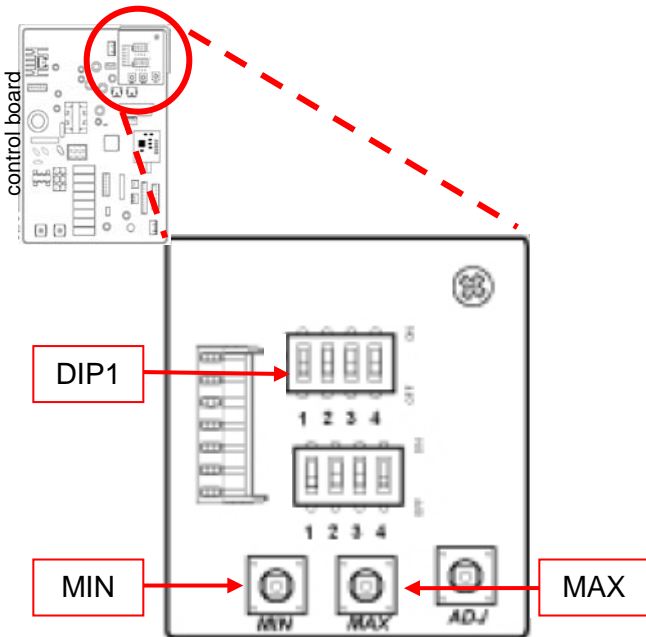

No Error Code & No Hot Water

Explanation: No hot water is delivered when water is flowing through unit and remote control displays the hot water temperature setting. [For 'NO POWER' complaint (remote control will not turn on) – check wall outlet for 120 volts. If voltage is present, check the two 3-amp fuses at the control board]

Possible Causes:

- Water flow (0.4 GPM to activate)
- DIP1 setting on main control board
- Water flow sensor

Water Flow:

1. Use cold water shutoff valve to turn OFF water supply to unit. Turn remote control OFF; unplug power cord at wall outlet. Wait 10 seconds; plug power cord back into outlet; wait 20 seconds; turn the remote control ON. Turn water supply ON; check the nearest hot water fixture for hot water.
2. Open multiple hot water fixtures. If unit fires then there is not enough water flow to engage the unit at a particular fixture. Check your fixture aerator screen(s) for debris. Clean if necessary.
3. Your water flow may be restricted by debris in water filter. Remove the water filter and inspect. Clean if necessary.
4. Your water lines might be crossed. Make sure your hot and cold water supply lines are connected to the appropriate hot and cold water assembly connections on the unit.

Single Unit Installations ONLY:

All DIP1 switches must be in the 'OFF' position (DOWN).

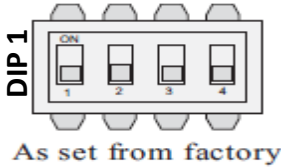

Manifold (Multiple) Unit Installations ONLY:

Go to 03 - Error Code to verify proper DIP1 setting.

Water Flow Sensor:

FINAL CHECK: Water flow sensor in water volume control valve.

Check connector 'S' between the Red and Black wires. With the unit ON and no water flow, you should read 11-17 DC volts. If not, replace the control board. IF you have voltage, then.....

With the water flowing, measure 2-5 DC volts between the Brown and Black wire. (This is measuring water flow thru the control). IF you have a reading and no main burner, replace the control board. If you do not have a reading, remove any debris from water volume control valve.

Connector Location
on Page 14

NOTES:

P1 - Warning Code

Explanation: No hot water is delivered when water is flowing through unit and remote control displays P1 - Warning Code.

Possible Causes:

- *Not Enough Water Flow*
 1. Turn the water supply to the unit OFF. Turn the remote control OFF, wait 10 seconds and turn the remote control ON. Turn the water supply to the unit ON and check the nearest hot water fixture for hot water. If you have hot water, then the unit needed to be reset.
 2. Your water lines might be crossed. Make sure your hot and cold water supply lines are connected to the appropriate hot and cold water connections on the unit.
 3. Your water flow may be restricted by a dirty In-Line Water Filter. Remove the water filter and inspect. Clean if necessary.
 4. Possible plumbing cross-over in the home. Turn OFF hot water valve to the water heater. Go to each water fixture in the home and turn ON the hot water ONLY (test washing machine by setting it to hot ONLY). If water flows freely through the hot water side of the fixture, this is a plumbing crossover. **HINT:** During this test, to prevent scalding, pressure-balancing valves on single-handle fixtures will not allow any water to flow if there is a plumbing crossover.
 5. Water flow might be too low. Open multiple hot water fixtures. If unit fires then there is not enough water flow to engage the unit at a particular fixture. Check your fixture aerator screen(s) for debris. Clean if necessary.
FOR RECIRCULATION LINES: check pump size, aqua-stat, check valve, and operation.

1L - Warning Code

Explanation: The control board has detected lime build-up inside the heat exchanger. To prevent permanent damage to the unit, the unit must be drained and flushed.

Flushing procedures may need to be repeated for excessive lime and scale build-up.

***To reset 1L Code, hold down the MIN and MAX buttons at the same time for 10 seconds**

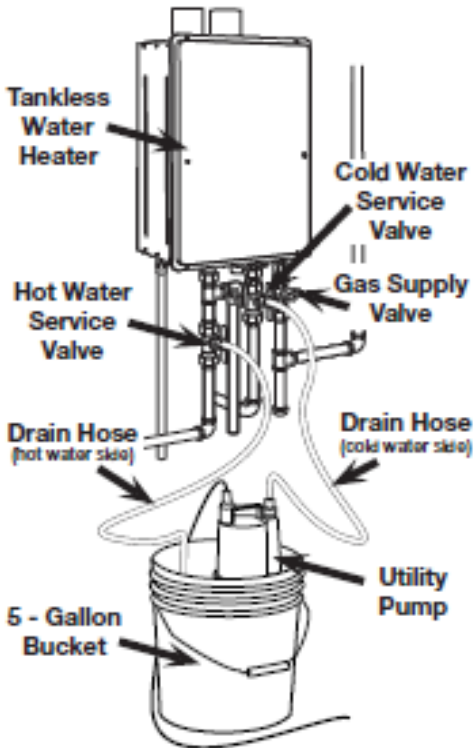

NOTE: Flushing instructions utilize a submersible utility pump (provided with the Rheem/Ruud Tankless Flush Kit – RTG20124)

1. Turn OFF gas and both the cold and hot water supply to the water heater. The gas must remain OFF during the flushing process.
2. At the remote control, turn OFF the power and wait 10 seconds. Turn ON the power and wait 10 seconds. Disconnect the water heater from the electrical source.
3. Connect a hose to the hose connections on the service valves under the water heater.
4. Place the loose end of the hoses into a 5-gallon bucket.
5. Open the service port valve on each side of the service valves, to allow the heater to drain. Connect the cold water side hose to the outlet side of the utility pump and set the pump into the bottom of the bucket.
6. Pour 2 gallons of **virgin food grade white vinegar** into the bucket and turn the pump ON.
7. Allow the pump to circulate the vinegar for 45 to 60 minutes. (time will vary depending upon mineral build-up and hardness of the water)
8. Turn OFF the pump and remove the hose from the pump. Allow the vinegar to drain from water heater into the bucket.
9. Place the hot water side hose in another bucket or route it to a suitable drain.
10. Close the service port valve on the cold water side and disconnect the cold water hose from the service valve.
11. Follow instructions in the Use & Care manual, supplied with the water heater, to clean the water inlet filter.
12. Turn ON the cold water supply to the heater. **DO NOT TURN ON THE HOT WATER SUPPLY TO THE HEATER.** Water will begin to flow through the heater; this will rinse out any remaining vinegar from the water heater. Allow the water to run for approximately 5 minutes.
13. Close the hot water service port valve and disconnect the drain hose.
14. Open a hot water fixture in the home, such as a tub. Allow the water to flow for a minute to ensure there is no air remaining in the system. Turn OFF the hot water fixture.
15. Reconnect power to water heater, turn ON gas supply, and turn ON power at the remote control.
16. Turn ON a hot water fixture to ensure the water heater is operating.

03 - Error Code

**Only for manifold (multiple) unit installations:
EZ-Link; MIC-6; or MIC-185 manifold controllers.**

Explanation: Communication failure between water heaters, remote control, and/or manifold controller.

Diagnostic Checks:

- *DIP1 setting on main control board (PCB)*

DIP1 SETTING:

Manifold units only: DIP1, switch #4 must be in the 'ON' position (UP) for each unit.

Check ALL Molex connections on ALL control boards.

Control Board Layout for third generation models

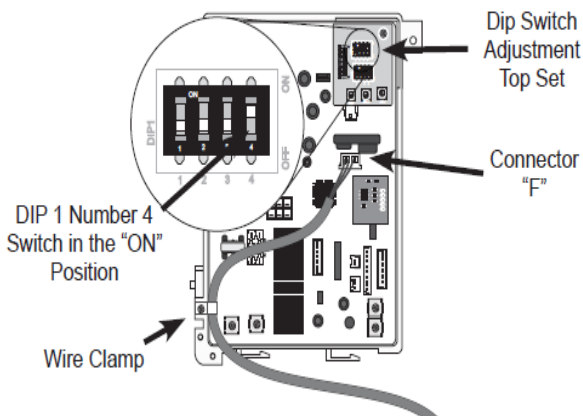

If 03 - Error Code is displayed after completing all checks: Call Technical Support (800)-432-8373

05 – Warning Code

Explanation: The flame rod has detected improper burner combustion (Indoor Units ONLY). This warning code is commonly caused by VENTING and/or GAS SUPPLY.

Diagnostic Checks:

- **GAS SUPPLY & VENTING** (refer to pages 8-11)
- **DIP2 setting on main control board**

Make sure DIP2 on control board is set to the correct altitude. Refer to Page 25 for altitude settings.

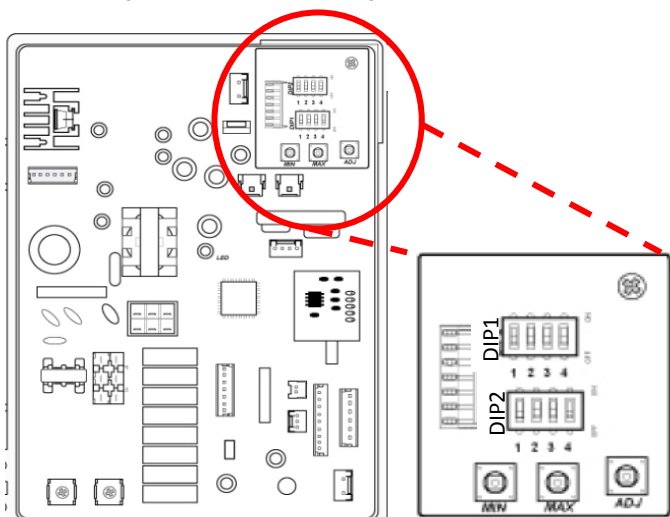

10 – Warning Code

Explanation: Unit was operated prior to vent installation OR blower motor is not creating enough ventilation.

First: Follow reset procedure on page 26.

Next: Check VENTING.

Diagnostic Checks:

- **VENTING (refer to pages 8-11)**
- Blower motor

Remove control board bracket (How to Remove: Section 1).

Remove blower motor (How to Remove: Section 2).

Clean blower motor and blower motor housing.

Reassemble & operate unit.

Does 10 – Warning Code appear?

YES

Locate MIN & MAX buttons on upper right-hand corner of control board.

Continue diagnostics on next page.

NO

Blower motor needed to be cleaned or you had a loose connection.

Unit appears to be operating OK.

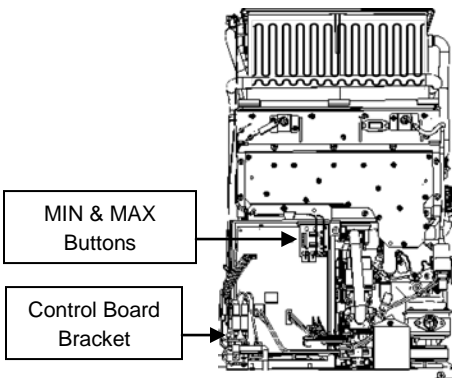

Blower Motor Diagnostics: INDOOR Models ONLY

Test DC voltage across Black and Red wires on connector "G":
144 – 192 DC Volts

NO

Remove & reinsert "G".
Operate unit again.
IF Code 10 appears:
Replace control board.

YES

Hold down MAX button.
Test DC voltage across Black & White wires on connector "G":
12 – 18 DC Volts

NO

Remove & reinsert "G".
Operate unit again.
IF Code 10 appears:
Replace control board.

YES

Hold down MAX button.
Test DC voltage across Black & Blue wires on connector "G":
4 – 10 DC Volts

NO

Remove & reinsert "G".
Operate unit again.
IF Code 10 appears:
Replace blower motor.

YES

Control board and blower motor are OK.
CHECK VENTING.

Connector Location
on Page 14

IMPORTANT: While performing voltage checks, DO NOT touch multi-meter leads across BLUE & WHITE wires. Damage may occur to blower motor & control board

Upper Right-Hand Corner of Control Board

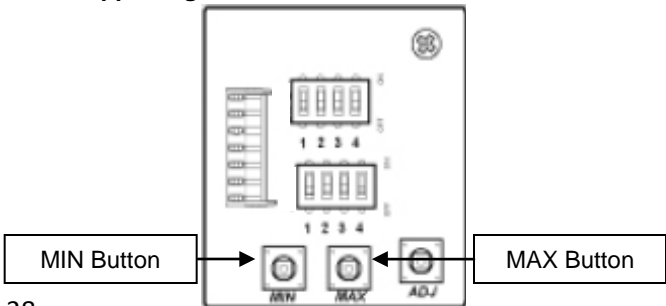

Blower Motor Diagnostics: OUTDOOR Models ONLY

Test DC voltage across Blue and White wires on connector "G":
144 – 192 DC Volts

NO

Remove & reinsert "G".
Operate unit again.
IF Code 10 appears:
Replace control board.

YES

Hold down MAX button.
Test DC voltage across Blue & Red wires on connector "G":
12 – 18 DC Volts

NO

Remove & reinsert "G".
Operate unit again.
IF Code 10 appears:
Replace control board.

YES

Hold down MAX button.
Test DC voltage across Blue & Yellow wires on connector "G":
4 – 10 DC Volts

NO

Remove & reinsert "G".
Operate unit again.
IF Code 10 appears:
Replace blower motor.

YES

Control board and blower motor are OK.
CHECK VENTING.

Connector Location
on Page 14

IMPORTANT: While performing voltage checks, DO NOT touch multi-meter leads across YELLOW & RED wires. Damage may occur to blower motor & control board

Upper Right-Hand Corner of Control Board

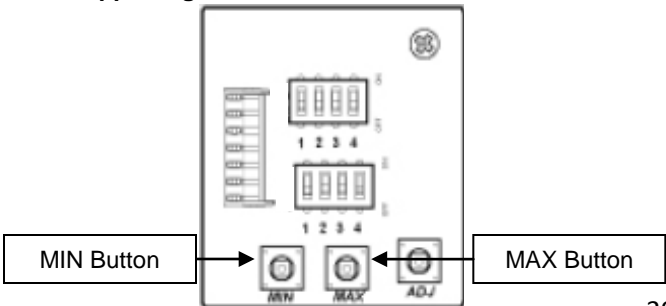

11 – Error Code

Explanation: Flame rod(s) does not detect flame. Commonly GAS SUPPLY and/or VENTING.

HINT: Make sure DIP2 (altitude setting) is properly set – see page 25.

IMPORTANT:

If all water heater components test 'OK', you must thoroughly inspect your GAS SUPPLY & VENTING.

Diagnostic Checks:

- **GAS SUPPLY & VENTING (refer to pages 8-11)**
- Igniter rod
- Flame rod(s)
- Gas control valve

Connector Location
on Page 14

Igniter Rod Diagnostics (spark is NOT visible)

Turn Power OFF. Remove and reinsert: connector 'H' (White Molex on bottom of igniter coil) & black insulated igniter cable on igniter rod. Turn Power ON. Operate unit and determine IF spark is visible through sight glass.

YES

You had a loose connection.

Igniter is OK.

NO

Continue diagnostics on next page.

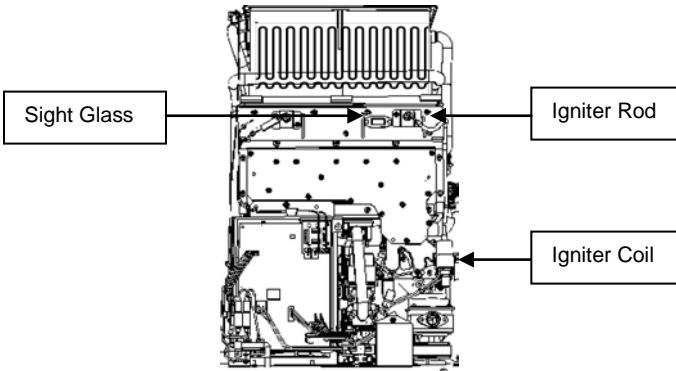

Igniter Rod Diagnostics (spark is NOT visible)

While attempting to ignite, test AC Volts across 2 Grey wires on connector "H":
108 – 132 AC Volts

NO

Remove & reinsert "H".
Operate unit again.
IF 11 – Error code appears:
Replace control board.

YES

Turn power & GAS OFF. Remove and hold igniter cable 1/8 inch from igniter connection. With GAS OFF, operate unit. Determine IF there is a spark at igniter connection.

NO

Replace igniter coil.

YES

Turn power OFF. Remove and clean igniter rod. Reassemble & operate unit. Is spark visible through sight glass?

NO

Replace igniter rod.

YES

Igniter rod needed to be cleaned and is OK. Turn GAS ON and check for normal operation.

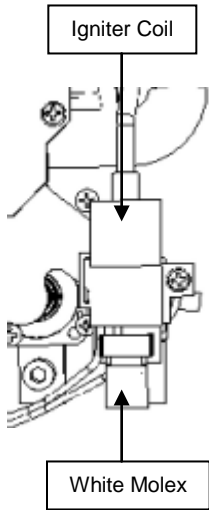
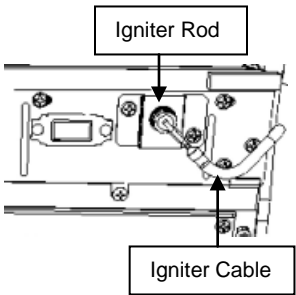

Flame Rod Diagnostics (flame IS visible)

Turn Power OFF. Remove and reinsert connector “M”, “T”, & terminal on flame rod(s). Turn Power ON. While viewing through sight glass, operate unit to determine IF flame is touching the flame rod(s).

Indoor models – 2 flame rods (Connectors “M” & “T”).

Outdoor models – 1 flame rod (Connector “M”).

YES

Access maintenance mode to check flame rod status & continue to diagnostic chart on next page.

NO

Remove any foreign debris. IF foreign debris is not present: CHECK GAS SUPPLY & VENTING.

Connector Location
on Page 14

(See maintenance mode instructions on page 21)

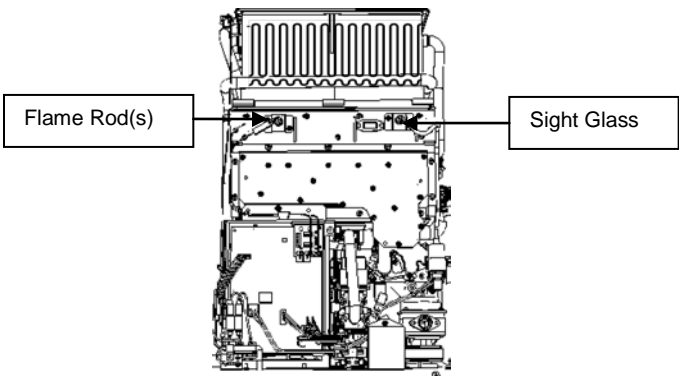

Flame Rod(s) Diagnostics

Test AC volts on connector "M" (Grey wire to Ground)
1 – 100 AC Volts

NO

Remove & reinsert "M". Operate unit again. IF code 11 appears: Replace control board.

YES

Test AC volts on connector "T" (Blue wire to Ground)
1 – 100 AC Volts

NO

Remove & reinsert "T". Operate unit again. IF code 11 appears: Replace control board.

YES

Cycle unit ON; while in maintenance mode, check flame rod status under table 0Y. IF flame rod(s) is detecting flame, maintenance mode will display:
Indoor Models - 05
Outdoor Models - 01

NO

Clean flame rod(s). Operate unit again. IF still does not detect flame: Replace flame rod(s).

YES

Flame rod(s) test OK. CHECK GAS SUPPLY, VENTING, & GROUND.

Outdoor: 1 flame rod
White Molex – Grey Wire

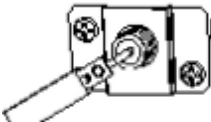

Indoor: 2 flame rods
White Molex – Grey Wire
Blue Molex – Blue Wire



Gas Control Valve Diagnostics (Igniter Rod Sparks & NO flame)

IMPORTANT: DURING VOLTAGE CHECKS – CONNECTOR “K” ONLY (water is flowing and unit is attempting to ignite): IF you do NOT get a voltage reading, push and hold the MAX button on upper right hand corner of control board to activate unit at full BTU’s. This will force voltage to ALL gas valve solenoids during diagnostics.
CAUTION: DO NOT hold MAX button down for more than 5 Seconds *MAY CAUSE DAMAGE TO THE HEAT EXCHANGER*.

Turn Power OFF.
 Remove and reinsert connectors “K” & “R”. (Connector “K” is Gas Valves. Connector “R” is PGFR valve.)
 Locate PGFR valve on lower right side of unit (round black piece on bottom of gas valve. PGFR is a full modulating gas valve).
 Remove and reinsert Molex connectors with Red and Black wires on PGFR.
 Turn Power ON.
 While viewing through sight glass, operate unit to determine IF flame is visible.

YES

You had a loose connection.

 Gas control valve is OK.

NO

Continue diagnostics on next page.

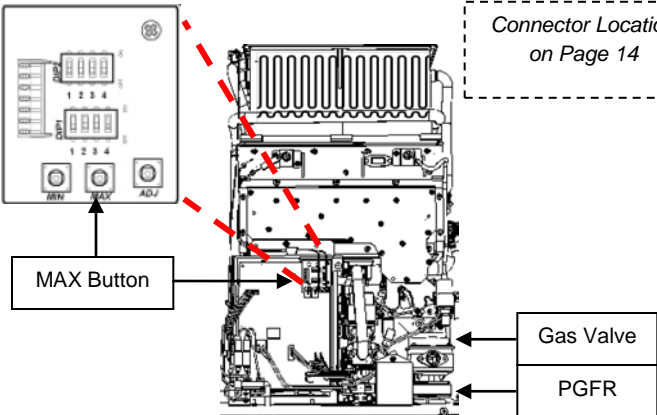

Gas Control Valve Diagnostics

While attempting to ignite test DC volts across #1 wire (Red) & #2 wire (Black) on connector "R":
1.5 – 14 DC Volts

NO

Remove & reinsert "R". Operate unit again. IF code 11 appears:

Replace control board.

YES

Turn power OFF. Remove connector "R" & measure resistance across same wires:
40 – 80 OHMS

NO

Remove & reinsert PGFR connectors. Retest "R". IF resistance test fails:
Replace gas control valve.

YES

Turn power OFF. Remove connector "K". On connector "K": Using the BLACK WIRE as the common – individually check resistance for Yellow, White, Grey, Red, & Blue wires:
0.8K – 2.4K OHMS

NO

Make sure all wires are connected to Gas Control Valve. Retest connector "K". IF test fails:
Replace gas control valve.
NOTE: IF Grey wire failed ohms test, replace manifold assembly.

YES

Gas control valve is OK. Reconnect connector "K". Turn power ON. While unit is attempting to ignite - On connector "K": Using the BLACK WIRE as the common – Individually check DC volts for Yellow, White, Grey, Red, & Blue wires:

90 – 120 DC Volts

NO

Remove & reinsert "K". Operate unit again. IF 11- Error Code appears:
Replace control board.

YES

Control board is OK. IF ALL components tested OK: CHECK GAS SUPPLY, VENTING, & GROUND.

12 – Error Code

Explanation: Commonly GAS SUPPLY and/or VENTING. Unit detected the presence of flame and then lost it.

HINT: Make sure DIP2 is properly set – see page 25.

Diagnostic Checks:

- **GAS SUPPLY & VENTING (refer to pages 8-11)**
- Flame rod(s)

Turn Power OFF. Remove and reinsert connector ‘M’; ‘T’; & terminal on flame rod(s). Turn Power ON. While viewing through sight glass, operate unit to determine IF flame is touching the flame rod(s).

Indoor models – 2 flame rods (Connectors “M” & “T”).

Outdoor models – 1 flame rod (Connector “M”).

Connector Location
on Page 14

YES

NO

Access maintenance mode to check flame rod status & continue to diagnostic chart on next page.

Remove any foreign debris. IF foreign debris is not present: CHECK GAS SUPPLY & VENTING.

(See maintenance mode instructions on page 21)

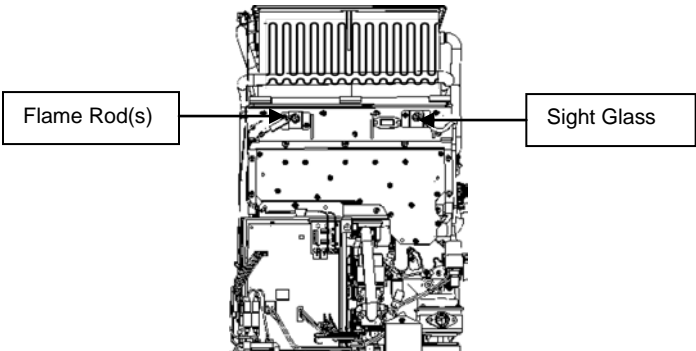

Test AC volts on connector "M" (Grey wire to Ground):
1 – 100 AC Volts

NO

Remove & reinsert "M".
Operate unit again. IF code 12 appears:
Replace control board.

YES

Test AC volts on connector "T" (Blue wire to Ground):
1 – 100 AC Volts

NO

Remove & reinsert "T".
Operate unit again. IF code 12 appears:
Replace control board.

YES

Cycle unit ON; while in maintenance mode, check flame rod status under table 0Y. IF flame rod(s) is detecting flame, maintenance mode will display:

Indoor Models - **05**
Outdoor Models - **01**

NO

Clean flame rod(s).
Operate unit again. IF still does not detect flame:

Replace flame rod(s).

YES

Flame rod(s) test OK.
CHECK GAS SUPPLY,
VENTING, & GROUND.

Outdoor: 1 flame rod
White Molex – Grey Wire

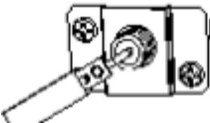

Indoor: 2 flame rods
White Molex – Grey Wire
Blue Molex – Blue Wire



13 – Error Code

Explanation: Indoor units ONLY. Flame rod is detecting poor combustion. This is commonly caused by inadequate GAS SUPPLY and/or VENTING.

HINT: Make sure DIP2 is properly set – see page 25. (If unit shuts down 5 times within a 4 hour period due to 13 – Error Code, the unit must be reset by performing reset procedure on page 26).

Diagnostic Checks:

- **GAS SUPPLY & VENTING (refer to pages 8-11)**
- Flame rod FL-2

Turn Power OFF. Remove and reinsert connector “T” & terminals on flame rods. Turn Power ON. While viewing through sight glass, operate unit to determine IF flame is touching the flame rod(s).

Indoor models – 2 flame rods (Connectors “M” & “T”).

Connector Location
on Page 14

YES

Access maintenance mode to check flame rod status & continue to diagnostic chart on next page.

NO

Remove any foreign debris. IF foreign debris is not present: CHECK GAS SUPPLY & VENTING.

(See maintenance mode instructions on page 21)

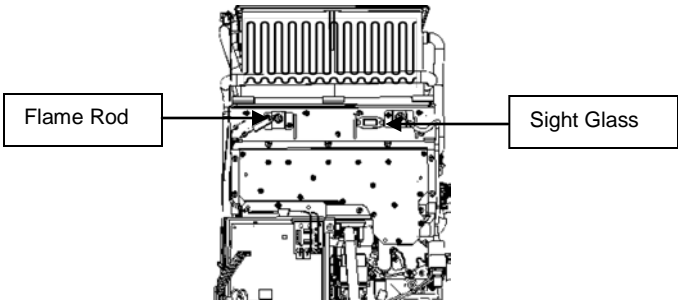

Test AC volts on connector "T" (Blue wire to Ground):
1 – 100 AC Volts

NO

Remove & reinsert "T". Operate unit again. IF code 13 appears:
Replace control board.

YES

Cycle unit ON; while in maintenance mode, check flame rod status under table 0Y. IF flame rod(s) is detecting flame, maintenance mode will display: **05**

NO

Clean flame rods. Operate unit again. If still does not detect flame:
Replace flame rods.

YES

Flame rod(s) test OK. Remove and clean the manifold assembly and burner assembly (How to Remove: Sections 4 & 5).

Reassemble and operate unit again. Did Error Code - 13 appear?

NO

Unit is operating correctly. Burner and/or manifold needed to be cleaned. CHECK the area around the air intake for the possible cause of dirty manifold and/or burner.

YES

CHECK GAS SUPPLY, VENTING, & GROUND.

Indoor: 2 flame rods
White Molex – Grey Wire
Blue Molex – Blue Wire



14 – Error Code

Explanation: OHL (Over Heat Limiter) or Over Temp Limit Switch activated. IF the OHL or Over Temp Limit Switch has been activated, this is normally caused by inadequate/wrong GAS SUPPLY and/or VENTING.

CHECK GAS SUPPLY & VENTING (refer to pages 8-11).

Diagnostic Checks:

Connector Location
on Page 14

- OHL
- High-Efficiency ONLY: Over Temp Limit Switch (monitors vent temperature)

Turn Power OFF. Remove & reinsert connector "U".
Attempt to operate unit.

Does 14 – Error Code appear?

YES

Continue diagnostics on next page.

NO

Unit had a loose connection or over temp limit switch cooled down. Unit appears to be operating OK.

**High-Efficiency Indoor (condensing) ONLY:
Locate the Over Temp Limit Switch (circled in red)**

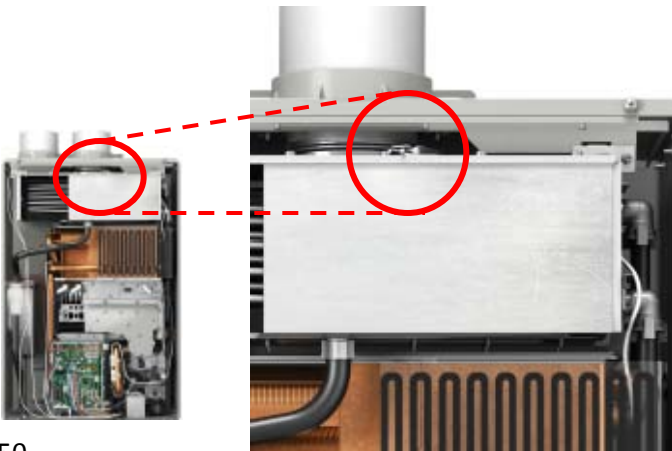

Turn power OFF.
Remove connector "U".
Measure resistance
across both White wires:

50K – 500K OHMS

NO

Mid Efficiency ONLY:
Replace Unit.

High Efficiency Indoor ONLY: Continue to
over temp switch
diagnostics.
(bottom of page)

YES

Reconnect connector
"U". Attempt to operate
unit.

NO

IF error code 14
appears:
Replace control board.

YES

Unit had a loose
connection. Operation
appears to be normal.

**Over Temp Limit Switch - High Efficiency Indoor
(Condensing) ONLY:**

Disconnect two White
Molex connectors for
the over temp limit
switch. On female end
of Molex, check
continuity across both
Black wires.

NO

Switch automatically
resets once it cools
down. Allow limit switch
to cool down. IF switch
does NOT have
continuity once unit
cools down:
Replace over temp limit
switch. IF switch
automatically resets,
check VENTING.

YES

Limit switch possibly cooled
down. Operate unit. IF
error code 14 appears and
you have continuity through
Over Temp Limit Switch:
Replace Unit.

15 – Error Code

Explanation: The hot water temperature and/or heat exchanger temperature reached 207 degrees F for more than 15 seconds.

IMPORTANT: Inadequate GAS SUPPLY and/or VENTING will create hot spots in the heat exchanger.

Diagnostic Checks:

- **GAS SUPPLY & VENTING (refer to pages 8-11)**
- Sediment build-up in heat exchanger
- Heat exchanger thermistor

Sediment Build-Up Diagnostics

Go to Error Code 1L for flushing instructions.

Heat Exchanger Thermistor Diagnostics

Go to Error Code - 32 for heat exchanger thermistor diagnostic instructions.

16 – Error Code

Explanation: Outlet water temperature is above the set point on the remote control.

IMPORTANT: Check the outlet thermistor FIRST.

Diagnostic Checks:

- Outlet thermistor
- Water bypass valve

Outlet Thermistor Diagnostics:

Go to Error Code 33 for outlet thermistor diagnostic instructions.

Water Bypass Valve Diagnostics:

Go to Error Code 66 for water bypass valve diagnostic instructions.

24 – Error Code

Explanation: Remote control buttons were depressed for more than 20 seconds, release buttons and operate unit. IF error code 24 appears again, continue to remote control diagnostics.

Diagnostic Checks:

- Remote control

Visually inspect remote control wiring for damaged or loose connections. Is wiring OK?

NO

Tighten loose connections or replace damaged wiring.

YES

Turn Power OFF & unplug unit from power source. Remove wires from wiring terminals on remote control and bottom of unit. Use a new short piece of wire to connect remote control directly to wiring terminals at bottom of unit. Plug unit in, turn power ON and open a hot water source. Does 24 – Error Code appear?

NO

Replace remote control wiring.

YES

Replace remote control.

29 – Error Code (A)

Explanation: High-Efficiency (condensing) Units ONLY: Condensation is NOT draining.

Diagnostic Checks:

- Plug not removed from condensate drain
- Pinch in condensate drain line
- Blockage in condensate drain line
- Drain line has unnecessary “P” trap

Condensate Drain Diagnostics:

1. Ensure you removed the condensate protection plug located at bottom of unit & attached a condensate drain line to the unit.
2. Check condensate drain line for internal or external blockage. Make sure drain line is NOT pinched.
3. Remove “P” trap on condensate drain line.

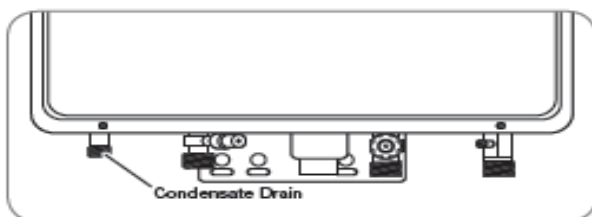
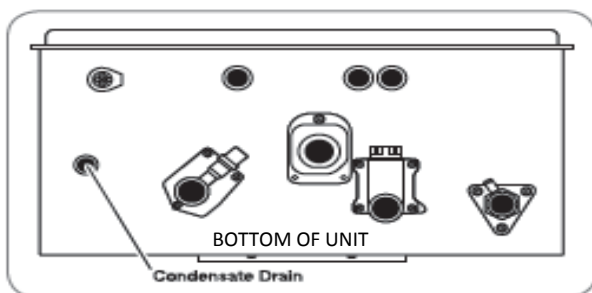

29 – Error Code (B)

Explanation: Heat exchanger temperature too low for more than 3 minutes.

HINT: High-Efficiency (condensing) Units ONLY: make sure condensate is draining properly prior to continuing diagnostics (go to previous page for diagnostics).

Diagnostic Checks:

- Inlet & heat exchanger thermistors
- Gas control valve
- Water volume control valve

Inlet thermistor Diagnostics:

Connector Location
on Page 14

Go to 31 – Error Code.

Heat Exchanger thermistor Diagnostics:

Go to 32 – Error Code.

HINT: ALWAYS diagnose thermistors before continuing to next steps.

1. Turn power OFF. Remove connector “R” & measure resistance across #1 wire (Red) and #2 wire (Black): 40-80 OHMS
2. Remove connector “K”. Using the BLACK WIRE as the common – Individually check resistance for Yellow, White, Red, & Blue wires: 0.8K – 2.4K OHMS

YES

Continue diagnostics on next page.

NO

Replace gas control valve.

Calculate Temperature Rise & Gallons per Minute:

1. Enter maintenance mode & select table 3Y. Turn on water flow to determine inlet water temperature.
2. Using the formula below, determine temperature rise.

Remote control temp - Incoming water temp = Temperature Rise

3. Select table 1Y. Using the incoming water shut off valve Turn OFF incoming water at the unit. Turn ON ALL hot water fixtures in the home/business to full flow. Using the incoming water shut-off valve, turn ON incoming water at unit. Determine MAX GPM flowing through unit.

****BEFORE continuing - Refer to pages 12 & 13 to obtain MAX GPM possible for appropriate model number.***

| | | |
|--|---|---|
| <p>With ALL hot water fixtures turned ON full flow, will the unit EXCEED MAX GPM it can produce?</p> | NO | <p>Remove & reinsert "C". Operate unit again. IF code 29 appears: Replace control board.</p> |
| YES | | |
| <p>Turn water & remote control OFF. Turn remote control ON. Open ALL hot water fixtures. Measure DC Volts across Black & White wires on connector "C": 8 – 16 DC Volts</p> | NO | <p>Remove & reinsert "C". Operate unit again. IF code 29 appears: Replace control board.</p> |
| YES | | |
| <p>Measure DC Volts across black & red wires on connector "C": 8 – 16 DC Volts</p> | NO | <p>Remove & reinsert "C". Operate unit again. IF code 29 appears: Replace control board.</p> |
| YES | | |
| <p>Replace water volume control valve.</p> | <p>Maintenance mode Instructions on Page 21</p> | |

31 – Error Code

Explanation: Inlet thermistor malfunction.

Diagnostic Checks:

- Inlet thermistor

Connector Location
on Page 14

Turn Power OFF. Remove connector "R". Measure resistance between #3 wire (Black) & #6 wire (White):

7K – 23K Ohms

YES

Reinsert connector "R".
Operate unit.
IF Error Code 31
appears:

Replace control board.

NO

Remove control board
bracket to access inlet
thermistor Molex near
blower motor (How to
Remove: Section 1).
Continue diagnostics on
next page.

Control Board
Bracket

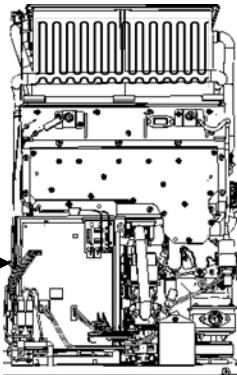

Locate & separate
WHITE Molex (located
near blower motor).
Check resistance across
White wires on female
end of Molex:

7K – 23K Ohms

NO

Clean scale build-up on
inlet thermistor.
Operate unit. IF Error
Code 31 appears:

Replace inlet thermistor.

YES

Reconnect Molex.
Check resistance on
connector "R" between
#3 wire (Black) and #6
wire (White):
7K – 23K Ohms

NO

Replace wiring harness
for connector "R".

YES

Reinsert connector "R".
Operate unit.
IF 31 - Error Code
appears:

Replace control board.

Molex Connectors

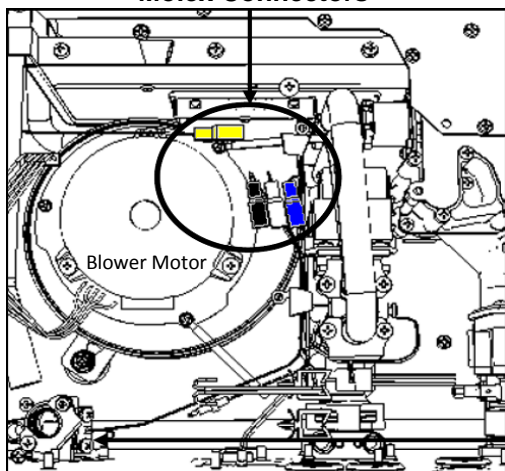

32 – Error Code

Explanation: Heat exchanger thermistor malfunction.

Diagnostic Checks:

- Heat exchanger thermistor

Connector Location
on Page 14

Turn Power OFF. Remove connector "R":

Mid-Efficiency Units ONLY: Measure resistance between #3 wire (Black) & #5 wire (YELLOW):

High-Efficiency Units ONLY: Measure resistance between #3 wire (Black) & #5 wire (GREEN):

7K – 23K OHMS

YES

Reinsert connector "R".
Operate unit.
IF 32 - Error Code
appears:

Replace control board.

NO

Remove control board
bracket to access heat
exchanger thermistor
Molex near blower
motor (How to Remove:
Section 1).

Continue diagnostics on
next page.

Control Board
Bracket

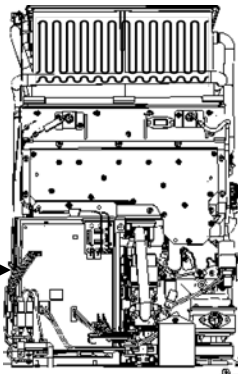

Locate & separate
YELLOW or GREEN
Molex (located near
blower motor). Check
resistance across White
wires on female end of
Molex:
7K – 23K OHMS

NO

Clean scale build-up on
heat exchanger
thermistor. Reassemble
& operate unit. IF Error
Code 32 appears:

Replace heat exchanger
thermistor.

YES

Reconnect Molex.
Check resistance on
connector "R" between
#3 wire (Black) and #5
wire (Yellow) or #3 wire
(Black) and #5 wire
(Green):
7K – 23K OHMS

NO

Replace wiring harness
for connector "R" on
control board.

YES

Reassemble & operate
unit. IF 32 - Error Code
appears:
Replace control board.

Molex Connectors

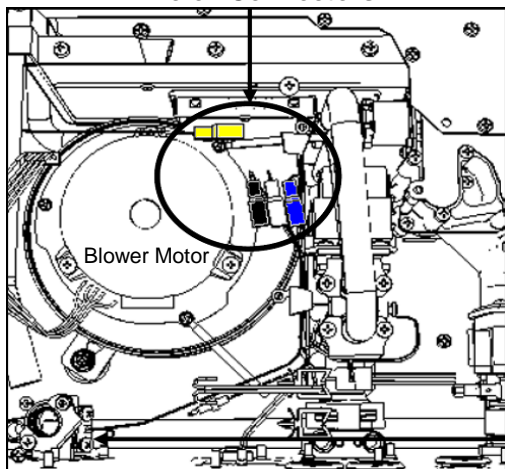

33 – Error Code

Explanation: Outlet thermistor malfunction.

Diagnostic Checks:

- Outlet thermistor

Connector Location
on Page 14

Turn Power OFF. Remove connector "R". Measure resistance between #3 wire (Black) & #4 wire (Red):

7K – 23K OHMS

YES

Reinsert connector "R".
Operate unit.
IF 33 - Error Code
appears:

Replace control board.

NO

Remove control board
bracket to access outlet
thermistor Molex near
blower motor (How to
Remove: Section 1).

Continue diagnostics on
next page.

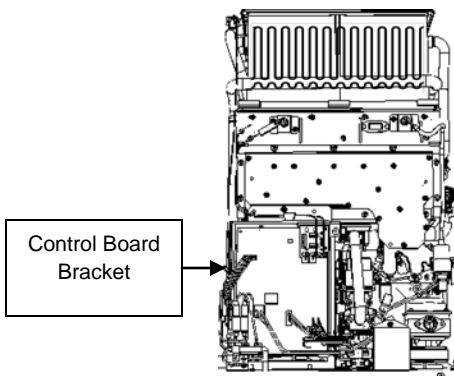

Locate & separate
BLACK Molex (located
near blower motor).
Check resistance across
black wires on Female
end of Molex:

7K – 23K OHMS

NO

Clean scale build-up on
outlet thermistor.
Reassemble & operate
unit. IF 33 - Error Code
appears:

Replace outlet
thermistor.

YES

Reconnect Molex.
Check resistance on
connector "R" between
#3 wire (Black) and #4
wire (Red):

7K – 23K OHMS

NO

Replace wiring harness
for connector "R" on
control board.

YES

Reassemble & operate
unit. IF 33 - Error Code
appears:

Replace control board.

Molex Connectors

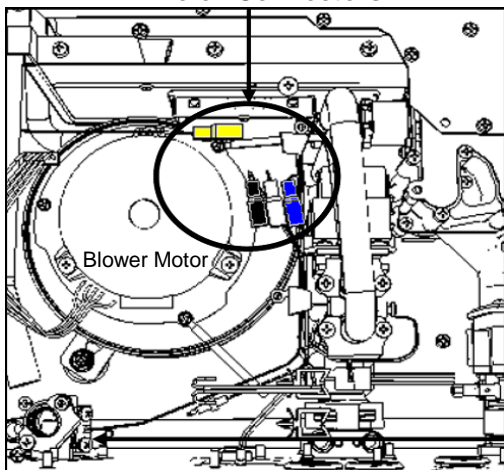

34 – Error Code

Explanation: Ambient thermistor malfunction.

Diagnostic Checks:

- Ambient thermistor

Connector Location
on Page 14

Turn Power OFF. Remove connector "R". Measure resistance between #3 wire (Black) & #7 wire (Blue):

64DV; 84DV; 95DV: 7K – 23K Ohms

64X; 84X; 95X; H95X; H95DV: 2K – 72K Ohms

YES

NO

Reinsert connector "R".
Operate unit.
IF 34 - Error Code
appears:

Replace control board.

Remove control board
bracket to access
ambient thermistor
Molex near blower
motor (How to Remove:
Section 1).
Continue diagnostics on
next page.

Control Board
Bracket

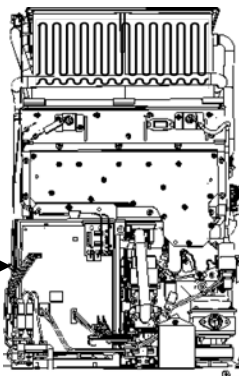

Locate & separate
BLUE Molex (located
near blower motor).
Check resistance across
black wires on Female
end of Molex:

2k – 72K OHMS
7K – 23K OHMS

NO

Clean scale build-up on
ambient thermistor.
Reassemble & operate
unit. IF Error Code 34
appears:

Replace ambient
thermistor.

YES

Reconnect Molex.
Check resistance on
connector "R" between
#3 wire (Black) and #7
wire (Blue):

2K – 72K OHMS
7K – 23K OHMS

NO

Replace wiring harness
for connector "R" on
control board.

YES

Reassemble & operate
unit. IF 34 - Error Code
appears:

Replace control board.

Molex Connectors

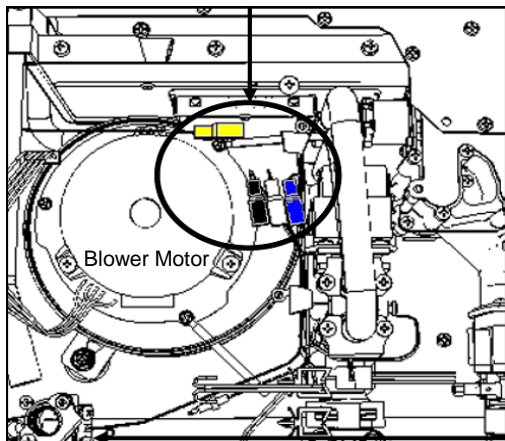

35 – Error Code

Explanation: Improper thermistor connection. Unit has four thermistors; one or more possibly has a poor connection or not connected in proper location.

Diagnostic Checks:

- Inlet, heat exchanger, outlet, & ambient thermistors

Connector Location
on Page 14

Turn Power OFF. Remove & reinsert connector "R".

Turn Power ON. Operate Unit.

Does 34 – Error Code appear?

YES

Test ALL thermistors.
Follow Instructions for:

- 31 – Error Code
- 32 – Error Code
- 33 – Error Code
- 34 – Error Code

NO

Unit had a loose
connection.

Thermistors appear to
be OK.

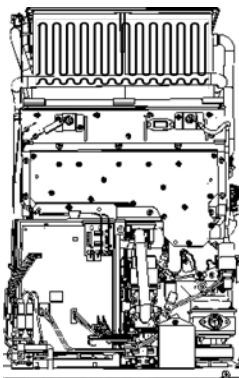

51 – Error Code

Explanation: Gas control valve malfunction. Unit detected the presence of flame when demand for hot water terminated & the unit turned OFF.

Diagnostic Checks:

- Flame rod(s)
- Gas control valve

Connector Location
on Page 14

Turn Power OFF. Remove and reinsert connector “M”, “T”, & terminal on flame rod(s). Turn Power ON. Operate unit. Did 51 – Error Code appear?

Indoor models – 2 flame rods (Connectors “M” & “T”).

Outdoor models – 1 flame rod (Connector “M”).

YES

Access maintenance mode to check flame rod status.
Locate sight glass.
Continue to diagnostic chart on next page.

NO

Unit had a loose connection or foreign debris that is no longer present.

Unit appears to be operating OK.

(See maintenance mode instructions on page 21)

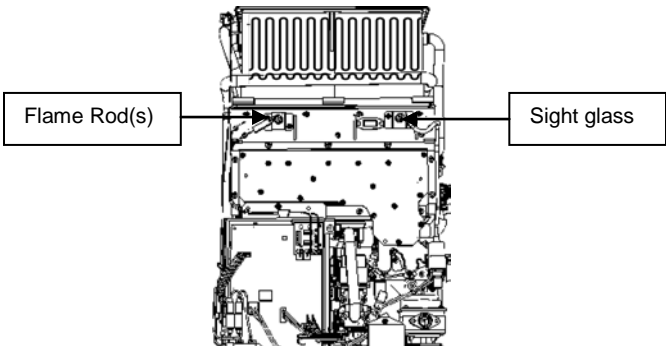

While viewing burner chamber through sight glass: In 10 second intervals, cycle unit 3 times -
ON-OFF; ON-OFF; ON-OFF

Determine if flame is visible when OFF.

NO

Follow maintenance mode instructions at bottom of page & continue to diagnostics on next page.

YES

Visually inspect burner chamber through sight glass for foreign debris.

NO

Operate unit. IF 51 – Error Code appears & flame IS visible while unit has been OFF longer than 5 seconds:
Replace gas control valve.

YES

Remove & clean burner assembly.

HINT: Open a hot water fixture & use water shut-off valve at the unit to cycle unit “ON-OFF”.

Outdoor: 1 flame rod

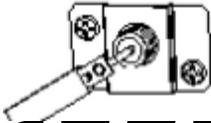

Indoor: 2 flame rods

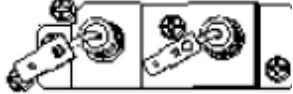

On remote control, go to maintenance mode 0Y table. For maintenance mode instructions go to page 21.

All maintenance mode ‘0Y’ readings should be done immediately after turning the unit OFF. IF Flame Rod(s) is detecting flame, maintenance mode will display:

Indoor Units: **05**
Outdoor Units: **01**

In 10 second intervals, cycle unit 3 times by turning unit:
ON-OFF; ON-OFF; ON-OFF

Does 0Y status in maintenance mode indicate presence of flame while unit has been off >5 seconds?

NO

Unit appears to be OK. Operate unit.
IF 51 – Error Code appears:
Replace control board.

YES

Disconnect wires at flame rod(s). While viewing burner chamber through sight glass: In 10 second intervals, cycle unit 3 times by turning unit:
ON-OFF; ON-OFF; ON-OFF

Does 0Y status in maintenance mode indicate presence of flame while unit has been off >5 seconds?

NO

Clean flame rod(s). IF 51 – Error Code appears after cleaning flame rod(s):
Replace flame rod(s).

YES

Replace control board.

On remote control, go to maintenance mode 0Y table.
For maintenance mode instructions go to page 21.

All maintenance mode '0Y' readings should be done immediately after turning the unit OFF.

IF Flame Rod(s) is detecting flame, maintenance mode will display:
Indoor Units: **05**
Outdoor Units: **01**

52 – Error Code

Explanation: PGFR malfunction. The PGFR is the only modulating valve in the gas control valve.

Diagnostics: PGFR (Proportional Gas Flow Regulator)

Turn Power OFF. Remove and reinsert connector “R”. Locate PGFR valve on lower right side of unit (round black piece on bottom of gas control valve). Remove and reinsert Molex connectors with Red and Black wires on PGFR. Operate unit. While viewing through sight glass, determine if flame is visible.

YES

You had a loose connection. Gas control valve is OK. IF 52 – Error Code appears and flame IS visible:

Replace gas control valve.

NO

Continue diagnostics on next page.

Connector Location
on Page 14

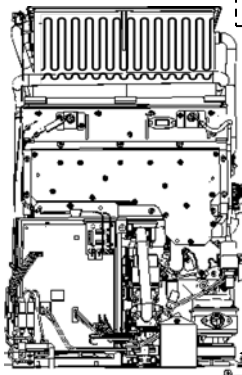

PGFR

While unit is attempting to ignite:
Check DC volts across #1 wire (Red) and #2 wire (Black) on connector "R":

1.5 – 14 DC Volts

NO

Remove & reinsert "R".
Operate unit.
If 52 – Error Code appears:
Replace control board.

YES

While unit is attempting to ignite:
Check DC volts across Red and Black wires at PGFR:

1.5 – 14 DC Volts

NO

Remove & reinsert red and black wires at PGFR.
Retest voltage.
IF NO voltage:
Replace wiring harness for connector "R".

YES

Make sure Black & Red wires are properly connected to PGFR.
Operate unit.
IF 52 - Error Code appears:
Replace gas control valve.

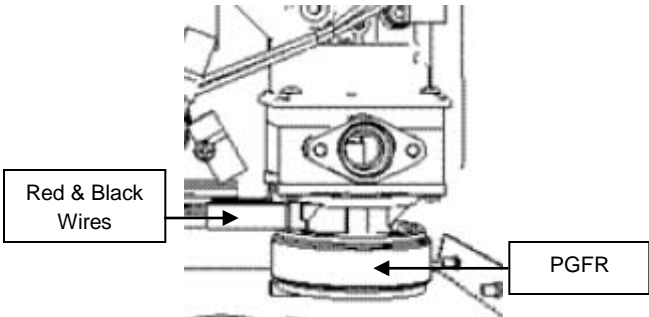

NOTES:

61 – Error Code

Explanation: The Blower motor speed was not appropriate to allow proper combustion.

Diagnostic Checks:

- Blower motor

Turn Power OFF. Remove control board bracket (How to Remove: Section 1).
Remove blower motor (How to Remove: Section 2).
Clean blower motor and blower motor housing.
Reassemble & operate unit.

Does 61 – Error Code appear?

YES

Locate MIN & MAX buttons on upper right-hand corner of control board.

Continue diagnostics on next page.

NO

Unit had a loose connection.

Unit appears to be operating OK.

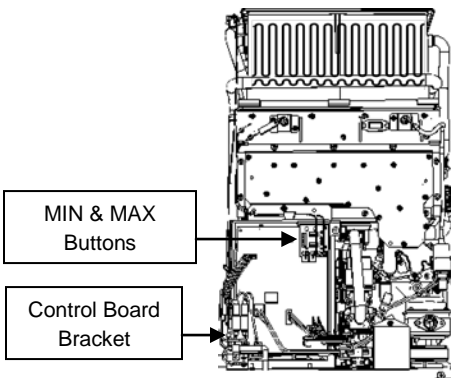

**Blower Motor Diagnostics:
Indoor Models ONLY**

| | | |
|--|--|---|
| <p>Test DC voltage across Black and Red wires on connector "G": 144 – 192 DC Volts</p> | NO | <p>Check connector "G". Operate unit again. IF Code 61 appears: Replace control board.</p> |
| YES | | |
| <p>Hold down MAX button. Test DC voltage across Black & White wires on connector "G": 12 – 18 DC Volts</p> | NO | <p>Check connector "G". Operate unit again. IF Code 61 appears: Replace control board.</p> |
| YES | | |
| <p>Hold down MAX button. Test DC voltage across Black & Blue wires on connector "G": 4 – 10 DC Volts</p> | NO | <p>Check connector "G". Operate unit again. IF Code 61 appears: Replace blower motor.</p> |
| YES | | |
| <p>Control board and blower motor are OK. CHECK GAS SUPPLY & VENTING.</p> | <p>Connector Location on Page 14</p> | |

IMPORTANT: While performing voltage checks, **DO NOT** touch multi-meter leads across **BLUE & WHITE** wires. Damage may occur to blower motor & control board.

Upper Right-Hand Corner of Control Board

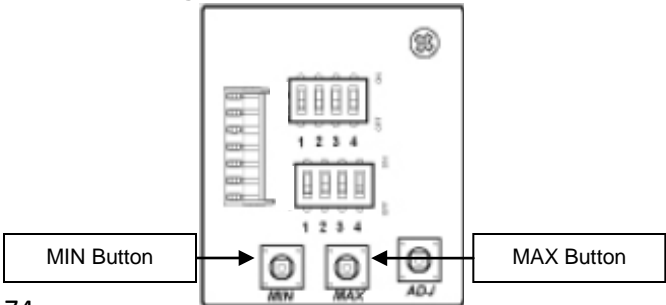

**Blower Motor Diagnostics:
Outdoor Models ONLY**

Test DC voltage across Blue and White wires on connector "G":
144 – 192 DC Volts

NO

Check connector "G".
Operate unit again. IF Code 61 appears:
Replace control board.

YES

Hold down MAX button.
Test DC voltage across Blue & Red wires on connector "G":
12 – 18 DC Volts

NO

Check connector "G".
Operate unit again. IF Code 61 appears:
Replace control board.

YES

Hold down MAX button.
Test DC voltage across Blue & Yellow wires on connector "G":
4 – 10 DC Volts

NO

Check connector "G".
Operate unit again. IF Code 61 appears:
Replace blower motor.

YES

Operate unit. IF 61 – Error Code appears:
Replace control board.

Connector Location on Page 14

IMPORTANT: While performing voltage checks, DO NOT touch multi-meter leads across YELLOW & RED wires. Damage may occur to blower motor & control board.

Upper Right-Hand Corner of Control Board

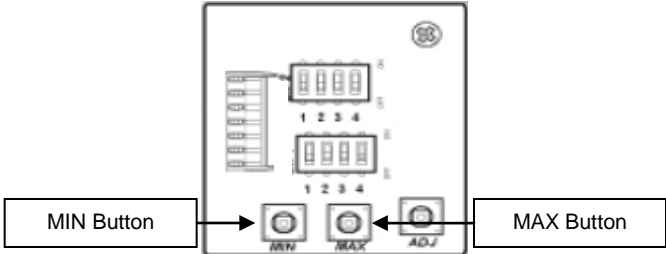

65 – Error Code

Explanation: Water volume control valve malfunction.

IMPORTANT: The water volume control valve will only activate IF demand for hot water EXCEEDS the unit's limitations. If water flow is within the unit's limitations, you will not get a voltage reading for diagnostics.

HINT: Turn on all hot water fixtures to activate water volume control valve (refer to 29 – Error Code (B) page 56).

Diagnostic Checks:

- Water volume control valve

Turn Power OFF; remove and reinsert connector "C". Remove control board bracket (How to Remove: Section 1). Visually inspect water volume control valve for loose or damaged connections. Reassemble & operate unit.

Does 65 – Error Code appear?

YES

Continue diagnostics on next page.

NO

Unit had a loose connection.

Unit appears to be operating OK.

Connector Location on Page 14

Blower Motor

Water volume control valve; located to right of blower motor; connected directly to water inlet.

While water is flowing & unit is attempting to ignite; check DC volts across White & Black wires at connector "C":

8 – 16 DC Volts

NO

Check connector "C". Operate unit again. IF code 65 appears:

Replace control board.

YES

Turn Power OFF then ON. While water is flowing & unit is attempting to ignite; check DC volts across Red & Black wires at connector "C":

8 – 16 DC Volts

NO

Check connector "C". Operate unit again. IF code 65 appears:

Replace control board.

YES

Turn Power OFF then ON. While water is flowing & unit is attempting to ignite; check DC volts across Green & Black wires at connector "C":

4 – 6 DC Volts

NO

Check connector "C". Operate unit again. IF code 65 appears:

Replace control board.

YES

Operate unit. IF 65 – Error Code appears:

Replace water volume control valve.

HINT: If voltages are NOT registering, ATTEMPT to activate water volume control valve by turning remote control to highest temperature setting & opening all hot water fixtures.

CAUTION: Hot water temperatures above 120 will scald. Return to original setting once test is complete.

9 times out of 10, the WCV is at fault. Very difficult to get the above voltages to appear.

66 – Error Code

Explanation: Water by-pass valve malfunction.
IMPORTANT: Prior to measuring voltage, turn remote control temperature down to 102 degrees. Water bypass valve will activate at this temperature setting.

Diagnostic Checks:

- Water bypass valve

Connector Location
on Page 14

Turn Power OFF. Remove and reinsert connector "B". Remove control board bracket (How to Remove: Section 1). Visually inspect water bypass valve for loose or damaged connections. Reassemble & operate unit.

Does 66 – Error Code appear?

NO

Unit had a loose connection.

Unit appears to be operating OK.

YES

Turn remote control OFF; unplug unit. Plug unit in. Turn Power ON. Operate unit. Check DC volts across Red & Black wires at connector "B":

8 – 16 DC Volts

NO

Check connector "B". Operate unit again. IF 66 – Error Code appears:

Replace control board.

YES

Operate unit. IF 66 – Error Code appears:

Replace water bypass valve.

For water bypass valve location: Refer to 65 - Error Code diagram. Water bypass valve is located right of blower motor; connected directly to bottom of two copper pipes.

71 – Error Code

Explanation: Gas control valve malfunction (inlet solenoid).

Diagnostic Checks:

- Gas control valve

Turn Power OFF.
Remove and reinsert connector "K".
Operate unit.
Does 71 – Error Code appear?

NO

Unit had a loose connection.

Unit appears to be operating OK.

YES

While unit is attempting to ignite; check DC voltage across Yellow & black wires on connector "K":

90 – 120 DC Volts

NO

Check connector "K".
Operate unit.
IF 71–Error Code appears:

Replace control board.

YES

Operate unit.
IF 71–Error Code appears:
Replace gas control valve.

Connector Location on Page 14

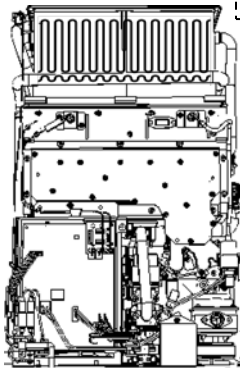

Gas Control Valve

NOTES:

72 – Error Code

Explanation: Flame rod(s) malfunction. Flame rod(s) is detecting the presence of flame BEFORE igniter is activated.

Diagnostic Checks:

- Flame rod(s)
- Gas control valve

Connector Location
on Page 14

Turn Power OFF. Remove and reinsert connector ‘M’, ‘T’, & terminal on flame rod(s). Turn Power ON and operate unit. Did 72 – Error Code appear?

Indoor models – 2 flame rods (Connectors “M” & “T”).

Outdoor models – 1 flame rod (Connector “M”).

YES

NO

Access maintenance mode to check flame rod status. Locate sight glass.

Continue to diagnostic chart on next page.

Unit had a loose connection or foreign debris that is no longer present.

Unit appears to be operating OK.

(See maintenance mode instructions on page 21)

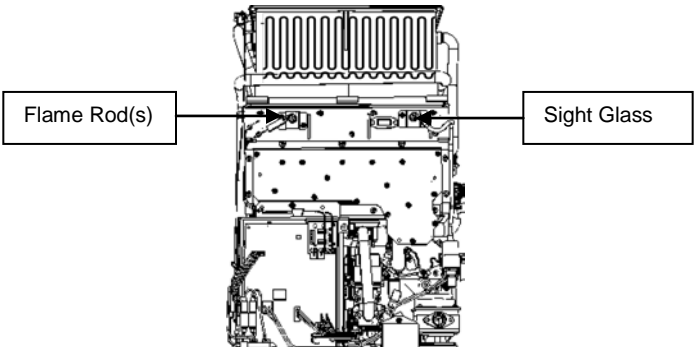

Turn Power OFF. Unplug unit and plug back in. Turn Power ON. While viewing through sight glass, turn on water flow to begin ignition sequence. Is flame visible before igniter sparks?

NO

Follow maintenance mode instructions at bottom of page & continue to diagnostics on next page.

YES

Visually inspect burner chamber through sight glass for foreign debris.

NO

Operate unit again. IF 72 – Error Code appears & flame IS visible before igniter rod sparks:

Replace gas control valve.

YES

Remove & clean burner assembly.

Outdoor: 1 flame rod

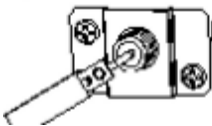

Indoor: 2 flame rods

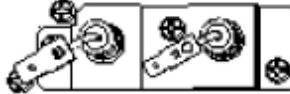

On remote control, go to maintenance mode 0Y table. For maintenance mode instructions go to page 21.

All maintenance mode '0Y' readings should be done immediately after turning the unit ON. IF Flame Rod(s) is detecting flame, maintenance mode will display:

Indoor Units: **05**
Outdoor Units: **01**

Operate unit. Does 0Y status in maintenance mode indicate presence of flame BEFORE igniter rod sparks?

NO

Unit appears to be OK. Operate unit. IF 72 – Error Code appears:

Replace control board.

YES

Turn Power OFF. Unplug unit. Disconnect wires at flame rod(s). Plug unit in. Turn Power ON. Operate unit. Does 0Y status in maintenance mode indicate presence of flame BEFORE igniter rod sparks?

NO

Clean flame rod(s). IF 72 – Error Code appears after cleaning flame rod(s):

Replace flame rod(s).

YES

Replace control board.

On remote control, go to maintenance mode 0Y table. For maintenance mode instructions go to page 21.

All maintenance mode '0Y' readings should be done immediately after turning the unit ON. IF Flame Rod(s) is detecting flame, maintenance mode will display:

Indoor Units: **05**
Outdoor Units: **01**

76 – Error Code

Explanation: Communication fault with remote control. Remote control is not communicating with control board.

Diagnostic Checks:

- Remote control

Visually inspect remote control wiring for damaged or loose connections. Is wiring OK?

NO

Tighten loose connections or replace damaged wiring.

YES

Unplug unit and remove remote control wires from bottom of unit. Plug unit in and operate. Did unit go to main burner?

NO

Replace control board.

YES

Unplug unit. Use a new short piece of wire to connect remote control directly to wiring terminals at bottom of unit. Plug unit in, turn power ON and operate. Does 76 – Error Code appear?

NO

Replace remote control wiring.

YES

Replace remote control.

79 – Error Code

Explanation: Blower motor current fault.

Diagnostic Checks:

- Blower motor

Turn Power OFF. Remove control board bracket (How to Remove: Section 1).
Remove blower motor (How to Remove: Section 2).
Clean blower motor and blower motor housing.
Reassemble & operate unit.

Does 79 – Error Code appear?

YES

Locate MIN & MAX buttons on upper right-hand corner of control board

Continue diagnostics on next page.

NO

Unit had a loose connection.

Unit appears to be operating OK.

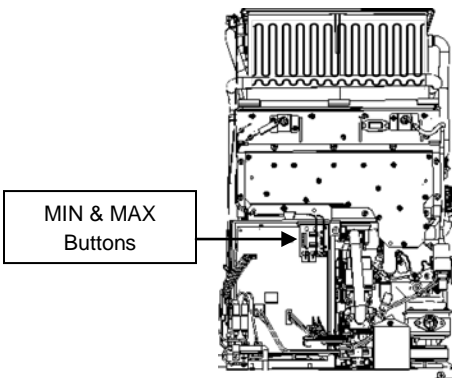

**Blower Motor Diagnostics:
Indoor Models ONLY**

| | | |
|---|----------------------------------|--|
| Test DC voltage across Black and Red wires on connector "G": 144 – 192 DC Volts | NO | Check connector "G". Operate unit again. IF code 79 appears: Replace control board. |
| YES | | |
| Hold down MAX button. Test DC voltage across Black & White wires on connector "G": 12 – 18 DC Volts | NO | Check connector "G". Operate unit again. IF code 79 appears: Replace control board. |
| YES | | |
| Hold down MAX button. Test DC voltage across Black & Blue wires on connector "G": 4 – 10 DC Volts | NO | Check connector "G". Operate unit again. IF code 79 appears: Replace blower motor. |
| YES | | |
| Control board and blower motor are OK. CHECK GAS SUPPLY & VENTING. | Connector Location on Page 14 | |

IMPORTANT: While performing voltage checks, **DO NOT** touch multi-meter leads across **BLUE & WHITE** wires. Damage may occur to blower motor & control board.

Upper Right-Hand Corner of Control Board

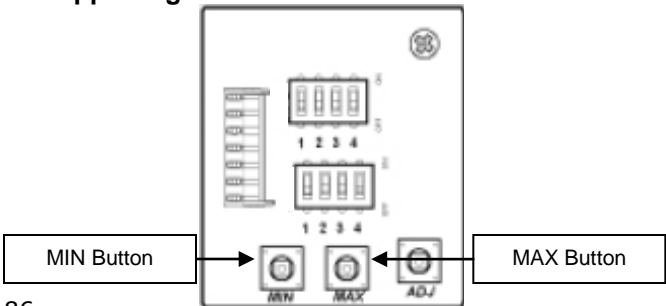

**Blower Motor Diagnostics:
Outdoor Models ONLY**

Test DC voltage across Blue and White wires on connector "G":
144 – 192 DC Volts

NO

Check connector "G".
Operate unit again.
IF Code 79 appears:
Replace control board.

YES

Hold down MAX button.
Test DC voltage across Blue & Red wires on connector "G":
12 – 18 DC Volts

NO

Check connector "G".
Operate unit again.
IF 79 – Error Code appears:
Replace control board.

YES

Hold down MAX button.
Test DC voltage across Blue & Yellow wires on connector "G":
4 – 10 DC Volts

NO

Check connector "G".
Operate unit again.
IF 79 – Error Code appears:
Replace blower motor.

YES

Operate unit. IF 79 – Error Code appears:
Replace control board.

Connector Location
on Page 14

IMPORTANT: While performing voltage checks, DO NOT touch multi-meter leads across YELLOW & RED wires. Damage may occur to blower motor & control board.

Upper-Right Hand Corner of Control Board

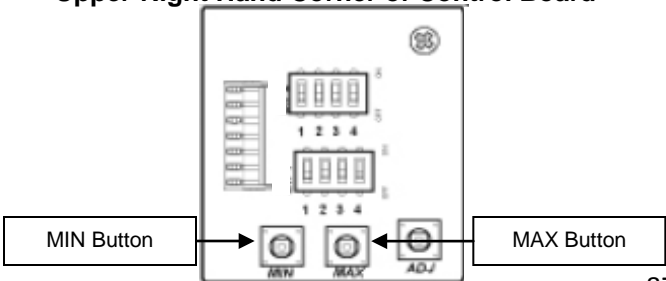

80 – Error Code

Explanation: Gas control valve malfunction. Unit detected the presence of flame when demand for hot water terminated & the unit turned OFF.

Diagnostic Checks:

- Flame rod(s)
- Gas control valve

Connector Location
on Page 14

Turn Power OFF. Remove and reinsert connector 'M', 'T', & terminal on flame rod(s).
Turn Power ON and operate unit.
Does 80 – Error Code appear?

Indoor models – 2 flame rods (Connectors "M" & "T").
Outdoor models – 1 flame rod (Connector "M").

YES

Access maintenance mode to check flame rod status.
Locate sight glass.

Continue to diagnostic chart on next page.

NO

Unit had a loose connection or foreign debris that is no longer present.

Unit appears to be operating OK.

(See maintenance mode instructions on page 21)

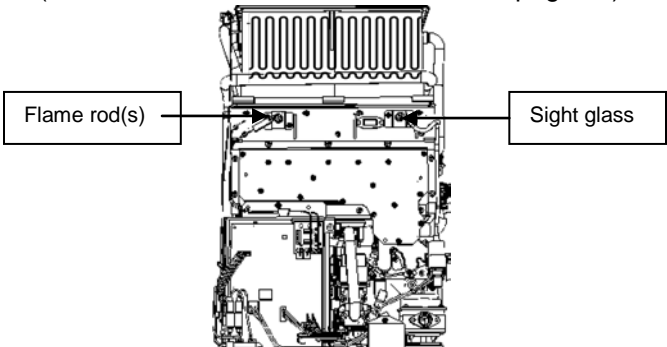

While viewing burner chamber through sight glass: In 10 second intervals; cycle unit 3 times to determine IF flame is visible when OFF:
ON-OFF; ON-OFF; ON-OFF

NO

Follow maintenance mode instructions at bottom of page & continue to diagnostics on next page.

YES

Visually inspect burner chamber through sight glass for foreign debris.

NO

Operate unit. IF 80 – Error Code appears & flame IS visible while unit has been OFF for longer than 5 seconds:

Replace gas control valve.

YES

Remove & clean burner assembly.

HINT: Open a hot water fixture & use water shut off valve at the unit to cycle unit "ON-OFF".

Outdoor: 1 flame rod



Indoor: 2 flame rods

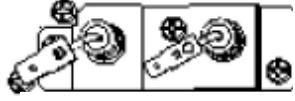

On remote control, go to maintenance mode 0Y table. For maintenance mode instructions go to page 21.

All maintenance mode '0Y' readings should be done immediately after turning the unit OFF. IF flame rod(s) is detecting flame, maintenance mode will display:

Indoor Units: **05**
Outdoor Units: **01**

In 10 second intervals;
cycle unit 3 times by
turning unit:

ON-OFF; ON-OFF; ON-OFF

Does 0Y status in
maintenance mode
indicate presence of
flame after 5 seconds?

NO

Unit appears to be OK.
Operate unit.
IF 80 – Error Code
appears:

Replace control board.

YES

Disconnect wires at
flame rod(s). While
viewing burner chamber
through sight glass: In
10 second intervals;
cycle unit 3 times:

ON-OFF; ON-OFF; ON-OFF

Does 0Y status in
maintenance mode
indicate presence of
flame after 5 seconds?

NO

Clean flame rod(s). IF
80 – Error Code appears
after cleaning flame
rod(s):

Replace flame rod(s).

YES

Replace control board.

On remote control, go to maintenance mode 0Y table.
For maintenance mode instructions go to page 21.

All maintenance mode '0Y' readings should be done immediately
after turning the unit OFF.

IF Flame Rod(s) is detecting flame, maintenance mode will
display:
Indoor Units: **05**
Outdoor Units: **01**

82 – Error Code

Explanation: Control board program chip malfunction.

Diagnostic Checks:

- Program chip

Turn Power OFF. Verify correct program chip is installed.

YES

Remove and reinsert program chip.
Operate unit.
IF 82 – Error Code appears:

Replace program chip.

NO

Insert correct program chip.

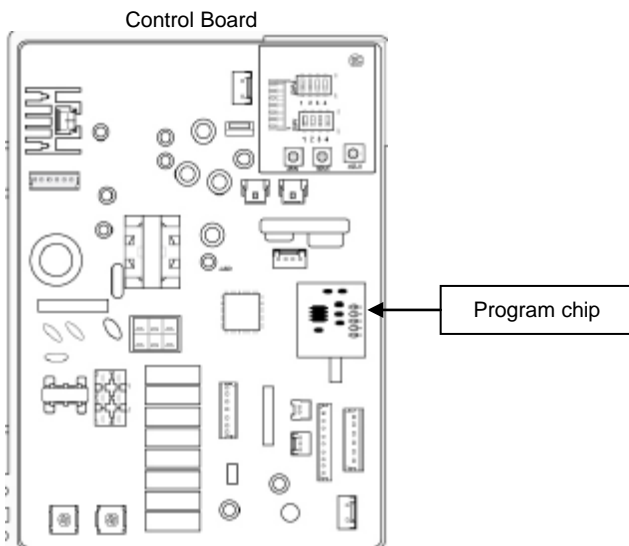

90 & 99 – Error Code

Explanation: Unit was operated prior to vent installation OR unit detected blockage in the venting during pre-purge OR post-purge cycle.

90 – Error Code will occur BEFORE unit goes to ignition.

99 – Error Code will occur AFTER unit shuts down.

Unit must be reset by performing reset procedure on page 26.

Diagnostic Checks:

- **Perform reset procedure on page 26**
- **VENTING – refer to pages 8-11** or refer to Use & Care manual for installation instructions:
 1. Approved vent materials
 2. Approved terminations
 3. Approved vent lengths
 4. Location and distance between venting (recirculation of exhaust)
 5. Blocked venting
 6. Venting not sealed properly (recirculation of exhaust)

92 & 93 – Error Code

Explanation: High-Efficiency (condensing) Units ONLY:

92 – Error Code: This is a warning code and unit will continue to operate but will eventually shut down.

REPLACE NEUTRALIZER ASAP

Neutralizer rocks made from Calcium Carbonate (CACO₃)
Neutralizer kit may be ordered through Rheem/Ruud
Supplier.

93 – Error Code: Unit will NOT operate until the Neutralizer is replaced.

REPLACE NEUTRALIZER IMMEDIATELY

Neutralizer rocks made from Calcium Carbonate (CACO₃)
Neutralizer kit may be ordered through Rheem/Ruud
Supplier.

UNIT MUST BE RESET AFTER NEUTRALIZER IS REPLACED

With remote control ON and no water is running through unit: Push MIN & MAX buttons at same time – CL is displayed on remote control. Push MIN & MAX buttons again for more than 5 seconds – CL disappears.

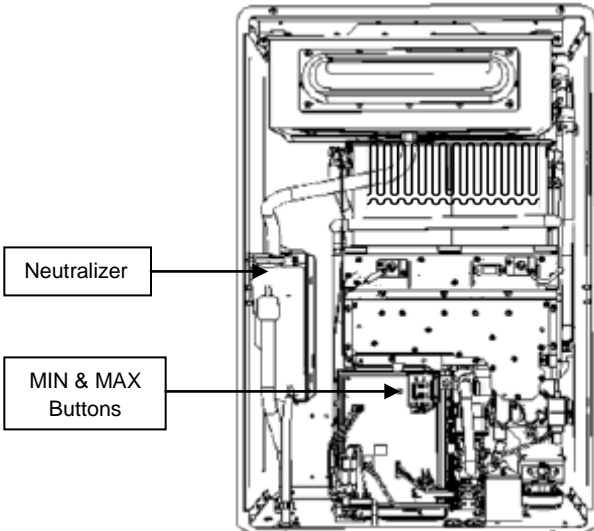

NOTES:

HOW TO REMOVE COMPONENTS

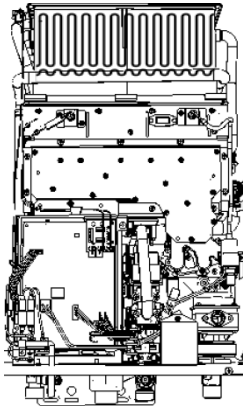

Section 1: Control Board Bracket

ALWAYS TURN OFF Power, Water & Gas

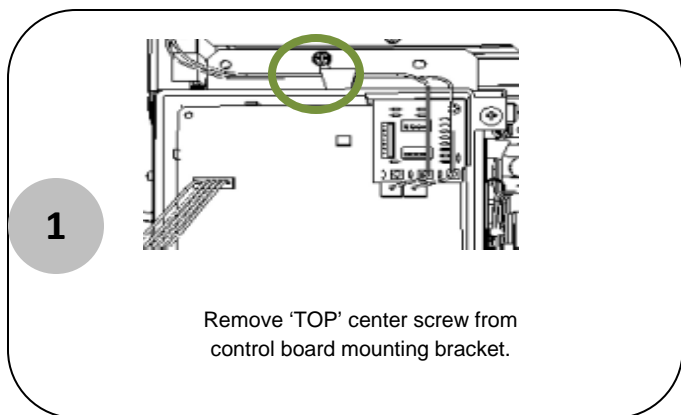
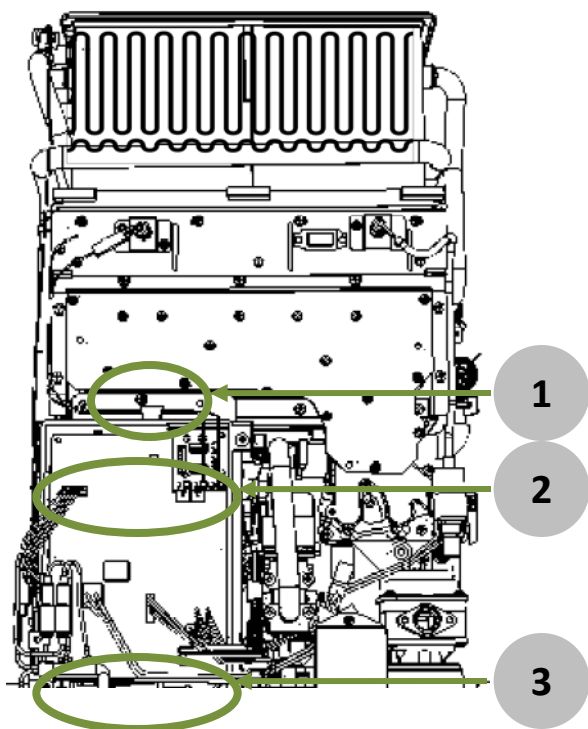

Remove 'TOP' center screw from control board mounting bracket.

2

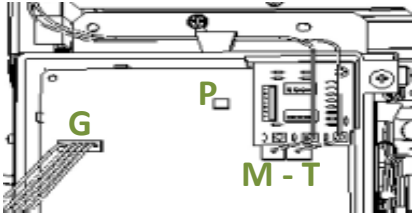

Remove connectors: 'M'; 'T'; & 'G'.
Condensing ONLY: ALSO remove connector 'P'.

The diagram shows a close-up of the control board area. A green circle highlights a connector labeled 'G'. Another green circle highlights a connector labeled 'P'. A third green circle highlights a connector labeled 'M-T'. The diagram is enclosed in a rounded rectangular frame.

3

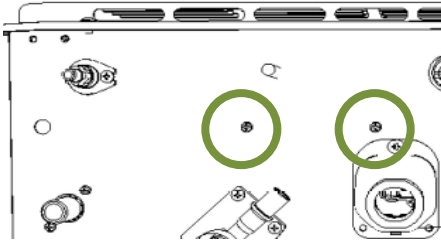

*Remove 2 control board bracket screws located on bottom, outer shell of unit.
*Pull control board bracket out of way to access components.

The diagram shows the bottom of the unit's outer shell. Two screws on the control board bracket are circled in green. The diagram is enclosed in a rounded rectangular frame.

Section 2: Blower Motor

ALWAYS TURN OFF Power, Water & Gas

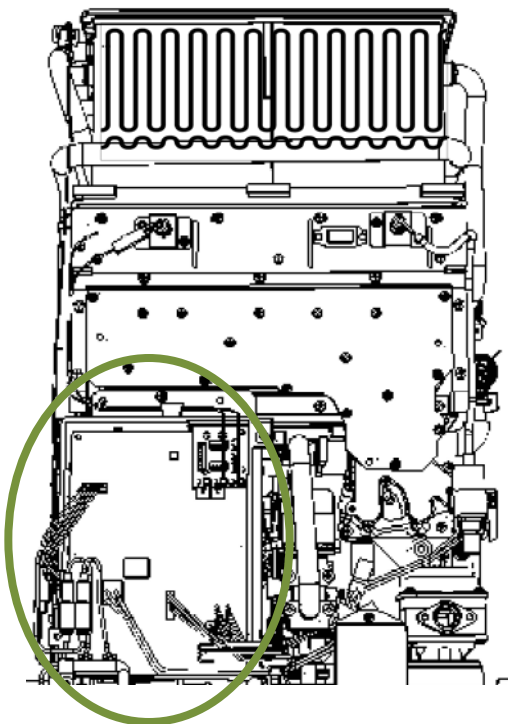

Remove control board Bracket to access Blower Motor

Section 1

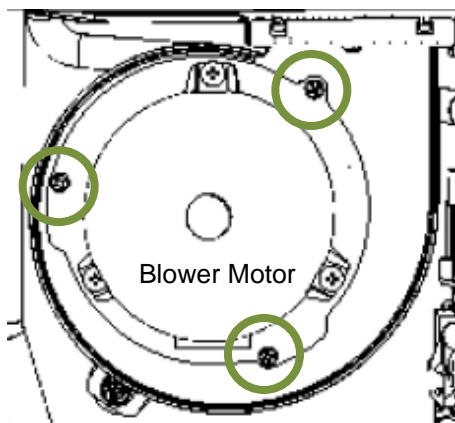

*Move control board bracket out of way to access blower motor (follow instructions in Section 1).

*Remove 3 OUTER screws from blower motor assembly (circled in green).

*Pull blower motor out of housing.

Section 3: Igniter Rod-Flame Rod-Igniter Coil ALWAYS TURN OFF Power, Water & Gas

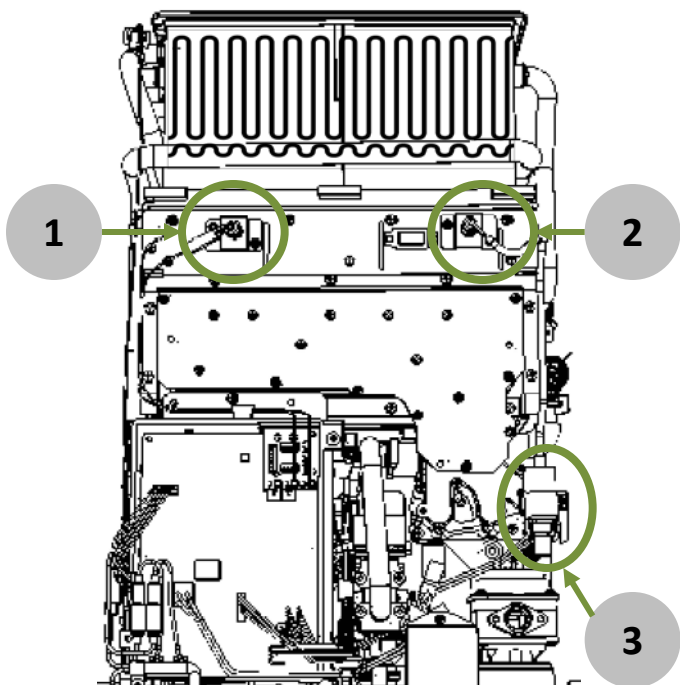

| Outdoor | Indoor |
|--|--------|
| | |
| <p>Flame Rod(s)</p> | |
| <p>1</p> <ul style="list-style-type: none"> *Disconnect flame rod wire(s). *Remove flame rod mounting screws. *Pull flame rod(s) out. <p>IMPORTANT: During reassembly - make sure flame rod gasket is in place.</p> | |

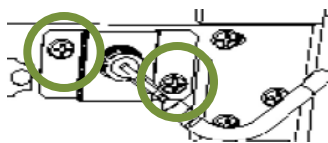

Igniter Rod

2

- *Disconnect black igniter cable from igniter rod.
- *Remove igniter rod mounting screws.
- *Pull igniter out.

IMPORTANT: During reassembly - make sure igniter rod gasket is in place.

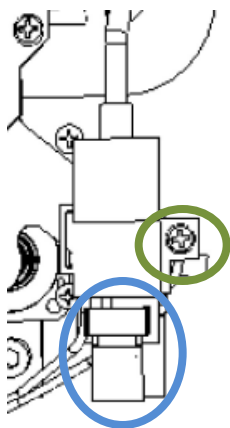

Igniter Coil

3

- *Disconnect black igniter cable from igniter rod.
- *Remove igniter coil mounting screw.
- *Disconnect white Molex from igniter coil (circled in blue – has 2 grey wires).

Section 4: Manifold Assembly

ALWAYS TURN OFF Power, Water & Gas

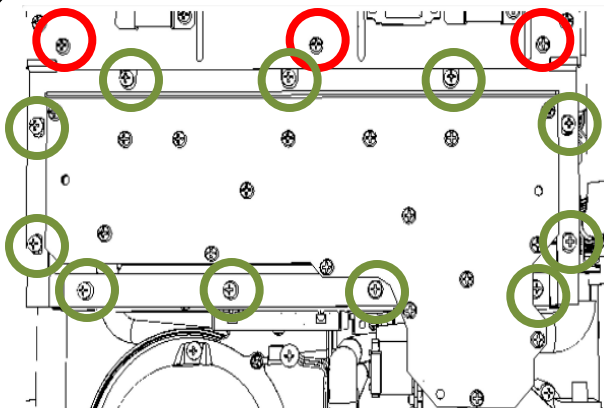
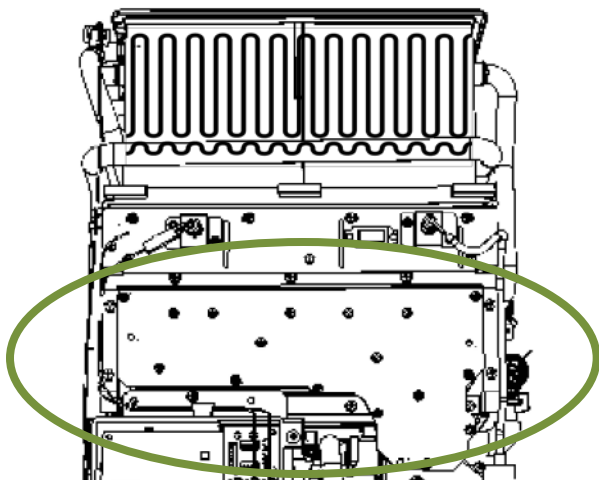

*Move control board bracket out of way (follow instructions in Section 1).

*Remove 11 screws from upper manifold assembly (circled in green).

IMPORTANT: NEVER REMOVE 3 screws directly above manifold assembly (CIRCLED IN RED).

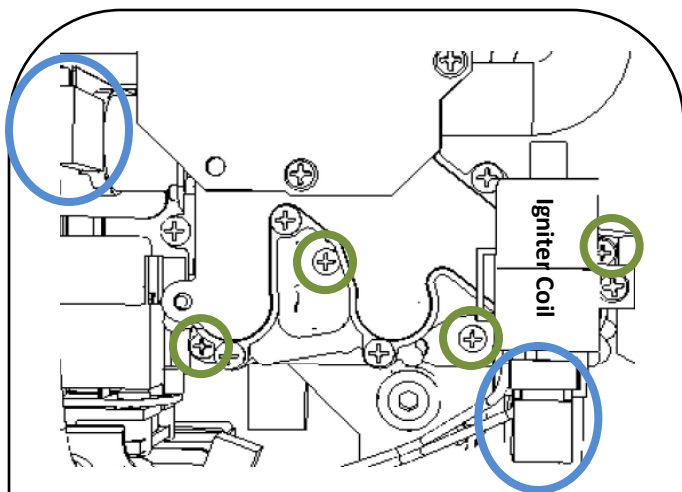

*Remove 4 screws from lower manifold assembly (circled in green).

*Disconnect black igniter coil cable from igniter rod.

*Disconnect white Molex from bottom of igniter coil (circled in blue – has 2 grey wires).

*Disconnect white Molex from solenoid on left (circled in blue – has 2 black wires and 1 grey wire).

*Pull orifice assembly out.

NOTICE: All 4 screws are located at bottom of aluminum casing. It is not necessary to remove upper screws.

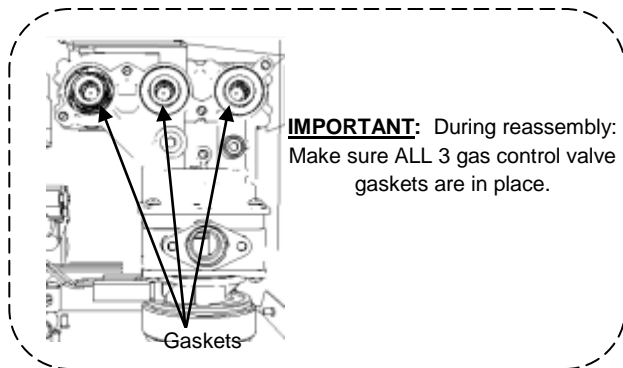

IMPORTANT: During reassembly: Make sure ALL 3 gas control valve gaskets are in place.

Section 5: Burner Assembly

ALWAYS TURN OFF Power, Water & Gas

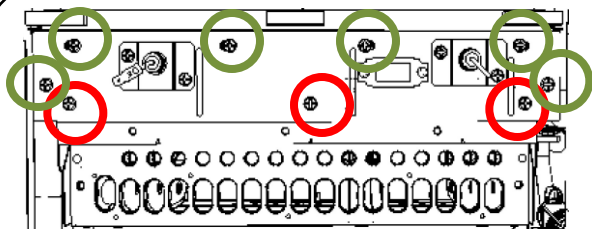
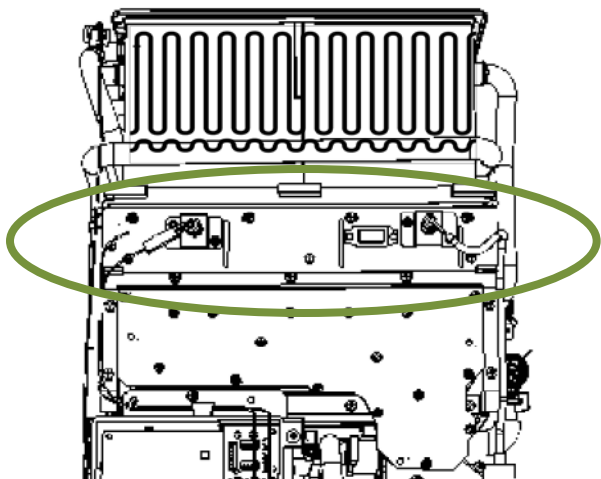

- *Move control board bracket out of way (follow instructions in Section 1).
- *Remove manifold assembly (follow instructions in Section 4).
- *Remove 6 screws from burner assembly (circled in green).
- *Pull burner assembly out of heat exchanger housing.

IMPORTANT: NEVER REMOVE 3 bottom screws on burner assembly (CIRCLED IN RED).

IMPORTANT: Orifice assembly and burner assembly screws are different size and type. ALWAYS keep them separate.

Section 6: Gas Control Valve

ALWAYS TURN OFF Power, Water & Gas

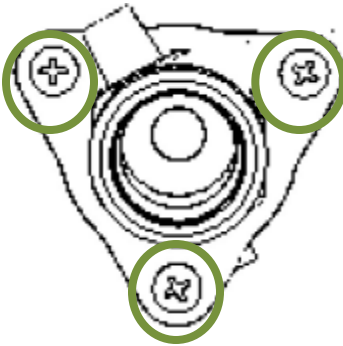
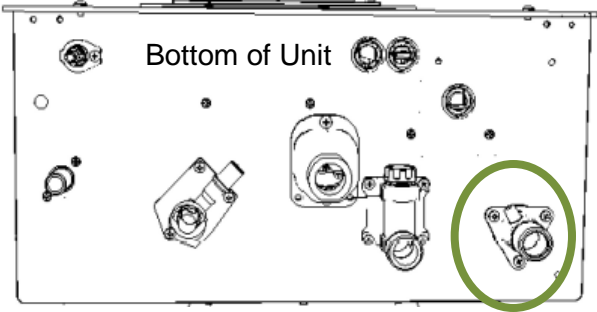

*Move control board bracket out of way
(follow instructions in Section 1).

*Remove Manifold Assembly
(follow instructions in Section 4).

*Remove 3 screws for gas inlet connection
located at bottom of unit.

*Remove gas inlet connection.

(Continue to next page)

Section 6: Gas Control Valve

ALWAYS TURN OFF Power, Water & Gas

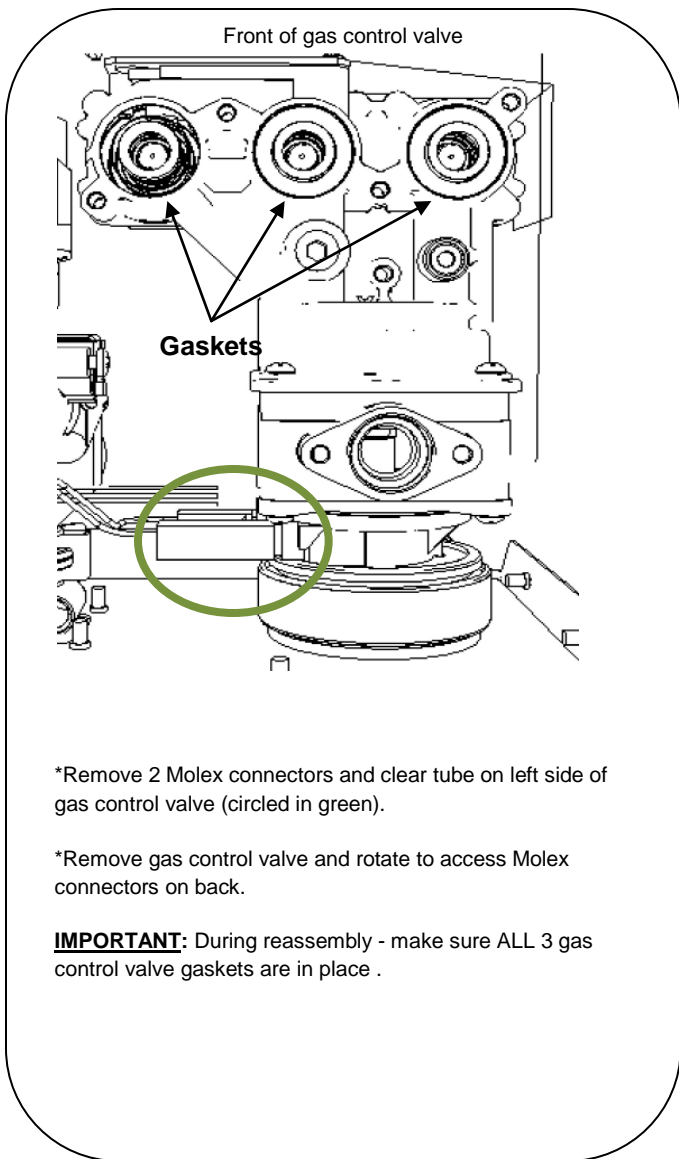

*Remove 2 Molex connectors and clear tube on left side of gas control valve (circled in green).

*Remove gas control valve and rotate to access Molex connectors on back.

IMPORTANT: During reassembly - make sure ALL 3 gas control valve gaskets are in place .

Back view of gas control valve

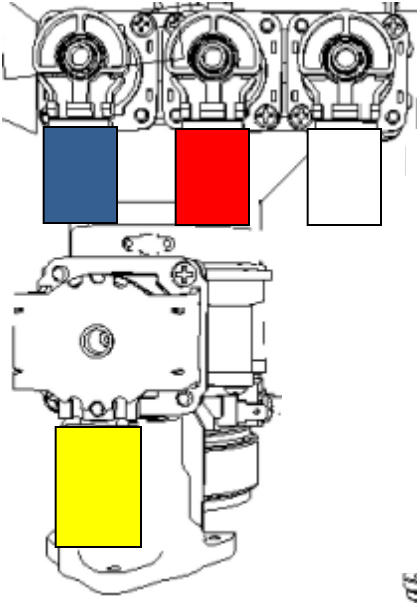

*Remove 4 Molex connectors on back of gas control valve (highlighted in corresponding wire color).

*Remove gas control valve.

Front view of gas control valve

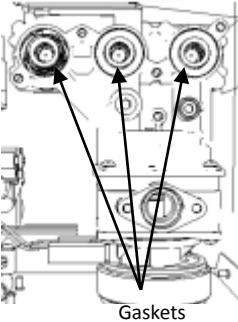

IMPORTANT: During reassembly: Make sure ALL 3 gas control valve gaskets are in place.

NOTES:

**Section 7: Water Volume Control &
Water Bypass Valves**
ALWAYS TURN OFF Power, Water & Gas
Use Service Valves to DRAIN UNIT

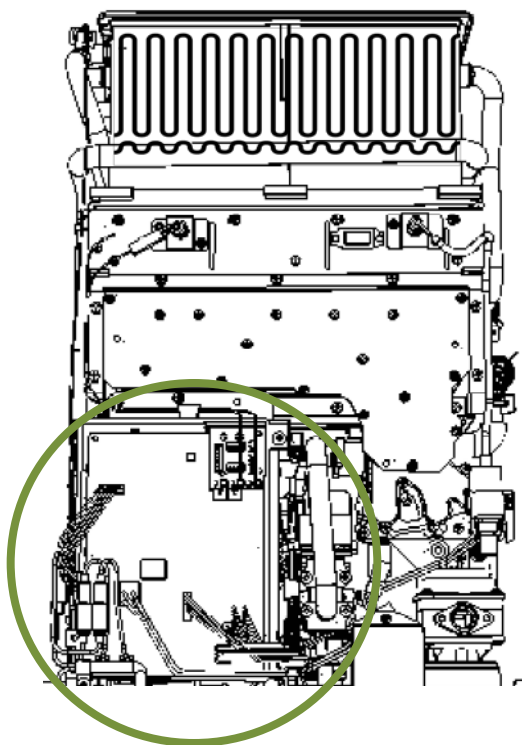

Remove control board Bracket to access water control valves.

Section 1

(Continue to next page)

**Section 7: Water Volume Control &
Water Bypass Valves**
ALWAYS TURN OFF Power, Water & Gas
Use Service Valves to DRAIN UNIT

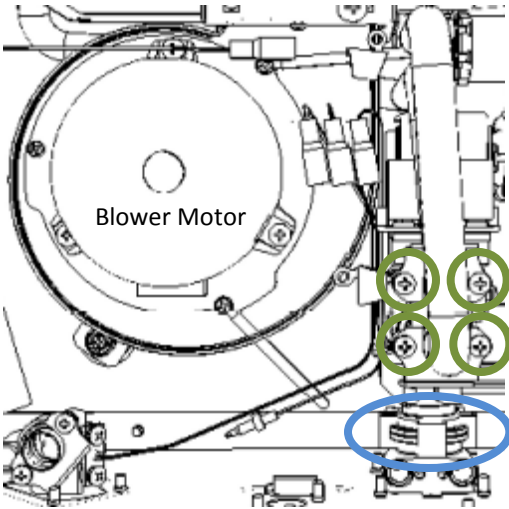

- *Remove 4 screws holding compression fittings in place & remove metal tabs.
- *Pull copper pipes out to separate from water valves (1 o-ring on each pipe).
- *Remove snap ring (circled in blue).
- *Push water volume control towards top of unit to separate from water inlet (1 o-ring).
- *Remove water volume control & water bypass valve assembly.

IMPORTANT: During reassembly – make sure ALL O-Rings are on MALE fittings. This will prevent pinching or rolling the O-Rings.

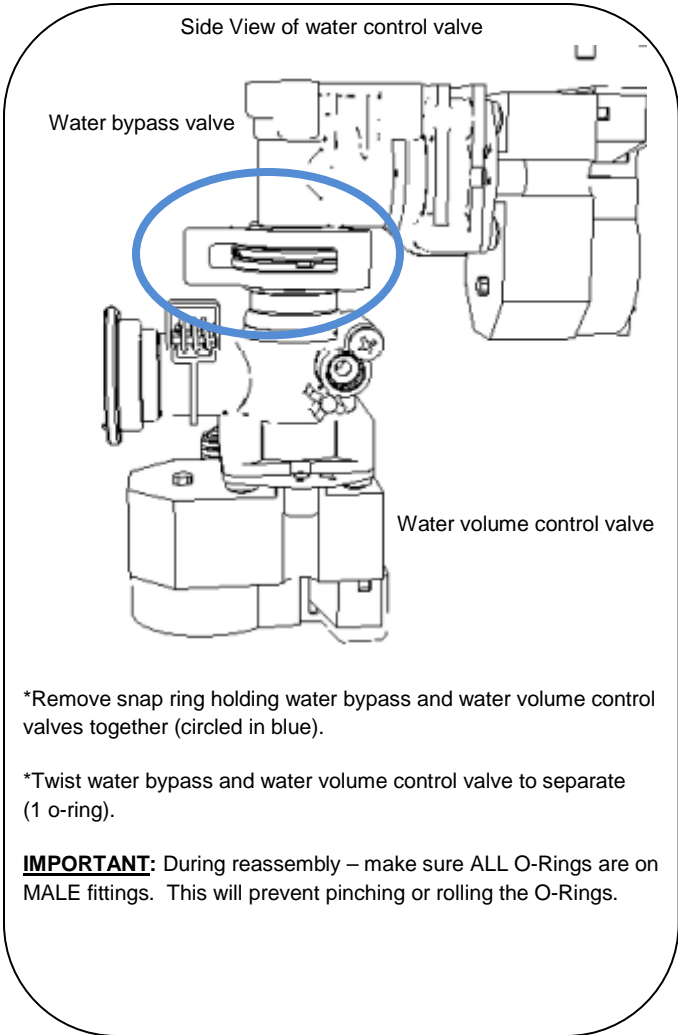

Section 8: Heat Exchanger thermistors
ALWAYS TURN OFF Power, Water & Gas
Use Service Valves to DRAIN UNIT

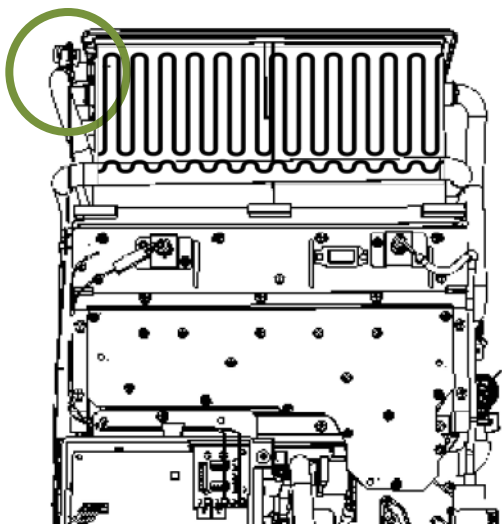

1

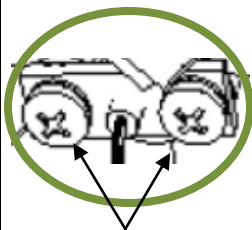

*Remove 2 screws



OR

Remove snap ring

*Pull Heat Exchanger thermistor out
(O-ring should remain in thermistor well).

NOTE: thermistor has white wire.

To REPLACE thermistor go to diagram 2

2

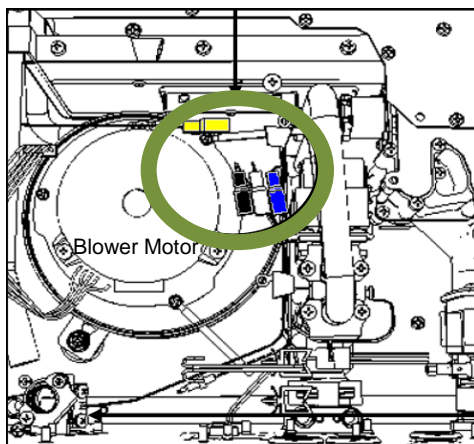

*Move control board bracket out of way to access Molex for Heat Exchanger thermistor (follow instructions in Section 1).

NOTE: Mid-Efficiency – YELLOW Molex
High-Efficiency (Condensing) – GREEN Molex

*Separate Molex and remove Heat Exchanger thermistor – thermistor is attached to female end of Molex (white wire).

Section 9: Outlet thermistor
ALWAYS TURN OFF Power, Water & Gas
Use Service Valves to DRAIN UNIT

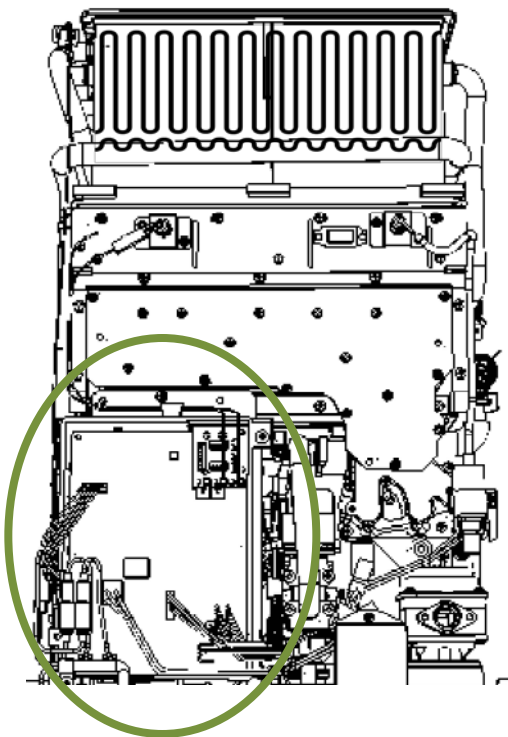

Remove control board Bracket to access
outlet thermistor.

Section 1

1

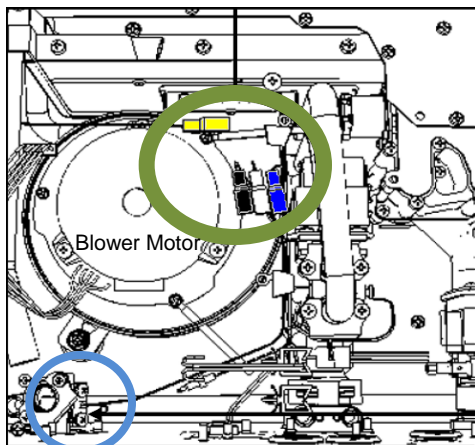

*Move control board bracket out of way to access outlet thermistor (follow instructions in Section 1).

*Locate Outlet thermistor on lower left side of unit (circled in blue).

*To REPLACE thermistor ONLY: Separate BLACK Molex (circled in green) – thermistor is attached to female end of Molex (black wire).

2

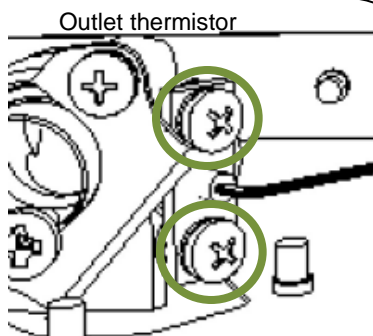

*Remove 2 screws

*Remove Outlet thermistor
(O-ring should remain in thermistor well)

Section 10: Inlet thermistor
ALWAYS TURN OFF Power, Water & Gas
Use Service Valves to DRAIN UNIT

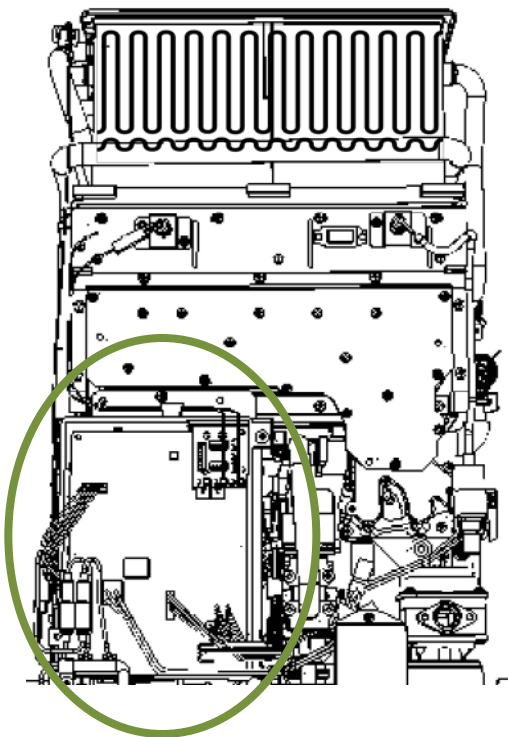

Remove control board Bracket to access inlet thermistor.

Section 1

1

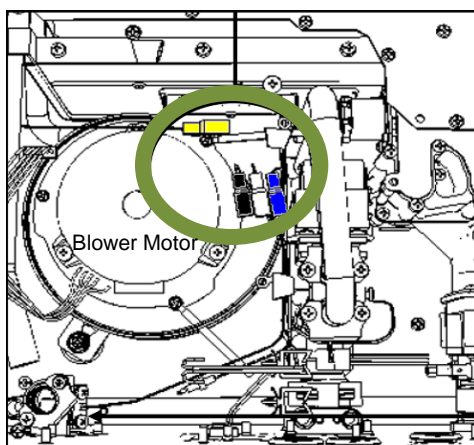

*Move control board bracket out of way to access WHITE Molex for inlet thermistor (follow instructions in Section 1).

* To REPLACE thermistor ONLY: Separate WHITE Molex (circled in green). Thermistor is attached to female end of Molex (white wire).

Water Volume Control Valve

2

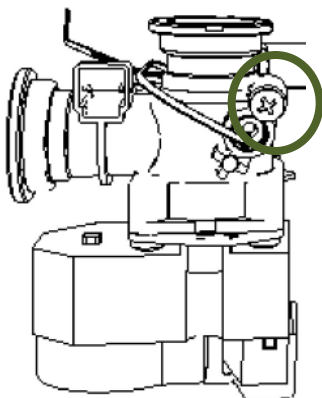

*Remove Water Bypass & Water Volume valves (follow instructions in Section 7).

*Remove single screw for the inlet thermistor.

*Remove Inlet thermistor (O-ring should remain in thermistor well).

Section 11: Ambient thermistor

ALWAYS TURN OFF Power, Water & Gas

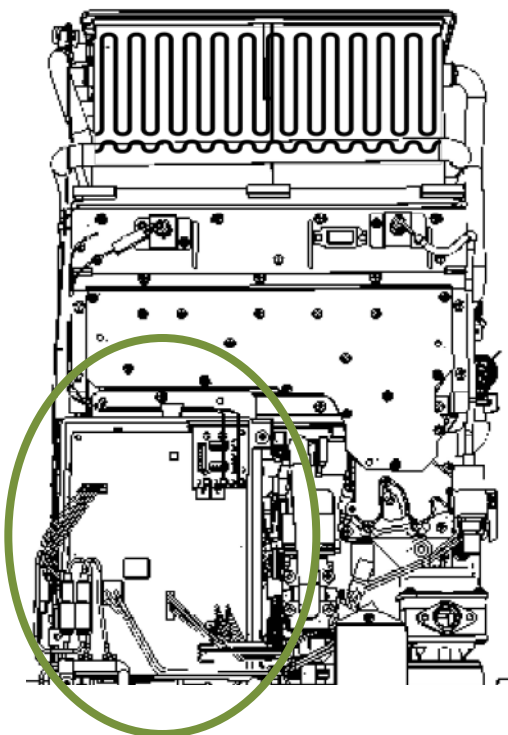

Remove control board Bracket to diagnose and/or replace ambient thermistor.

Section 1

1

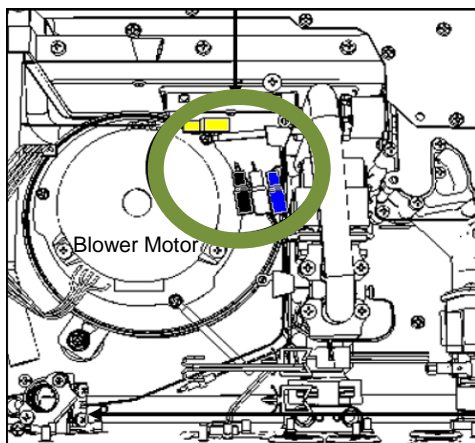

To REPLACE thermistor ONLY:

*Move control board bracket out of way to access BLUE Molex for ambient thermistor (follow instructions in Section 1).

*Separate BLUE Molex (circled in green) – thermistor is attached to female end of Molex (black wire).

2

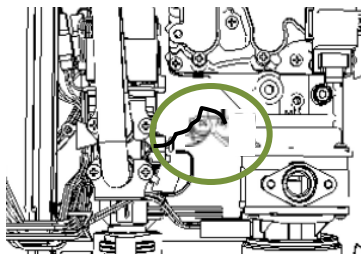

Mid Efficiency Indoor Units

*Remove single screw for the ambient thermistor (located on back of unit - left of gas control valve– black wire).

*Remove ambient thermistor.

All Outdoor & High Efficiency (condensing) Units ONLY:

*Ambient thermistor is located behind the control board near the blower motor (not fastened – black tear drop).

*To Locate thermistor: Follow black wire on female end of BLUE Molex.

Section 12: Control Board

ALWAYS TURN OFF Power, Water & Gas

- *Remove ALL Molex connections on control board.
- *Remove line voltage screws (black & white wires).
- *Remove top right mounting screw.
- *Remove Fuel Type Chip.

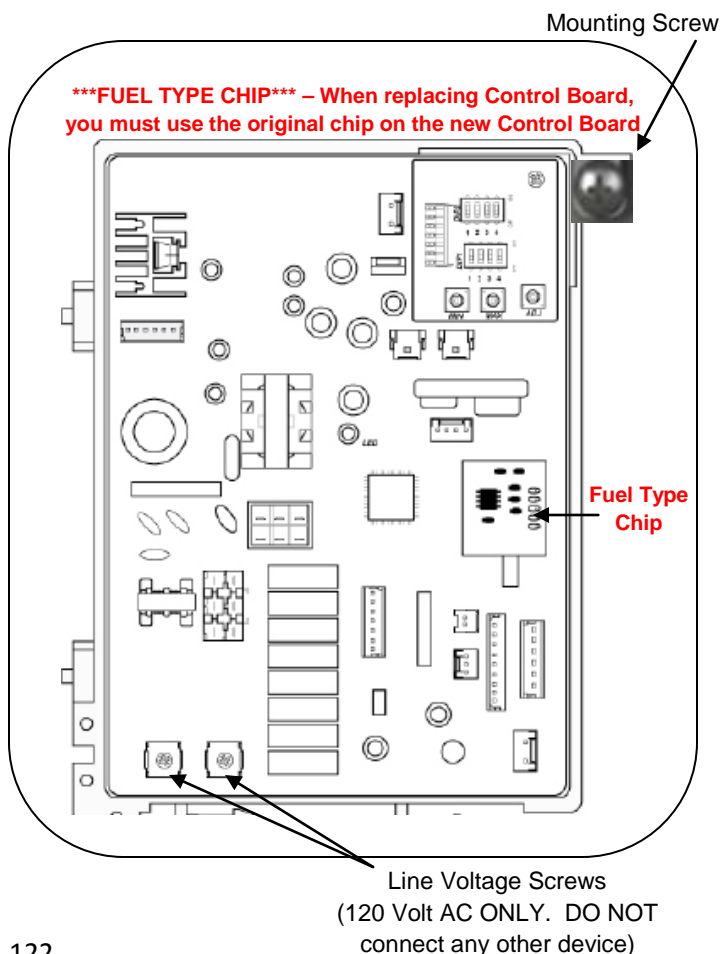

Section 12: Control Board Replacement Procedure

Recording Manifold Pressure on ORIGINAL Control Board

NOTE: Without this adjustment the water heater may not function properly. (HINT: IF manifold pressure settings are written on the Manifold Assembly, you may skip to next page)

Verify "MINIMUM" Manifold Pressure Setting on Original Control Board

1. The setting value will display on the remote control.
 2. Push and hold down the ADJ button.
 3. While holding the ADJ button, push the MIN button.
 4. Record the number displayed on Remote: _____
 5. Release the ADJ button.
-

Verify "MAXIMUM" Manifold Pressure Setting on Original Control Board

1. The setting value will display on the remote control.
 2. Push and hold down the ADJ button.
 3. While holding the ADJ button, push the MAX button.
 4. Record the number displayed on Remote: _____
 5. Release the ADJ button.
-

Verify "MEDIUM" Manifold Pressure Setting on Original Control Board

1. The setting value will display on the remote control.
2. Locate DIP1 on the control board. Move DIP switch #1 to the ON position (UP).
3. Push MAX button then MIN button within 2 seconds and hold down for more than 5 seconds. Remote will display a "P". Release both buttons.
4. Push and hold the ADJ button. Setting number will display on the remote (NOTE: you will have 20 seconds to read this value).
5. Record the number displayed on Remote: _____
6. Release the ADJ button.

Section 12: Control Board Replacement Procedure Adjusting Manifold Pressure on NEW Control Board

NOTE: This adjustment to be performed on NEW control board.

Adjustment of “MINIMUM” Manifold Pressure Setting on NEW Control Board

1. The setting value will display on the remote control
2. Push and hold down the ADJ button.
3. While holding the ADJ button, push (tap) the MIN button. IF recorded value DOES NOT agree with current value, proceed to next step. IF value DOES agree, release the ADJ button and proceed to “**ADJUSTMENT OF “MAXIMUM” MANIFOLD PRESSURE SETTING ON NEW CONTROL BOARD**” step.
4. IF adjustment is needed, push and hold the ADJ button.
5. While holding the ADJ button, push the MIN button.
6. The current number [01 – 39] will display on Remote.
7. Continue to push the **MIN** button until you get the same value recorded during the “**VERIFY ‘MINIMUM’ MANIFOLD PRESSURE SETTING**” step.
8. **WARNING:** Every time you push the **MIN** button, the display will cycle up to the number 39. Once at 39, it will automatically reverse and cycle back down to 01.
9. Release the **ADJ** button.
10. Continue to “**ADJUSTMENT OF ‘MAXIMUM’ MANIFOLD PRESSURE SETTING**” step.

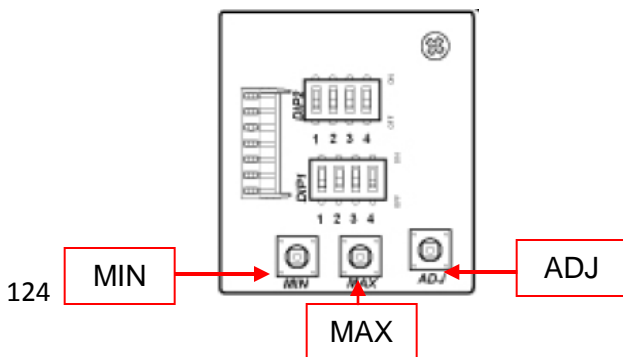

Section 12: Control Board Replacement Procedure Adjusting Manifold Pressure on NEW Control Board

NOTE: This adjustment to be performed on NEW control board.

Adjustment of “MAXIMUM” Manifold Pressure Setting on NEW Control Board

1. The setting value will display on the remote control.
2. Push and hold down **ADJ** button.
3. While holding **ADJ** button, push (tap) the **MAX** button. If recorded value **DOES NOT** agree with current value, proceed to next step. If value **DOES** agree, release the **ADJ** button and proceed to “**ADJUSTMENT OF ‘MEDIUM’ MANIFOLD PRESSURE SETTING**” step.
4. If adjustment is needed, push and hold down **ADJ** button.
5. While holding the **ADJ** button, push the **MAX** button.
6. The current number [01 – 39] will display on the remote control.
7. Continue to push the **MAX** button until you get the same value recorded during the “**VERIFY ‘MAXIMUM’ MANIFOLD PRESSURE SETTING**” step.
8. **WARNING:** Every time you press the **MAX** button, the display will cycle up to the number 39. Once at 39, it will automatically reverse and cycle back down to 01.
9. Release the **ADJ** button.
10. Continue to “**ADJUSTMENT OF ‘MEDIUM’ MANIFOLD PRESSURE SETTING (SLOW IGNITION POINT)**” step.

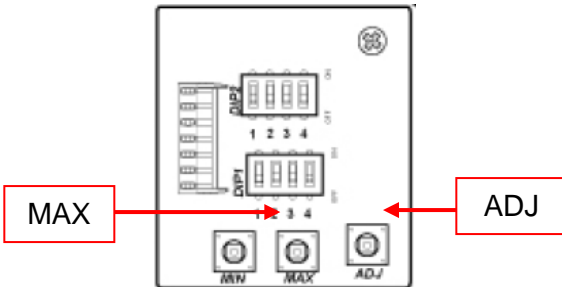

Section 12: Control Board Replacement Procedure Adjusting Manifold Pressure on NEW Control Board

NOTE: This adjustment to be performed on NEW control board.

Adjustment of “MEDIUM” Manifold Pressure Setting on NEW Control Board

1. The setting value will display on the remote control.
2. Locate **DIP1** on control board. Move **DIP switch #1** to **ON** position.
3. Push **MAX** button then **MIN** button within **2 seconds** and hold down for more than **5 seconds**. Remote control will display a “P.” Release both buttons.
4. Push and hold **ADJ** button. Setting number will display on remote control (**NOTE:** You have **20 seconds** to read this value).
5. While holding **ADJ** button, push **MIN** button to make the setting go **DOWN** or press the **MAX** button to make the setting to **UP**.
6. Continue until number displayed matches value recorded during the “**VERIFY ‘MEDIUM’ MANIFOLD PRESSURE SETTING**” step.
7. Follow remaining procedures to return tankless water heater to normal operation.

