



Russell[™]
By Rheem

SUBMITTAL COVER SHEET

PROJECT NAME _____
LOCATION _____
ARCHITECT _____
ENGINEER _____
CONTRACTOR _____
SUBMITTED BY _____ DATE _____

UNIT SUMMARY

Quantity						
Unit Designation						
Model No.						
Total Cooling						
Sensible Cooling						
Air Ent. Evaporator						
Air Lvg. Evaporator						
Heating Input						
Heating Output						
CFM/ESP						
EER/SEER						
Electrical						
Minimum Ampacity						
Min.-Max. Breaker						
Net Unit Weight						
Accessory						
Catalog Form Number						

ACCESSORIES:

NOTES:

DOWNFLOW GAS FURNACE

S802V

Input Rates 75 to 125 kBTU [22 to 37 kW]

JOB NAME _____ MODEL NO. _____

CONTRACTOR _____ OUTDOOR UNIT MODEL NO. _____

ENGINEER _____ LOCATION _____

SUBMITTED FOR APPROVAL RECORD ORDER NO. _____

DATE _____

UNIT DATA

HEATING PERFORMANCE

TOTAL CAPACITY INPUT* MBH [kW]

TOTAL CAPACITY OUTPUT* MBH [kW]

DESIGN TEMP. RISE °F [°C] DB

AFUE %

CALIFORNIA SEASONAL EFFICIENCY %
(*uses blower motor heat)

SUPPLY AIR BLOWER PERFORMANCE

TOTAL AIR SUPPLY CFM [L/s]

TOTAL RESISTANCE EXTERNAL TO UNIT IWG

BLOWER SPEED RPM

POWER OUTPUT REQUIREMENT BHP

MOTOR RATING HP [W]

POWER INPUT REQUIREMENT kW

ELECTRICAL DATA

POWER SUPPLY Hz

TOTAL UNIT AMPACITY AMPS

MINIMUM WIRE SIZE AWG

MAXIMUM OVERCURRENT DEVICE FUSES/HACR BREAKER AMPS

FEATURES FOR S802V DOWNFLOW

- 80% residential Gas Furnace CSA certified
- Two stages of operation to save energy and maintain optimal comfort level.
- Variable speed blower motor technology provides ultimate humidity control, quieter sound levels, and year round energy savings
- EcoNet enabled HVAC product
- 7 Segment LED all units
- Direct Spark Ignition for reliability and longevity
- Heat exchanger is removable for improved serviceability. Aluminized steel construction provides maximum corrosion resistance and thermal fatigue reliability.
- Low profile 34" cabinet ideal for space constrained installations
- Integrated Control board features dip switches for easy system set up
- Insulated blower compartment
- QR code for quick access to product information from your smart phone or tablet
- Compatible with single or two stage thermostats. For optimal performance a two stage thermostat is recommended.

FIELD INSTALLED ACCESSORIES

- Filter Rack RXGF-CC
- Combustible Floor Base RXGC-B17
- Combustible Floor Base RXGC-B21
- Combustible Floor Base RXGC-B24
- EcoNet Control RETST600SYS



9001:2015



Downflow Dimensions

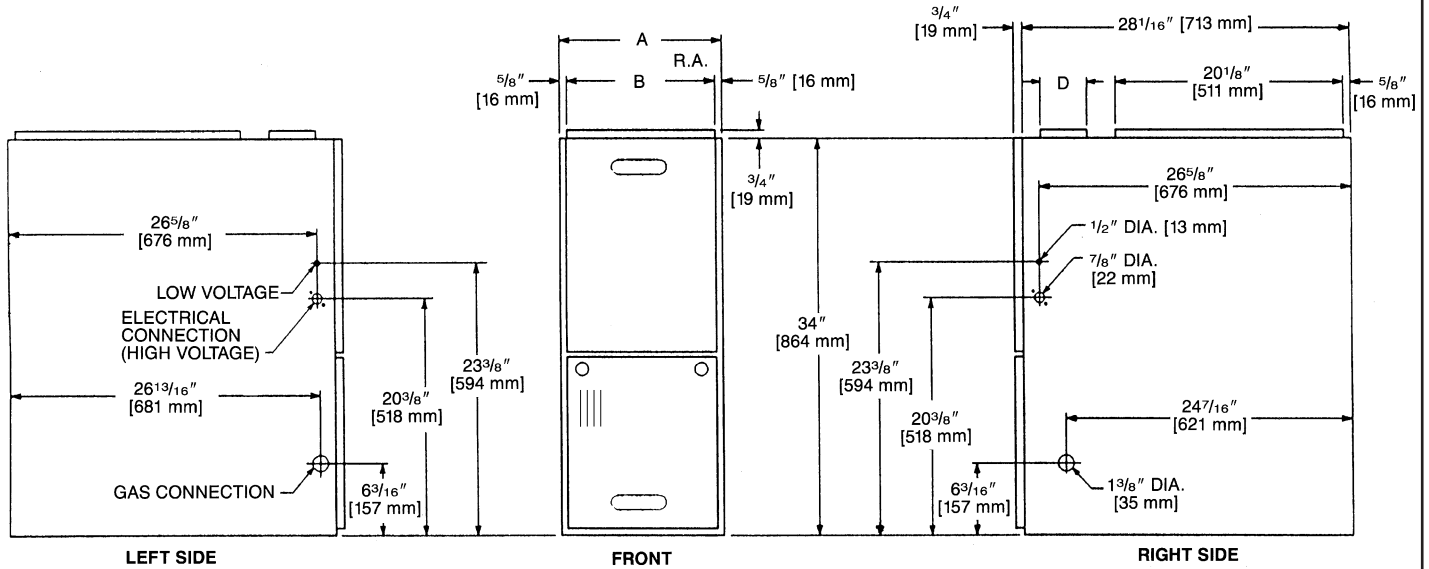
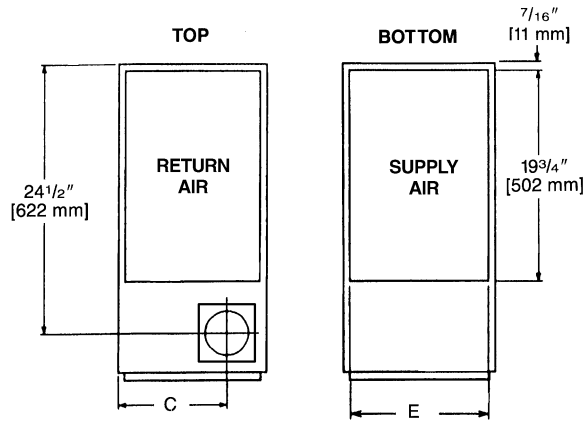

Dimensions and Clearance to Combustible Material (inches) [mm]

MODEL S802V-SERIES	A	B	C	D	E	REDUCED CLEARANCES (IN.) [mm]						SHIP. WGTS. (LBS.) [kg]
						LEFT SIDE	RIGHT SIDE	BACK	TOP	FRONT	VENT	
075317	17 1/2 [445]	16 11/32 [415]	12 1/8 [308]	①	16 5/8 [422]	0	3 ②	0	1 [25]	3 [76]	6 [152] ③	110 [49.9]
075421	21 [533]	19 27/32 [504]	13 7/8 [352]	①	20 1/8 [511]	0	0	0	1 [25]	3 [76]	6 [152] ③	115 [52.2]
100	21 [533]	19 27/32 [504]	13 7/8 [352]	①	20 1/8 [511]	0	0	0	1 [25]	3 [76]	6 [152] ③	120 [54.4]
125	24 1/2 [622]	23 11/32 [593]	15 5/8 [397]	①	23 5/8 [600]	0	0	0	1 [25]	3 [76]	6 [152] ③	140 [63.5]

NOTES: ① May require a 3" [76 mm] to 4" [102 mm] or 3" [76 mm] to 5" [127 mm] adapter.

② May be 0" [0 mm] with type B vent.

③ May be 1" [25 mm] with type B vent.

Furnaces must be vented in accordance with the National Fuel Gas Code, ANSI Z223.1 and/or Can/CGA-B149 Installation Codes and in accordance with local codes.

[] Designates Metric Conversions



Russell™ By Rheem

5600 Old Greenwood Road, Fort Smith, AR 72908

Before proceeding with installation, refer to installation instructions packaged with each model, as well as complying with all Federal, State, Provincial, and Local codes, regulations, and practices.