



## Ruud Ultra™ Series Communicating Two-Stage Variable Speed Upflow/Horizontal Gas Furnace



### U802V- Upflow/Horizontal Series

80% A.F.U.E.†

Input Rates 50-125 kBtu



†A.F.U.E. (Annual Fuel Utilization Efficiency) calculated in accordance with Department of Energy test procedures.

- 80% residential Gas Furnace CSA certified
- Two stages of operation to save energy and maintain optimal comfort level.
- Variable speed blower motor technology provides ultimate humidity control quieter sound levels and year round energy savings
- The Ultra™ Series U802V is part of a new line of Ruud smart heating, cooling and water heating products. Using the latest in sensor technology and a powerful EcoNet® monitoring system, Ruud provides homeowners with a new level of protection, control and energy savings. Ruud smart heating, cooling and water heating products will alert the homeowner if there is ever an issue via the EcoNet Smart Thermostat and the EcoNet Mobile app\*. The EcoNet Mobile App makes it easy for homeowners to manage their home comfort environment at home or on-the-go\*, while enjoying the convenience and savings benefits of a highly efficient system.
- 3 way multi poise design UF / HZ
- PlusOne™ Diagnostics — 7 Segment LED all units
- PlusOne™ Ignition System – DSI for reliability and longevity
- Heat exchanger is removable for improved serviceability. Aluminized steel construction provides maximum corrosion resistance and thermal fatigue reliability.
- Solid doors provide quiet operation
- Solid bottom
- Insulated blower compartment
- Low profile 34" cabinet ideal for space constrained installations
- Blower shelf design – serviceable in all furnace orientations
- Hemmed edges on cabinets and doors
- 1/4 turn door knobs for tool less access
- Integrated Control board features dip switches for easy system set up
- QR code for quick access to product information from your smart phone or tablet
- Compatible with single or two stage thermostats. For optimal performance a two stage thermostat is recommended.
- Cabinet air leakage less than 2% at 1 inch H<sub>2</sub>O when tested in accordance with ASHRAE standard 193

\*WiFi broadband internet connection required. Download the EcoNet App from the App Store or Google Play to set up your EcoNet Smart Thermostat. Receipt of notifications depend on home WiFi set up. WiFi broadband internet connection required.

# TABLE OF CONTENTS

Standard & Optional Equipment .....	3
Model Features/Physical Data & Specifications .....	4
Model Number Identification .....	5
Dimensional Data .....	6-7
Blower Performance Data .....	8
Accessories .....	9-10
Limited Warranty .....	11

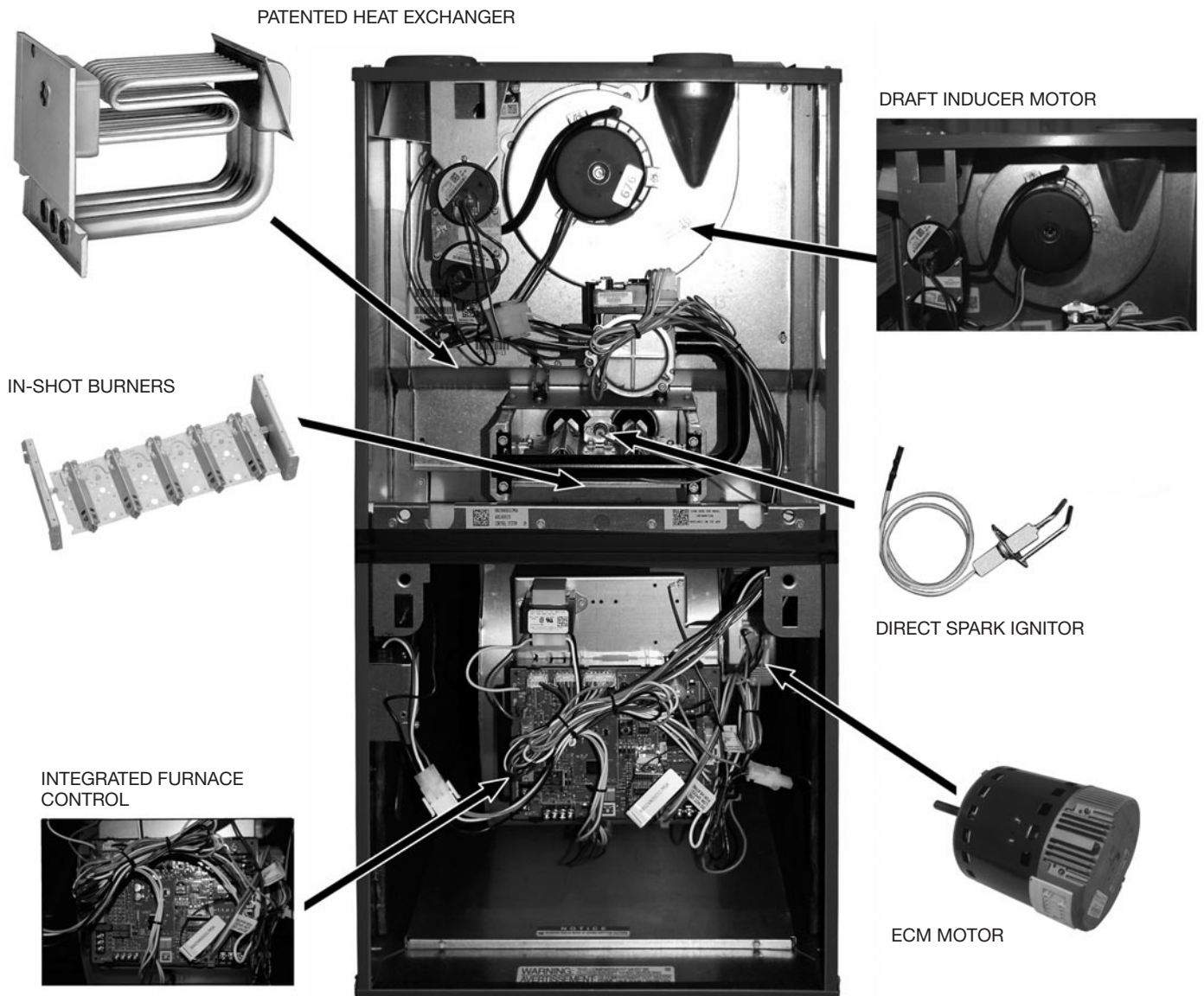

## STANDARD EQUIPMENT

Completely assembled and wired; 2 speed induced draft blower; high and low pressure switches; 2 stage redundant main gas control; blower compartment door safety switch; solid state time on/time off blower control; limit control; transformer; ECM blower motor. Furnaces are equipped with cooling/heating relay and transformer (50VA) ready for air conditioning applications. (Please note: a thermostat is not included as standard equipment.) Flame sensor diagnostics; fused-protection (secondary), **3rd speed option for continuous fan.**

## OPTIONAL EQUIPMENT

Side and bottom filter frame assembly. 4" Flue Adapter

NOTE: Furnace is not listed for use with fuels other than natural or L.P. (propane) gas.

The complete terms of limited and other warranties are available at our sales office, or through local installer.

All models can be converted by a qualified Ruud distributor or local service dealer to use L.P. (propane) gas without changing burners. Factory approved kits must be used to convert from natural to L.P. (propane) gas and may be ordered as optional accessories from a Ruud parts distributor.

For L.P. (propane) operation, refer to Conversion Kit Index Form.

NOTE: For natural and L.P. (propane) gas models, direct spark ignition is 100% safety lockout type.

**WARNING**  
THIS FURNACE IS NOT APPROVED  
OR RECOMMENDED  
FOR USE IN MOBILE HOMES

## Model Features

- 80% residential Gas Furnace CSA certified
- Two stages of operation to save energy and maintain optimal comfort level.
- Variable speed blower motor technology provides ultimate humidity control quieter sound levels and year round energy savings
- The Ultra™ Series U802V is part of a new line of Ruud smart heating, cooling and water heating products. Using the latest in sensor technology and a powerful EcoNet® monitoring system, Ruud provides homeowners with a new level of protection, control and energy savings. Ruud smart heating, cooling and water heating products will alert the homeowner if there is ever an issue via the EcoNet Smart Thermostat<sup>1</sup> and the EcoNet Mobile app. The EcoNet Mobile App makes it easy for homeowners to manage their home comfort environment at home or on-the-go\*, while enjoying the convenience and savings benefits of a highly efficient system.
- 3 way multi poise design UF / HZ
- PlusOne™ Diagnostics — 7 Segment LED all units
- PlusOne™ Ignition System – DSI for reliability and longevity
- Heat exchanger is removable for improved serviceability. Aluminized steel construction provides maximum corrosion resistance and thermal fatigue reliability.
- Solid doors provide quiet operation
- Solid bottom
- Insulated blower compartment
- Low profile 34" cabinet ideal for space constrained installations
- Blower shelf design serviceable in all furnace orientations
- Hemmed edges on cabinets and doors
- 1/4 turn door knobs for tool less access
- Integrated Controls board features dip switches for easy system set up
- QR code for quick access to product information from your smart phone or tablet
- Compatible with single or two stage thermostats. For optimal performance a two stage thermostat is recommended.

\*WiFi broadband internet connection required. Download the EcoNet App from the App Store or Google Play to set up your EcoNet Smart Thermostat. Receipt of notifications depend on home WiFi set up. WiFi broadband internet connection required.

## Physical Data and Specifications

MODEL NUMBERS U802V SERIES	U802VA050317M*A	U802VA075317M*A	U802VA075421M*A	U802VA100521M*A	U802VA125524M*A
High Input-BTU/Hr [kW] ②	50,000 [15]	75,000 [22]	75,000 [22]	100,000 [29]	125,000 [37]
Heating Capacity BTU/Hr [kW] ①	40,000 [12]	60,000 [18]	60,000 [18]	80,000 [23]	100,000 [29]
Low Input BTU/Hr [kW] ②	35,000 [10]	52,500 [15]	52,500 [15]	70,000 [20]	87,500 [25]
Low Heating Capacity BTU/Hr [kW] ①	28,000 [8]	42,000 [12]	42,000 [12]	56,000 [16]	70,000 [20]
Heat Ext. Static Pressure [kPa]	.18 [.045]	.20 [.050]	.20 [.050]	.28 [.070]	.28 [.070]
Blower (D x W) [mm]	11 x 7 [279 x 178]	11 x 7 [279 x 178]	11 x 7 [279 x 178]	11 x 10 [279 x 254]	11 x 10 [279 x 254]
Motor H.P. Type [W]	1/2 ECM [373]	1/2 ECM [373]	3/4 ECM [560]	3/4 ECM [560]	3/4 ECM [560]
Min. Circuit Ampacity	10	9	13	12	12
Min. Overload Protection Device	15	15	15	15	15
Max. Overload Protection Device	15	15	20	20	15
Max. and Factory Heating CFM [L/s]	890 [420]	1375 [649]	1580 [746]	1580 [746]	1985 [937]
Cooling CFM @ Rating Point [L/s]	1200 [566]	1200 [566]	1600 [755]	2000 [944]	2000 [944]
Max. E.S.P. (In. W.C.) [kPa]	1.0 [.249]	1.0 [.249]	1.0 [.249]	1.0 [.249]	1.0 [.249]
Temperature Rise Range °F [°C]—High Input	25-55 [13.9-30.6]	25-55 [13.9-30.6]	25-55 [13.9-30.6]	35-65 [19.4-36.1]	35-65 [19.4-36.1]
Temperature Rise Range °F [°C]—Low Input	20-50 [12.8-29.4]	20-50 [12.8-29.4]	20-50 [12.8-29.4]	30-60 [18.3-35]	30-60 [18.3-35]
Max. Outlet Air Temp. °F [°C]	155 [68.3]	155 [68.3]	165 [73.8]	180 [82.2]	180 [82.2]
Approx. Shipping Weight (Lbs.) [kg]	125 [57]	125 [57]	140 [64]	140 [64]	150 [68]
AFUE ①	80.0%	80.0%	80.0%	80.0%	80.0%

NOTES: All models are 115V, 60HZ, 1 Ph. Gas connection size for all models is 1/2" [12 mm] N.P.T.

① In accordance with D.O.E. test procedures.

② See Conversion Kit Index Form for high altitude derate.

\* S = Standard, X = Low NOx

This furnace does not meet air district requirements of 14 ng/J NOx emissions limit, and thus is subject to a mitigation fee of up to \$450. This furnace is not eligible for the Clean Air Furnace Rebate Program: [www.CleanAirFurnaceRebate.com](http://www.CleanAirFurnaceRebate.com).

This furnace is to be installed for propane firing only in air districts requiring 14 ng/J NOx emission limits. Operating in natural gas mode is in violation of these Rules.

[ ] Designates Metric Conversions

## Model Number Identification

<u>U</u>	<u>80</u>	<u>2</u>	<u>V</u>	<u>A</u>	<u>075</u>	<u>4</u>	<u>17</u>	<u>M</u>	<u>S</u>	<u>A</u>
Ruud	80 = 80% AFUE	2 = Two Stage	V = Variable Speed ECM	Design Series A = 1st Design	Input BTU/HR [kW]	3 = Up to 3 Ton 4 = 2½ to 4 Ton 5 = 3½ to 5 Ton	Cabinet Width 17 = 17.5" 21 = 21" 24 = 24.5"	M = Multi	X = Low NO <sub>x</sub> S = Standard	Revision- Marketing (A – First Time Release)
					050 = 50,000 [15] 075 = 75,000 [22] 100 = 100,000 [29] 125 = 125,000 [37]					

[ ] Designates Metric Conversions

## Upflow Application

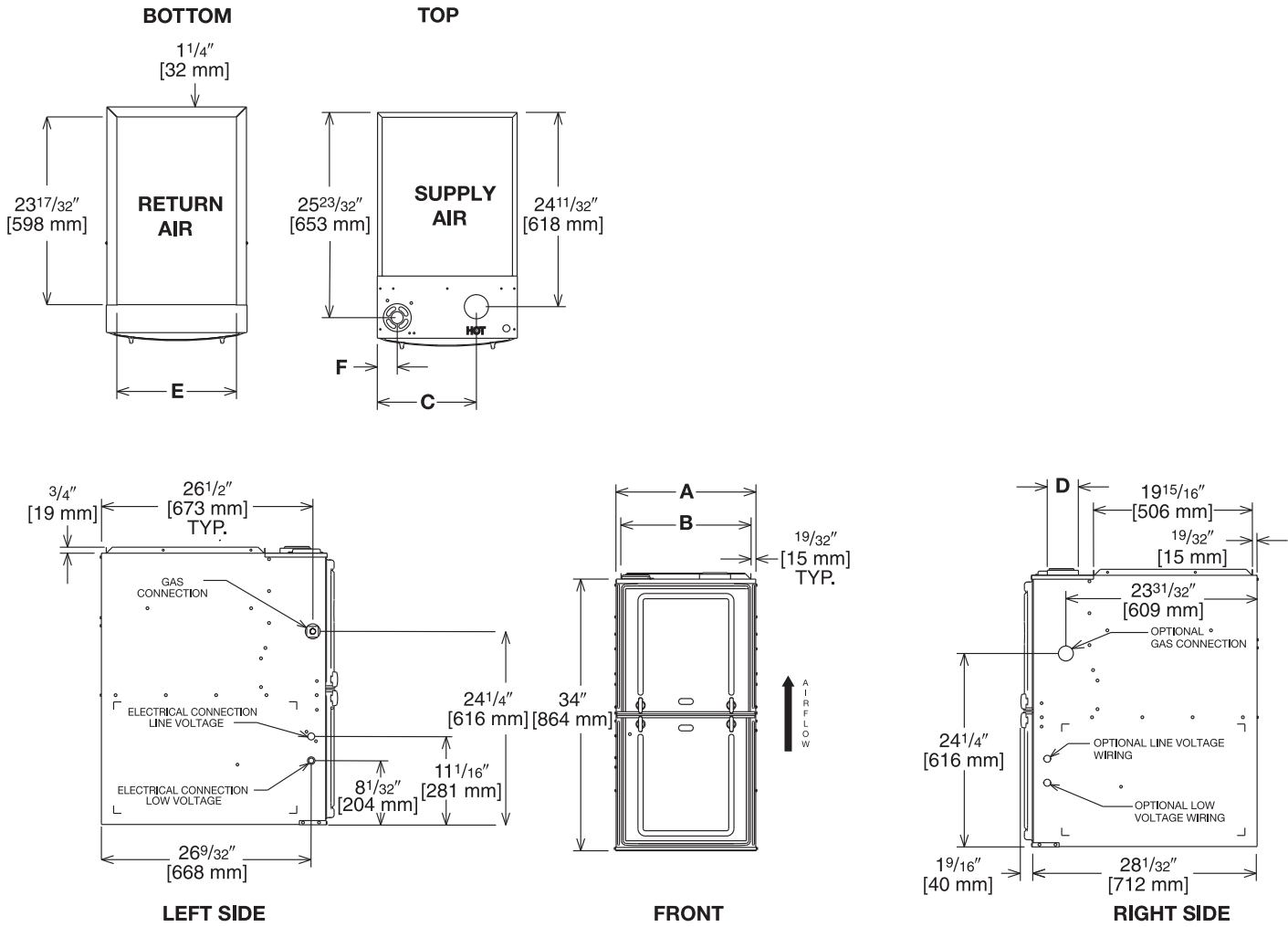

Illustration  
ST-A1220-04-00  
FIGURE 1

## Dimensional Data: Upflow Model

MODEL U802V-	A	B	C	D	E	F	MINIMUM CLEARANCE (IN.) [mm]						SHIP WGTS. (LBS.) [kg]
							LEFT SIDE	RIGHT SIDE	BACK	TOP	FRONT	VENT	
050, 075317	17 1/2 [445]	16 11/32 [415]	12 3/8 [314]	①	15 [381]	2 1/2 [64]	0	3 [76] ②	0	1 [25]	3 [76]	6 [152] ③	125 [57]
075421, 100	21 [533]	19 27/32 [504]	14 1/8 [359]	①	18 1/2 [470]	2 1/2 [64]	0	0	0	1 [25]	3 [76]	6 [152] ③	140 [64]
125	24 1/2 [622]	23 11/32 [593]	15 7/8 [403]	①	22 [559]	2 1/2 [64]	0	0	0	1 [25]	3 [76]	6 [152] ③	150 [68]

NOTES: ① May require a 3" [76 mm] to 4" [102 mm] or 3" [76 mm] to 5" [127 mm] adapter.

② May be 0" [0 mm] with type B vent.

③ May be 1" [25 mm] with type B vent.

Furnaces must be vented in accordance with the National Fuel Gas Code, ANSI Z223.1 in accordance with local codes.

[ ] Designates Metric Conversions

## Horizontal Application

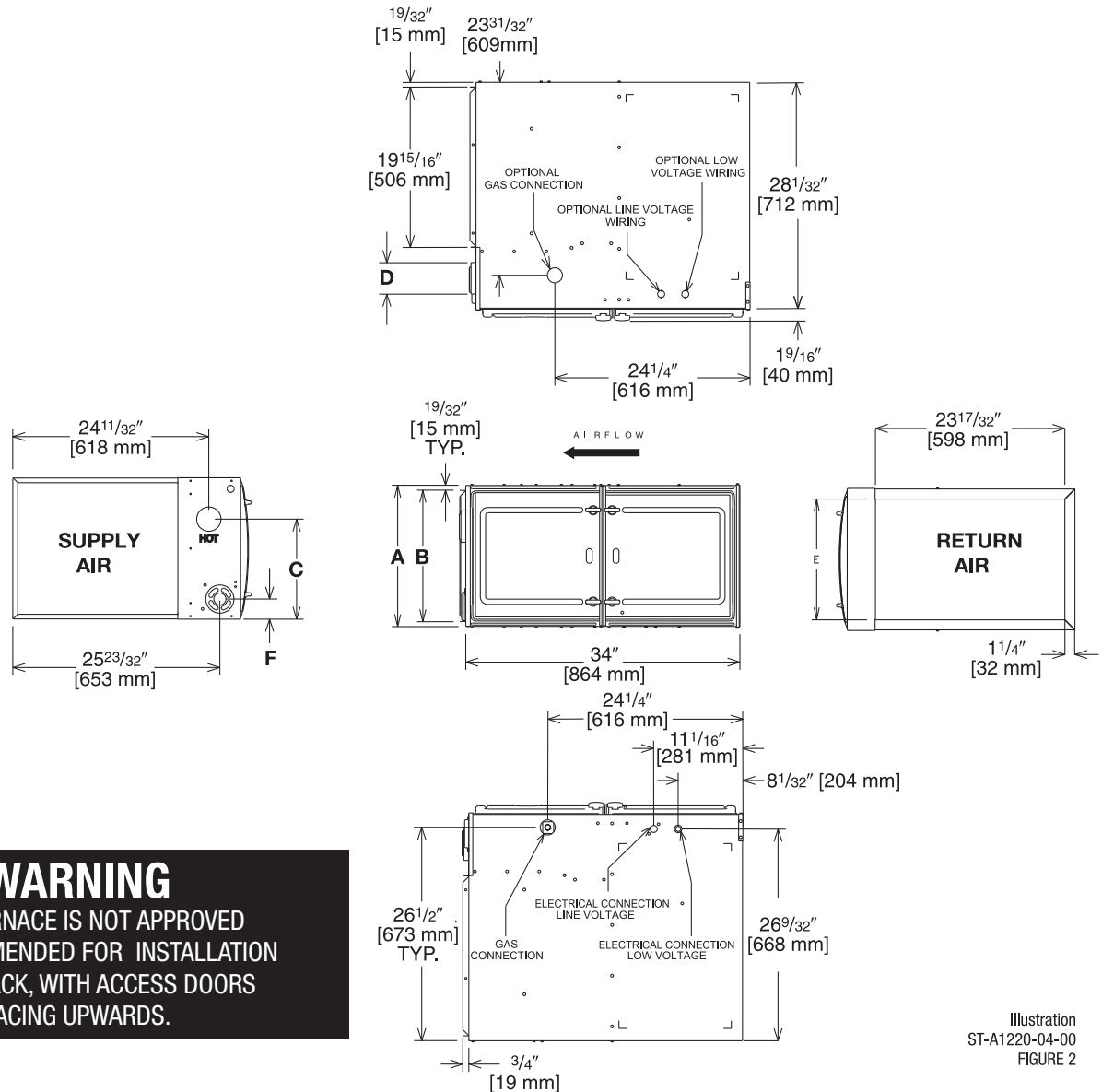

Illustration  
ST-A1220-04-00  
FIGURE 2

**WARNING**  
THIS FURNACE IS NOT APPROVED  
OR RECOMMENDED FOR INSTALLATION  
ON ITS BACK, WITH ACCESS DOORS  
FACING UPWARDS.

## Dimensional Data: Horizontal Model

MODEL U802V-	A	B	C	D	E	F	MINIMUM CLEARANCE (IN.) [mm]						SHIP WGTS. (LBS.) [kg]
							SUPPLY AIR SIDE	RETURN AIR SIDE	BACK	TOP	FRONT	VENT	
050, 075317	17 1/2 [445]	16 11/32 [415]	12 3/8 [314]	①	15 [381]	2 1/2 [64]	3 [76] ②	0	0	1 [25]	3 [76]	6 [152] ③	125 [57]
075421, 100	21 [533]	19 27/32 [504]	14 1/8 [359]	①	18 1/2 [470]	2 1/2 [64]	0	0	0	1 [25]	3 [76]	6 [152] ③	140 [64]
125	24 1/2 [622]	23 11/32 [593]	15 7/8 [403]	①	22 [559]	2 1/2 [64]	0	0	0	1 [25]	3 [76]	6 [152] ③	150 [68]

NOTES: ① May require a 3" [76 mm] to 4" [102 mm] or 3" [76 mm] to 5" [127 mm] adapter.

② May be 0" [0 mm] with type B vent.

③ May be 1" [25 mm] with type B vent.

Furnaces must be vented in accordance with the National Fuel Gas Code, ANSI Z223.1 in accordance with local codes.

[ ] Designates Metric Conversions

## Blower Performance Data

MODEL NUMBER				U802VA050317MSA	U802VA075317MSA	U802VA075421MSA	U802VA100521MSA	U802VA125524MSA	
TARGET GAS HEATING AIRFLOW	HIGH HEATING CFM	SW15 = OFF	SW16 = OFF	890	1375	1340	1580	1985	
		SW15 = ON	SW16 = OFF	790	1145	1115	1380	1700	
		SW15 = OFF	SW16 = ON	DO NOT USE					
		SW15 = ON	SW16 = ON	735	1015	980	1260	1530	
	LOW HEATING CFM	SW13 = OFF	SW14 = OFF	835	1077	1030	1390	1500	
		SW13 = ON	SW14 = OFF	590	880	820	1180	1275	
		SW13 = OFF	SW14 = ON	DO NOT USE					
		SW13 = ON	SW14 = ON	510	810	720	1040	1150	
TARGET COOLING/HEAT-PUMP AIRFLOW	HIGH COOLING CFM	SW4 = OFF	SW5 = OFF	1200	1200	1600	2000	2000	
		SW4 = ON	SW5 = OFF	1000	1000	1400	1600	1600	
		SW4 = OFF	SW5 = ON	800	800	1200	1400	1400	
		SW4 = ON	SW5 = ON	600	600	1000	1200	1200	
	LOW COOLING CFM	SW4 = OFF	SW5 = OFF	900	900	1200	1500	1500	
		SW4 = ON	SW5 = OFF	750	750	1050	1200	1200	
		SW4 = OFF	SW5 = ON	600	600	900	1050	1050	
		SW4 = ON	SW5 = ON	450	450	750	900	900	

Table represents blower performance data without filters.

[ ] Designates Metric Conversions



**SIDE RETURN FILTER RACK: RXGF-CD**  
**BOTTOM RETURN FILTER RACK FOR**  
**UPFLOW APPLICATION: RXGF-CB**

FILTER RACK FILTER SIZES* INCHES [mm]		
MODEL U802V	RXGF-CB (UPFLOW/HORIZONTAL)	RXGF-CD (UPFLOW) SIDE RETURN
050 & 075317	15 <sup>3</sup> / <sub>4</sub> x 25 [400 x 635]	15 <sup>3</sup> / <sub>4</sub> x 25 [400 x 635]
075421 & 100	19 <sup>1</sup> / <sub>4</sub> x 25 [489 x 635]	15 <sup>3</sup> / <sub>4</sub> x 25 [400 x 635]
125	22 <sup>3</sup> / <sub>4</sub> x 25 [578 x 635]	15 <sup>3</sup> / <sub>4</sub> x 25 [400 x 635]

**INDOOR COIL CASINGS**

MODEL NUMBER
RXBC-D17AI
RXBC-D21AI
RXBC-D21BI
RXBC-D24AI

**4" FLUE ADAPTER: RXGW-C01**

**WARNING: IMPORTANT NOTICE**

A SOLID METAL BASE PLATE (SEE TABLE) MUST BE IN PLACE WHEN THE FURNACE IS INSTALLED WITH SIDE AIR RETURN DUCTS. FAILURE TO INSTALL A BASE PLATE COULD CAUSE PRODUCTS OF COMBUSTION TO BE CIRCULATED INTO THE LIVING SPACE AND CREATE POTENTIALLY HAZARDOUS CONDITIONS.

FURNACE WIDTH IN. [mm]	SOLID BOTTOM KIT NO.	BASE PLATE NO.	BASE PLATE SIZE IN. [mm]
17 <sup>1</sup> / <sub>2</sub> [445]	RXGB-D17	AE-61874-02	15 <sup>1</sup> / <sub>8</sub> x 23 <sup>9</sup> / <sub>16</sub> [384 x 598]
21 [533]	RXGB-D21	AE-61874-03	18 <sup>5</sup> / <sub>8</sub> x 23 <sup>9</sup> / <sub>16</sub> [473 x 598]
24 <sup>1</sup> / <sub>2</sub> [622]	RXGB-D24	AE-61874-04	25 <sup>5</sup> / <sub>8</sub> x 23 <sup>9</sup> / <sub>16</sub> [651 x 598]

**FOR HIGH ALTITUDES:**

**OPTION CODE FOR HIGH ALTITUDE: U.S.**

None required for high altitudes.

**HIGH ALTITUDE CONVERSION KITS: U.S.**

None required for high altitudes.

**80+ HIGH ALTITUDE INSTRUCTIONS**

**CAUTION:** Always follow National Fuel Gas Code (NFGC) guidelines when converting for high altitudes.

High altitude option codes are not required for these models. However, the burner orifice size needs to be recalculated and verified at elevations above 2000 ft. See Installation Instructions for more information.

[ ] Designates Metric Conversions



## THE ECONET® SMART THERMOSTAT

**BUILT-IN WIFI**

**4.3" LCD TOUCH SCREEN**

**LOCAL WEATHER** – Current conditions plus 6-day forecast

**5 OPERATING MODES** – Heat, Cool, Auto, Emergency Heat and Fan Only

**7-DAY PROGRAMMABLE SCHEDULE** – Offers comfort without thought

**ONE-TOUCH AWAY** – Quickly switch to your energy-saving away preferences

**VACATION SCHEDULING** – Allows you to save while you're away and come home to comfort

**MOTION SENSOR** – Automatically wakes the screen as you approach

**STANDBY SCREEN** – Displays indoor temperature and current weather



**UETST700SYS**

## OPERATIONAL FEATURES

**AUTOMATIC CHANGEOVER** – Transitions between heating and cooling automatically to keep the house comfortable

**INTEGRATED WATER CONTROL** – Enables easy water heater management

**SMOOTH ARRIVAL** – Prompts the system to start ahead of schedule to ensure the home is at the desired temperature at the scheduled time

**HUMIDITY CONTROL** – Supports humidifier accessories or over-cool based dehumidification

**DETAILED OPERATING STATUS** – View pertinent equipment status information and run times

**CONTINUOUS FAN** – Offers 5 speeds (Low, Medium Low, Medium, Medium High, High)

**SHORT-CYCLE PROTECTION** – Avoids damage to equipment from short run cycles

## MONITORING & REMOTE CONTROL FEATURES

**ACTIVE MONITORING** – Alerts to problems that need immediate attention

**REMOTE CONTROL** – Allows adjusting of comfort and settings from anywhere using a mobile device

**SERVICE ALERTS** – Sends routine maintenance reminders

**AIR FILTER MONITORING** – Detects when it's time to replace the air filter

**ALARM HISTORY** – Displays time-stamped alarm codes with clear descriptions

## ECONET SMART THERMOSTAT COMPATIBILITY

Models	Heating & Cooling									
	Gas Furnaces				Air Handlers		Air Conditioners		Heat Pumps	
	U802V	U96V	U97V	U98V	RHMV	RH2T	UA20	UA17*	UP20	UP17
UETST700SYS	✓	✓	✓	✓	✓	✓	✓	✓	✓	✓

\*Models not EcoNet Enabled: RA1724AJ2NB, RA1736AJ2NB, RA1748AJ2NB, RA1760AJ2NB

**GENERAL TERMS OF LIMITED WARRANTY\***

Ruud will furnish a replacement for any part of this product which fails in normal use and service within the applicable period stated, in accordance with the terms of the limited warranty.

**\*For complete details of the Limited and Conditional Warranties, including applicable terms and conditions, contact your local contractor or the Manufacturer for a copy of the product warranty certificate.**

Parts\* .....Ten (10) Years  
Heat Exchanger .....Limited Lifetime



*In keeping with its policy of continuous progress and product improvement, Ruud reserves the right to make changes without notice.*

Ruud Heating, Cooling & Water Heating • 5600 Old Greenwood Road  
Fort Smith, Arkansas 72908 • [www.ruud.com](http://www.ruud.com)

Ruud Canada • 125 Edgeware Road, Unit 1  
Brampton, Ontario • L6Y 0P5

**RELY ON RUUD.™**

PRINTED IN U.S.A. 4/20 QG FORM NO. G22-546 REV. 7