



The new degree of comfort.®

Endeavor® Line *Classic*® Series Gas Furnaces



R801V

80% A.F.U.E.†

EcoNet® Enabled

Heating Stages: Single Stage

Motor Type: Constant CFM

Input Rates: 50-150 kBTU [14.65-44.0 kW]

Configuration Options: Upflow/Horizontal



† A.F.U.E. (Annual Fuel Utilization Efficiency) calculated in accordance with Department of Energy test procedures.

The Bluetooth® word mark and logos are registered trademarks owned by Bluetooth SIG, Inc. and any use of such marks by Rheem® is under license. Other trademarks and trade names are those of their respective owners.

Table of Contents

Features & Benefits	3
Model Number Identification	4
Physical Data and Specifications	5
Dimensional Data	6-7
Blower Performance Data	8
Accessories	9-10
Limited Warranty	12

Features and Benefits

- **PlusOne® Diagnostics:** With the Rheem Contractor & EcoNet® Apps, built-in EcoNet® & Bluetooth® technology makes monitoring, troubleshooting and repairing the product easier than ever before
- **Dip Switch Free Installation Commissioning via Bluetooth® Technology:** Seamless final install step without DIP switch configuration using the Rheem Contractor App
- **PlusOne® Ignition System:** Proven Direct Spark Ignition (DSI) for reliability and longevity
- **Constant CFM Motor:** Truly variable speed technology allows for ultimate humidity control, quieter sound levels and year-round energy savings
- **Quieter Operation¹:** A fully insulated blower cabinet, solid bottom and truly variable speed airflow technology makes this furnace one of the quieter options available
- **EcoNet® Enabled Furnace:** The latest in sensor technology and the EcoNet® monitoring system provides a new level of protection, control and energy savings
- **Allows on-the-go control** and receipt of system alerts by the homeowner via the EcoNet® Smart Thermostat and EcoNet® App²

¹Based on manufacturer's furnace offering, and the product's heating stages, motor type and cabinet insulation. Sound levels are also dependent on furnace location and installation.

²Wifi broadband internet connection required. Download the EcoNet® App from the App Store® or Google Play® to set up your EcoNet® Smart Thermostat. Receipt of notifications depend on home WiFi set up. Amazon, Alexa and all related logos are trademarks of Amazon.com, Inc. or its affiliates.

Gas Furnaces

<u>R</u>	<u>80</u>	<u>1</u>	<u>V</u>	<u>50</u>	<u>3</u>	<u>A</u>	<u>14</u>	<u>UH</u>	<u>S</u>	<u>C</u>	<u>A</u>	<u>P</u>
Brand	Furnace Efficiency	Stages of Heating	Motor Type	Heating Input (BTUH)	AC Max. Capacity	Major Series	Width	Position	NOx	Controls	Minor Series	Option Code
R - Rheem	80- 80% AFUE	1 - Single-Stage	V - ECM Variable Speed	050 - 50,000 [14.7 kW] 075 - 75,000 [22.0 kW] 100 - 100,000 [29.3 kW] 125 - 125,000 [36.6 kW] 150 - 150,000 [44.0 kW]	3 - 3 ton drive 4 - 4 ton drive 5 - 5 ton drive	A - 1st Design Series	14 - 14" Width 17 - 17.5" Width 21 - 21" Width 24 - 24.5" Width	UH - Upflow Horizontal	S - Standard N - Low NOx	C - Communicating, EcoNet®, Bluetooth®	A - 1st Series	P - Premium Grade

[] Designates Metric Conversions

AVAILABLE MODELS
R801V0503A14UH*CAP
R801V0504A17UH*CAP
R801V0754A17UH*CAP
R801V0755A21UH*CAP
R801V1004A17UH*CAP
R801V1005A21UH*CAP
R801V1255A24UH*CAP
R801V1505A24UH*CAP

* S = Standard, N = Low NOx

STANDARD EQUIPMENT
100% Safety Lock Out
29-4C Stainless Steel Secondary Heat Exchanger Design
Adjustable Cool Fan Off Delay
Aluminized steel primary heat exchanger design
Blower Compartment Door Safety Switch
Bluetooth® setup and diagnostics
Completely assembled and wired
Direct Drive Motor
EcoNet® Thermostat Connections
Electronic On/Off Blower Time Control
Fully Insulated Heat Exchanger Cabinet
Humidifier Terminal Connection
Induced Draft Motor
Limit Controls
Low Speed Continuous Fan Option
Manual Shut-Off Valve
Marked condensate hoses
One Hour Automatic Retry
Power And Self-Test Diagnostics
Pressure Switch
Constant CFM Electrically Communicated Blower Motor
Redundant Main Gas Control
Single Stage Heating Thermostat Connection
Solid Bottom
Blower Insulation
Two Plus* Stage Cooling Thermostat Connection
Dehumidification using either Bluetooth® App or EcoNet® Thermostat

NOTE: A thermostat is not included as standard equipment
 *When Connected to Three Speed Or Modulating AC/HP Product

WARNING
 THIS FURNACE IS NOT APPROVED
 OR RECOMMENDED
 FOR USE IN MOBILE HOMES

Physical Data and Specifications—Upflow Models

MODEL NUMBERS R801V 1stg VS-CT UP/HZ SERIES	R801V0503 A14UH*CAP	R801V0504 A17UH*CAP	R801V0754 A17UH*CAP	R801V0755 A21UH*CAP	R801V1004 A17UH*CAP	R801V1005 A21UH*CAP	R801V1255 A24UH*CAP	R801V1505 A24UH*CAP
Input-BTU/Hr [kW]	50,000 [15]	50,000 [15]	75,000 [22]	75,000 [22]	100,000 [29]	100,000 [29]	125,000 [37]	150,000 [44]
Heating Capacity BTU/Hr [kW] ①	40,000 [12]	40,000 [12]	60,000 [18]	60,000 [18]	80,000 [23]	80,000 [23]	100,000 [29]	120,000 [35]
Blower (D x W) [mm]	11 x 6 [279 x 152]	11 x 7 [279 x 178]	11 x 7 [279 x 178]	11 x 7 [279 x 178]	11 x 7 [279 x 178]	11 x 10 [279 x 254]	11 x 10 [279 x 254]	11 x 10 [279 x 254]
Motor H.P. [W] Type	1/2 [373] VS-CT(ECM)	3/4 [560] VS-CT(ECM)	3/4 [560] VS-CT(ECM)	1 [746] VS-CT(ECM)	3/4 [560] VS-CT(ECM)	3/4 [560] VS-CT(ECM)	3/4 [560] VS-CT(ECM)	1 [746] VS-CT(ECM)
Min. Circuit Ampacity	9	13	9	15	12	12	12	15
Min. Overload Protection Device	15	15	15	20	15	15	15	20
Max. Overload Protection Device	15	20	15	25	20	15	15	25
Motor Full Load Amps	6.1	9.6	9.6	12.4	9.6	9.6	9.6	12.4
Heating CFM [L/s]	960 [453]	930 [439]	1450 [684]	1425 [673]	1285 [606]	1550 [732]	1900 [897]	1850 [873]
MAX Cooling CFM [L/s]	1240 [585]	1650 [779]	1650 [779]	1980 [934]	1650 [779]	1980 [934]	1980 [934]	1980 [934]
MIN Cooling CFM [L/s]	300 [142]	500 [236]	500 [236]	500 [236]	500 [236]	500 [236]	500 [236]	500 [236]
Fan CFM [L/s]	600 [283]	800 [378]	800 [378]	1000 [472]	800 [378]	1000 [472]	1000 [472]	1000 [472]
Max. E.S.P. (In. W.C.) [kPa]	1.0 [0.25]	1.0 [0.25]	1.0 [0.25]	1.0 [0.25]	1.0 [0.25]	1.0 [0.25]	1.0 [0.25]	1.0 [0.25]
Temperature Rise Range °F [°C]	25-55 [13.9-30.6]	25-55 [13.9-30.6]	25-55 [13.9-30.6]	25-55 [13.9-30.6]	40-70 [23-39]	35-65 [19.4-36.1]	40-70 [23-39]	45-75 [25-42]
Approx. Shipping Weight (Lbs.) [kg]	104.5 [47]	110 [50]	117.5 [53]	135 [61]	131.5 [60]	140 [64]	143.5 [65]	155.5 [71]
AFUE ②	80.0%	80.0%	80.0%	80.0%	80.0%	80.0%	80.0%	80.0%

NOTES: All models are 115V, 60HZ, 1 Ph. Gas connection size for all models is 1/2" [13 mm] N.P.T.

① In accordance with D.O.E. test procedures.

② See Conversion Kit Index Form for high altitude derate.

*S=Standard, N=Low NOx

This furnace does not meet air district requirements of 14 ng/J NOx emissions limit, and thus is subject to a mitigation fee of up to \$450. This furnace is not eligible for the Clean Air Furnace Rebate Program: www.CleanAirFurnaceRebate.com.

This furnace is to be installed for propane firing only in air districts requiring 14 ng/J NOx emission limits. Operating in natural gas mode is in violation of these Rules.

[] Designates Metric Conversions

Upflow Application

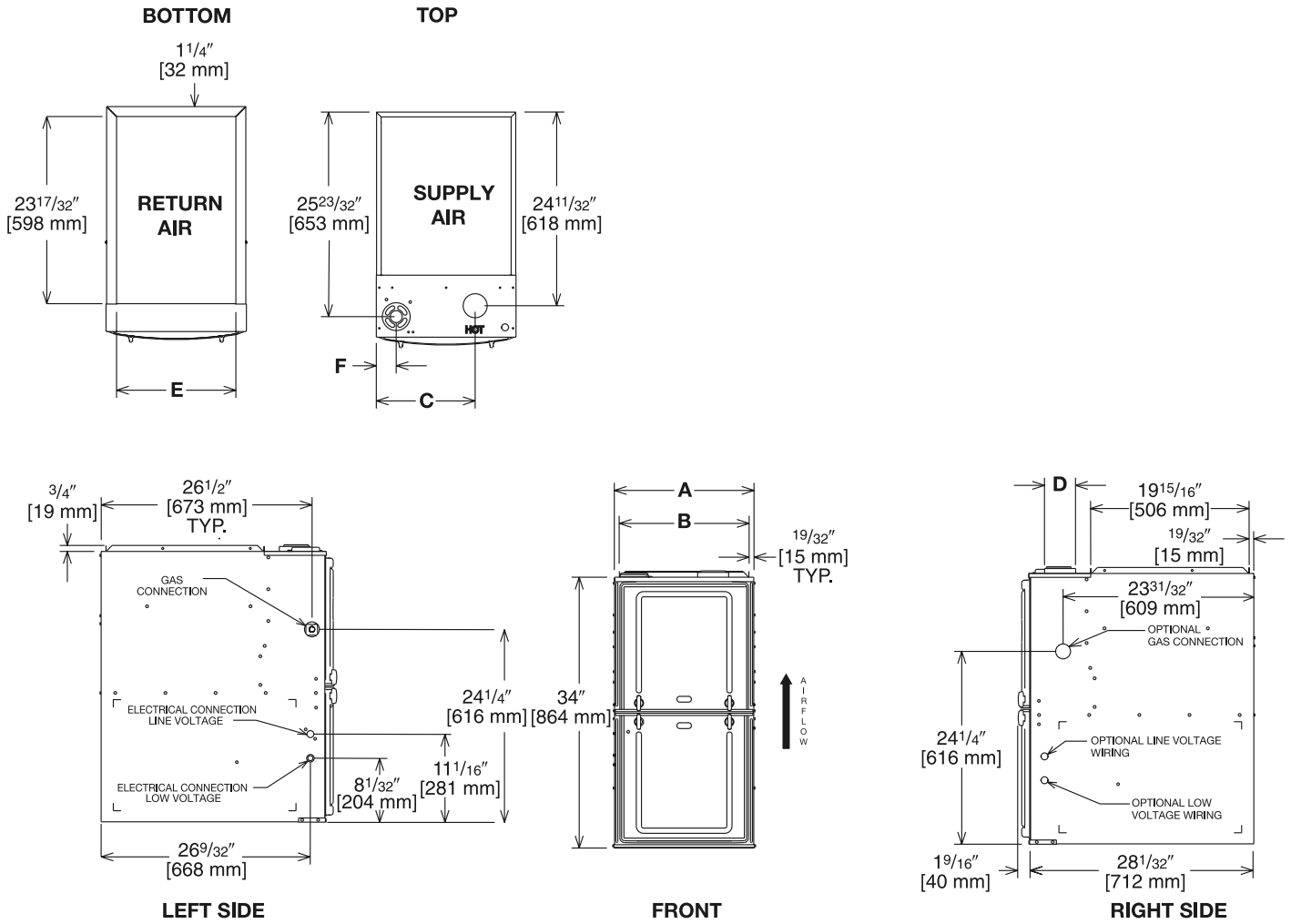

Illustration
ST-A1220-04-00
FIGURE 1

Dimensional Data: Upflow Model

MODEL R801V-	A	B	C	D	E	F	MINIMUM CLEARANCE (IN.) [mm]					
							LEFT SIDE	RIGHT SIDE	BACK	TOP	FRONT	VENT
503A14	14 [356]	12 ²⁷ / ₃₂ [326]	10 ⁵ / ₈ [270]	①	11 1/2 [292]	1 7/8 [48]	0	4 [102] ②	0	1 [25]	3 [76]	6 [152] ③
0504A17/ 754A17/1004A17	17 1/2 [445]	16 ¹¹ / ₃₂ [415]	12 ³ / ₈ [314]	①	15 [381]	2 1/2 [64]	0	3 [76] ②	0	1 [25]	3 [76]	6 [152] ③
0755A21/1005A21	21 [533]	19 ²⁷ / ₃₂ [504]	14 1/8 [359]	①	18 1/2 [470]	2 1/2 [64]	0	0	0	1 [25]	3 [76]	6 [152] ③
1255A24/1505A24	24 1/2 [622]	23 ¹¹ / ₃₂ [593]	15 7/8 [403]	①	22 [559]	2 1/2 [64]	0	0	0	1 [25]	3 [76]	6 [152] ③

NOTES: ① May require a 3" [76 mm] to 4" [102 mm] or 3" [76 mm] to 5" [127 mm] adapter.

② May be 0" [0 mm] with type B vent.

③ May be 1" [25 mm] with type B vent.

Furnaces must be vented in accordance with the National Fuel Gas Code, ANSI Z223.1 and in accordance with local codes.

[] Designates Metric Conversions

Horizontal Application

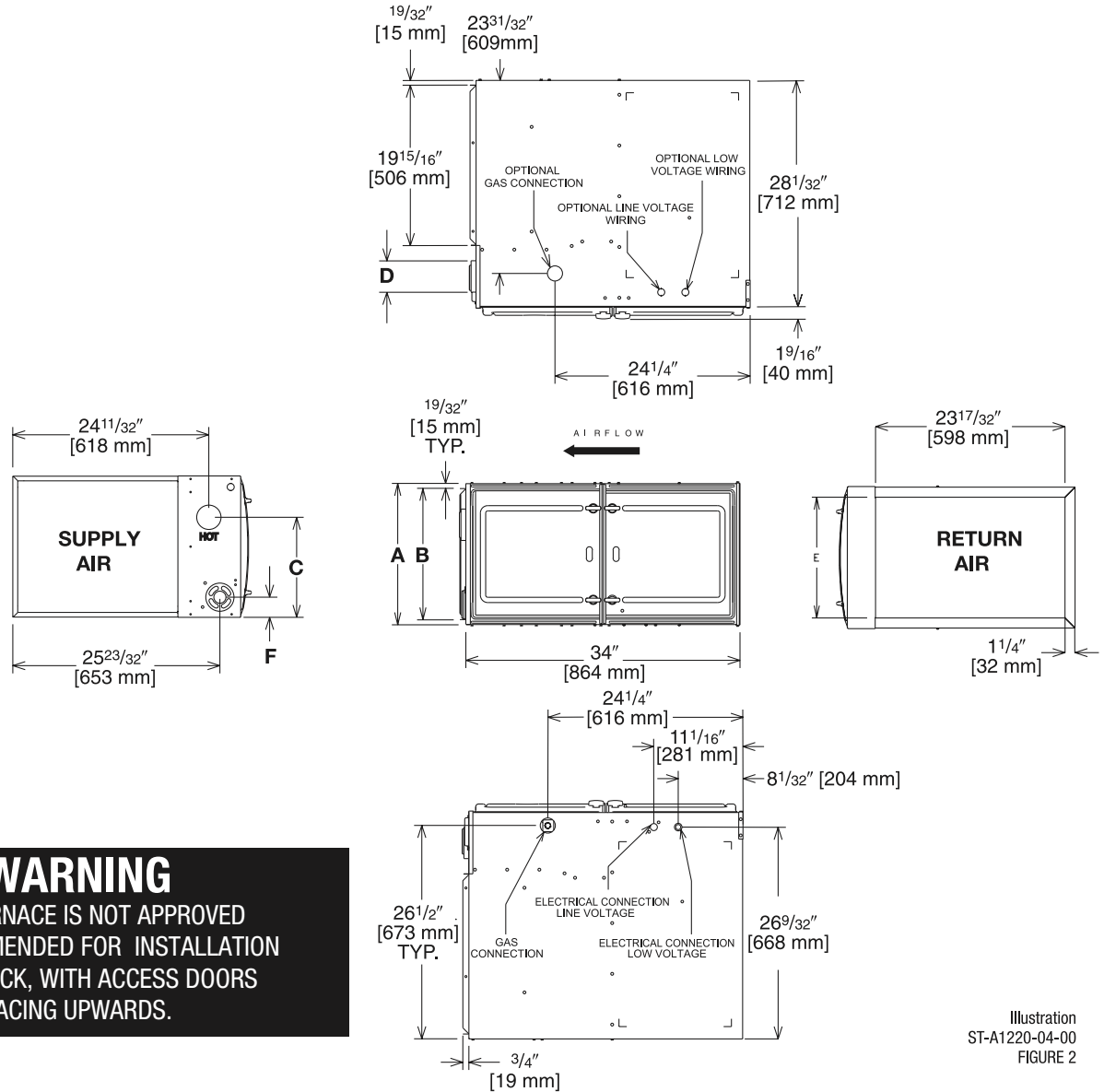

WARNING
THIS FURNACE IS NOT APPROVED
OR RECOMMENDED FOR INSTALLATION
ON ITS BACK, WITH ACCESS DOORS
FACING UPWARDS.

Illustration
ST-A1220-04-00
FIGURE 2

Dimensional Data: Horizontal Model

MODEL R801V-	A	B	C	D	E	F	MINIMUM CLEARANCE (IN.) [mm]					
							SUPPLY AIR SIDE	RETURN AIR SIDE	BACK	TOP	FRONT	VENT
0503A14	14 [356]	12 ²⁷ / ₃₂ [326]	10 ⁵ / ₈ [270]	①	11 ¹ / ₂ [292]	1 ⁷ / ₈ [48]	4 [102] ②	4 [102] ②	0	1 [25]	3 [76]	6 [152] ③
0504A17/ 0754A17/1004A17	17 ¹ / ₂ [445]	16 ¹¹ / ₃₂ [415]	12 ³ / ₈ [314]	①	15 [381]	2 ¹ / ₂ [64]	3 [76] ②	3 [76] ②	0	1 [25]	3 [76]	6 [152] ③
0755A21/1005A21	21 [533]	19 ²⁷ / ₃₂ [504]	14 ¹ / ₈ [359]	①	18 ¹ / ₂ [470]	2 ¹ / ₂ [64]	0	0	0	1 [25]	3 [76]	6 [152] ③
1255A24/1505A24	24 ¹ / ₂ [622]	23 ¹¹ / ₃₂ [593]	15 ⁷ / ₈ [403]	①	22 [559]	2 ¹ / ₂ [64]	0	0	0	1 [25]	3 [76]	6 [152] ③

NOTES: ① May require a 3" [76 mm] to 4" [102 mm] or 3" [76 mm] to 5" [127 mm] adapter.

② May be 0" [0 mm] with type B vent.

③ May be 1" [25 mm] with type B vent.

Furnaces must be vented in accordance with the National Fuel Gas Code, ANSI Z223.1 and in accordance with local codes.

[] Designates Metric Conversions

Blower Performance Data

TARGET GAS HEATING AIRFLOWS								
	R801V0503 A14UH*CAP	R801V0504 A17UH*CAP	R801V0754 A17UH*CAP	R801V0755 A21UH*CAP	R801V1004 A17UH*CAP	R801V1005 A21UH*CAP	R801V1255 A24UH*CAP	R801V1505 A24UH*CAP
Factory High Heating CFM [L/s]	960 [453]	930 [439]	1450 [684]	1425 [673]	1285 [606]	1550 [732]	1900 [897]	1850 [873]
High Heat Side Return CFM [L/s]	960 [453]	930 [439]	1450 [684]	1425 [673]	1325 [625]	1380 [651]	1900 [897]	1850 [873]
High Heat Approx. $\pm 7^{\circ}\text{F}$ CFM	864 [408]	837 [395]	1305 [616]	1283 [606]	1155 [545]	1395 [658]	1710 [807]	1655 [781]
High Heat Approx. $\pm 12^{\circ}\text{F}$ CFM	796 [376]	772 [364]	1204 [568]	1183 [558]	1065 [503]	1287 [607]	1577 [744]	1536 [725]

* S = Standard, N = Low NOx

[] Designates Metric Conversions

**BOTTOM RETURN FILTER RACK FOR
UPFLOW APPLICATION: RXGF-CB**

SIDE RETURN FILTER RACK: RXGF-CD

FILTER RACK FILTER SIZES* INCHES [mm]		
MODEL	RXGF-CB (UPFLOW/ HORIZONTAL)	RXGF-CD (UPFLOW) SIDE RETURN
R801V0503A14	12 ¹ / ₄ x 25 [311 x 635]	15 ³ / ₄ x 25 [400 x 635]
R801V0504A17/ R801V0754A17/R801V1004A17	15 ³ / ₄ x 25 [400 x 635]	15 ³ / ₄ x 25 [400 x 635]
R801V0755A21/R801V1005A21	19 ¹ / ₄ x 25 [489 x 635]	15 ³ / ₄ x 25 [400 x 635]
R801V1255A24/R801V1505A24	22 ³ / ₄ x 25 [578 x 635]	15 ³ / ₄ x 25 [400 x 635]

4" FLUE ADAPTER: RXGW-C01

Indoor Coil Casings

MODEL NUMBER
RXBC-D14AI
RXBC-D17AI
RXBC-D21AI
RXBC-D21BI
RXBC-D24AI

WARNING: IMPORTANT NOTICE

A SOLID METAL BASE PLATE (SEE TABLE) MUST BE IN PLACE WHEN THE FURNACE IS INSTALLED WITH SIDE AIR RETURN DUCTS. FAILURE TO INSTALL A BASE PLATE COULD CAUSE PRODUCTS OF COMBUSTION TO BE CIRCULATED INTO THE LIVING SPACE AND CREATE POTENTIALLY HAZARDOUS CONDITIONS.

FURNACE WIDTH IN. [mm]	SOLID BOTTOM KIT NO.	BASE PLATE NO.	BASE PLATE SIZE IN. [mm]
14 [356]	RXGB-D14	AE-61874-01	11 ⁵ / ₈ x 23 ⁹ / ₁₆ [295 x 598]
17 ¹ / ₂ [445]	RXGB-D17	AE-61874-02	15 ¹ / ₈ x 23 ⁹ / ₁₆ [384 x 598]
21 [533]	RXGB-D21	AE-61874-03	18 ⁵ / ₈ x 23 ⁹ / ₁₆ [473 x 598]
24 ¹ / ₂ [622]	RXGB-D24	AE-61874-04	25 ⁵ / ₈ x 23 ⁹ / ₁₆ [651 x 598]

For High Altitudes

OPTION CODE FOR HIGH ALTITUDE: U.S.

None required for high altitudes.

HIGH ALTITUDE CONVERSION KITS: U.S.

None required for high altitudes.

80+ HIGH ALTITUDE INSTRUCTIONS

CAUTION: Always follow National Fuel Gas Code (NFGC) guidelines when converting for high altitudes.

High altitude option codes are not required for these models. However, the burner orifice size needs to be recalculated and verified at elevations above 2000 ft. See Installation Instructions for more information.

L.P. CONVERSION KIT: RXGJ-FP15

[] Designates Metric Conversions

Integrated Controls



EcoNet® is smart, technology developed exclusively by Rheem that allows Heating, Cooling, and Water Heating products to communicate with each other on one integrated network.

THE ECONET® SMART THERMOSTAT

BUILT-IN WIFI

4.3" LCD TOUCH SCREEN

LOCAL WEATHER – Current conditions plus 6-day forecast

5 OPERATING MODES – Heat, Cool, Auto, Emergency Heat and Fan Only

7-DAY PROGRAMMABLE SCHEDULE – Offers comfort without thought

ONE-TOUCH AWAY – Quickly switch to your energy-saving away preferences

VACATION SCHEDULING – Allows you to save while you're away and come home to comfort

STANDBY SCREEN – Displays indoor temperature and current weather



RETST800SYS

OPERATIONAL FEATURES

AUTOMATIC CHANGEOVER – Transitions between heating and cooling automatically to keep the house comfortable

INTEGRATED WATER CONTROL – Enables easy water heater management

SMOOTH ARRIVAL – Prompts the system to start ahead of schedule to ensure the home is at the desired temperature at the scheduled time

HUMIDITY CONTROL – Supports humidifier accessories or over-cool based dehumidification

DETAILED OPERATING STATUS – View pertinent equipment status information and run times

CONTINUOUS FAN – Offers 5 speeds (Low, Medium Low, Medium, Medium High, High)

SHORT-CYCLE PROTECTION – Avoids damage to equipment from short run cycles

MONITORING & REMOTE CONTROL FEATURES

ACTIVE MONITORING – Alerts to problems that need immediate attention

REMOTE CONTROL – Allows adjusting of comfort and settings from anywhere using a mobile device

SERVICE ALERTS – Sends routine maintenance reminders

AIR FILTER MONITORING – Detects when it's time to replace the air filter

ALARM HISTORY – Displays time-stamped alarm codes with clear descriptions



The new degree of comfort®

GENERAL TERMS OF LIMITED WARRANTY*

Rheem will furnish a replacement for any part of this product which fails in normal use and service within the applicable period stated, in accordance with the terms of the limited warranty.

Conditional Parts
(Registration Required)..... Ten (10) Years
Heat Exchanger Twenty (20) Years

***For complete details of the Limited and Conditional Warranties, including applicable terms and conditions, contact your local contractor or the Manufacturer for a copy of the product warranty certificate.**

Before proceeding with installation, refer to installation instructions packaged with each model, as well as complying with all Federal, State, Provincial, and Local codes, regulations, and practices.

© 2024 Rheem Manufacturing Company. Rheem trademarks owned by Rheem Manufacturing Company.

In keeping with its policy of continuous progress and product improvement, Rheem reserves the right to make changes without notice.

5600 Old Greenwood Road
Fort Smith, Arkansas 72908 • www.rheem.com