



engineered for life™

Packaged Gas Electric  
RGE(A/X)YC Series

# Endeavor® Line *Classic Plus*® Series iR Residential Packaged Gas Electric Units



## RGE(A/X)YC

Nominal Sizes: 2 to 5 Tons [7.0 to 17.6 kW]

Cooling Efficiencies: 15.2 SEER2

Refrigerant Type: R-454B

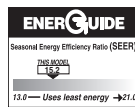

## TABLE OF CONTENTS

Unit Features & Benefits .....	3
Model Number Identification .....	4
Options .....	5
Dimensional Data.....	6-9
Typical Installations.....	10
General Data .....	11-16
General Data Notes.....	17
Gross Systems Performance Data .....	18-21
Airflow Performance Data .....	22
Electrical Data .....	23-26
Accessories.....	27-38
Limited Warranty.....	39



## FEATURES AND BENEFITS

- **Two-Stage Scroll Compressors on all models:** Modulates between two capacity settings — 67% and 100% — providing more precise temperature control, lower humidity and greater efficiency in comparison to single stage compressors. It uses 70% fewer moving parts which also increases efficiency and reliability
- **PlusOne® Diagnostics<sup>1</sup>:** The Rheem Contractor App and built-in EcoNet® & Bluetooth<sup>®2</sup> technology, makes monitoring, troubleshooting and repairing the product easier than ever before
- **Installation Commissioning via Bluetooth® Technology:** Seamless final install step without DIP switch configuration using the Rheem Contractor App.
- **On-demand Dehumidification:** Available through EcoNet® thermostat
- **MicroChannel Evaporator and Condenser Coil:** Delivers superior performance with less refrigerant charge and less weight than conventional copper tube/aluminum fin coils. All aluminum construction has superior protection against formicary corrosion and aluminum tube rubbing potential. It is easier to clean and has a more robust surface
- **Constant Volume Motor:** Truly variable speed technology allows for ultimate humidity control, quieter sound levels and year-round energy savings
- **Dedicated Heating Speeds:** Maintain consistent performance via Constant CFM motor to keep temp rise at a comfortable level
- **Thermal Expansion Valves:** Standard on all models for precise superheat control, reliability, and energy efficiency at all operating conditions
- **High and Low Pressure Control:** Standard on all models for refrigerant component protection and reliability
- **Filter Drier:** Standard on all models
- **100% Factory Run Tested**
- **Stainless Steel Heat Exchanger:** Available as factory installed option for better corrosion resistance
- **PlusOne® Ignition System:** Proven Direct Spark Ignition System (DSI) for reliability and longevity
- **PlusOne® Refrigerant Detection System<sup>TM3</sup>:** An integrated one-box, patented design featuring the A2L sensor and mitigation board, offering easier commissioning with a single component and simplified wiring configuration, compatibility with any 24V thermostat application and system protection by automatically pausing outdoor unit operation – if excess refrigerant is detected
- **Rugged Base Rail:** For improved installation and handling.
- **Easily Accessible Control Box, Furnace Compartment and Slide-Out Blower Section:** Allows for installability and serviceability
- **Side and Down Discharge Options Available:** All models are shipped ready for horizontal applications
- **Double Sloped Evaporator Coil Drain Pan:** Allows for complete water removal from the unit — contributing to improved indoor air quality
- **Louvered Condenser Compartment:** Protects the coil against yard hazards and/or weather extremes
- **Supply and Return Air Openings:** Feature a one-inch-tall flange to prevent water migration into the ductwork

<sup>1</sup>Bluetooth functionality applies to the heating section only. <sup>2</sup>The Bluetooth® word mark and logos are registered trademarks owned by Bluetooth SIG, Inc. and any use of such marks by Rheem® is under license. Other trademarks and trade names are those of their respective owners. <sup>3</sup>Factory installed on 3.5, 4 and 5 ton models. For R-454B equipment with a refrigerant charge less than 3.9 lbs (≈1.8 kg or ≈62.6 oz), a refrigerant detection system is not required by the UL 60335-2-40 standard.

## Packaged Gas Electric

<u>R</u>	<u>GE</u>	<u>A</u>	<u>Y</u>	<u>C</u>	<u>024</u>	<u>A</u>	<u>J</u>	<u>V</u>	<u>06</u>	<u>2</u>	<u>C</u>	<u>A</u>
Brand	Product Category	Platform	Refrigerant	Tier	Capacity BTU/HR	Major Series	Voltage	Drive	Gas Heat Input	Gas Heat Configuration	Control	Minor Series
R - Rheem	GE - Gas Electric	A - Resipack Convertible X - Resipack Convertible	Y - R454B	C - Mid Tier (15.2 SEER2)	024 - 24,000 [7.03 kW] 036 - 36,000 [10.55 kW] 048 - 48,000 [14.07 kW] 060 - 60,000 [17.58 kW]	A - 1st Design	J - 1ph, 208 - 230/60 C - 3ph, 208 - 230/60 D - 3ph, 460/60	V - Constant Volume	06 - 60K BTU/H 08 - 80K BTU/H 10 - 100K BTU/H	2 - Two Stage T - Two Stage Low NOx	C - Communicating	A - 1st Design

[ ] Designates Metric Conversions

AVAILABLE MODELS	
Standard	Low NOx (40ng/J)
RGEAYC024AJV062CA	RGEAYC024AJV06TCA
RGEAYC024ACV062CA	RGEAYC024ACV06TCA
RGEAYC036AJV062CA	RGEAYC036AJV06TCA
RGEAYC036AJV082CA	RGEAYC036AJV08TCA
RGEAYC036AJV102CA	RGEAYC036AJV10TCA
RGEAYC036ACV062CA	RGEAYC036ACV06TCA
RGEAYC036ACV082CA	RGEAYC036ACV08TCA
RGEAYC036ACV102CA	RGEAYC036ACV10TCA
RGEAYC036ADV062CA	RGEAYC036ADV06TCA
RGEAYC036ADV082CA	RGEAYC036ADV08TCA
RGEAYC036ADV102CA	RGEAYC036ADV10TCA
RGEXYC048AJV082CA	RGEXYC048AJV08TCA
RGEXYC048AJV102CA	RGEXYC048AJV10TCA
RGEXYC048ACV082CA	RGEXYC048ACV08TCA
RGEXYC048ACV102CA	RGEXYC048ACV10TCA
RGEXYC048ADV082CA	RGEXYC048ADV08TCA
RGEXYC048ADV102CA	RGEXYC048ADV10TCA
RGEXYC060AJV082CA	RGEXYC060AJV08TCA
RGEXYC060AJV102CA	RGEXYC060AJV10TCA
RGEXYC060ACV082CA	RGEXYC060ACV08TCA
RGEXYC060ACV102CA	RGEXYC060ACV10TCA
RGEXYC060ADV082CA	RGEXYC060ADV08TCA
RGEXYC060ADV102CA	RGEXYC060ADV10TCA

**NOTE:** All models feature two stage cooling and heating. Stainless steel heat exchanger option is available on standard and Low NOx models.

## Instructions for Factory-Installed Option(s) Selection

**Note:** Three characters following the model number will be utilized to designate a factory-installed option or combination of options. If no factory option(s) is required, nothing follows the model number.

After a basic rooftop model is selected, choose a *three-character* option code from the FACTORY-INSTALLED OPTION SELECTION TABLE.

### FACTORY INSTALLED OPTION CODES

Option Code	Stainless Steel Heat Exchanger
AJA	x

"x" indicates factory installed option.

Example: No Option

RGEAYC036AJV082CA

Example: Option with Stainless Steel Heat Exchanger

RGEAYC036AJV082CAAJA

**NOTES:** Factory installed economizer is not available.

# UNIT DIMENSIONS

## RGEAYC

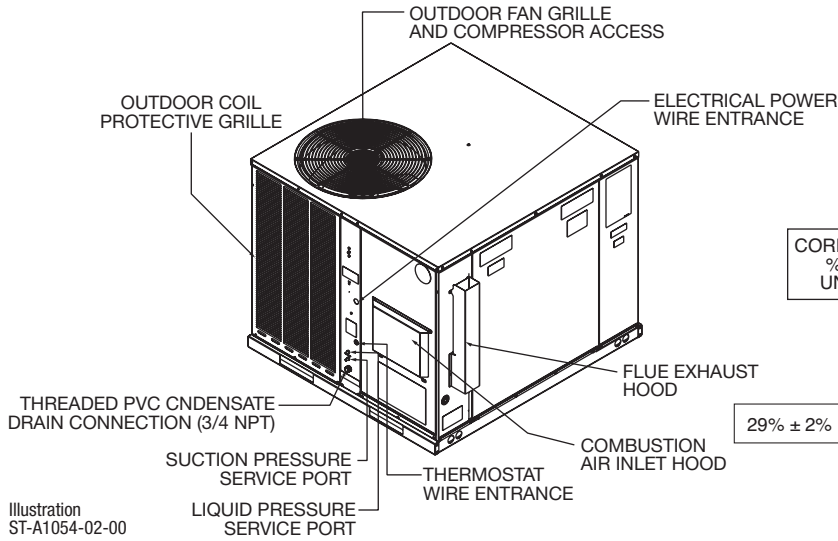
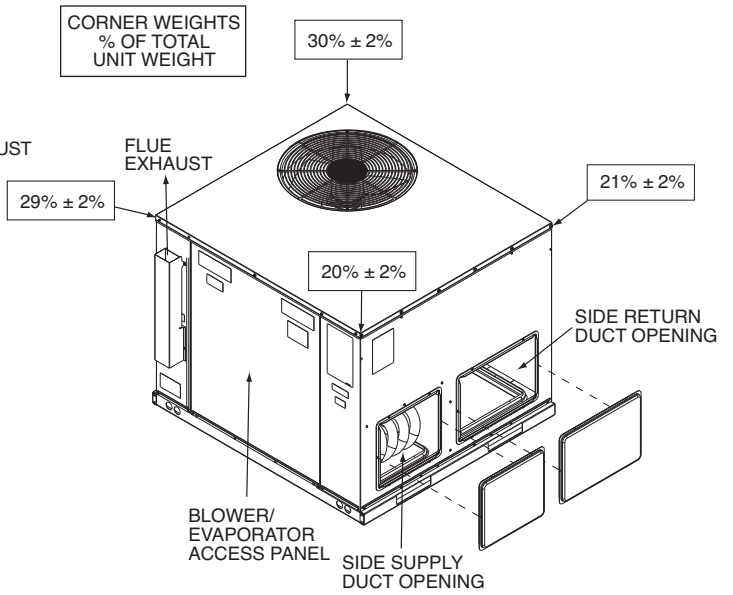
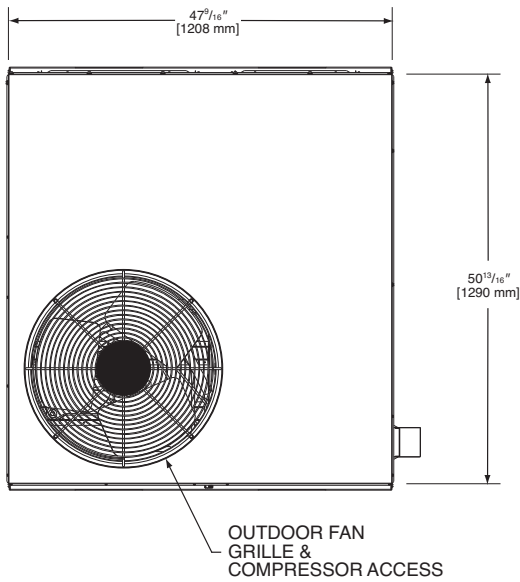

Illustration  
ST-A1054-02-00



### TOP VIEW



### BOTTOM VIEW

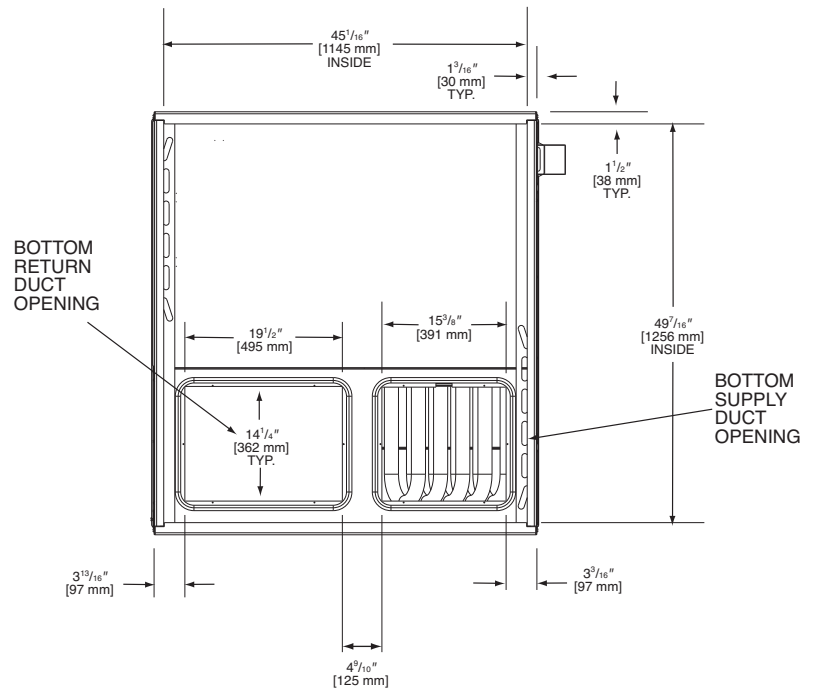

[ ] Designates Metric Conversions

### SIDE VIEW

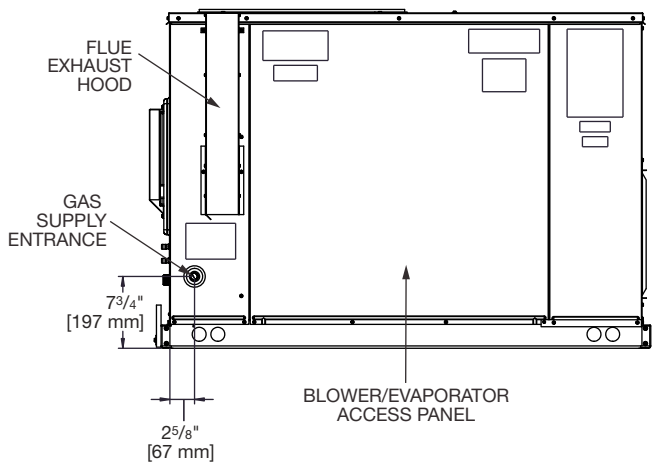

### SIDE VIEW

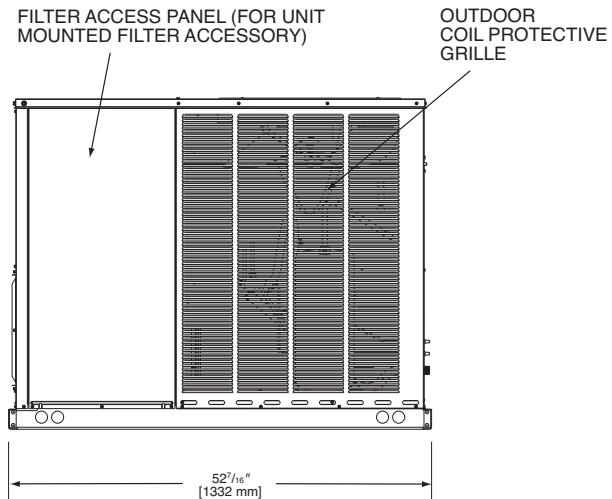

### FRONT VIEW

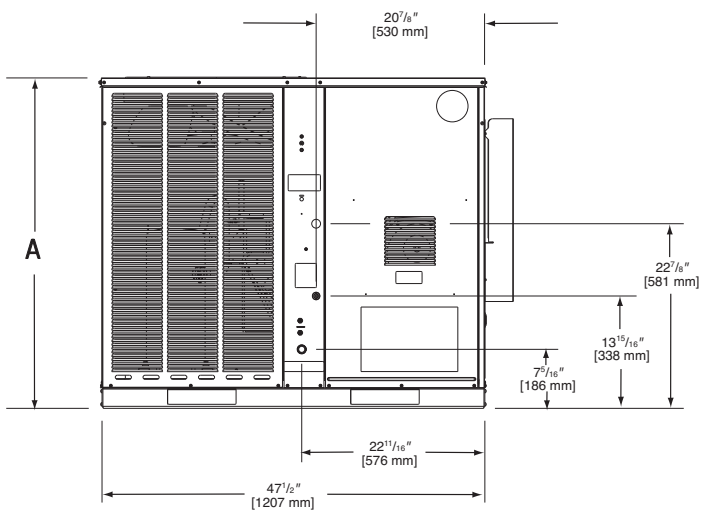

### BACK VIEW

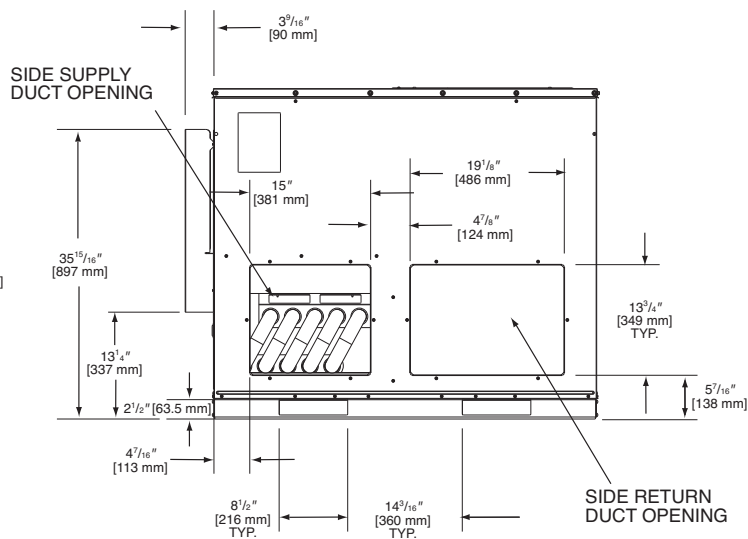

SHOWN WITH DUCT COVERS REMOVED.

Models RGEAYC	Height "A"
024	35 <sup>15</sup> / <sub>16</sub> "
036	41"

[ ] Designates Metric Conversions

# UNIT DIMENSIONS

## RGEXYC

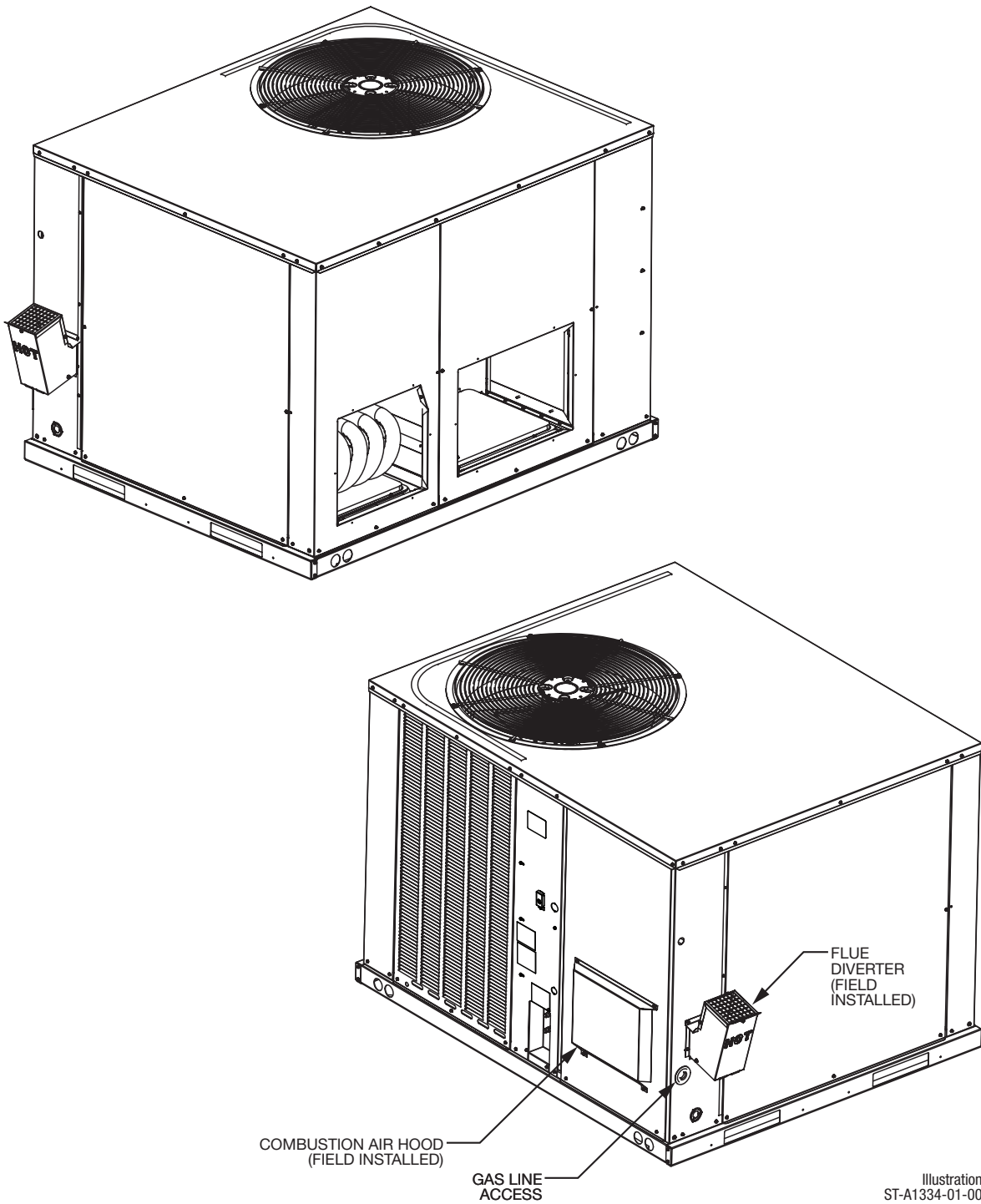

[ ] Designates Metric Conversions



**TOP VIEW**

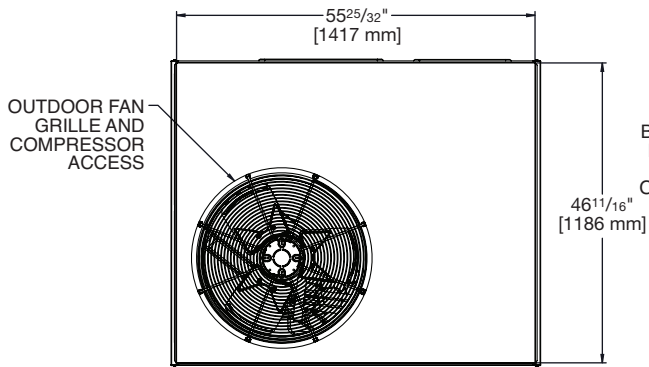

**BOTTOM VIEW**

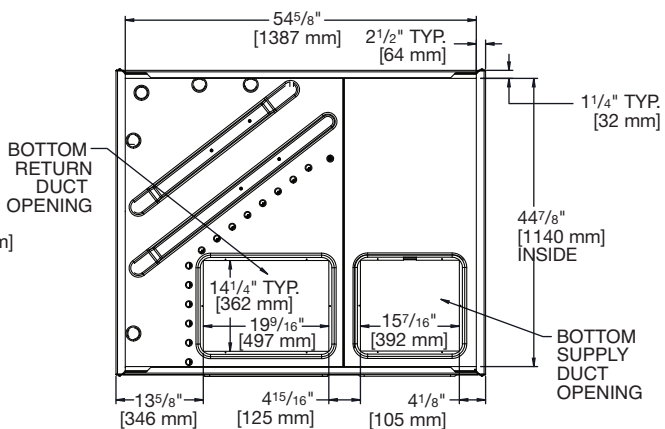

**SIDE VIEW**

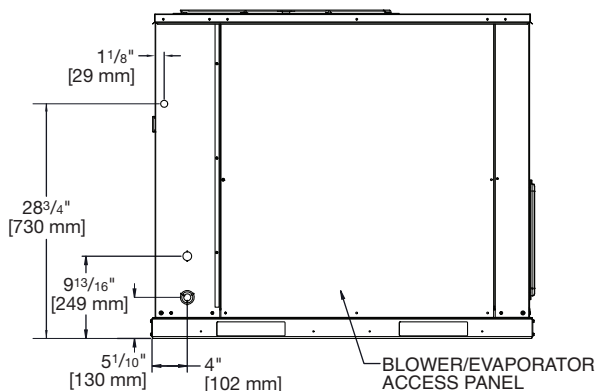

**SIDE VIEW**

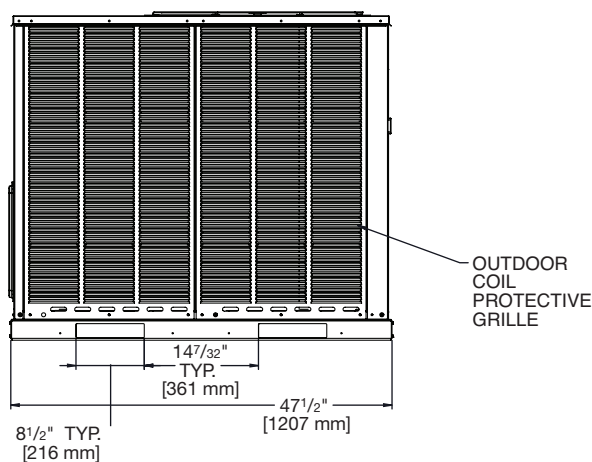

**FRONT VIEW**

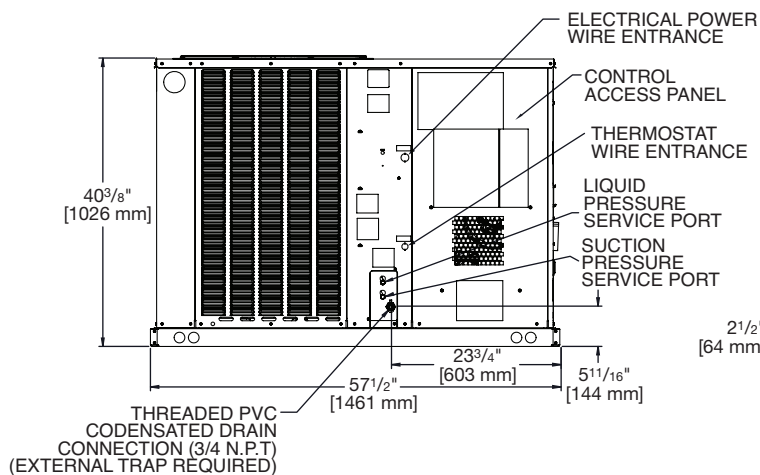

**REAR VIEW**

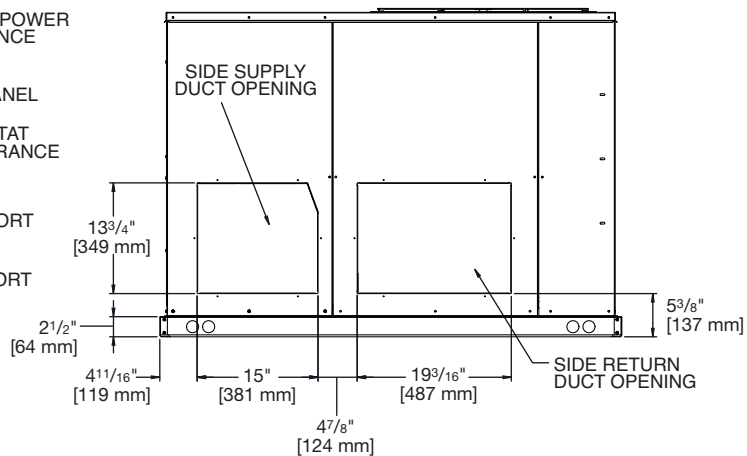

ST-A1334-02-00

Models RGEXYC	Height "A"
048, 060	41"

[ ] Designates Metric Conversions

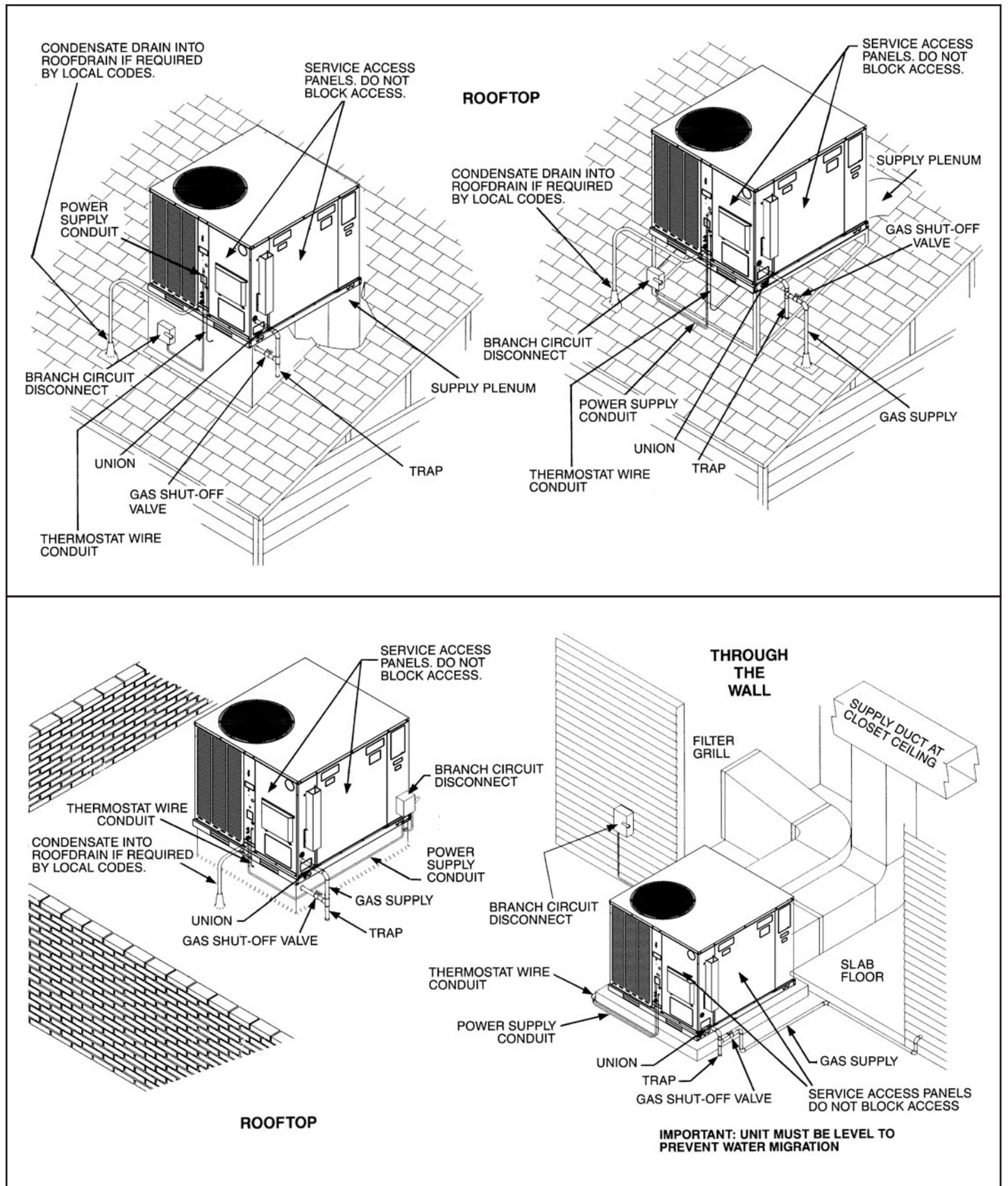

[ ] Designates Metric Conversions

## NOMINAL SIZES 2-3 TONS [7.0-10.5 kW]

Model RGEXYC Series	024ACV062	024AJV062	036ACV062	036ACV082
<b>Cooling Performance<sup>1</sup></b>				<b>CONTINUED</b> →
Gross Cooling Capacity Btu/h [kW]	24,200 [7.09]	24,200 [7.09]	35,800 [10.49]	35,800 [10.49]
EER2/SEER2 <sup>2</sup>	11.5/15.2	11.5/15.2	11.5/15.2	11.5/15.2
Nominal CFM/AHRI Rated CFM [L/s]	800/815 [378/385]	800/815 [378/385]	1200/1200 [566/566]	1200/1200 [566/566]
AHRI Net Cooling Capacity Btu/h [kW]	22,800 [6.68]	22,800 [6.68]	34,200 [10.02]	34,200 [10.02]
Net Sensible Capacity Btu/h [kW]	16,600 [4.86]	16,600 [4.86]	25,800 [7.56]	25,800 [7.56]
Net Latent Capacity Btu/h [kW]	6,800 [1.99]	6,800 [1.99]	9,200 [2.7]	9,200 [2.7]
Net System Power kW	1.92	1.92	2.98	2.98
<b>Heating Performance (Gas)<sup>3</sup></b>				
Heating Input Btu/h [kW] (1st Stage/2nd Stage)	42,000/60,000	42,000/60,000 [12.30/17.58]	42,000/60,000	56,000/80,000 [16.41/23.44]
Heating Output Btu/h [kW] (1st Stage/2nd Stage)	34,020/48,600 [9.97/14.24]	34,020/48,600 [9.97/14.24]	34,020/48,600 [9.97/14.24]	45,360/64,800 [13.29/18.99]
Temperature Rise Range °F [°C] (1st Stage/2nd Stage)	20-50 [11.1-27.7] / 30-60 [16.6-33.3]	20-50 [11.1-27.7] / 30-60 [16.6-33.3]	20-50 [11.1-27.7] / 30-60 [16.6-33.3]	25-55 [13.8-30.5] / 35-65 [19.4-36.1]
AFUE % <sup>4</sup>	NA	81	NA	NA
Steady State Efficiency (%)	81	NA	81	81
No. Burners	3	3	3	4
No. Stages	2	2	2	2
Gas Connection Pipe Size in. [mm]	0.5 [12.7]	0.5 [12.7]	0.5 [12.7]	0.5 [12.7]
<b>Compressor</b>				
No./Type	1/2/Scroll	1/2/Scroll	1/2/Scroll	1/2/Scroll
<b>Outdoor Sound Rating (dB)<sup>5</sup></b>	74	74	71	71
<b>Outdoor Coil - Fin Type</b>	Louvered	Louvered	Louvered	Louvered
Tube Type	MicroChannel	MicroChannel	MicroChannel	MicroChannel
MicroChannel Depth in. [mm]	0.709 [18]	0.709 [18]	0.472 [12]	0.472 [12]
Face Area sq. ft. [sq. m]	9.77 [0.91]	9.77 [0.91]	16.26 [1.51]	16.26 [1.51]
Rows/FPI [FPcm]	1/23 [9]	1/23 [9]	1/23 [9]	1/23 [9]
<b>Indoor Coil - Fin Type</b>	Louvered	Louvered	Louvered	Louvered
Tube Type	MicroChannel	MicroChannel	MicroChannel	MicroChannel
MicroChannel Depth in. [mm]	1 [25.4]	1 [25.4]	1 [25.4]	1 [25.4]
Face Area sq. ft. [sq. m]	3.54 [0.33]	3.54 [0.33]	4 [0.37]	4 [0.37]
Rows/FPI [FPcm]	1/20 [8]	1/20 [8]	1/20 [8]	1/20 [8]
Refrigerant Control	TX Valves	TX Valves	TX Valves	TX Valves
Drain Connection No./Size in. [mm]	1/0.75 [19.05]	1/0.75 [19.05]	1/0.75 [19.05]	1/0.75 [19.05]
<b>Outdoor Fan - Type</b>	Propeller	Propeller	Propeller	Propeller
No. Used/Diameter in. [mm]	1/22 [558.8]	1/22 [558.8]	1/22 [558.8]	1/22 [558.8]
Drive Type/No. Speeds	Direct/1	Direct/1	Direct/1	Direct/1
CFM [L/s]	2500 [1180]	2500 [1180]	3250 [1534]	3250 [1534]
No. Motors/HP	1 at 1/6 HP	1 at 1/6 HP	1 at 1/3 HP	1 at 1/3 HP
Motor RPM	825	825	825	825
<b>Indoor Fan - Type</b>	FC Centrifugal	FC Centrifugal	FC Centrifugal	FC Centrifugal
No. Used/Diameter in. [mm]	1/10x9 [254x229]	1/10x9 [254x229]	1/12x9 [305x229]	1/12x9 [305x229]
Drive Type	Direct	Direct	Direct	Direct
No. Speeds	Multiple	Multiple	Multiple	Multiple
No. Motors	1	1	1	1
Motor HP	1/3	1/3	1	1
Motor RPM	1050	1050	1050	1050
Motor Frame Size	48	48	48	48
<b>Filter - Type</b>	Field Supplied	Field Supplied	Field Supplied	Field Supplied
Furnished	No	No	No	No
(NO.) Size Recommended in. [mm x mm x mm]	(1)1x24x24 [25x610x610]	(1)1x24x24 [25x610x610]	(1)1x24x24 [25x610x610]	(1)1x24x24 [25x610x610]
<b>Refrigerant Charge Oz. [g]</b>	47 [1332]	47 [1332]	53 [1503]	53 [1503]
<b>Weights</b>				
Net Weight lbs. [kg]	408 [185]	408 [185]	440 [200]	445 [202]
Ship Weight lbs. [kg]	418 [189]	418 [189]	450 [204]	455 [206]

See Page 17 for Notes.

[ ] Designates Metric Conversions

## NOMINAL SIZES 2-3 TONS [7.0-10.5 kW]

Model RGEYC Series	036ACV102	036ADV062	036ADV082	036ADV102
<b>Cooling Performance<sup>1</sup></b>				<b>CONTINUED</b> →
Gross Cooling Capacity Btu/h [kW]	35,800 [10.49]	35,800 [10.49]	35,800 [10.49]	35,800 [10.49]
EER2/SEER2 <sup>2</sup>	11.5/15.2	11.5/15.2	11.5/15.2	11.5/15.2
Nominal CFM/AHRI Rated CFM [L/s]	1200/1200 [566/566]	1200/1200 [566/566]	1200/1200 [566/566]	1200/1200 [566/566]
AHRI Net Cooling Capacity Btu/h [kW]	34,200 [10.02]	34,200 [10.02]	34,200 [10.02]	34,200 [10.02]
Net Sensible Capacity Btu/h [kW]	25,800 [7.56]	25,800 [7.56]	25,800 [7.56]	25,800 [7.56]
Net Latent Capacity Btu/h [kW]	9,200 [2.7]	9,200 [2.7]	9,200 [2.7]	9,200 [2.7]
Net System Power kW	2.98	2.98	2.98	2.98
<b>Heating Performance (Gas)<sup>3</sup></b>				
Heating Input Btu/h [kW] (1st Stage/2nd Stage)	70,000/100,000 [20.51/29.3]	42,000/60,000 [12.30/17.58]	56,000/80,000 [16.41/23.44]	70,000/100,000 [20.51/29.3]
Heating Output Btu/h [kW] (1st Stage/2nd Stage)	56,700/81,000 [16.61/23.73]	34,020/48,600 [9.97/14.24]	45,360/64,800 [13.29/18.99]	56,700/81,000 [16.61/23.73]
Temperature Rise Range °F [°C] (1st Stage/2nd Stage)	35-65 [19.4-36.1] / 45-75 [25-41.6]	20-50 [11.1-27.7] / 30-60 [16.6-33.3]	25-55 [13.8-30.5] / 35-65 [19.4-36.1]	35-65 [19.4-36.1] / 45-75 [25-41.6]
AFUE % <sup>4</sup>	NA	NA	NA	NA
Steady State Efficiency (%)	81	81	81	81
No. Burners	5	3	4	5
No. Stages	2	2	2	2
Gas Connection Pipe Size in. [mm]	0.5 [12.7]	0.5 [12.7]	0.5 [12.7]	0.5 [12.7]
<b>Compressor</b>				
No./Type	1/2/Scroll	1/2/Scroll	1/2/Scroll	1/2/Scroll
<b>Outdoor Sound Rating (dB)<sup>5</sup></b>	71	71	71	71
<b>Outdoor Coil - Fin Type</b>	Louvered	Louvered	Louvered	Louvered
Tube Type	MicroChannel	MicroChannel	MicroChannel	MicroChannel
MicroChannel Depth in. [mm]	0.472 [12]	0.472 [12]	0.472 [12]	0.472 [12]
Face Area sq. ft. [sq. m]	16.26 [1.51]	16.26 [1.51]	16.26 [1.51]	16.26 [1.51]
Rows/FPI [FPcm]	1/23 [9]	1/23 [9]	1/23 [9]	1/23 [9]
<b>Indoor Coil - Fin Type</b>	Louvered	Louvered	Louvered	Louvered
Tube Type	MicroChannel	MicroChannel	MicroChannel	MicroChannel
MicroChannel Depth in. [mm]	1 [25.4]	1 [25.4]	1 [25.4]	1 [25.4]
Face Area sq. ft. [sq. m]	4 [0.37]	4 [0.37]	4 [0.37]	4 [0.37]
Rows/FPI [FPcm]	1/20 [8]	1/20 [8]	1/20 [8]	1/20 [8]
Refrigerant Control	TX Valves	TX Valves	TX Valves	TX Valves
Drain Connection No./Size in. [mm]	1/0.75 [19.05]	1/0.75 [19.05]	1/0.75 [19.05]	1/0.75 [19.05]
<b>Outdoor Fan - Type</b>	Propeller	Propeller	Propeller	Propeller
No. Used/Diameter in. [mm]	1/22 [558.8]	1/22 [558.8]	1/22 [558.8]	1/22 [558.8]
Drive Type/No. Speeds	Direct/1	Direct/1	Direct/1	Direct/1
CFM [L/s]	3250 [1534]	3250 [1534]	3250 [1534]	3250 [1534]
No. Motors/HP	1 at 1/3 HP	1 at 1/3 HP	1 at 1/3 HP	1 at 1/3 HP
Motor RPM	825	825	825	825
<b>Indoor Fan - Type</b>	FC Centrifugal	FC Centrifugal	FC Centrifugal	FC Centrifugal
No. Used/Diameter in. [mm]	1/12x9 [305x229]	1/12x9 [305x229]	1/12x9 [305x229]	1/12x9 [305x229]
Drive Type	Direct	Direct	Direct	Direct
No. Speeds	Multiple	Multiple	Multiple	Multiple
No. Motors	1	1	1	1
Motor HP	1	1	1	1
Motor RPM	1050	1050	1050	1050
Motor Frame Size	48	48	48	48
<b>Filter - Type</b>	Field Supplied	Field Supplied	Field Supplied	Field Supplied
Furnished	No	No	No	No
(NO.) Size Recommended in. [mm x mm x mm]	(1)1x24x24 [25x610x610]	(1)1x24x24 [25x610x610]	(1)1x24x24 [25x610x610]	(1)1x24x24 [25x610x610]
<b>Refrigerant Charge Oz. [g]</b>	53 [1503]	53 [1503]	53 [1503]	53 [1503]
<b>Weights</b>				
Net Weight lbs. [kg]	450 [204]	440 [200]	445 [202]	450 [204]
Ship Weight lbs. [kg]	460 [209]	450 [204]	455 [206]	460 [209]

See Page 17 for Notes.

[ ] Designates Metric Conversions

## NOMINAL SIZES 2-3 TONS [7.0-10.5 kW]

Model RGEAYC Series	036AJV062	036AJV082	036AJV102
<b>Cooling Performance<sup>1</sup></b>			
Gross Cooling Capacity Btu/h [kW]	35,800 [10.49]	35,800 [10.49]	35,800 [10.49]
EER2/SEER2 <sup>2</sup>	11.5/15.2	11.5/15.2	11.5/15.2
Nominal CFM/AHRI Rated CFM [L/s]	1200/1200 [566/566]	1200/1200 [566/566]	1200/1200 [566/566]
AHRI Net Cooling Capacity Btu/h [kW]	34,200 [10.02]	34,200 [10.02]	34,200 [10.02]
Net Sensible Capacity Btu/h [kW]	25,800 [7.56]	25,800 [7.56]	25,800 [7.56]
Net Latent Capacity Btu/h [kW]	9,200 [2.7]	9,200 [2.7]	9,200 [2.7]
Net System Power kW	2.98	2.98	2.98
<b>Heating Performance (Gas)<sup>3</sup></b>			
Heating Input Btu/h [kW]	42,000/60,000 [12.30/17.58]	56,000/80,000 [16.41/23.44]	70,000/100,000 [20.51/29.3]
Heating Output Btu/h [kW]	34,020/48,600 [9.97/14.24]	45,360/64,800 [13.29/18.99]	56,700/81,000 [16.61/23.73]
Temperature Rise Range °F [°C]	20-50 [11.1-27.7] / 30-60 [16.6-33.3]	25-55 [13.8-30.5] / 35-65 [19.4-36.1]	35-65 [19.4-36.1] / 45-75 [25-41.6]
AFUE % <sup>4</sup>	81	81	81
Steady State Efficiency (%)	NA	NA	NA
No. Burners	3	4	5
No. Stages	2	2	2
Gas Connection Pipe Size in. [mm]	0.5 [12.7]	0.5 [12.7]	0.5 [12.7]
<b>Compressor</b>			
No./Type	1/2/Scroll	1/2/Scroll	1/2/Scroll
<b>Outdoor Sound Rating (dB)<sup>5</sup></b>			
	71	71	71
<b>Outdoor Coil - Fin Type</b>			
Tube Type	Louvered	Louvered	Louvered
MicroChannel Depth in. [mm]	MicroChannel	MicroChannel	MicroChannel
Face Area sq. ft. [sq. m]	0.472 [12]	0.472 [12]	0.472 [12]
Rows/FPI [FPcm]	16.26 [1.51]	16.26 [1.51]	16.26 [1.51]
	1/23 [9]	1/23 [9]	1/23 [9]
<b>Indoor Coil - Fin Type</b>			
Tube Type	Louvered	Louvered	Louvered
MicroChannel Depth in. [mm]	MicroChannel	MicroChannel	MicroChannel
Face Area sq. ft. [sq. m]	1 [25.4]	1 [25.4]	1 [25.4]
Rows/FPI [FPcm]	4 [0.37]	4 [0.37]	4 [0.37]
Refrigerant Control	1/20 [8]	1/20 [8]	1/20 [8]
Drain Connection No./Size in. [mm]	TX Valves	TX Valves	TX Valves
	1/0.75 [19.05]	1/0.75 [19.05]	1/0.75 [19.05]
<b>Outdoor Fan - Type</b>			
No. Used/Diameter in. [mm]	Propeller	Propeller	Propeller
Drive Type/No. Speeds	1/22 [558.8]	1/22 [558.8]	1/22 [558.8]
CFM [L/s]	Direct/1	Direct/1	Direct/1
No. Motors/HP	3250 [1534]	3250 [1534]	3250 [1534]
Motor RPM	1 at 1/3 HP	1 at 1/3 HP	1 at 1/3 HP
	825	825	825
<b>Indoor Fan - Type</b>			
No. Used/Diameter in. [mm]	FC Centrifugal	FC Centrifugal	FC Centrifugal
Drive Type	1/12x9 [305x229]	1/12x9 [305x229]	1/12x9 [305x229]
No. Speeds	Direct	Direct	Direct
No. Motors	Multiple	Multiple	Multiple
Motor HP	1	1	1
Motor RPM	1	1	1
Motor Frame Size	1050	1050	1050
	48	48	48
<b>Filter - Type</b>			
Furnished	Field Supplied	Field Supplied	Field Supplied
(NO.) Size Recommended in. [mm x mm x mm]	No	No	No
	(1)1x24x24 [25x610x610]	(1)1x24x24 [25x610x610]	(1)1x24x24 [25x610x610]
<b>Refrigerant Charge Oz. [g]</b>			
	53 [1503]	53 [1503]	53 [1503]
<b>Weights</b>			
Net Weight lbs. [kg]	440 [200]	445 [202]	450 [204]
Ship Weight lbs. [kg]	450 [204]	455 [206]	460 [209]

See Page 17 for Notes.

[ ] Designates Metric Conversions



## NOMINAL SIZES 4-5 TONS [14-17.6 kW]

Model RGEYC Series	048ACV08	048ACV10	048ADV08	048ADV10
<b>Cooling Performance<sup>1</sup></b>				<b>CONTINUED</b> →
Gross Cooling Capacity Btu/h [kW]	48,500 [14.21]	48,500 [14.21]	48,500 [14.21]	48,500 [14.21]
EER2/SEER2 <sup>2</sup>	11.5/15.2	11.5/15.2	11.5/15.2	11.5/15.2
Nominal CFM/AHRI Rated CFM [L/s]	1600/1525 [755/720]	1600/1525 [755/720]	1600/1525 [755/720]	1600/1525 [755/720]
AHRI Net Cooling Capacity Btu/h [kW]	45,500 [13.33]	45,500 [13.33]	45,500 [13.33]	45,500 [13.33]
Net Sensible Capacity Btu/h [kW]	33,300 [9.76]	33,300 [9.76]	33,300 [9.76]	33,300 [9.76]
Net Latent Capacity Btu/h [kW]	14,200 [4.16]	14,200 [4.16]	14,200 [4.16]	14,200 [4.16]
Net System Power kW	3.9	3.9	3.9	3.9
<b>Heating Performance (Gas)<sup>3</sup></b>				
Heating Input Btu/h [kW] (1st Stage/2nd Stage)	56,000/80,000 [16.41/23.44]	70,000/100,000 [20.51/29.3]	56,000/80,000 [16.41/23.44]	70,000/100,000 [20.51/29.3]
Heating Output Btu/h [kW] (1st Stage/2nd Stage)	45,360/64,800 [13.29/18.99]	56,700/81,000 [16.61/23.73]	45,360/64,800 [13.29/18.99]	56,700/81,000 [16.61/23.73]
Temperature Rise Range °F [°C] (1st Stage/2nd Stage)	25-55 [13.9-30.6]/ 35-65 [19.4-36.1]	25-55 [13.9-30.6]/ 35-65 [19.4-36.1]	25-55 [13.9-30.6]/ 35-65 [19.4-36.1]	25-55 [13.9-30.6]/ 35-65 [19.4-36.1]
AFUE % <sup>4</sup>	NA	NA	NA	NA
Steady State Efficiency (%)	81	81	81	81
No. Burners	4	5	4	5
No. Stages	2	2	2	2
Gas Connection Pipe Size in. [mm]	0.5 [12.7]	0.5 [12.7]	0.5 [12.7]	0.5 [12.7]
<b>Compressor</b>				
No./Type	1/2/Scroll	1/2/Scroll	1/2/Scroll	1/2/Scroll
<b>Outdoor Sound Rating (dB)<sup>5</sup></b>	81	81	81	81
<b>Outdoor Coil - Fin Type</b>	Louvered	Louvered	Louvered	Louvered
Tube Type	MicroChannel	MicroChannel	MicroChannel	MicroChannel
MicroChannel Depth in. [mm]	1 [25.4]	1 [25.4]	1 [25.4]	1 [25.4]
Face Area sq. ft. [sq. m]	15.98 [1.48]	15.98 [1.48]	15.98 [1.48]	15.98 [1.48]
Rows/FPI [FPcm]	1 / 23 [9]	1 / 23 [9]	1 / 23 [9]	1 / 23 [9]
<b>Indoor Coil - Fin Type</b>	Louvered	Louvered	Louvered	Louvered
Tube Type	MicroChannel	MicroChannel	MicroChannel	MicroChannel
MicroChannel Depth in. [mm]	1 [25.4]	1 [25.4]	1 [25.4]	1 [25.4]
Face Area sq. ft. [sq. m]	7.07 [0.66]	7.07 [0.66]	7.07 [0.66]	7.07 [0.66]
Rows/FPI [FPcm]	1 / 20 [8]	1 / 20 [8]	1 / 20 [8]	1 / 20 [8]
Refrigerant Control	TX Valves	TX Valves	TX Valves	TX Valves
Drain Connection No./Size in. [mm]	1/0.75 [19.05]	1/0.75 [19.05]	1/0.75 [19.05]	1/0.75 [19.05]
<b>Outdoor Fan - Type</b>	Propeller	Propeller	Propeller	Propeller
No. Used/Diameter in. [mm]	1/24 [609.6]	1/24 [609.6]	1/24 [609.6]	1/24 [609.6]
Drive Type/No. Speeds	Direct/1	Direct/1	Direct/1	Direct/1
CFM [L/s]	4300 [2029]	4300 [2029]	4300 [2029]	4300 [2029]
No. Motors/HP	1 at 1/3 HP	1 at 1/3 HP	1 at 1/3 HP	1 at 1/3 HP
Motor RPM	1050	1050	1050	1050
<b>Indoor Fan - Type</b>	FC Centrifugal	FC Centrifugal	FC Centrifugal	FC Centrifugal
No. Used/Diameter in. [mm]	1/12x9 [305x229]	1/12x9 [305x229]	1/12x9 [305x229]	1/12x9 [305x229]
Drive Type	Direct	Direct	Direct	Direct
No. Speeds	Multiple	Multiple	Multiple	Multiple
No. Motors	1	1	1	1
Motor HP	1	1	1	1
Motor RPM	1050	1050	1050	1050
Motor Frame Size	48	48	48	48
<b>Filter - Type</b>	Field Supplied	Field Supplied	Field Supplied	Field Supplied
Furnished	No	No	No	No
(NO.) Size Recommended in. [mm x mm x mm]	(2)1x16x30 [25x406x762]	(2)1x16x30 [25x406x762]	(2)1x16x30 [25x406x762]	(2)1x16x30 [25x406x762]
<b>Refrigerant Charge Oz. [g]</b>	81 [2296]	81 [2296]	81 [2296]	81 [2296]
<b>Weights</b>				
Net Weight lbs. [kg]	505 [229]	510 [231]	505 [229]	510 [231]
Ship Weight lbs. [kg]	515 [234]	520 [236]	515 [234]	520 [236]

See Page 17 for Notes.

[ ] Designates Metric Conversions

## NOMINAL SIZES 4-5 TONS [14-17.6 kW]

Model RGEXYC Series	048AJV08	048AJV10	060ACV08	060AJV10
<b>Cooling Performance<sup>1</sup></b>				<b>CONTINUED</b> →
Gross Cooling Capacity Btu/h [kW]	48,500 [14.21]	48,500 [14.21]	59,000 [17.29]	59,000 [17.29]
EER2/SEER2 <sup>2</sup>	11.5/15.2	11.5/15.2	11.5/15.2	11.5/15.2
Nominal CFM/AHRI Rated CFM [L/s]	1600/1525 [755/720]	1600/1525 [755/720]	2000/1800 [944/849]	2000/1800 [944/849]
AHRI Net Cooling Capacity Btu/h [kW]	45,500 [13.33]	45,500 [13.33]	57,000 [16.7]	57,000 [16.7]
Net Sensible Capacity Btu/h [kW]	33,300 [9.76]	33,300 [9.76]	39,000 [11.43]	39,000 [11.43]
Net Latent Capacity Btu/h [kW]	14,200 [4.16]	14,200 [4.16]	18,000 [5.27]	18,000 [5.27]
Net System Power kW	3.9	3.9	5.1	5.1
<b>Heating Performance (Gas)<sup>3</sup></b>				
Heating Input Btu/h [kW] (1st Stage/2nd Stage)	56,000/80,000 [16.41/23.44]	70,000/100,000 [20.51/29.3]	56,000/80,000 [16.41/23.44]	70,000/100,000 [20.51/29.3]
Heating Output Btu/h [kW] (1st Stage/2nd Stage)	45,360/64,800 [13.29/18.99]	56,700/81,000 [16.61/23.73]	45,360/64,800 [13.29/18.99]	56,700/81,000 [16.61/23.73]
Temperature Rise Range °F [°C] (1st Stage/2nd Stage)	25-55 [13.9-30.6] / 35-65 [19.4-36.1]	25-55 [13.9-30.6] / 35-65 [19.4-36.1]	25-55 [13.9-30.6] / 35-65 [19.4-36.1]	25-55 [13.9-30.6] / 35-65 [19.4-36.1]
AFUE % <sup>4</sup>	81	81	NA	NA
Steady State Efficiency (%)	NA	NA	81	81
No. Burners	4	5	4	5
No. Stages	2	2	2	2
Gas Connection Pipe Size in. [mm]	0.5 [12.7]	0.5 [12.7]	0.5 [12.7]	0.5 [12.7]
<b>Compressor</b>				
No./Type	1/2/Scroll	1/2/Scroll	1/2/Scroll	1/2/Scroll
<b>Outdoor Sound Rating (dB)<sup>5</sup></b>	81	81	83	83
<b>Outdoor Coil - Fin Type</b>	Louvered	Louvered	Louvered	Louvered
Tube Type	MicroChannel	MicroChannel	MicroChannel	MicroChannel
MicroChannel Depth in. [mm]	1 [25.4]	1 [25.4]	1 [25.4]	1 [25.4]
Face Area sq. ft. [sq. m]	15.98 [1.48]	15.98 [1.48]	15.98 [1.48]	15.98 [1.48]
Rows/FPI [FPcm]	1 / 23 [9]	1 / 23 [9]	1 / 23 [9]	1 / 23 [9]
<b>Indoor Coil - Fin Type</b>	Louvered	Louvered	Louvered	Louvered
Tube Type	MicroChannel	MicroChannel	MicroChannel	MicroChannel
MicroChannel Depth in. [mm]	1 [25.4]	1 [25.4]	1.26 [32]	1.26 [32]
Face Area sq. ft. [sq. m]	7.07 [0.66]	7.07 [0.66]	6.96 [0.65]	6.96 [0.65]
Rows/FPI [FPcm]	1 / 20 [8]	1 / 20 [8]	1 / 20 [8]	1 / 20 [8]
Refrigerant Control	TX Valves	TX Valves	TX Valves	TX Valves
Drain Connection No./Size in. [mm]	1/0.75 [19.05]	1/0.75 [19.05]	1/0.75 [19.05]	1/0.75 [19.05]
<b>Outdoor Fan - Type</b>	Propeller	Propeller	Propeller	Propeller
No. Used/Diameter in. [mm]	1/24 [609.6]	1/24 [609.6]	1/24 [609.6]	1/24 [609.6]
Drive Type/No. Speeds	Direct/1	Direct/1	Direct/1	Direct/1
CFM [L/s]	4300 [2029]	4300 [2029]	4300 [2029]	4300 [2029]
No. Motors/HP	1 at 1/3 HP	1 at 1/3 HP	1 at 1/3 HP	1 at 1/3 HP
Motor RPM	1050	1050	1050	1050
<b>Indoor Fan - Type</b>	FC Centrifugal	FC Centrifugal	FC Centrifugal	FC Centrifugal
No. Used/Diameter in. [mm]	1/12x9 [305x229]	1/12x9 [305x229]	1/12x9 [305x229]	1/12x9 [305x229]
Drive Type	Direct	Direct	Direct	Direct
No. Speeds	Multiple	Multiple	Multiple	Multiple
No. Motors	1	1	1	1
Motor HP	1	1	1	1
Motor RPM	1050	1050	1050	1050
Motor Frame Size	48	48	48	48
<b>Filter - Type</b>	Field Supplied	Field Supplied	Field Supplied	Field Supplied
Furnished	No	No	No	No
(NO.) Size Recommended in. [mm x mm x mm]	(2)1x16x30 [25x406x762]	(2)1x16x30 [25x406x762]	(2)1x16x30 [25x406x762]	(2)1x16x30 [25x406x762]
<b>Refrigerant Charge Oz. [g]</b>	81 [2296]	81 [2296]	89 [2523]	89 [2523]
<b>Weights</b>				
Net Weight lbs. [kg]	505 [229]	510 [231]	510 [231]	515 [234]
Ship Weight lbs. [kg]	515 [234]	520 [236]	520 [236]	525 [238]

See Page 17 for Notes.

[ ] Designates Metric Conversions

## NOMINAL SIZES 4-5 TONS [14-17.6 kW]

Model RGEYC Series	060ADV08	060ADV10	060AJV08	060AJV10
<b>Cooling Performance<sup>1</sup></b>				
Gross Cooling Capacity Btu/h [kW]	59,000 [17.29]	59,000 [17.29]	59,000 [17.29]	59,000 [17.29]
EER2/SEER2 <sup>2</sup>	11.5/15.2	11.5/15.2	11.5/15.2	11.5/15.2
Nominal CFM/AHRI Rated CFM [L/s]	2000/1800 [944/849]	2000/1800 [944/849]	2000/1800 [944/849]	2000/1800 [944/849]
AHRI Net Cooling Capacity Btu/h [kW]	57,000 [16.7]	57,000 [16.7]	57,000 [16.7]	57,000 [16.7]
Net Sensible Capacity Btu/h [kW]	39,000 [11.43]	39,000 [11.43]	39,000 [11.43]	39,000 [11.43]
Net Latent Capacity Btu/h [kW]	18,000 [5.27]	18,000 [5.27]	18,000 [5.27]	18,000 [5.27]
Net System Power kW	5.1	5.1	5.1	5.1
<b>Heating Performance (Gas)<sup>3</sup></b>				
Heating Input Btu/h [kW] (1st Stage/2nd Stage)	56,000/80,000 [16.41/23.44]	70,000/100,000 [20.51/29.3]	56,000/80,000 [16.41/23.44]	70,000/100,000 [20.51/29.3]
Heating Output Btu/h [kW] (1st Stage/2nd Stage)	45,360/64,800 [13.29/18.99]	56,700/81,000 [16.61/23.73]	45,360/64,800 [13.29/18.99]	56,700/81,000 [16.61/23.73]
Temperature Rise Range °F [°C] (1st Stage/2nd Stage)	25-55 [13.9-30.6]/ 35-65 [19.4-36.1]	25-55 [13.9-30.6]/ 35-65 [19.4-36.1]	25-55 [13.9-30.6]/ 35-65 [19.4-36.1]	25-55 [13.9-30.6]/ 35-65 [19.4-36.1]
AFUE % <sup>4</sup>	NA	NA	81	81
Steady State Efficiency (%)	81	81	NA	NA
No. Burners	4	5	4	5
No. Stages	2	2	2	2
Gas Connection Pipe Size in. [mm]	0.5 [12.7]	0.5 [12.7]	0.5 [12.7]	0.5 [12.7]
<b>Compressor</b>				
No./Type	1/2/Scroll	1/2/Scroll	1/2/Scroll	1/2/Scroll
<b>Outdoor Sound Rating (dB)<sup>5</sup></b>				
	83	83	83	83
<b>Outdoor Coil - Fin Type</b>				
Tube Type	Louvered	Louvered	Louvered	Louvered
MicroChannel Depth in. [mm]	MicroChannel	MicroChannel	MicroChannel	MicroChannel
Face Area sq. ft. [sq. m]	1 [25.4]	1 [25.4]	1 [25.4]	1 [25.4]
Rows/FPI [FPcm]	15.98 [1.48]	15.98 [1.48]	15.98 [1.48]	15.98 [1.48]
	1 / 23 [9]	1 / 23 [9]	1 / 23 [9]	1 / 23 [9]
<b>Indoor Coil - Fin Type</b>				
Tube Type	Louvered	Louvered	Louvered	Louvered
MicroChannel Depth in. [mm]	MicroChannel	MicroChannel	MicroChannel	MicroChannel
Face Area sq. ft. [sq. m]	1.26 [32]	1.26 [32]	1.26 [32]	1.26 [32]
Rows/FPI [FPcm]	6.96 [0.65]	6.96 [0.65]	6.96 [0.65]	6.96 [0.65]
	1 / 20 [8]	1 / 20 [8]	1 / 20 [8]	1 / 20 [8]
Refrigerant Control	TX Valves	TX Valves	TX Valves	TX Valves
Drain Connection No./Size in. [mm]	1/0.75 [19.05]	1/0.75 [19.05]	1/0.75 [19.05]	1/0.75 [19.05]
<b>Outdoor Fan - Type</b>				
No. Used/Diameter in. [mm]	Propeller	Propeller	Propeller	Propeller
Drive Type/No. Speeds	1/24 [609.6]	1/24 [609.6]	1/24 [609.6]	1/24 [609.6]
CFM [L/s]	Direct/1	Direct/1	Direct/1	Direct/1
No. Motors/HP	4300 [2029]	4300 [2029]	4300 [2029]	4300 [2029]
Motor RPM	1 at 1/3 HP	1 at 1/3 HP	1 at 1/3 HP	1 at 1/3 HP
	1050	1050	1050	1050
<b>Indoor Fan - Type</b>				
No. Used/Diameter in. [mm]	FC Centrifugal	FC Centrifugal	FC Centrifugal	FC Centrifugal
Drive Type	1/12x9 [305x229]	1/12x9 [305x229]	1/12x9 [305x229]	1/12x9 [305x229]
No. Speeds	Direct	Direct	Direct	Direct
No. Motors	Multiple	Multiple	Multiple	Multiple
Motor HP	1	1	1	1
Motor RPM	1	1	1	1
Motor Frame Size	1050	1050	1050	1050
	48	48	48	48
<b>Filter - Type</b>				
Furnished	Field Supplied	Field Supplied	Field Supplied	Field Supplied
(NO.) Size Recommended in. [mm x mm x mm]	No	No	No	No
	(2)1x16x30 [25x406x762]	(2)1x16x30 [25x406x762]	(2)1x16x30 [25x406x762]	(2)1x16x30 [25x406x762]
<b>Refrigerant Charge Oz. [g]</b>				
	89 [2523]	89 [2523]	89 [2523]	89 [2523]
<b>Weights</b>				
Net Weight lbs. [kg]	510 [231]	515 [234]	515 [234]	515 [234]
Ship Weight lbs. [kg]	520 [236]	525 [238]	525 [238]	525 [238]

See Page 17 for Notes.

[ ] Designates Metric Conversions



## NOTES:

1. Cooling Performance is rated at 95°F ambient, 80°F entering dry bulb, 67°F entering wet bulb. Gross capacity does not include the effect of fan motor heat. AHRI capacity is net and includes the effect of fan motor heat. Units are suitable for operation to  $\pm 20\%$  of nominal CFM. Units are certified in accordance with the Unitary Air Conditioner Equipment certification program, which is based on AHRI Standard 210/240 or 360.
2. EER2 and/or SEER2 are rated at AHRI conditions and in accordance with DOE test procedures.
3. Heating Performance limit settings and rating data were established and approved under laboratory test conditions using American National Standard Institute standards. Ratings shown are for elevations up to 2000 feet. For elevations above 2000 feet, ratings should be reduced at the rate of 4% for each 1000 feet above sea level.
4. AFUE is rated in accordance with DOE test procedures.
5. Outdoor Sound Rating shown is tested in accordance with AHRI Standard 270.

## COOLING PERFORMANCE DATA – RGEAYC024

ENTERING INDOOR AIR @ 80°F [26.7°C] dbE <sup>①</sup>											
wbE		71°F [21.7°C]			67°F [19.4°C]			63°F [17.2°C]			
CFM [L/s]		950 [448]	825 [389]	725 [342]	950 [448]	825 [389]	725 [342]	950 [448]	825 [389]	725 [342]	
DR <sup>①</sup>		.05	.09	.12	.05	.09	.12	.05	.09	.12	
OUTDOOR DRY BULB TEMPERATURE °F [°C]	75 [23.9]	Total kBtu/h [kW] Sens kBtu/h [kW] Power	31.4 [9.2] 18.0 [5.3] 1.6	30.6 [9.0] 16.8 [4.9] 1.6	29.9 [8.8] 15.9 [4.7] 1.6	29.2 [8.6] 21.1 [6.2] 1.6	28.4 [8.3] 19.7 [5.8] 1.6	27.8 [8.1] 18.6 [5.5] 1.6	27.2 [8.0] 24.0 [7.0] 1.6	26.4 [7.7] 22.5 [6.6] 1.5	25.9 [7.6] 21.2 [6.2] 1.5
	80 [26.7]	Total kBtu/h [kW] Sens kBtu/h [kW] Power	30.6 [9.0] 17.5 [5.1] 1.7	29.8 [8.7] 16.3 [4.8] 1.7	29.2 [8.6] 15.4 [4.5] 1.7	28.4 [8.3] 20.6 [6.0] 1.7	27.7 [8.1] 19.2 [5.6] 1.7	27.0 [7.9] 18.1 [5.3] 1.6	26.4 [7.7] 23.5 [6.9] 1.7	25.7 [7.5] 21.9 [6.4] 1.6	25.1 [7.4] 20.7 [6.1] 1.6
	85 [29.4]	Total kBtu/h [kW] Sens kBtu/h [kW] Power	29.8 [8.7] 17.0 [5.0] 1.8	29.0 [8.5] 15.8 [4.6] 1.8	28.4 [8.3] 14.9 [4.4] 1.8	27.6 [8.1] 20.0 [5.9] 1.8	26.9 [7.9] 18.7 [5.5] 1.8	26.3 [7.7] 17.7 [5.2] 1.7	25.6 [7.5] 23.0 [6.7] 1.8	24.9 [7.3] 21.5 [6.3] 1.7	24.3 [7.1] 20.3 [5.9] 1.7
	90 [32.2]	Total kBtu/h [kW] Sens kBtu/h [kW] Power	29.0 [8.5] 16.5 [4.8] 1.9	28.2 [8.3] 15.4 [4.5] 1.9	27.6 [8.1] 14.5 [4.2] 1.9	26.8 [7.9] 19.6 [5.7] 1.9	26.1 [7.6] 18.3 [5.4] 1.9	25.5 [7.5] 17.2 [5.0] 1.8	24.8 [7.3] 22.5 [6.6] 1.9	24.1 [7.1] 21.0 [6.2] 1.8	23.6 [6.9] 19.8 [5.8] 1.8
	95 [35]	Total kBtu/h [kW] Sens kBtu/h [kW] Power	28.2 [8.3] 16.0 [4.7] 2.0	27.4 [8.0] 15.0 [4.4] 2.0	26.8 [7.9] 14.1 [4.1] 1.9	26.0 [7.6] 19.1 [5.6] 2.0	25.3 [7.4] 17.8 [5.2] 2.0	24.7 [7.2] 16.8 [4.9] 1.9	23.9 [7.0] 22 [6.4] 2.0	23.3 [6.8] 20.6 [6.0] 1.9	22.8 [6.7] 19.4 [5.7] 1.9
	100 [37.8]	Total kBtu/h [kW] Sens kBtu/h [kW] Power	27.3 [8.0] 15.6 [4.6] 2.1	26.6 [7.8] 14.5 [4.2] 2.1	26.0 [7.6] 13.7 [4.0] 2.0	25.1 [7.4] 18.7 [5.5] 2.1	24.4 [7.2] 17.4 [5.1] 2.1	23.9 [7.0] 16.4 [4.8] 2.0	23.1 [6.8] 21.6 [6.3] 2.1	22.4 [6.6] 20.2 [5.9] 2.0	22.0 [6.4] 19.0 [5.6] 2.0
	105 [40.6]	Total kBtu/h [kW] Sens kBtu/h [kW] Power	26.4 [7.7] 15.2 [4.5] 2.2	25.7 [7.5] 14.2 [4.2] 2.2	25.2 [7.4] 13.4 [3.9] 2.1	24.2 [7.1] 18.3 [5.4] 2.2	23.6 [6.9] 17.1 [5.0] 2.2	23.1 [6.8] 16.1 [4.7] 2.1	22.2 [6.5] 21.2 [6.2] 2.2	21.6 [6.3] 19.8 [5.8] 2.1	21.1 [6.2] 18.7 [5.5] 2.1
	110 [43.3]	Total kBtu/h [kW] Sens kBtu/h [kW] Power	25.6 [7.5] 14.8 [4.3] 2.3	24.9 [7.3] 13.8 [4.0] 2.3	24.3 [7.1] 13.0 [3.8] 2.2	23.3 [6.8] 17.9 [5.2] 2.3	22.7 [6.7] 16.7 [4.9] 2.3	22.2 [6.5] 15.8 [4.6] 2.2	21.3 [6.2] 20.8 [6.1] 2.3	20.7 [6.1] 19.4 [5.7] 2.2	20.3 [5.9] 18.3 [5.4] 2.2
	115 [46.1]	Total kBtu/h [kW] Sens kBtu/h [kW] Power	24.7 [7.2] 14.4 [4.2] 2.4	24.0 [7.0] 13.5 [4.0] 2.4	23.5 [6.9] 12.7 [3.7] 2.3	22.4 [6.6] 17.5 [5.1] 2.4	21.8 [6.4] 16.4 [4.8] 2.4	21.4 [6.3] 15.4 [4.5] 2.3	20.4 [6.0] 20.4 [6.0] 2.4	19.9 [5.8] 19.1 [5.6] 2.3	19.4 [5.7] 18.0 [5.3] 2.3
	120 [48.9]	Total kBtu/h [kW] Sens kBtu/h [kW] Power	23.7 [6.9] 14.1 [4.1] 2.5	23.1 [6.8] 13.2 [3.9] 2.5	22.6 [6.6] 12.4 [3.6] 2.4	21.5 [6.3] 17.2 [5.0] 2.5	20.9 [6.1] 16.1 [4.7] 2.4	20.5 [6.0] 15.2 [4.5] 2.4	19.5 [5.7] 19.5 [5.7] 2.4	19.0 [5.6] 18.8 [5.5] 2.4	18.5 [5.4] 17.8 [5.2] 2.4
	125 [51.7]	Total kBtu/h [kW] Sens kBtu/h [kW] Power	22.8 [6.7] 13.8 [4.0] 2.6	22.2 [6.5] 12.9 [3.8] 2.6	21.7 [6.4] 12.2 [3.6] 2.5	20.6 [6.0] 16.9 [5.0] 2.6	20.0 [5.9] 15.8 [4.6] 2.5	19.6 [5.7] 14.9 [4.4] 2.5	18.6 [5.5] 18.6 [5.5] 2.5	18.1 [5.3] 18.1 [5.3] 2.5	17.7 [5.2] 17.5 [5.1] 2.5

DR —Depression ratio  
dbE —Entering air dry bulb  
wbE—Entering air wet bulb

Total —Total capacity x 1000 kBtu/h  
Sens —Sensible capacity x 1000 kBtu/h  
Power —kW input

NOTES: <sup>①</sup> When the entering air dry bulb is other than 80°F [27°C], adjust the sensible capacity from the table by adding [1.10 x CFM x (1 – DR) x (dbE – 80)].

[ ] Designates Metric Conversions

## COOLING PERFORMANCE DATA—RGEXYC036

ENTERING INDOOR AIR @ 80°F [26.7°C] dbE ①											
wbE		71°F [21.7°C]			67°F [19.4°C]			63°F [17.2°C]			
CFM [L/s]		1375 [649]	1200 [566]	1075 [507]	1375 [649]	1200 [566]	1075 [507]	1375 [649]	1200 [566]	1075 [507]	
DR ①		.05	.09	.12	.05	.09	.12	.05	.09	.12	
OUTDOOR DRY BULB TEMPERATURE °F [°C]	75 [23.9]	Total kBtu/h [kW] Sens kBtu/h [kW] Power	45.6 [13.4] 26.1 [7.6] 2.5	44.5 [13.0] 24.4 [7.2] 2.5	43.6 [12.8] 23.2 [6.8] 2.4	42.6 [12.5] 30.9 [9.1] 2.5	41.5 [12.2] 28.9 [8.5] 2.4	40.7 [11.9] 27.5 [8.1] 2.4	40.1 [11.8] 36.3 [10.6] 2.4	39.1 [11.5] 34.0 [10.0] 2.4	38.3 [11.2] 32.3 [9.5] 2.4
	80 [26.7]	Total kBtu/h [kW] Sens kBtu/h [kW] Power	44.5 [13.0] 25.6 [7.5] 2.6	43.4 [12.7] 23.9 [7.0] 2.6	42.6 [12.5] 22.8 [6.7] 2.6	41.5 [12.2] 30.4 [8.9] 2.6	40.4 [11.8] 28.5 [8.4] 2.6	39.6 [11.6] 27.1 [7.9] 2.6	39.0 [11.4] 35.8 [10.5] 2.5	38.0 [11.1] 33.5 [9.8] 2.5	37.3 [10.9] 31.9 [9.3] 2.5
	85 [29.4]	Total kBtu/h [kW] Sens kBtu/h [kW] Power	43.4 [12.7] 25.0 [7.3] 2.8	42.3 [12.4] 23.4 [6.9] 2.8	41.5 [12.2] 22.3 [6.5] 2.7	40.3 [11.8] 29.8 [8.7] 2.8	39.3 [11.5] 27.9 [8.2] 2.7	38.5 [11.3] 26.6 [7.8] 2.7	37.8 [11.1] 35.2 [10.3] 2.7	36.9 [10.8] 33.0 [9.7] 2.7	36.2 [10.6] 31.4 [9.2] 2.6
	90 [32.2]	Total kBtu/h [kW] Sens kBtu/h [kW] Power	42.2 [12.4] 24.4 [7.2] 2.9	41.1 [12.0] 22.9 [6.7] 2.9	40.3 [11.8] 21.8 [6.4] 2.9	39.1 [11.5] 29.2 [8.6] 2.9	38.1 [11.2] 27.4 [8.0] 2.9	37.4 [11.0] 26.0 [7.6] 2.8	36.7 [10.8] 34.6 [10.1] 2.8	35.7 [10.5] 32.4 [9.5] 2.8	35.0 [10.3] 30.9 [9.1] 2.8
	95 [35]	Total kBtu/h [kW] Sens kBtu/h [kW] Power	41.0 [12.0] 23.8 [7.0] 3.1	39.9 [11.7] 22.3 [6.5] 3.0	39.1 [11.5] 21.2 [6.2] 3.0	37.9 [11.1] 28.6 [8.4] 3.1	36.9 [10.8] 26.8 [7.9] 3.0	36.2 [10.6] 25.5 [7.5] 3.0	35.4 [10.4] 34.0 [10.0] 3.0	34.5 [10.1] 31.8 [9.3] 2.9	33.9 [9.9] 30.3 [8.9] 2.9
	100 [37.8]	Total kBtu/h [kW] Sens kBtu/h [kW] Power	39.7 [11.6] 23.1 [6.8] 3.2	38.7 [11.3] 21.6 [6.3] 3.2	37.9 [11.1] 20.6 [6.0] 3.2	36.6 [10.7] 27.9 [8.2] 3.2	35.7 [10.5] 26.1 [7.6] 3.2	35.0 [10.3] 24.9 [7.3] 3.1	34.2 [10.0] 33.3 [9.8] 3.1	33.3 [9.8] 31.2 [9.1] 3.1	32.6 [9.6] 29.7 [8.7] 3.1
	105 [40.6]	Total kBtu/h [kW] Sens kBtu/h [kW] Power	38.4 [11.3] 22.4 [6.6] 3.4	37.4 [11.0] 20.9 [6.1] 3.3	36.7 [10.8] 19.9 [5.8] 3.3	35.3 [10.3] 27.2 [8.0] 3.3	34.4 [10.1] 25.5 [7.5] 3.3	33.8 [9.9] 24.2 [7.1] 3.3	32.9 [9.6] 32.6 [9.6] 3.3	32.0 [9.4] 30.5 [8.9] 3.2	31.4 [9.2] 29.0 [8.5] 3.2
	110 [43.3]	Total kBtu/h [kW] Sens kBtu/h [kW] Power	37.0 [10.8] 21.6 [6.3] 3.5	36.1 [10.6] 20.2 [5.9] 3.5	35.4 [10.4] 19.3 [5.7] 3.4	34.0 [10.0] 26.4 [7.7] 3.5	33.1 [9.7] 24.7 [7.2] 3.4	32.5 [9.5] 23.5 [6.9] 3.4	31.5 [9.2] 31.5 [9.2] 3.4	30.7 [9.0] 29.8 [8.7] 3.4	30.1 [8.8] 28.4 [8.3] 3.3
	115 [46.1]	Total kBtu/h [kW] Sens kBtu/h [kW] Power	35.7 [10.5] 20.8 [6.1] 3.7	34.7 [10.2] 19.5 [5.7] 3.6	34.1 [10.0] 18.5 [5.4] 3.6	32.6 [9.6] 25.6 [7.5] 3.6	31.8 [9.3] 24.0 [7.0] 3.6	31.2 [9.1] 22.8 [6.7] 3.6	30.1 [8.8] 30.1 [8.8] 3.6	29.3 [8.6] 29.0 [8.5] 3.5	28.8 [8.4] 27.6 [8.1] 3.5
	120 [48.9]	Total kBtu/h [kW] Sens kBtu/h [kW] Power	34.2 [10.0] 20.0 [5.9] 3.8	33.3 [9.8] 18.7 [5.5] 3.8	32.7 [9.6] 17.8 [5.2] 3.7	31.2 [9.1] 24.8 [7.3] 3.8	30.4 [8.9] 23.2 [6.8] 3.7	29.8 [8.7] 22.1 [6.5] 3.7	28.7 [8.4] 28.7 [8.4] 3.7	28.0 [8.2] 28.0 [8.2] 3.7	27.4 [8.0] 26.9 [7.9] 3.6
	125 [51.7]	Total kBtu/h [kW] Sens kBtu/h [kW] Power	32.8 [9.6] 19.1 [5.6] 3.9	31.9 [9.3] 17.9 [5.2] 3.9	31.3 [9.2] 17.0 [5.0] 3.9	29.7 [8.7] 23.9 [7.0] 3.9	29.0 [8.5] 22.4 [6.6] 3.9	28.4 [8.3] 21.3 [6.2] 3.8	27.2 [8.0] 27.2 [8.0] 3.9	26.5 [7.8] 26.5 [7.8] 3.8	26.0 [7.6] 26.0 [7.6] 3.8

DR —Depression ratio  
dbE —Entering air dry bulb  
wbE —Entering air wet bulb

Total —Total capacity x 1000 kBtu/h  
Sens —Sensible capacity x 1000 kBtu/h  
Power —kW input

NOTES: ① When the entering air dry bulb is other than 80°F [27°C], adjust the sensible capacity from the table by adding  $[1.10 \times \text{CFM} \times (1 - \text{DR}) \times (\text{dbE} - 80)]$ .

[ ] Designates Metric Conversions

## COOLING PERFORMANCE DATA – RGEXYC048A

		ENTERING INDOOR AIR @ 80°F [26.7°C] dbE ①									
wbE		71°F [21.7°C]			67°F [19.4°C]			63°F [17.2°C]			
CFM [L/s]		1950 [920]	1525 [720]	1500 [708]	1950 [920]	1525 [720]	1500 [708]	1950 [920]	1525 [720]	1500 [708]	
DR ①		.05	.09	.12	.05	.09	.12	.05	.09	.12	
OUTDOOR DRY BULB TEMPERATURE °F [°C]	75 [23.9]	Total kBtu/h [kW] Sens kBtu/h [kW] Power	63.1 [18.5] 36.2 [10.6] 3.5	60.1 [17.6] 32.0 [9.4] 3.4	59.9 [17.6] 31.8 [9.3] 3.4	58.8 [17.2] 42.5 [12.5] 3.4	55.9 [16.4] 37.6 [11.0] 3.4	55.8 [16.4] 37.3 [10.9] 3.3	54.7 [16.0] 48.3 [14.2] 3.4	52.1 [15.3] 42.7 [12.5] 3.3	51.9 [15.2] 42.4 [12.4] 3.3
	80 [26.7]	Total kBtu/h [kW] Sens kBtu/h [kW] Power	62.1 [18.2] 36.0 [10.6] 3.6	59.1 [17.3] 31.9 [9.3] 3.5	59.0 [17.3] 31.6 [9.3] 3.5	57.8 [16.9] 42.3 [12.4] 3.6	55.0 [16.1] 37.4 [11.0] 3.5	54.8 [16.1] 37.1 [10.9] 3.5	53.7 [15.7] 48.1 [14.1] 3.6	51.1 [15.0] 42.6 [12.5] 3.5	51.0 [14.9] 42.2 [12.4] 3.5
	85 [29.4]	Total kBtu/h [kW] Sens kBtu/h [kW] Power	61.1 [17.9] 35.7 [10.5] 3.8	58.1 [17.0] 31.6 [9.3] 3.7	58.0 [17.0] 31.4 [9.2] 3.7	56.7 [16.6] 42.0 [12.3] 3.7	54.0 [15.8] 37.2 [10.9] 3.7	53.8 [15.8] 36.9 [10.8] 3.6	52.7 [15.4] 47.8 [14.0] 3.7	50.1 [14.7] 42.3 [12.4] 3.6	50.0 [14.7] 42.0 [12.3] 3.6
	90 [32.2]	Total kBtu/h [kW] Sens kBtu/h [kW] Power	59.9 [17.6] 35.3 [10.3] 3.9	57.1 [16.7] 31.2 [9.1] 3.8	56.9 [16.7] 31.0 [9.1] 3.8	55.6 [16.3] 41.6 [12.2] 3.9	52.9 [15.5] 36.8 [10.8] 3.8	52.7 [15.4] 36.5 [10.7] 3.8	51.5 [15.1] 47.4 [13.9] 3.9	49.0 [14.4] 41.9 [12.3] 3.8	48.9 [14.3] 41.6 [12.2] 3.8
	95 [35]	Total kBtu/h [kW] Sens kBtu/h [kW] Power	58.7 [17.2] 34.8 [10.2] 4.1	55.9 [16.4] 30.8 [9.0] 4.0	55.7 [16.3] 30.5 [8.9] 4.0	54.4 [15.9] 41.1 [12.0] 4.1	51.7 [15.2] 36.4 [10.7] 4.0	51.6 [15.1] 36.1 [10.6] 4.0	50.3 [14.7] 46.9 [13.7] 4.1	47.9 [14.0] 41.5 [12.2] 4.0	47.8 [14.0] 41.2 [12.1] 4.0
	100 [37.8]	Total kBtu/h [kW] Sens kBtu/h [kW] Power	57.5 [16.9] 34.2 [10.0] 4.3	54.7 [16.0] 30.2 [8.9] 4.2	54.6 [16.0] 30.0 [8.8] 4.2	53.1 [15.6] 40.5 [11.9] 4.3	50.5 [14.8] 35.8 [10.5] 4.2	50.4 [14.8] 35.5 [10.4] 4.2	49.1 [14.4] 46.3 [13.6] 4.3	46.7 [13.7] 40.9 [12.0] 4.1	46.6 [13.7] 40.6 [11.9] 4.1
	105 [40.6]	Total kBtu/h [kW] Sens kBtu/h [kW] Power	56.2 [16.5] 33.4 [9.8] 4.5	53.5 [15.7] 29.6 [8.7] 4.4	53.3 [15.6] 29.4 [8.6] 4.4	51.8 [15.2] 39.7 [11.6] 4.5	49.3 [14.4] 35.1 [10.3] 4.4	49.1 [14.4] 34.9 [10.2] 4.4	47.8 [14.0] 45.5 [13.3] 4.5	45.5 [13.3] 40.3 [11.8] 4.3	45.3 [13.3] 40.0 [11.7] 4.3
	110 [43.3]	Total kBtu/h [kW] Sens kBtu/h [kW] Power	54.8 [16.1] 32.6 [9.6] 4.7	52.1 [15.3] 28.8 [8.4] 4.6	52.0 [15.2] 28.6 [8.4] 4.6	50.4 [14.8] 38.9 [11.4] 4.7	48.0 [14.1] 34.4 [10.1] 4.6	47.8 [14.0] 34.1 [10.0] 4.6	46.4 [13.6] 44.7 [13.1] 4.7	44.1 [12.9] 39.5 [11.6] 4.6	44.0 [12.9] 39.2 [11.5] 4.5
	115 [46.1]	Total kBtu/h [kW] Sens kBtu/h [kW] Power	53.3 [15.6] 31.6 [9.3] 5.0	50.8 [14.9] 28.0 [8.2] 4.8	50.6 [14.8] 27.8v [8.1] 4.8	48.9 [14.3] 37.9 [11.1] 4.9	46.6 [13.7] 33.6 [9.8] 4.8	46.4 [13.6] 33.3 [9.8] 4.8	44.9 [13.2] 43.7 [12.8] 4.9	42.8 [12.5] 38.7 [11.3] 4.8	42.6 [12.5] 38.4 [11.3] 4.8
	120 [48.9]	Total kBtu/h [kW] Sens kBtu/h [kW] Power	51.8 [15.2] 30.6 [9.0] 5.2	49.3 [14.4] 27.0 [7.9] 5.1	49.2 [14.4] 26.8 [7.9] 5.1	47.4 [13.9] 36.9 [10.8] 5.2	45.1 [13.2] 32.6 [9.6] 5.0	45.0 [13.2] 32.4 [9.5] 5.0	43.4 [12.7] 42.7 [12.5] 5.1	41.3 [12.1] 37.7 [11] 5.0	41.2 [12.1] 37.5 [11] 5.0
125 [51.7]	Total kBtu/h [kW] Sens kBtu/h [kW] Power	50.2 [14.7] 29.4 [8.6] 5.4	47.8 [14.0] 26.0 [7.6] 5.3	47.7 [14.0] 25.8 [7.6] 5.3	45.9 [13.5] 35.7 [10.5] 5.4	43.6 [12.8] 31.6 [9.3] 5.3	43.5 [12.7] 31.3 [9.2] 5.3	41.8 [12.3] 41.5 [12.2] 5.4	39.8 [11.7] 36.7 [10.8] 5.3	39.7 [11.6] 36.4 [10.7] 5.2	

DR —Depression ratio  
dbE —Entering air dry bulb  
wbE—Entering air wet bulb

Total —Total capacity x 1000 kBtu/h  
Sens —Sensible capacity x 1000 kBtu/h  
Power —kW input

NOTES: ① When the entering air dry bulb is other than 80°F [27°C], adjust the sensible capacity from the table by adding  $[1.10 \times \text{CFM} \times (1 - \text{DR}) \times (\text{dbE} - 80)]$ .

[ ] Designates Metric Conversions

# COOLING PERFORMANCE DATA—RGEXYC060A

		ENTERING INDOOR AIR @ 80°F [26.7°C] dbE ①									
wbE		71°F [21.7°C]			67°F [19.4°C]			63°F [17.2°C]			
CFM [L/s]		2300 [1085]	1825 [861]	1775 [838]	2300 [1085]	1825 [861]	1775 [838]	2300 [1085]	1825 [861]	1775 [838]	
DR ①		.05	.09	.12	.05	.09	.12	.05	.09	.12	
OUTDOOR DRY BULB TEMPERATURE °F [°C]	75 [23.9]	Total kBtu/h [kW] Sens kBtu/h [kW] Power	74.8 [21.9] 43.1 [12.6] 4.3	71.4 [20.9] 38.4 [11.3] 4.2	71.0 [20.8] 37.9 [11.1] 4.2	70.0 [20.5] 50.8 [14.9] 4.3	66.8 [19.6] 45.3 [13.3] 4.2	66.5 [19.5] 44.7 [13.1] 4.2	66.2 [19.4] 58.6 [17.2] 4.2	63.2 [18.5] 52.3 [15.3] 4.1	62.9 [18.4] 51.6 [15.1] 4.0
	80 [26.7]	Total kBtu/h [kW] Sens kBtu/h [kW] Power	73.4 [21.5] 42.6 [12.5] 4.6	70.1 [20.5] 38.0 [11.1] 4.4	69.7 [20.4] 37.5 [11.0] 4.4	68.6 [20.1] 50.3 [14.7] 4.5	65.5 [19.2] 44.9 [13.2] 4.4	65.2 [19.1] 44.3 [13.0] 4.4	64.8 [19.0] 58.1 [17.0] 4.4	61.9 [18.1] 51.8 [15.2] 4.3	61.6 [18.1] 51.2 [15.0] 4.3
	85 [29.4]	Total kBtu/h [kW] Sens kBtu/h [kW] Power	72.0 [21.1] 42.0 [12.3] 4.8	68.7 [20.1] 37.5 [11.0] 4.7	68.4 [20.0] 37.0 [10.8] 4.7	67.2 [19.7] 49.8 [14.6] 4.7	64.2 [18.8] 44.4 [13.0] 4.6	63.8 [18.7] 43.8 [12.8] 4.6	63.4 [18.6] 57.6 [16.9] 4.6	60.5 [17.7] 51.3 [15.0] 4.5	60.2 [17.6] 50.7 [14.9] 4.5
	90 [32.2]	Total kBtu/h [kW] Sens kBtu/h [kW] Power	70.5 [20.7] 41.4 [12.1] 5.0	67.3 [19.7] 36.9 [10.8] 4.9	66.9 [19.6] 36.4 [10.7] 4.9	65.7 [19.3] 49.2 [14.4] 5.0	62.7 [18.4] 43.8 [12.8] 4.9	62.4 [18.3] 43.3 [12.7] 4.8	61.9 [18.1] 56.9 [16.7] 4.8	59.1 [17.3] 50.8 [14.9] 4.7	58.8 [17.2] 50.1 [14.7] 4.7
	95 [35]	Total kBtu/h [kW] Sens kBtu/h [kW] Power	68.9 [20.2] 40.7 [11.9] 5.2	65.8 [19.3] 36.3 [10.6] 5.1	65.5 [19.2] 35.8 [10.5] 5.1	64.1 [18.8] 48.5 [14.2] 5.2	61.2 [17.9] 43.2 [12.7] 5.1	60.9 [17.8] 42.7 [12.5] 5.1	60.3 [17.7] 56.3 [16.5] 5.1	57.6 [16.9] 50.2 [14.7] 5.0	57.3 [16.8] 49.5 [14.5] 5.0
	100 [37.8]	Total kBtu/h [kW] Sens kBtu/h [kW] Power	67.3 [19.7] 40.0 [11.7] 5.5	64.2 [18.8] 35.6 [10.4] 5.4	63.9 [18.7] 35.2 [10.3] 5.3	62.5 [18.3] 47.7 [14.0] 5.4	59.7 [17.5] 42.6 [12.5] 5.3	59.4 [17.4] 42.0 [12.3] 5.3	58.7 [17.2] 55.5 [16.3] 5.3	56.0 [16.4] 49.5 [14.5] 5.2	55.7 [16.3] 48.9 [14.3] 5.2
	105 [40.6]	Total kBtu/h [kW] Sens kBtu/h [kW] Power	65.6 [19.2] 39.1 [11.5] 5.7	62.6 [18.3] 34.9 [10.2] 5.6	62.3 [18.3] 34.5 [10.1] 5.6	60.8 [17.8] 46.9 [13.7] 5.7	58.0 [17.0] 41.8 [12.3] 5.5	57.7 [16.9] 41.3 [12.1] 5.5	57.0 [16.7] 54.7 [16.0] 5.5	54.4 [15.9] 48.8 [14.3] 5.4	54.1 [15.9] 48.2 [14.1] 5.4
	110 [43.3]	Total kBtu/h [kW] Sens kBtu/h [kW] Power	63.8 [18.7] 38.3 [11.2] 5.9	60.9 [17.8] 34.1 [10.0] 5.8	60.6 [17.8] 33.7 [9.9] 5.8	59.0 [17.3] 46.0 [13.5] 5.9	56.3 [16.5] 41.0 [12.0] 5.8	56.1 [16.4] 40.5 [11.9] 5.7	55.2 [16.2] 53.8 [15.8] 5.8	52.7 [15.4] 48.0 [14.1] 5.7	52.4 [15.4] 47.4 [13.9] 5.6
	115 [46.1]	Total kBtu/h [kW] Sens kBtu/h [kW] Power	61.9 [18.1] 37.3 [10.9] 6.2	59.1 [17.3] 33.3 [9.8] 6.0	58.8 [17.2] 32.9 [9.6] 6.0	57.2 [16.8] 45.1 [13.2] 6.1	54.6 [16.0] 40.2 [11.8] 6.0	54.3 [15.9] 39.7 [11.6] 6.0	53.3 [15.6] 52.9 [15.5] 6.0	50.9 [14.9] 47.1 [13.8] 5.9	50.7 [14.9] 46.5 [13.6] 5.9
	120 [48.9]	Total kBtu/h [kW] Sens kBtu/h [kW] Power	60.0 [17.6] 36.3 [10.6] 6.4	57.3 [16.8] 32.4 [9.5] 6.3	57.0 [16.7] 32.0 [9.4] 6.3	55.2 [16.2] 44.1 [12.9] 6.4	52.7 [15.4] 39.3 [11.5] 6.2	52.5 [15.4] 38.8 [11.4] 6.2	51.4 [15.1] 51.4 [15.1] 6.2	49.1 [14.4] 46.2 [13.5] 6.1	48.8 [14.3] 45.7 [13.4] 6.1
	125 [51.7]	Total kBtu/h [kW] Sens kBtu/h [kW] Power	58.0 [17.0] 35.2 [10.3] 6.6	55.4 [16.2] 31.4 [9.2] 6.5	55.1 [16.1] 31.0 [9.1] 6.5	53.3 [15.6] 43.0 [12.6] 6.6	50.8 [14.9] 38.3 [11.2] 6.4	50.6 [14.8] 37.8 [11.1] 6.4	49.4 [14.5] 49.4 [14.5] 6.5	47.2 [13.8] 45.3 [13.3] 6.3	47.0 [13.8] 44.7 [13.1] 6.3

DR —Depression ratio  
dbE —Entering air dry bulb  
wbE—Entering air wet bulb

Total —Total capacity x 1000 kBtu/h  
Sens —Sensible capacity x 1000 kBtu/h  
Power —kW input

NOTES: ① When the entering air dry bulb is other than 80°F [27°C], adjust the sensible capacity from the table by adding  $[1.10 \times \text{CFM} \times (1 - \text{DR}) \times (\text{dbE} - 80)]$ .

[ ] Designates Metric Conversions

## AIRFLOW PERFORMANCE DATA

<b>RGEAYC024 AIRFLOW TARGETS</b>		
<b>THERMOSTAT CALL</b>	<b>NOMINAL CFM</b>	<b>MANUFACTURER RECOMMENDED COOLING AIRFLOW (MIN/MAX)</b>
High Cooling	800	700 / 900
Low Cooling	600	
60k High Heating	1025	
60K Low Heat	930	
Fan	400	

<b>RGEAYC036 AIRFLOW TARGETS</b>		
<b>THERMOSTAT CALL</b>	<b>NOMINAL CFM</b>	<b>MANUFACTURER RECOMMENDED COOLING AIRFLOW (MIN/MAX)</b>
High Cooling	1200	1050 / 1350
Low Cooling	800	
100k High Heat	1540	
100K Low Heat	1280	
80k High Heat	1465	
80K Low Heat	1300	
60k High Heat	1224	
60K Low Heat	1120	
Fan	600	

<b>RGEAYC048 AIRFLOW TARGETS</b>		
<b>THERMOSTAT CALL</b>	<b>NOMINAL CFM</b>	<b>MANUFACTURER RECOMMENDED COOLING AIRFLOW (MIN/MAX)</b>
High Cooling	1525	1400 / 1800
Low Cooling	1000	
100k High Heat	1465	
100K Low Heat	1250	
80k High Heat	1066	
80K Low Heat	889	
Fan	750	

<b>RGEAYC060 AIRFLOW TARGETS</b>		
<b>THERMOSTAT CALL</b>	<b>NOMINAL CFM</b>	<b>MANUFACTURER RECOMMENDED COOLING AIRFLOW (MIN/MAX)</b>
High Cooling	1800	1750 / 2250
Low Cooling	1200	
100k High Heat	1600	
100K Low Heat	1296	
80k High Heat	1240	
80K Low Heat	1065	
Fan	900	

**NOTES:** Max airflow could be either heating or cooling speed, depending on tonnage. see airflow table for duct sizing.

ELECTRICAL DATA - RGEAYC SERIES									
		024ACV06	024AJV06	036ACV06	036ACV08	036ACV10	036ADV06	036ADV08	036ADV10
Unit Information	Unit Operating Voltage Range	187-253	187-253	187-253	187-253	187-253	414-506	414-506	414-506
	Volts	208/230	208/230	208/230	208/230	208/230	460	460	460
	Phase	3	1	3	3	3	3	3	3
	Hz	60	60	60	60	60	60	60	60
	Minimum Circuit Ampacity	18	24	21	21	21	11	11	11
	Minimum Overcurrent Protection Device Size	20	35	25	25	25	15	15	15
	Maximum Overcurrent Protection Device Size	25	35	30	30	30	15	15	15
Compressor Motor	No.	1	1	1	1	1	1	1	1
	Volts	208/230	208/230	208/230	208/230	208/230	460	460	460
	Phase	3	1	3	3	3	3	3	3
	RPM	3500	3500	3500	3500	3500	3500	3500	3500
	Amps (RLA), Comp. 1	6.8	11.9	9.4	9.4	9.4	5.0	5.0	5.0
	Amps (LRA), Comp. 1	70.0	65.0	82.0	82.0	82.0	44.3	44.3	44.3
	HP, Compressor 2	N/A	N/A	N/A	N/A	N/A	N/A	N/A	N/A
	Amps (RLA), Comp. 2	N/A	N/A	N/A	N/A	N/A	N/A	N/A	N/A
Amps (LRA), Comp. 2	N/A	N/A	N/A	N/A	N/A	N/A	N/A	N/A	
Condenser Motor	No.	1	1	1	1	1	1	1	1
	Volts	208/230	208/230	208/230	208/230	208/230	460	460	460
	Phase	1	1	1	1	1	1	1	1
	HP	1/6	1/6	1/3	1/3	1/3	1/3	1/3	1/3
	Amps (FLA, each)	0.6	0.6	1.5	1.5	1.5	0.8	0.8	0.8
	Amps (LRA, each)	1.5	1.5	3.0	3.0	3.0	1.6	1.6	1.6
Evaporator Fan	No.	1	1	1	1	1	1	1	1
	Volts	208/230	208/230	208/230	208/230	208/230	460	460	460
	Phase	1	1	1	1	1	1	1	1
	HP	1	1	1	1	1	1	1	1
	Amps (FLA, each)	7.6	7.6	7.6	7.6	7.6	3.5	3.5	3.5
	Amps (LRA, each)	N/A	N/A	N/A	N/A	N/A	N/A	N/A	N/A

**ELECTRICAL DATA - RGEAYC SERIES**

		<b>036AJV06</b>	<b>036AJV08</b>	<b>036AJV10</b>
<b>Unit Information</b>	Unit Operating Voltage Range	187-253	187-253	187-253
	Volts	208/230	208/230	208/230
	Phase	1	1	1
	Hz	60	60	60
	Minimum Circuit Ampacity	28	28	28
	Minimum Overcurrent Protection Device Size	35	35	35
	Maximum Overcurrent Protection Device Size	40	40	40
<b>Compressor Motor</b>	No.	1	1	1
	Volts	208/230	208/230	208/230
	Phase	1	1	1
	RPM	3500	3500	3500
	Amps (RLA), Comp. 1	14.9	14.9	14.9
	Amps (LRA), Comp. 1	90.0	90.0	90.0
	HP, Compressor 2	N/A	N/A	N/A
	Amps (RLA), Comp. 2	N/A	N/A	N/A
	Amps (LRA), Comp. 2	N/A	N/A	N/A
<b>Condenser Motor</b>	No.	1	1	1
	Volts	208/230	208/230	208/230
	Phase	1	1	1
	HP	1/3	1/3	1/3
	Amps (FLA, each)	1.5	1.5	1.5
	Amps (LRA, each)	3	3	3
<b>Evaporator Fan</b>	No.	1	1	1
	Volts	208/230	208/230	208/230
	Phase	1	1	1
	HP	1	1	1
	Amps (FLA, each)	7.6	7.6	7.6
	Amps (LRA, each)	N/A	N/A	N/A



ELECTRICAL DATA - RGEXYC SERIES										
		048ACV08	048ACV10	048ADV08	048ADV10	048AJV08	048AJV10	060ACV08	060ACV10	060ADV08
Unit Information	Unit Operating Voltage Range	187-253	187-253	414-506	414-506	187-253	187-253	187-253	187-253	414-506
	Volts	208/230	208/230	460	460	208/230	208/230	208/230	208/230	460
	Phase	3	3	3	3	1	1	3	3	3
	Hz	60	60	60	60	60	60	60	60	60
	Minimum Circuit Ampacity	25	25	14	14	35	35	27	27	14
	Minimum Overcurrent Protection Device Size	30	30	20	20	40	40	35	35	20
	Maximum Overcurrent Protection Device Size	35	35	20	20	50	50	40	40	20
Compressor Motor	No.	1	1	1	1	1	1	1	1	1
	Volts	208/230	208/230	460	460	208/230	208/230	208/230	208/230	460
	Phase	3	3	3	3	1	1	3	3	3
	RPM	3500	3500	3500	3500	3500	3500	3500	3500	3500
	Amps (RLA), Comp. 1	12.1	12.1	7.1	7.1	20.1	20.1	13.8	13.8	6.9
	Amps (LRA), Comp. 1	123	123	60	60	141	141	150	150	60
	HP, Compressor 2	N/A	N/A	N/A	N/A	N/A	N/A	N/A	N/A	N/A
	Amps (RLA), Comp. 2	N/A	N/A	N/A	N/A	N/A	N/A	N/A	N/A	N/A
	Amps (LRA), Comp. 2	N/A	N/A	N/A	N/A	N/A	N/A	N/A	N/A	N/A
Condenser Motor	No.	1	1	1	1	1	1	1	1	1
	Volts	208/230	208/230	460	460	208/230	208/230	208/230	208/230	460
	Phase	1	1	1	1	1	1	1	1	1
	HP	1/3	1/3	1/3	1/3	1/3	1/3	1/3	1/3	1/3
	Amps (FLA, each)	2	2	1	1	2	2	2	2	1
	Amps (LRA, each)	3.9	3.9	2.2	2.2	3.9	3.9	3.9	3.9	2.2
Evaporator Fan	No.	1	1	1	1	1	1	1	1	1
	Volts	208/230	208/230	460	460	208/230	208/230	208/230	208/230	460
	Phase	1	1	1	1	1	1	1	1	1
	HP	1	1	1	1	1	1	1	1	1
	Amps (FLA, each)	7.6	7.6	3.5	3.5	7.6	7.6	7.6	7.6	3.5
	Amps (LRA, each)	N/A	N/A	N/A	N/A	N/A	N/A	N/A	N/A	N/A

<b>ELECTRICAL DATA - RGEXYC SERIES</b>				
		<b>060ADV10</b>	<b>060AJV08</b>	<b>060AJV10</b>
<b>Unit Information</b>	Unit Operating Voltage Range	414-506	187-253	187-253
	Volts	460	208/230	208/230
	Phase	3	1	1
	Hz	60	60	60
	Minimum Circuit Ampacity	14	42	42
	Minimum Overcurrent Protection Device Size	20	50	50
	Maximum Overcurrent Protection Device Size	20	60	60
<b>Compressor Motor</b>	No.	1	1	1
	Volts	460	208/230	208/230
	Phase	3	1	1
	RPM	3500	3500	3500
	Amps (RLA), Comp. 1	6.9	25.2	25.2
	Amps (LRA), Comp. 1	60	147.3	147.3
	HP, Compressor 2	N/A	N/A	N/A
	Amps (RLA), Comp. 2	N/A	N/A	N/A
	Amps (LRA), Comp. 2	N/A	N/A	N/A
<b>Condenser Motor</b>	No.	1	1	1
	Volts	460	208/230	208/230
	Phase	1	1	1
	HP	1/3	1/3	1/3
	Amps (FLA, each)	1	2	2
	Amps (LRA, each)	2.2	3.9	3.9
<b>Evaporator Fan</b>	No.	1	1	1
	Volts	460	208/230	208/230
	Phase	1	1	1
	HP	1	1	1
	Amps (FLA, each)	3.5	7.6	7.6
	Amps (LRA, each)	N/A	N/A	N/A

## ACCESSORY EQUIPMENT

Accessory Description	Model Application	Accessory Model No.
Roofcurb	RGEA	RXSG-AAA08 (8" [203 mm] Height)
		RXSG-AAA14 (14" [356 mm] Height)
	RGEX	RXSG-AXA14 (14" [356 mm] Height)
		RXSG-AXA24 (24" [610 mm] Height)
Curb Adapter ("A" footprint to "X" footprint)	RGEX	RXRX-DXCAE
Duct Adapter Square to Round Transition (Sideflow)	RGE(A/X)	AXMC-BA01
Supply & Return Diffusers (Downflow)	RGE(A/X)	RXRN-BD15
Rectangular to Round Transition (Downflow)	RGE(A/X)	RXMC-CA02 (16" [406 mm] Ducts)
		RXMC-CA03 (18" [457 mm] Ducts)
Economizers (Convertible)	RGEA	AXRD-01RACAM3
	RGEX	RXRE-11RXCAM3
Dual Enthalpy Kit	RGEA	RXRX-AV04
	RGEX	PD555460
Fresh Air Damper	RGEA	AXRF-FAA1 (Fixed-35%)
		AXRF-FAB1 (Motorized-35%)
	RGEX	RXRF-FAA2 (Fixed-35%)
		RXRF-FAB2 (Motorized-35%)
LP Conversion Kits <sup>1</sup>	RGEA RGEX (Standard units)	RXGJ-FP28 (2-stage gas valve)
	RGEX (NOx units)	RXGJ-FP48
Filter Kit	RGEA	RXRY-B01
	RGEX	RXRY-B02
Split Door Design Kit	RGEX	RXRX-SDX01
Low Ambient Control	RGE(A/X)	RXPZ-G01
Phase Monitor Kit	3ph-RGE(A/X)	RXRX-PM3A01

<sup>1</sup>If a particular unit is to be converted to operate on LP (propane) for elevations above 2000 ft. [609.6 m] in Canada, the existing Natural Gas to LP Conversion Kits for the subject models already contain the necessary orifices and instructions to de-rate the input for 2000-4500 ft. [609.6-1371.6 m] Canadian applications.

**NOTE:** High and low pressure switches are standard for RGEA/XYC Models.

[ ] Designates Metric Conversions

## COMMON SUPPLY/RETURN CONCENTRIC AIR DIFFUSER

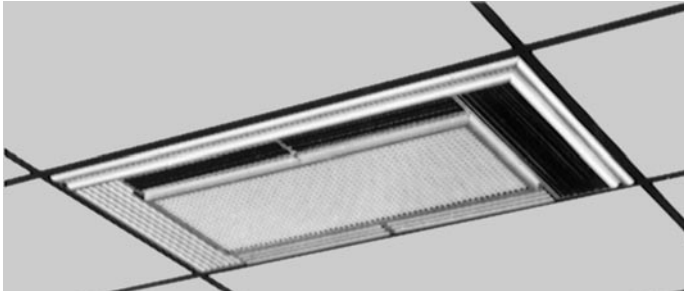

## SUPPLY/RETURN DIFFUSER

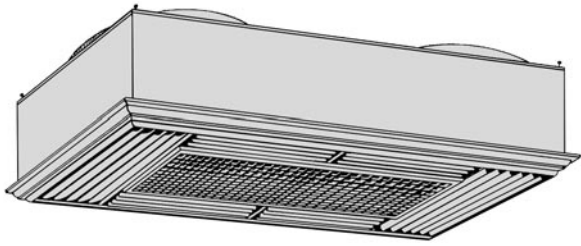

Designed to convert a side by side or an over and under arrangement into a concentric distribution of air. The diffuser is flush mounted, completely insulated, assembled, and internally baffled to provide four way supply air distribution with a center return. To make the assembly complete and ready to fit into a 2' [0.61 m] x 4' [1.22 m] suspended ceiling grid, the diffuser includes adjustable supply louvers, hanging rings, anti-sweat gasket, and round flanges for use with flexible ducts.

Model No. RXRN-	Diameter Inches [mm]	Shipping Wt. Lbs. [kg]	Dimension A Inches [mm]
BD15	16 [406]	90 [40.82]	20 1/2 [521]

[ ] Designates Metric Conversions

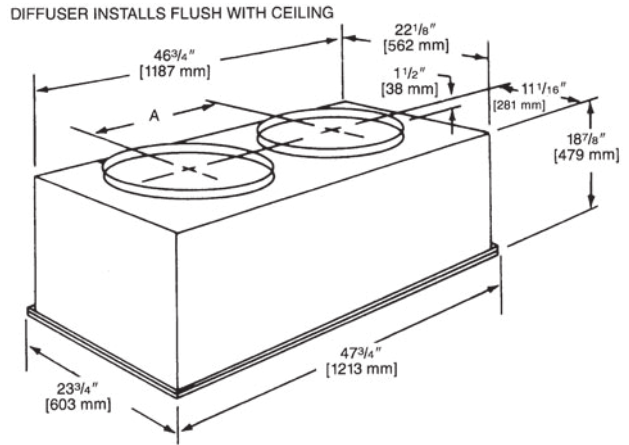

**NOTE:** The location of the combination supply and return diffuser should not exceed 10 feet [3.05 m] above the floor level for units @ 1000 CFM [472 L/s] or less and 12 [3.66 m] to 14 feet [4.27 m] above the floor level for units with CFM greater than 1000 [472 L/s]. If the diffuser is installed with a greater distance than recommended above, the supply air may become stratified above the required comfort area causing uncomfortable conditions.

## AIRFLOW/PRESSURE DROP INFORMATION (INCHES W.C. [kPa])

Accessory	Approximate CFM [L/s]-Supply Air			
	1300 [614]	1575 [743]	1800 [850]	2200 [1038]
Plenum & Supply/Return Duct	.07 [.017]	.10 [.024]	.12 [.030]	.17 [.042]
Diffuser	.09 [.022]	.13 [.032]	.16 [.040]	.24 [.060]
Economizer	.06 [.015]	.09 [.022]	.11 [.027]	.17 [.042]

## SUPPLY AIR/PERFORMANCE

Diffuser Airflow CFM [L/s]	Range of Throw Ft. [m]
800 [378]-1200 [566]	14 [4.27]-16 [4.88]
1600 [755]-2000 [944]	18 [5.49]-28 [8.53]

## DUCT ADAPTERS RECTANGULAR TO ROUND TRANSITIONS (DOWNFLOW)

**RXMC-CA02**

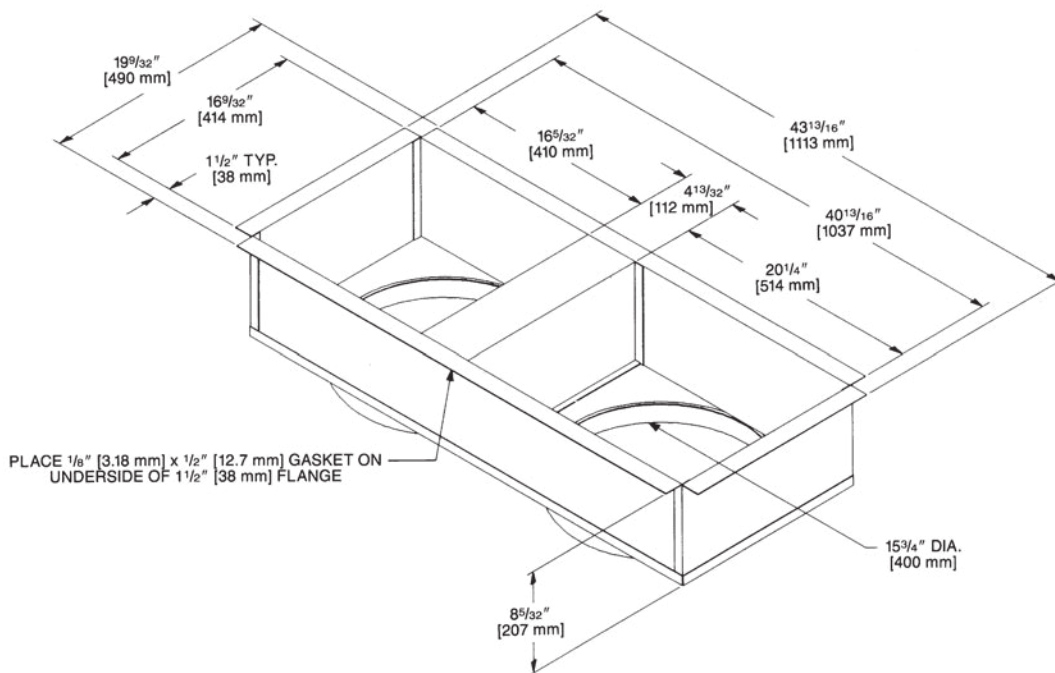

**RXMC-CA03**

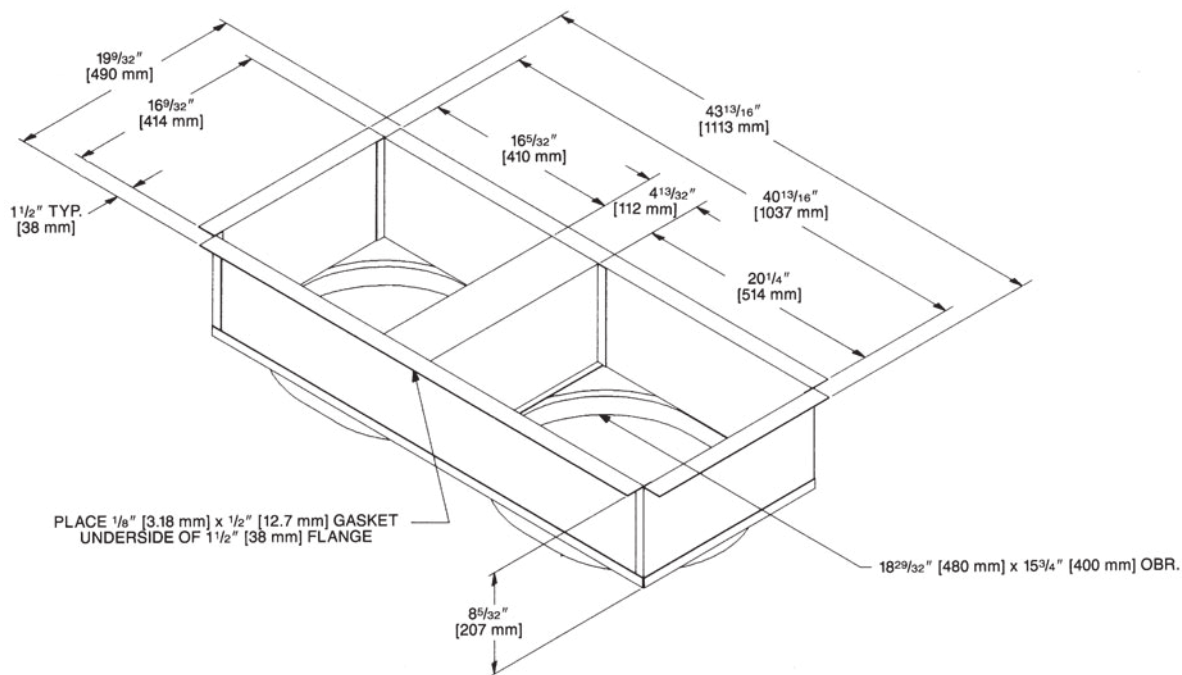

[ ] Designates Metric Conversions

## DUCT ADAPTER SIDEFLOW SQUARE TO ROUND TRANSITION AXMC-BA01

Adapts the side rectangular supply and return openings to 14" [356 mm] diameter round openings. Adapters provided with same finish as unit and also provided with thermal insulation.

[ ] Designates Metric Conversions

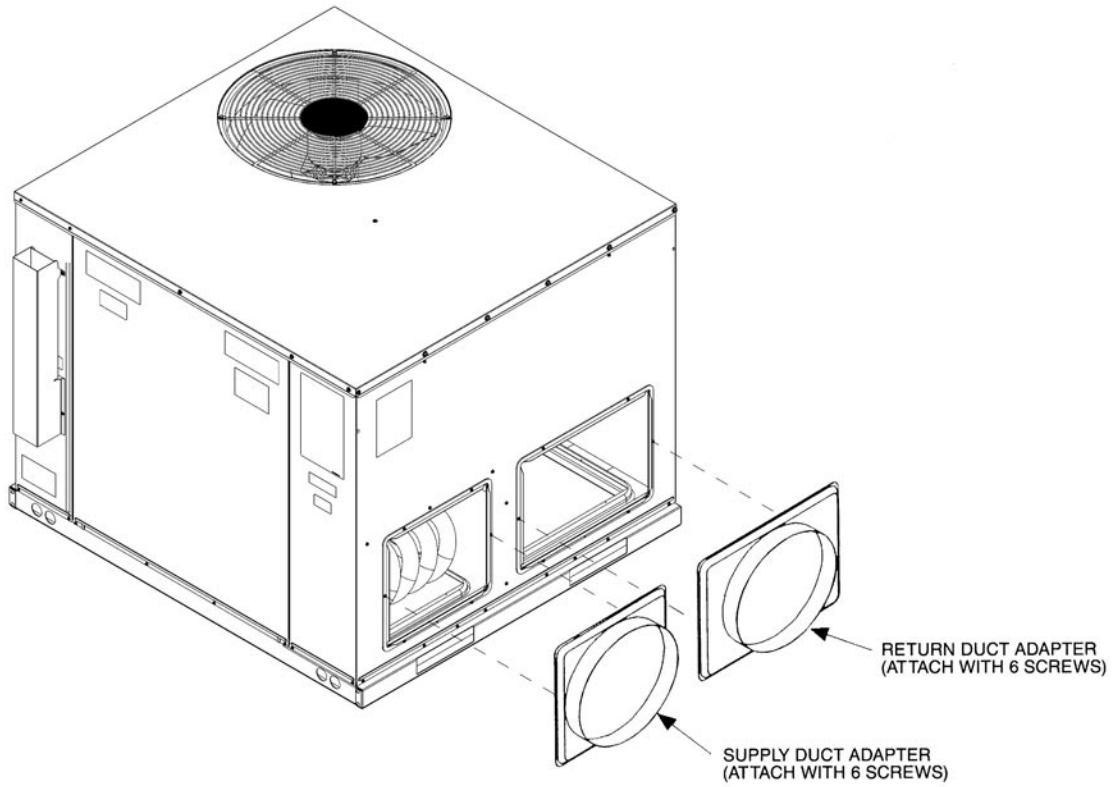

## ROOFCURB (Full Perimeter)

### RXSG-AAA08, RXSG-AAA14 – for the "A" cabinet

Hinged corners make for fast, easy set-up

#### RXSG-AAA08 (8" [203 mm] High)

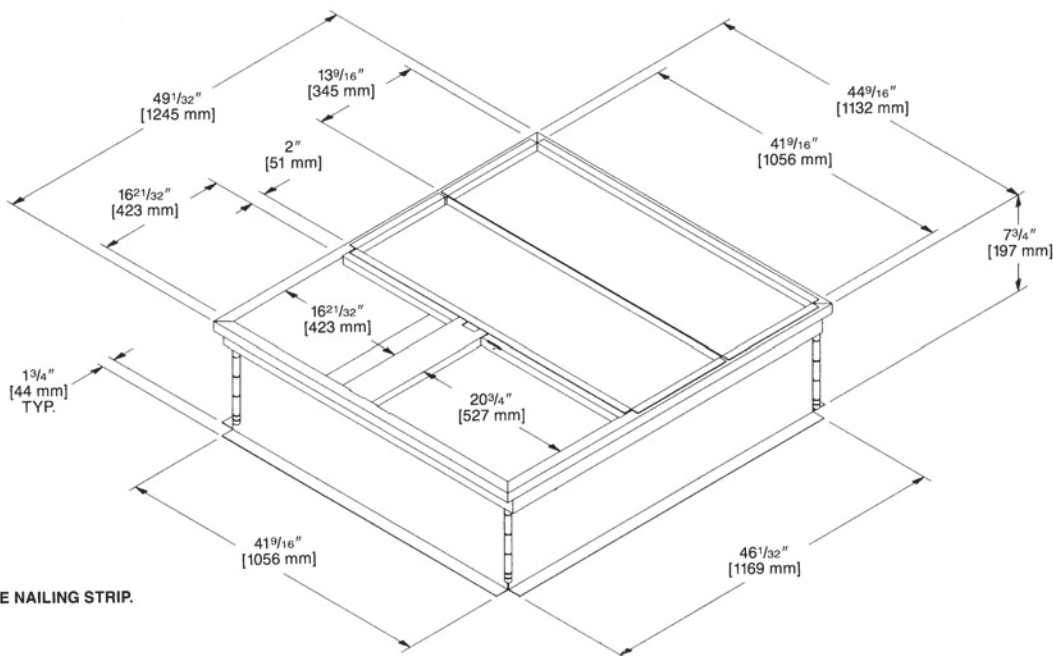

NOTE: PERIMETER OF ROOFCURB IS SUPPLIED WITH A NOMINAL 1" [25.4 mm] x 4" [102 mm] PINE NAILING STRIP.

#### RXSG-AAA14 (14" [356 mm] High)

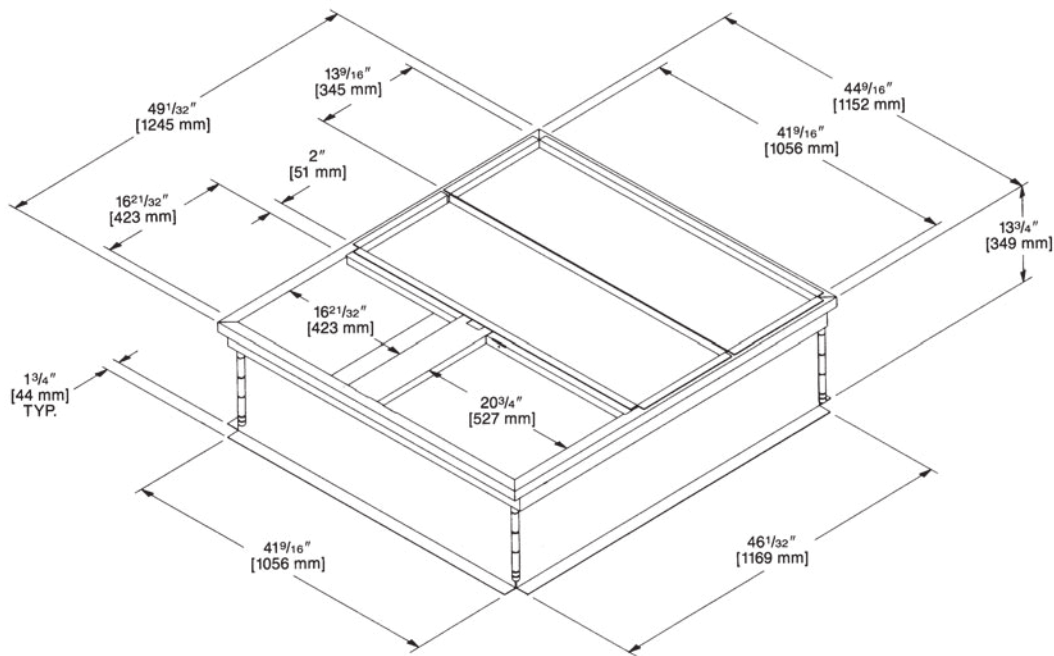

NOTE: PERIMETER OF ROOFCURB IS SUPPLIED WITH A NORMAL 1" [25.4 mm] x 4" [102 mm] PINE NAILING STRIP.

[ ] Designates Metric Conversions

## ROOFCURB (Full Perimeter) RXSG-AXA14, RXSG-AXA24 - for the "X" cabinet

Hinged corners make for fast, easy set-up

### RXSG-AXA14 (14" [356 mm] Height)

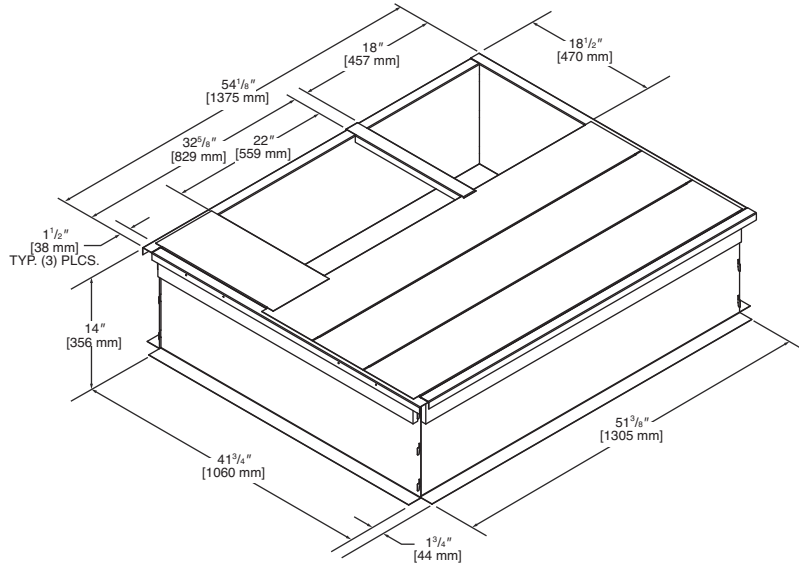

Illustration  
ST-A1334-14-00

### RXSG-AXA24 (24" [610 mm] Height)

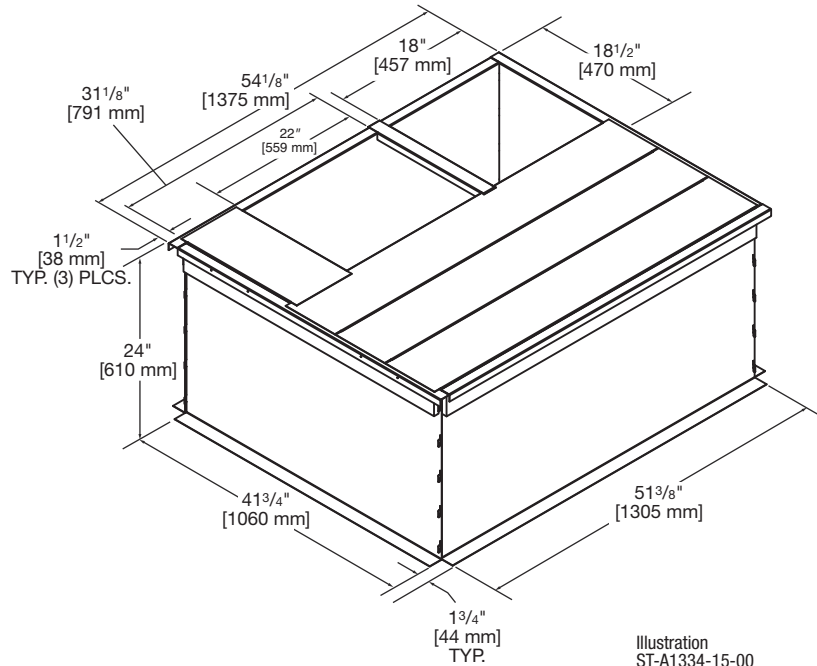

Illustration  
ST-A1334-15-00

NOTE: PERIMETER OF ROOFCURB IS SUPPLIED WITH A NORMAL 1" [25.4 mm] x 4" [102 mm] PINE NAILING STRIP.

[ ] Designates Metric Conversions



# PACKAGED AIR CONDITIONERS & PACKAGED GAS/ELECTRIC UNITS ROOFCURB INSTALLATION (Full Perimeter)

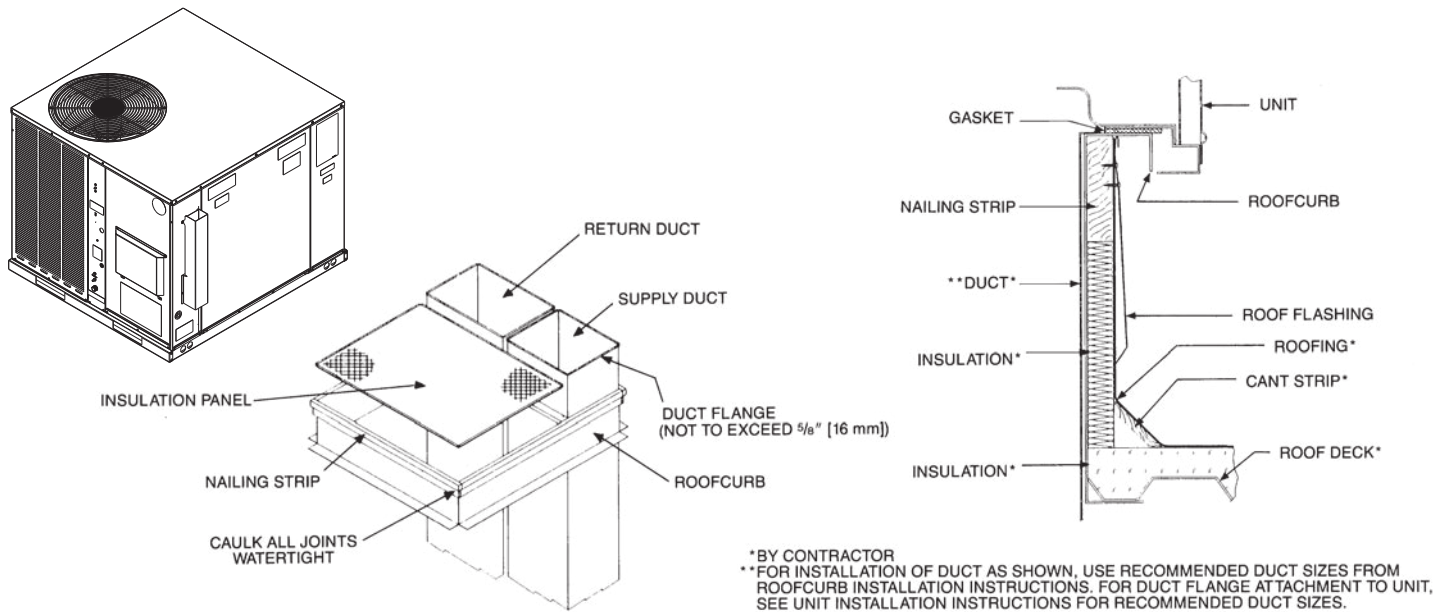

## ROOFCURB ADAPTERS

Fabricated from galvanized steel to adapt the New cabinet to the old style curb. All are furnished with a New gasket.

### OLD MODEL

### OLD CURB MODEL

### "A" CABINET TO OLD MODEL ROOF ADAPTER

### "A" CABINET PACKAGE

#### SMALL CABINET

(1½-2 TON) [5.28-7.03 KW]  
RSNC-, RSND-, RSNE-  
RRGE-, RRGF-, RRGG-, RSNY



→ RXPA-CA20 (1)

#### MEDIUM CABINET

(2½-3 TON) [8.79-10.55 KW]  
RSNC-, RSND-, RSNE-  
RRGE-, RRGF-, RRGG-, RSNY

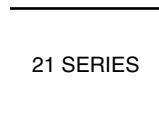

→ RXRA-DB21 (2)

#### EXTRA LARGE CABINET

(3½-5 TON) [12.31-17.58 KW]  
RSNC-, RSND-, RSNE-  
RRGE-, RRGF-, RRGG-, RSNY  
(4-5 TON) [14.07-17.58 KW]



→ RXPA-CA23 (1)  
→ RXRA-DB23 (2)

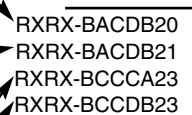

→ RGEA

(1) SLOPE TYPE  
(2) FULL PERIMETER TYPE

### "A" CABINET TO "X" CABINET ADAPTER

### "X" CABINET PACKAGE

→ RXR-DXCAE

→ RGEX-

[ ] Designates Metric Conversions

## FRESH AIR DAMPER

**AXRF-FAA1 (Fixed - 0-35%) - RGEA**  
**AXRF-FAA2 (Fixed - 0-35%) - RGEX**

The 0-35% manual outside Air Damper is designed to replace the unit return air duct cover. No drilling or damper assembly is required. The amount of outside air (0-35%) is controlled by simply adjusting the side damper.

**AXRF-FAB1 (Motorized - 0-35%) - RGEA**  
**AXRF-FAB2 (Motorized - 0-35%) - RGEX**

The 0-35% motorized outside Air Damper is designed to replace the unit return air duct cover. No drilling or damper assembly is required. The control motor opens the adjustable slide damper when the unit blower motor is energized.

**AXRF-FAA1**  
**AXRF-FAB1**

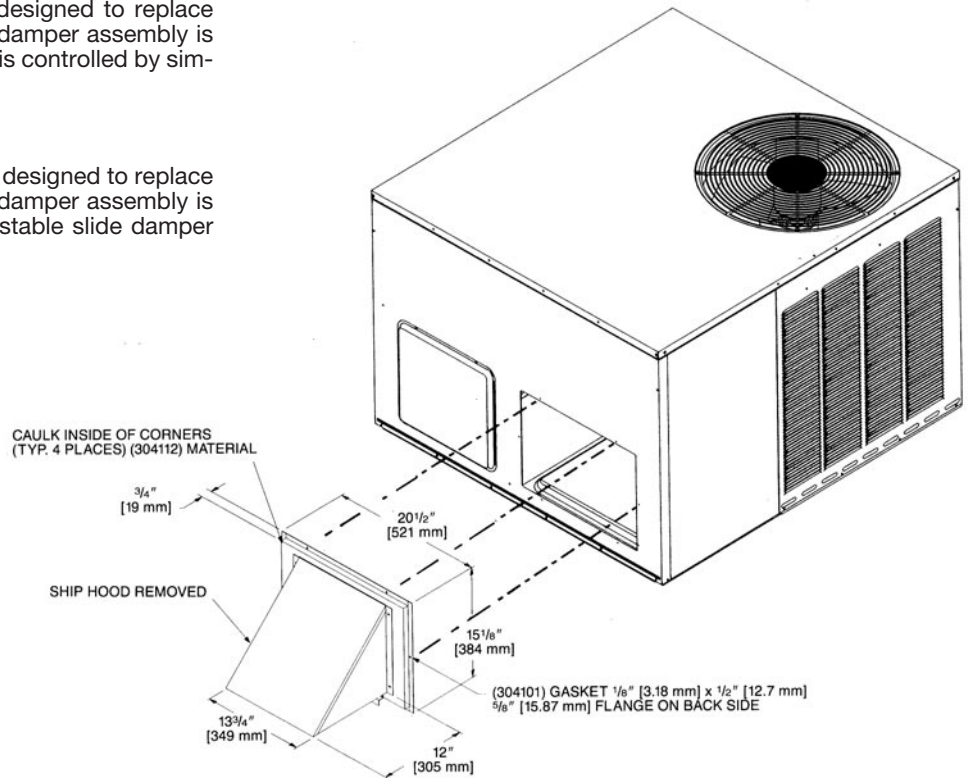

**AXRF-FAA2**  
**AXRF-FAB2**

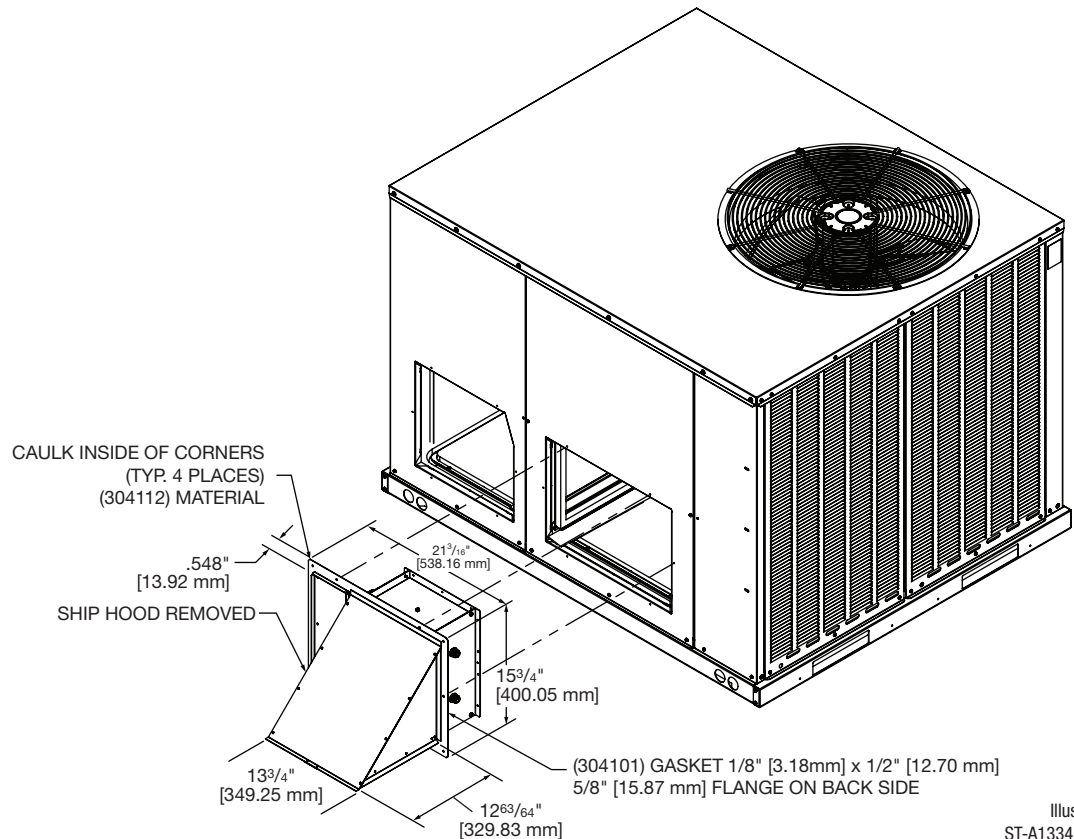

Illustration  
ST-A1334-12-00

[ ] Designates Metric Conversions

## ECONOMIZERS

### AXRD-01RACAM3 (Fully Modulating)

Horizontally and Vertically Applicable for the "A" cabinet

- LCD Screen for Continuous diagnostic and system status
- Programmable set points for accurate positioning
- Simplified wiring and color coded terminals
- Onboard fault detection and diagnostics (FDD)
- Operational Checkout to verify installation
- Enthalpy sensors and actuator that communicate through a Sylk Bus Network with the Jade Controller reducing wiring errors while providing more information
- CO<sub>2</sub> sensor input for DCV (Demand Control Ventilation) applications
- RXRX-AV04 Dual Enthalpy kit available for field installation
- AMCA licensed class 1A low leak Dampers

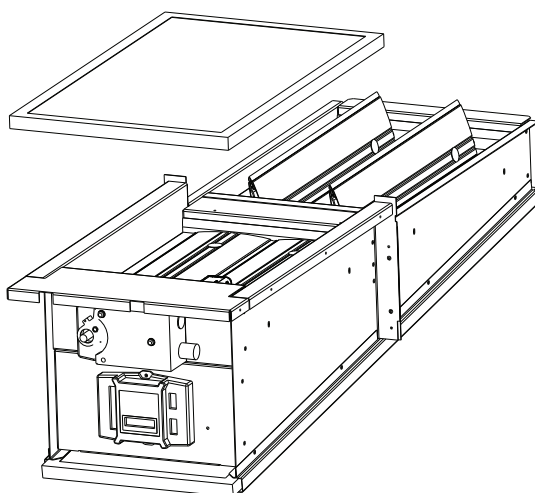
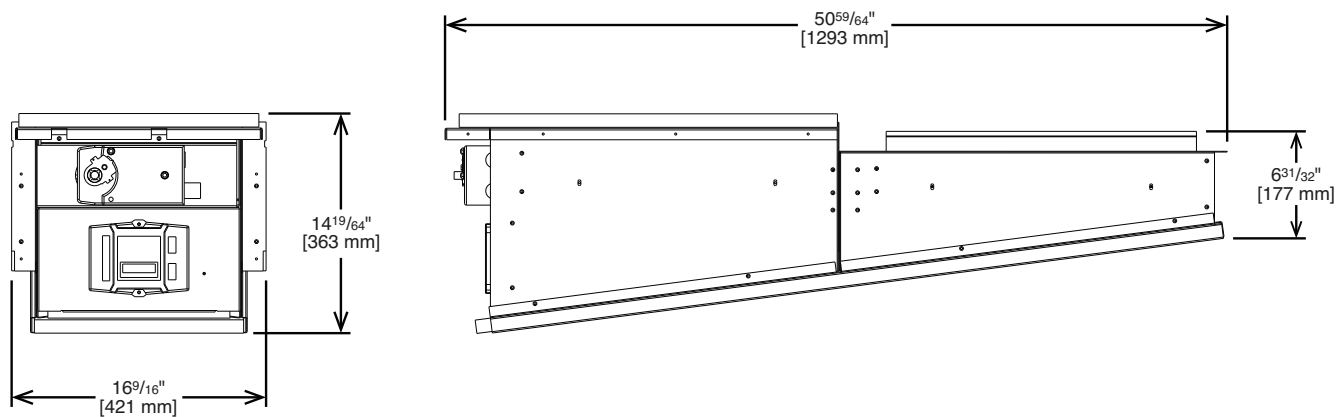
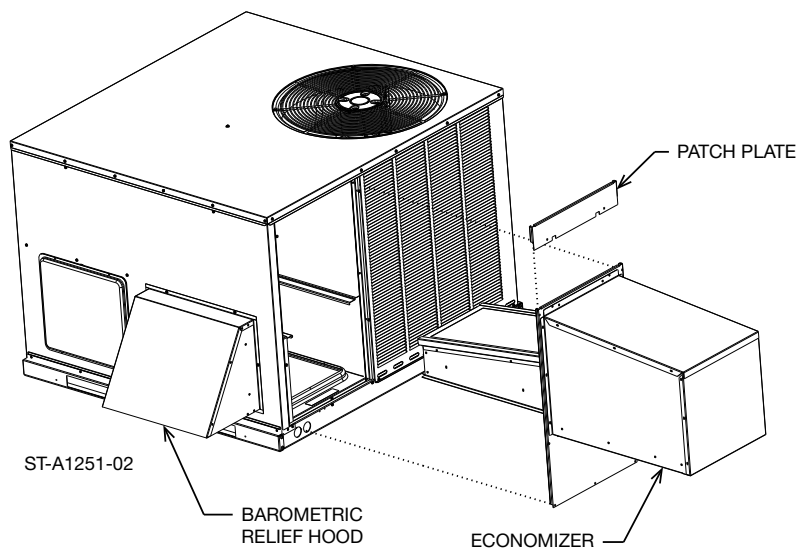

Illustration  
ST-A1251-11

[ ] Designates Metric Conversions

# ECONOMIZERS

## RXRE-11RXCAM3

Horizontally and Vertically Applicable for the "X" cabinet

- LCD Screen for Continuous diagnostic and system status
- Programmable set points for accurate positioning
- Simplified wiring and color coded terminals
- Onboard fault detection and diagnostics (FDD)
- Operational Checkout to verify installation
- Enthalpy sensors and actuator that communicate with Siemens controller reducing wiring errors while providing more information
- Setup and configure the economizer controller before putting it into usage by using the Climatix Mobile app or the inbuilt display
- CO<sub>2</sub> sensor input for demand control ventilation (DCV) applications
- RXRX-BV03 dual enthalpy kit available for field installation
- AMCA licensed class 1A low leak dampers

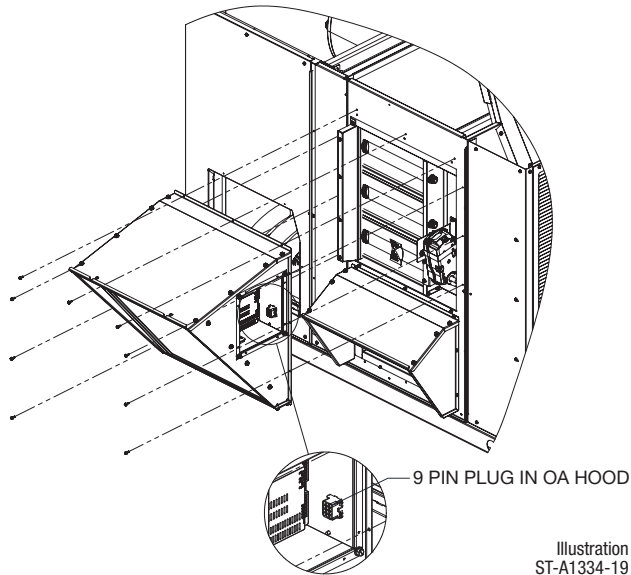
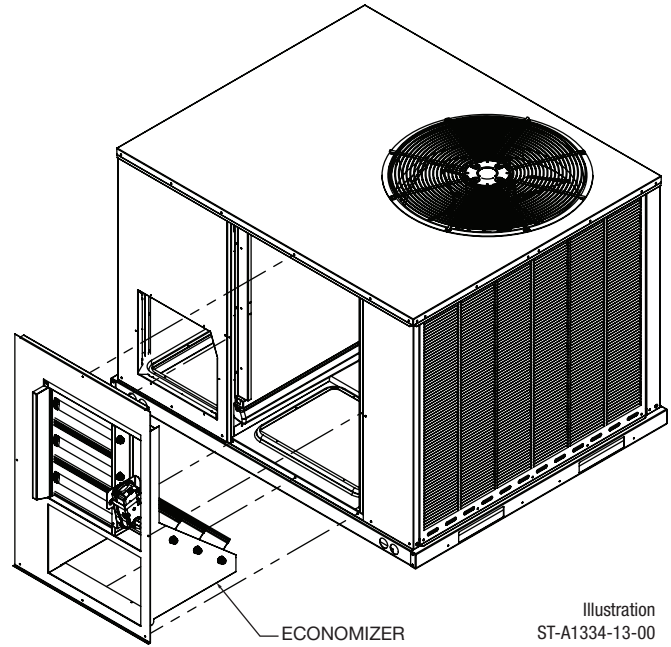

### VERTICAL APPLICATION

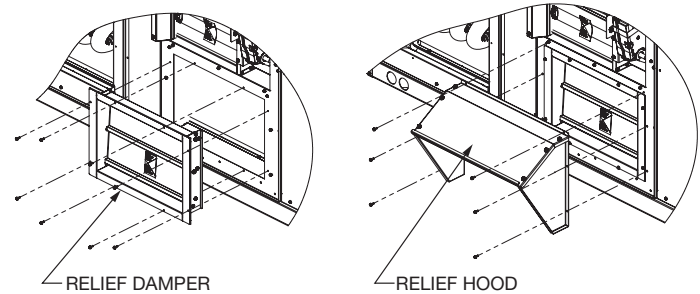

### HORIZONTAL APPLICATION

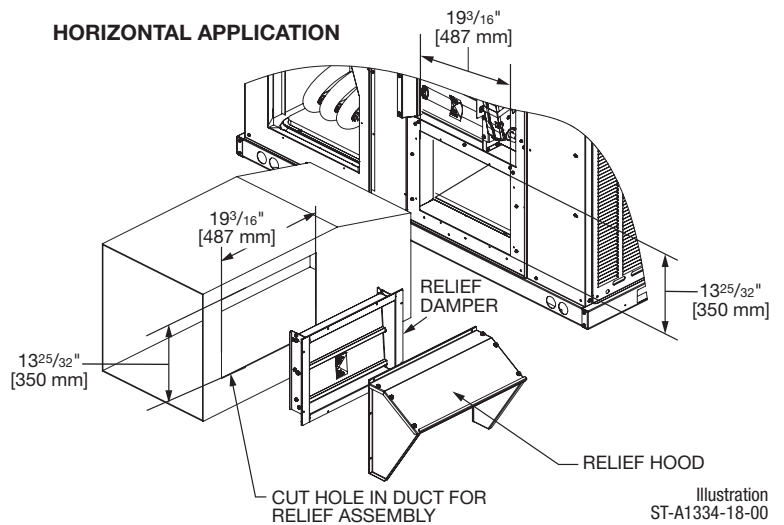

[ ] Designates Metric Conversions

## FILTER KIT INSTALLATION

### RXRY-B01

For use in either vertical or horizontal discharge with the "A" cabinet

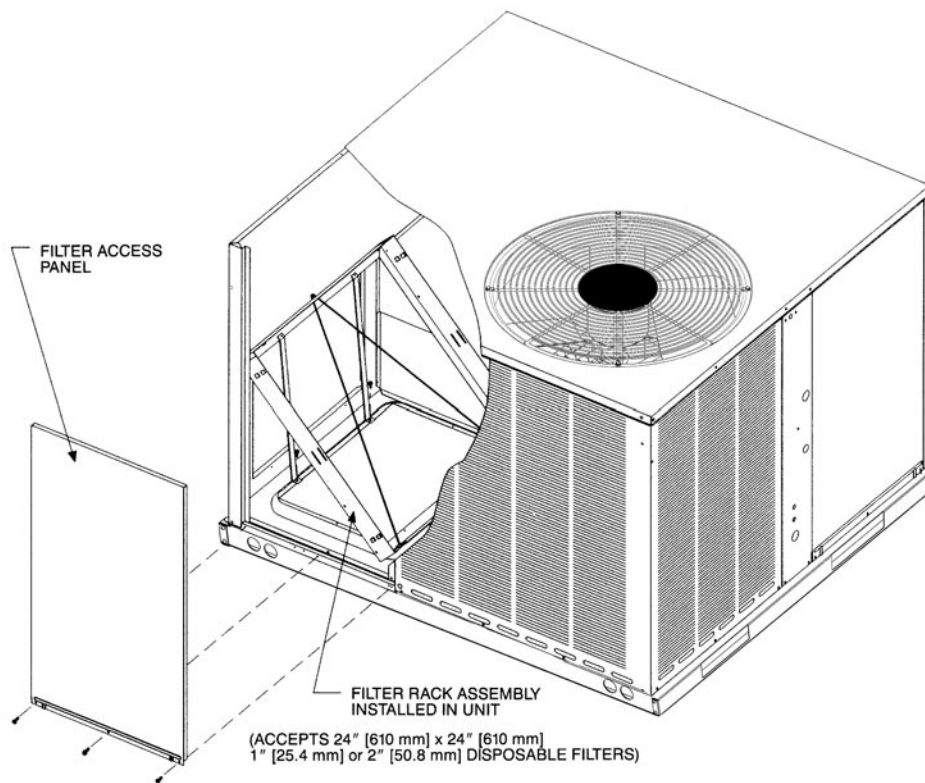

Airflow Pressure Drop, Inches W.C. [kPa]		
CFM [L/s]	1" Filter	2" Filter
500 [236]	.02 [.0050]	.03 [.0075]
600 [283]	.02 [.0050]	.03 [.0075]
700 [330]	.03 [.0075]	.04 [.0101]
800 [378]	.04 [.0101]	.05 [.0124]
900 [425]	.05 [.0124]	.06 [.0149]
1000 [472]	.07 [.0174]	.08 [.0199]
1100 [519]	.08 [.0199]	.09 [.0224]
1200 [566]	.10 [.0249]	.12 [.0299]
1300 [614]	.13 [.0324]	.15 [.0373]
1400 [661]	.16 [.0398]	.19 [.0473]
1500 [708]	.19 [.0473]	.21 [.0523]
1600 [755]	.20 [.0498]	.23 [.0572]
1700 [802]	.21 [.0523]	.24 [.0598]
1800 [850]	.22 [.0548]	.25 [.0623]
1900 [897]	.24 [.0598]	.27 [.0672]
2000 [944]	.26 [.0647]	.29 [.0722]

[ ] Designates Metric Conversions

## FILTER KIT INSTALLATION

### RXRY-B02

For use in either vertical or horizontal discharge with the "X" cabinet

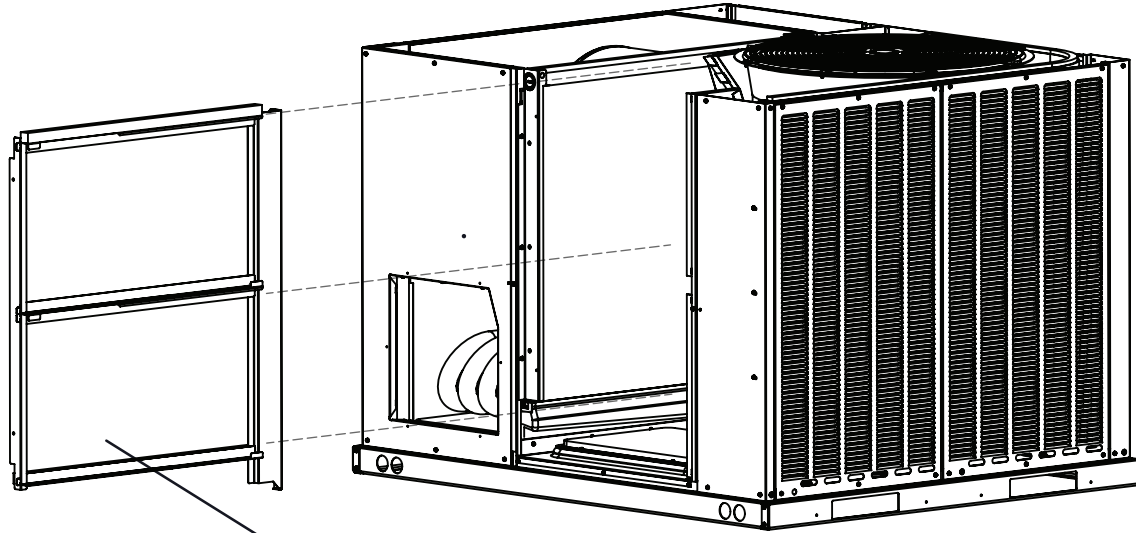

(ACCEPTS 16" [406 mm] X 30" [762 mm]  
1" [25.4 mm] DISPOSABLE FILTERS)

Illustration  
ST-A1352-01-00A

Airflow Pressure Drop (1" filter)	
CFM [L/s]	Inches W.C. [kPa]
600 [283]	0.01 [0.002]
800 [378]	0.01 [0.002]
1000 [472]	0.02 [0.005]
1200 [566]	0.03 [0.008]
1400 [661]	0.05 [0.012]
1600 [755]	0.07 [0.017]
1800 [850]	0.08 [0.021]
2000 [944]	0.10 [0.026]

[ ] Designates Metric Conversions



engineered for life™

### GENERAL TERMS OF LIMITED WARRANTY\*

Rheem will furnish a replacement for any part of this product which fails in normal use and service within the applicable periods stated, in accordance with the terms of the limited warranty.

#### Heat Exchanger

- Factory Standard .....Ten (10) Years
- Stainless Steel
- Commercial Application.....Twenty (20) Years
- Stainless Steel
- Residential Application.....Limited Lifetime

#### Conditional Parts (Registration Required)

- Residential Applications .....Ten (10) Years

#### Compressor

- Residential Applications .....Ten (10) Years
- Commercial Applications .....Five (5) Years

#### Parts

- Commercial Applications.....One (1) Year

\*For complete details of the Limited and Conditional Warranties, including applicable terms and conditions, contact your local contractor or the Manufacturer for a copy of the product warranty certificate.

**Before proceeding with installation, refer to installation instructions packaged with each model, as well as complying with all Federal, State, Provincial, and Local codes, regulations, and practices.**

© 2025 Rheem Manufacturing Company. Trademarks are property of their respective owners.

In keeping with its policy of continuous progress and product improvement, manufacturer reserves the right to make changes without notice.

5600 Old Greenwood Road  
Fort Smith, Arkansas 72908 • Rheem.com

125 Edgeware Road, Unit 1  
Brampton, Ontario • L6Y 0P5 • Rheem.ca