



Air

Packaged Air Conditioner
RLRL-H Series

The new degree of comfort.™

Rheem Commercial *Prestige*® Series Packaged Air Conditioner



RLRL-H Series

With ClearControl™
and VFD Technology

Nominal Sizes 15 & 20 Tons [52.8 & 70.3 kW]

ASHRAE 90.1-2019 Compliant



INTEGRATED AIR & WATER

FORM NO. S11-965 REV. 5

TABLE OF CONTENTS

Unit Features & Benefits	3-7
Model Number Identification	8
Options.....	9
Selection Procedure	10
General Data	
RLRL-H Series.....	11-12
Gross Systems Performance Data	
RLRL-H Series.....	13-14
Indoor Airflow Performance	
RLRL-H Series.....	15-18
Electrical Data	
RLRL-H Series.....	19-20
Electric Heater Kits	21-22
Dimensional Data	23-29
Accessories	30-43
Mechanical Specifications	44-49
Limited Warranty	50



RLRL-H STANDARD FEATURES INCLUDE:

- R-410A HFC refrigerant.
- Complete factory charged, wired and run tested.
- Scroll compressors with internal line break overload and high-pressure protection.
- Two-stage operation, two independent circuits.
- Convertible airflow – vertical downflow or horizontal sideflow.
- TXV refrigerant metering system on each circuit.
- High Pressure and Low Pressure/Loss of charge protection standard on all models.
- Solid Core liquid line filter drier on each circuit.
- Single slab, single pass designed evaporator and condenser coils facilitate easy cleaning for maintaining high efficiencies.
- Cooling operation up to 125 degree F ambient.
- Foil faced insulation encapsulated throughout entire unit minimizes airborne fibers from the air stream.
- Hinged major access door with heavy-duty gasketing, 1/4 turn latches and door retainers.
- Slide Out Indoor fan assembly for added service convenience.
- Powder Paint Finish meets ASTM B117 steel coated on each side for maximum protection. G90 galvanized.
- Base pan with drawn supply and return opening for superior water management.
- Forkable base rails for easy handling and lifting.
- Single point electrical connections.
- Internally sloped slide out condensate pan conforms to ASHRAE 62 standards.
- High performance belt drive motor with variable pitch pulleys and quick adjust belt system.
- Permanently lubricated evaporator, condenser and gas heat inducer motors.
- Condenser motors are internally protected, totally enclosed with shaft down design.
- 2 inch filter standard with slide out design.
- 24 volt control system with resettable circuit breakers.
- Colored and labeled wiring.
- Copper tube/Aluminum Fin Evaporator coils.
- MicroChannel condenser coil.
- Supplemental electric heat provides 100% efficient heating.
- Factory Installed ClearControl™ (DDC) and sensors which can connect to LonWorks™ or BACnet® BAS systems for remote monitoring and control.
- -H models with supply fan Variable Frequency Drive (VFD) meets ASHRAE 90.1-2010 and California Title 24.
- MERV 8 & MERV 13 filters are available as an accessory.
- Standard Modbus interface.



Rheem Packaged equipment is designed from the ground up with the latest features and benefits required to compete in today's market. The clean design stands alone in the industry and is a testament to the quality, reliability, ease of installation and serviceability that goes into each unit. Outwardly, the large Rheem *Commercial Series*™ label (1) identifies the brand to the customer. The sheet-metal cabinet (2) uses nothing less than 20-gauge material for structural components with an underlying coat of G90. To ensure the leak-proof integrity of these units, the design utilizes a top with a 1/8" drip lip (3), gasket-protected panels and screws. (4) The outdoor coil is slanted to protect from hail. Every Rheem packaged unit uses the toughest finish in the industry, using electro deposition baked-on enamel tested to withstand a rigorous 1000-hour salt spray test, per ASTM B117.

Anything built to last must start with the right foundation. In this case, the foundation is 14-gauge, commercial-grade, full-perimeter base rails (5), which integrate fork slots and rigging holes to save set-up time on the job site. The base pan is stamped, which forms a 1-1/8" flange around the supply and return cover and has eliminated the worry of water entering the conditioned space (6). The drainpan (7) is made of plastic that resists the growth of harmful bacteria and is sloped for the latest IAQ benefits. Furthermore, the drain pan slides out for easy cleaning. The insulation has been placed on the underside of the basepan, removing areas that would allow for potential moisture accumulation, which can facilitate growth of harmful bacteria. All insulation is secured with both adhesive and mechanical fasteners, and all edges are hidden.

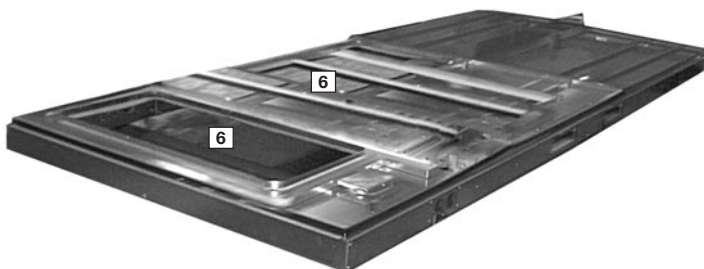

During development, each unit was tested to U.L. 1995, AHRI 340-360 and other Rheem-required reliability tests. Rheem adheres to stringent ISO 9001:2015 quality procedures, and each unit bears the U.L. and AHRI certification labels located on the unit nameplate (8). Contractors can rest assured that when a Rheem packaged unit arrives at the job, it is ready to go with a factory charge and quality checks.

Access to all major compartments is from the front of the unit, including the filter and electrical compartment, blower compartment, heating section, and outdoor section. Each panel is permanently embossed with the compartment name (control/filter access, blower access and furnace access).

Electrical and filter compartment access is through a large, hinged-access panel with 1/4 turn latches. On the outside of the panel is the unit nameplate, which contains the model and serial number, electrical data and other important unit information.

The unit charging chart is located on the inside of the electrical and filter compartment door. Electrical wiring diagrams are found on the control box cover, which allows contractors to move them to more readable locations. To the right of the control box the model and serial number can be found. Having this information on the inside will assure model identification for the life of the product. The production line quality test assurance label is also placed in this location (9). The two-inch throwaway filters (10) are easily removed on a tracked system for easy replacement.

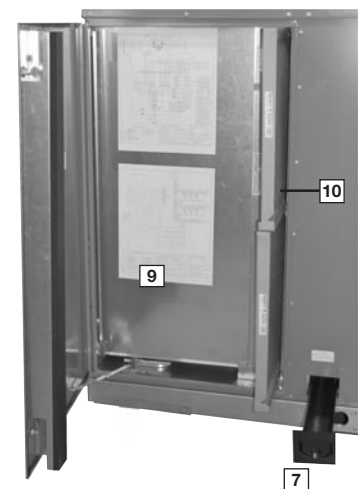



Inside the control box (10), each electrical component is clearly identified with a label that matches the component to the wire diagram for ease of trouble shooting. All wiring is numbered on each end of the termination and color-coded to match the wiring diagram. The control transformer has a low voltage circuit breaker that trips if a low voltage electrical short occurs. There is a blower contactor and contactor for each compressor.

As part of the ClearControl™ system which allows real time monitoring and communication between rooftop units, the RLRL-H Packaged Air Conditioner has a Rooftop Unit Controller (RTU-C) factory mounted and wired in the control panel. The RTU-C is a solid-state microprocessor-based control board that provides flexible control and extensive diagnostics for all unit functions. The RTU-C through proportional/integral control algorithms perform specific unit functions that govern unit operation in response to: zone conditions, system temperatures, system pressures, ambient conditions and electrical inputs. The RTU-C features a 16 x 2 character LCD display and a five-button keypad for local configuration and direct diagnosis of the system (12). New features include a clogged filter switch (CFS), fan proving switch (FPS), return air temperature sensor (RAT), discharge air temperature sensor (DAT) and outdoor air temperature sensor (OAT). Freeze sensors (FS) are used in place of freezestats to allow measurement of refrigerant suction line temperatures. The RLRL-H Packaged Air Conditioner with the ClearControl™ is specifically designed to be applied in four distinct applications:



The RLRL-H is compatible with a third party building management system that supports the BACnet Application Specific Controller device profile, with the use of a field installed BACnet Communication Module. The BACnet Communication Module plugs into the unit RTU-C controller and allows communication between ClearControl™ and the BACnet MSTP or IP network. A zone sensor, a BACnet network zone sensor, a BACnet thermostat or DDC controller may be used to send the zone temperature or thermostat demands to the RTU-C. The BACnet Communication Module is compatible with MSTP EIA-485 daisy chain networks communicating at 38.4 bps. It is compatible with twisted pair, shielded cables.

The RLRL-H is compatible with a third party building management system that supports the LonMark Space Comfort Controller (SCC) functional profile or LonMark Discharge Air Controller (DAC) functional profile. This is accomplished with a field installed LonMark communication module. The LonMark Communication Module plugs onto the RTU-C controller and allows communication between ClearControl™ and a LonWorks Network. A zone sensor, a LonTalk network zone sensor, or a LonTalk thermostat or DDC controller may be used to send the zone temperature or thermostat demands to the RTU-C. The LonMark Communication Module utilizes an FTT-10A free topology transceiver communicating at 78.8 kbps. It is compatible with Echelon qualified twisted pair cable, Belden 8471 or NEMA Level 4 cables. The Module can communicate up to 1640 ft. with no repeater. The LonWorks limit of 64 nodes per segment applies to this device.

The RLRL-H is compatible with a programmable 24 volt thermostat. Connections are made via conventional thermostat screw terminals. Extensive unit status and diagnostics are displayed on the LCD screen of the RTU-C.

The RLRL-H is compatible with a zone sensor and mechanical or solid state time clock connected to the RTU-C. Extensive unit status and diagnostics are displayed on the LCD screen of the ClearControl™.

A factory or field installed Comfort Alert® module is available for power phase-monitoring protection and additional compressor diagnostics. The alarms can be displayed on the ClearControl™ display, through the (BAS) network, or connected to the "L-Terminal" of a thermostat for notification.

All models have factory installed supply fan VFD (13) (variable frequency drive) optimizes energy year round by providing a lower speed for first stage cooling operation improving IEER's by up to 33% over the conventional constant fan system. Furthermore, operating in the constant fan mode at the reduced speed can use as little as 1/8th of the energy of a conventional constant fan system. Also, by operating at a lower speed on first stage cooling up to 126% more moisture is removed improving comfort during low load operation. The VFD equipped units meet California Title 24 and ASHRAE 90.1-2010 requirements for multi blower speed control. VFD also ramps up to the desired speed reducing stress on the supply fan components and reducing the noise from sudden inrush of air. Because the airflow is cut in half during first stage cooling and constant fan operation, noise is much less during these modes of operation.

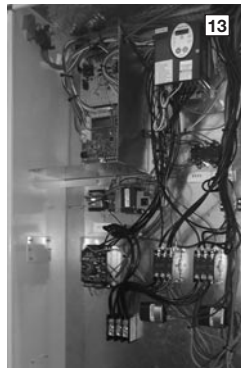

For added convenience in the field, a factory-installed convenience outlet (14) is available. Low and High voltage can enter either from the side or through the base. Low-voltage connections are made through the low-voltage terminal strip. For ease of access, the U.L.-required low voltage barrier can be temporarily removed for low-voltage termination and then reinstalled. The high-voltage connection is terminated at the high voltage terminal block. The suggested mounting for the field-installed disconnect is on the exterior side of the electrical control box.



The blower compartment is to the right of the control box and can be accessed by 1/4 turn latches. To allow easy maintenance of the blower assembly, the entire assembly easily slides out by removing four #10 screws from

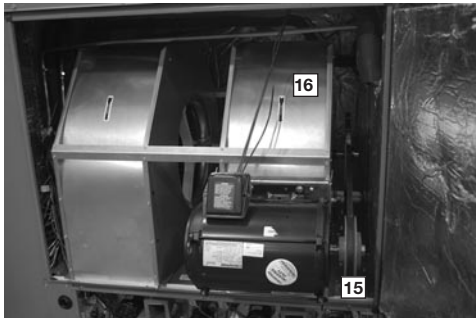

the blower assembly. The adjustable motor pulley (15) can easily be adjusted by loosening the bolts on either side of the motor mount. Removing the bolts allows for easy removal of the blower pulley by pushing the blower assembly up to loosen the belt. Once the pulley is removed, the motor sheave can be adjusted to the desired number of turns, ranging from 1 to 6 turns open. Where the demands for the job require high static, Rheem has high-static drives available that deliver nominal airflow up to 2" of static. By referring to the airflow performance tables listed in the installation instructions, proper static pressure and CFM requirements can be dialed in. The scroll housing (16) and blower scroll provide quiet and efficient airflow. The blower sheave is secured by an "H" bushing which firmly secures the pulley to the blower shaft for years of trouble-free operation. The "H" bushing allows for easy removal of the blower pulley from the shaft, as opposed to the use of a set screw, which can score the shaft, creating burrs that make blower-pulley removal difficult.

Also inside the blower compartment are the optional low-ambient controls (17). The optional low-ambient controls allow for operation of the compressors down to 0 degrees ambient temperature by cycling the outdoor fans on high pressure. The freeze sensor protects the compressor if the evaporator coil gets too cold (below freezing) due to low airflow, and allows monitoring of the suction line temperature on the controller display. The sensor clips on the suction line near the evaporator outlet.



Inside the blower compartment the interlaced evaporator can also be viewed. The evaporator uses enhanced fin technology for maximum heat transfer. The TXV metering device assures even distribution of refrigerant throughout the evaporator.

Wiring throughout the unit is neatly bundled and routed. Where wire harnesses go through the condenser bulkhead or blower deck, a molded wire harness assembly (18) provides an airtight and water-tight seal, and provides strain relief. Care is also taken to tuck raw edges of insulation behind sheet metal to improve indoor air quality.

The heating compartment contains the latest electric furnace technology on the market. The 100% efficient electric furnace can be factory-installed or easily field-installed. Built with ease-of-installation in mind, the electric furnace is completely wired up for slide-in, plug-and-play installation in the field. With choices of up to four kilowatt offerings, the contractor is assured to get the correct amount of heating output to meet the designed heating load.

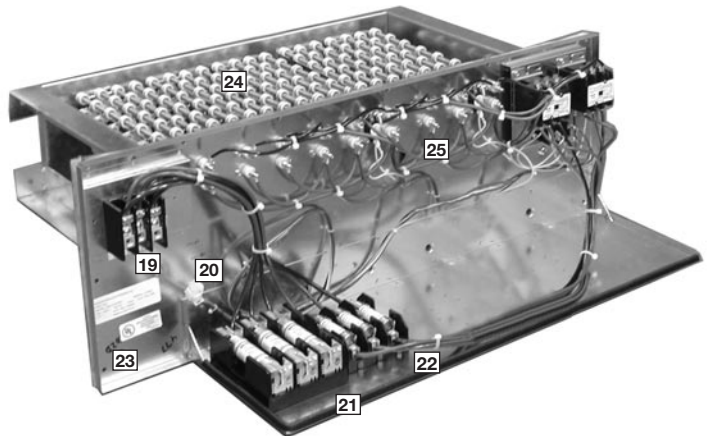

Power hook-up in the field is easy with single-point wiring to a terminal block (19) and a polarized plug for the low-voltage connection (20). The electric furnace comes with fuses for the unit (21) and for the electric furnace (22), and is UL certified (23). The electric heating elements are of a wound-wire construction (24) and isolated with ceramic bushings. The limit switch (25) protects the design from over-temperature conditions.

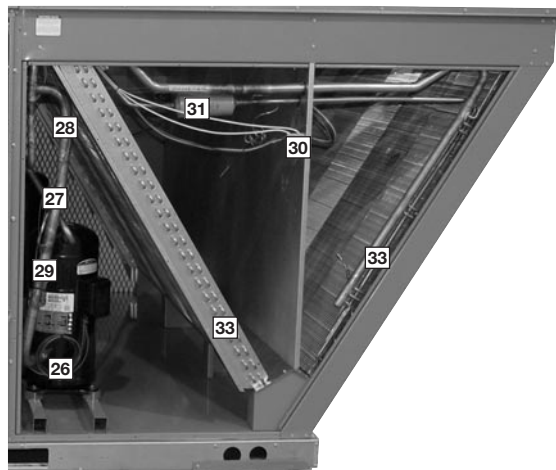

The compressor compartment houses the heartbeat of the unit. The scroll compressor (26) is known for its long life, and for reliable, quiet, and efficient operation. The suction and discharge lines are designed with shock loops (27) to absorb the strain and stress that the starting torque, steady state operation, and shut down cycle impose on the refrigerant tubing. Each compressor and circuit is independent for built-in redundancy, and each circuit is clearly marked throughout the system. Each unit has two stages of efficient cooling operation, first stage is approximately 50% of second stage.

In the outdoor section are the external gauge ports (28). With the gauge ports mounted externally, an accurate diagnosis of system operation can be performed quickly and easily. Also located in this area are the refrigerant safety devices: the low-pressure switches (29) and the high-pressure switches. (30) The high-pressure switches will shut off the compressors if pressures exceeding 610 psig are detected as may occur if the outdoor fan motor fails. The low pressure switches shut off the compressors if low pressure is detected due to loss of refrigerant charge. The factory-installed high and low pressure switches are brazed into the appropriate high or low side and wired appropriately.

Each unit comes standard with filter dryer (31). The condenser fan motor (32) can easily be accessed and maintained by removing the protective fan grille. The polarized plug connection allows the motor to be changed quickly and eliminates the need to snake wires through the unit.

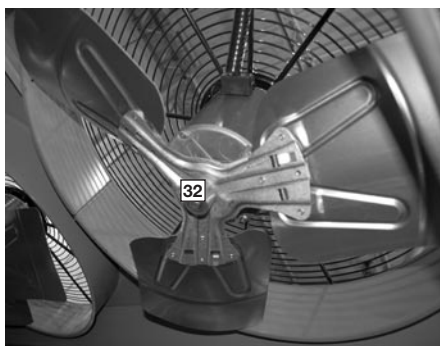

The outdoor coil uses the latest enhanced fin design (33) for the most effective method of heat transfer. The outdoor coil is slanted to protect the unit from Mother Nature.

Each unit is designed for both downflow or horizontal applications (34) for job configuration flexibility. The return air compartment

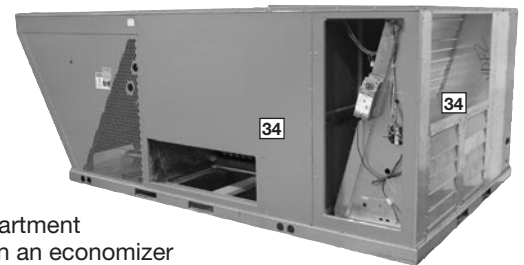

can also contain an economizer (35). Three models exist; two for downflow applications, and one for horizontal applications. (A downflow economizer with factory installed smoke detector in the return section is available). Each unit is pre-wired for the economizer to allow quick plug-in installation. The downflow economizer is also available as a factory-installed option. The economizer, which provides free cooling when outdoor conditions are suitable and also provides fresh air to meet local requirements, comes standard with single enthalpy controls. The controls can be upgraded to dual enthalpy easily in the field. The direct drive actuator combined with gear drive dampers has eliminated the need for linkage adjustment in the field. The economizer control has a minimum position setpoint, an outdoor-air setpoint, a mix-air setpoint, and a CO₂ setpoint. Barometric relief is standard on all economizers. Power Exhaust is easily field-installed. The power exhaust is housed in the

barometric relief opening and is easily slipped in with a plug-in assembly. The wire harness to the economizer also has accommodations for a smoke detector.



The damper minimum position, actual damper position, power exhaust on/off setpoint, mixed air temperature limit setpoint and Demand Controlled Ventilation (DCV) setpoint can be read and adjusted at the unit controller display or remotely through a network connection.

The Space CO₂ level, mixed air temperature, and Economizer Status (Free Cooling Available, Single or Dual Enthalpy) can be read at the unit controller display or remotely through a network connection. Economizer Faults will trigger a network Alarm and can be read at the unit controller display or remotely through a network connection.

The Rheem roofcurb (36) is made for toolless assembly at the jobsite by inserting a pin into the hinged corners (37), which makes the assembly process quick and easy.

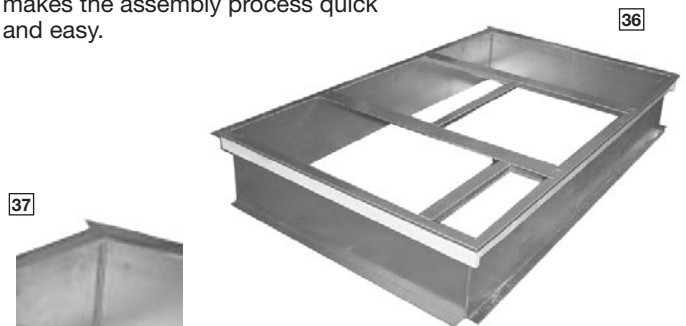

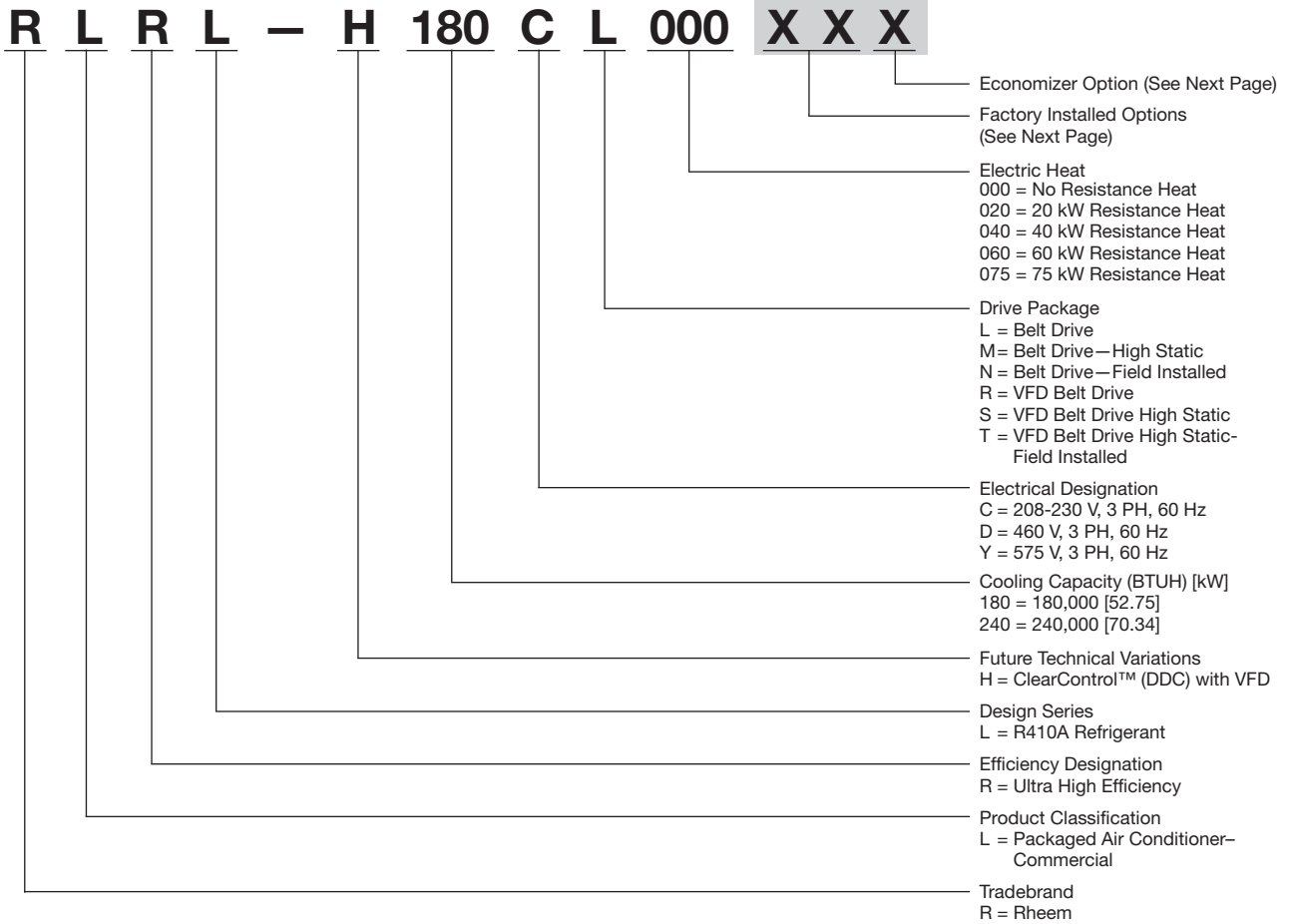

[] Designates Metric Conversions



FACTORY INSTALLED OPTION CODES FOR RLRL-H (15 & 20 TON) [52.8 & 70.3 kW]

Option Code	Hail Guard	Non-Powered Convenience Outlet	Low Ambient/Comfort Alert
AA		NO OPTIONS	
AD	X		
AG		X	
AR			X
JD	X		X
BJ	X	X	
JE		X	X
CZ	X	X	X

Example: RLRL-H180CL000XXX (where XX is factory installed option)

Example: No Options

RLRL-H180CL000

Example: No Options with factory installed economizer

RLRL-H180CL000AAH

Example: Options with low ambient/comfort alert and no factory installed economizer

RLRL-H180CL000ARA

Example: Options same as above with factory installed economizer

RLRL-H180CL000ARH

ECONOMIZER SELECTION FOR RLRL-H (15 & 20 TON) [52.8 & 70.3 kW]

Option Code	No Economizer	DDC Single Enthalpy Economizer* With Barometric Relief	DDC Single Enthalpy Economizer* With Barometric Relief and Smoke Detector
A	X		
H		X	
J			X

"x" indicates factory installed option.

*Downflow economizer only.

Instructions for Factory Installed Option(s) Selection

Note: Three characters following the model number will be utilized to designate a factory-installed option or combination of options. If no factory option(s) is required, nothing follows the model number.

Step 1. After a basic rooftop model is selected, choose a *two-character* option code from the FACTORY INSTALLED OPTION SELECTION TABLE.

Proceed to Step 2.

Step 2. The last option code character is utilized for factory-installed economizers. Choose a character from the FACTORY INSTALLED ECONOMIZER SELECTION TABLE.

Examples:

RLRL-H180CL000this unit has no factory installed options.

RLRL-H180CL000ARAthis unit is equipped with low ambient/comfort alert.

RLRL-H180CL000ARHthis unit is equipped with low ambient/comfort alert and economizer with single enthalpy sensor and barometric relief.

RLRL-H180CL000AAJthis unit is equipped with an Economizer with single enthalpy sensor and barometric relief with smoke detector.

[] Designates Metric Conversions



To select an RLRL-H Cooling and Heating unit to meet a job requirement, follow this procedure, with example, using data supplied in this specification sheet.

1. DETERMINE COOLING AND HEATING REQUIREMENTS AND SPECIFIC OPERATING CONDITIONS FROM PLANS AND SPECS.

Example:

Voltage—	240 V – 3 Phase – 60 Hz
Total Cooling Capacity—	205,000 BTUH [60.0 kW]
Sensible Cooling Capacity—	155,000 BTUH [45.4 kW]
Heating Capacity—	235,000 BTUH [68.8 kW]
*Condenser Entering Air—	95°F [35°C] DB
*Evaporator Mixed Air Entering—	65°F [18.3] WB; 78°F [25.6] DB
*Indoor Air Flow (vertical)—	7200 CFM [3398 L/s]
*External Static Pressure—	0.70 in. WG [.17 kPa]

2. SELECT UNIT TO MEET COOLING REQUIREMENTS.

Since total cooling is within the range of a nominal 20 ton [70.3 kW] unit, enter cooling performance table at 95°F [35.0 °C] DB condenser inlet air. Interpolate between 63°F [17.2 °C] WB and 67°F [19.4 °C] WB to determine total and sensible capacity and power input for 65°F [18.3 °C] WB evaporator inlet air at 7725 CFM [3645 L/s] indoor air flow (table basis):

Total Cooling Capacity = 238,300 BTUH [69.76 kW]
Sensible Cooling Capacity = 192,500 BTUH [56.38 kW]
Power Input (Compressor and Cond. Fans) = 18,200 watts

Use formula in note ① to determine sensible capacity at 78°F [25.6] DB evaporator entering air:

$$192,550 + (1.10 \times 7,200 \times (1 - 0.11) \times (78 - 80))$$

$$\text{Sensible Cooling Capacity} = 178,452 \text{ BTUH [52.25 kW]}$$

3. CORRECT CAPACITIES OF STEP 2 FOR ACTUAL AIR FLOW.

Select factors from airflow correction table at 7200 CFM [3398 L/s] and apply to data obtained in step 2 to obtain gross capacity:

Total Capacity = 238,300 x .99 = 235,868 BTUH [69.06 kW]
Sensible Capacity = 178,452 x 0.96 = 171,314 BTUH [50.16 kW]
Power Input = 18,200 x 0.99 = 18,018 Watts

These are Gross Capacities, not corrected for blower motor heat or power.

4. DETERMINE BLOWER SPEED AND WATTS TO MEET SYSTEM DESIGN.

Enter Indoor Blower performance table at 7200 CFM [3398 L/s]. Total ESP (external static pressure) per the spec of 0.70 in. WG [.17 kPa] includes the system duct and grilles. Add from the table 'Component Air Resistance', 0.01 in. WG [.00 kPa] for wet coil, 0.08 in. WG [.02 kPa] for downflow air flow, for a total selection static pressure of 0.79 (0.8) in. WG [.20 kPa], and determine:

$$\text{RPM} = 739$$

$$\text{WATTS} = 2,862$$

$$\text{DRIVE} = \text{L (standard 5 H.P. motor)}$$

5. CALCULATE INDOOR BLOWER BTUH HEAT EFFECT FROM MOTOR WATTS, STEP 4.

$$2,862 \times 3.412 = 9,765 \text{ BTUH [2.86 kW]}$$

6. CALCULATE NET COOLING CAPACITIES, EQUAL TO GROSS CAPACITY, STEP 3, MINUS INDOOR BLOWER MOTOR HEAT.

$$\text{Net Total Capacity} = 235,868 - 9,765 = 226,103 \text{ BTUH [66.21 kW]}$$

$$\text{Net Sensible Capacity} = 171,314 - 9,765 = 161,549 \text{ BTUH [47.30 kW]}$$

7. CALCULATE UNIT INPUT AND JOB EER.

$$\text{Total Power Input} = 18,018 \text{ (step 3)} + 2,862 \text{ (step 4)} = 20,880 \text{ Watts}$$

$$\text{EER} = \frac{\text{Net Total BTUH [kW] (step 6)}}{\text{Power Input, Watts (above)}} = \frac{226,103}{20,880} = 10.83$$

8. SELECT UNIT HEATING CAPACITY.

From Heater Kit Table select kW to meet heating capacity requirement; multiply kW x 3412 to convert to BTUH

Use 75 kW Heater Kit
Heater Kit Model: RXJJ-CE75C
Heater Kit Capacity: 245,323 BTUH [71.8 kW]

Add indoor blower heat effect (step 5) to Heater Kit Capacity to get total heating capacity:

$$245,323 + 9,765 = 255,088 \text{ BTUH [74.7 kW]}$$

9. CHOOSE MODEL RLRL-H240CL075

*NOTE: These operating conditions are typical of a commercial application in a 95°F/79°F [35°C/26°C] design area with indoor design of 76°F [24°C] DB and 50% RH and 10% ventilation air, with the unit roof mounted and centered on the zone it conditions by ducts.

[] Designates Metric Conversions



NOM. SIZES 15 & 20 TONS [52.8 & 70.3 kW] MODELS

Model RLRL- Series (with VFD)	H180CR	H180CS	H180DR	H180DS
Cooling Performance^A				CONTINUED →
Gross Cooling Capacity Btu [kW]	178,000 [50.63]	178,000 [50.63]	178,000 [50.63]	178,000 [50.63]
EER	11.6	11.6	11.6	11.6
IEER ^B	14.2	14.2	14.2	14.2
Nominal CFM/AHRI Rated CFM [L/s]	6000/5500 [2831/2595]	6000/5500 [2831/2595]	6000/5500 [2831/2595]	6000/5500 [2831/2595]
AHRI Net Cooling Capacity Btu [kW]	172,000 [48.92]	172,000 [48.92]	172,000 [48.92]	172,000 [48.92]
Net Sensible Capacity Btu [kW]	126,000 [35.84]	126,000 [35.84]	126,000 [35.84]	126,000 [35.84]
Net Latent Capacity Btu [kW]	46,000 [13.08]	46,000 [13.08]	46,000 [13.08]	46,000 [13.08]
Net System Power [kW]	14.83	14.83	14.83	14.83
Compressor				
No./Type	2/Scroll	2/Scroll	2/Scroll	2/Scroll
Outdoor Sound Rating (dB)^C	91	91	91	91
Outdoor Coil—Fin Type	Louvered	Louvered	Louvered	Louvered
Tube Type	MicroChannel	MicroChannel	MicroChannel	MicroChannel
Tube Size in. [mm] OD	1 [25.4]	1 [25.4]	1 [25.4]	1 [25.4]
Face Area sq. ft. [sq. m]	50.8 [4.72]	50.8 [4.72]	50.8 [4.72]	50.8 [4.72]
Rows / FPI [FPcm]	1 / 23 [9]	1 / 23 [9]	1 / 23 [9]	1 / 23 [9]
Indoor Coil—Fin Type	Louvered	Louvered	Louvered	Louvered
Tube Type	Rifled	Rifled	Rifled	Rifled
Tube Size in. [mm]	0.375 [9.5]	0.375 [9.5]	0.375 [9.5]	0.375 [9.5]
Face Area sq. ft. [sq. m]	26.67 [2.48]	26.67 [2.48]	26.67 [2.48]	26.67 [2.48]
Rows / FPI [FPcm]	2 / 18 [7]	2 / 18 [7]	2 / 18 [7]	2 / 18 [7]
Refrigerant Control	TX Valves	TX Valves	TX Valves	TX Valves
Drain Connection No./Size in. [mm]	1/1 [25.4]	1/1 [25.4]	1/1 [25.4]	1/1 [25.4]
Outdoor Fan—Type	Propeller	Propeller	Propeller	Propeller
No. Used/Diameter in. [mm]	3/24 [609.6]	3/24 [609.6]	3/24 [609.6]	3/24 [609.6]
Drive Type/No. Speeds	Direct/1	Direct/1	Direct/1	Direct/1
CFM [L/s]	10000 [4719]	10000 [4719]	10000 [4719]	10000 [4719]
No. Motors/HP	3 at 1/3 HP	3 at 1/3 HP	3 at 1/3 HP	3 at 1/3 HP
Motor RPM	1075	1075	1075	1075
Indoor Fan—Type	FC Centrifugal	FC Centrifugal	FC Centrifugal	FC Centrifugal
No. Used/Diameter in. [mm]	2/18x9 [457x229]	2/18x9 [457x229]	2/18x9 [457x229]	2/18x9 [457x229]
Drive Type	Belt (Adjustable)	Belt (Adjustable)	Belt (Adjustable)	Belt (Adjustable)
No. Speeds (Standard / VFD)	Single / Multiple	Single / Multiple	Single / Multiple	Single / Multiple
No. Motors	1	1	1	1
Motor HP	3	5	3	5
Motor RPM	1725	1725	1725	1725
Motor Frame Size	56	184	56	184
Filter—Type	Disposable	Disposable	Disposable	Disposable
Furnished	Yes	Yes	Yes	Yes
(NO.) Size Recommended in. [mm x mm x mm]	(8)2x25x20 [51x635x508]	(8)2x25x20 [51x635x508]	(8)2x25x20 [51x635x508]	(8)2x25x20 [51x635x508]
Refrigerant Charge Oz. [g] (Sys. 1/Sys. 2) [g]	170/173 [4820/4905]	170/173 [4820/4905]	170/173 [4820/4905]	170/173 [4820/4905]
Weights				
Net Weight lbs. [kg]	1883 [854]	1921 [871]	1883 [854]	1921 [871]
Ship Weight lbs. [kg]	2009 [911]	2047 [929]	2009 [911]	2047 [929]

NOTES:

- A. Cooling Performance is rated at 95° F ambient, 80° F entering dry bulb, 67° F entering wet bulb. Gross capacity does not include the effect of fan motor heat. AHRI capacity is net and includes the effect of fan motor heat. Units are suitable for operation to ±20% of nominal cfm. Units are certified in accordance with the Unitary Air Conditioner Equipment certification program, which is based on AHRI Standard 210/240 or 360.
- B. EER and Integrated Energy Efficiency Ratio (IEER) is rated at AHRI conditions in accordance with AHRI Standard 340/360.
- C. Outdoor Sound Rating shown is tested in accordance with AHRI Standard 270.
- D. 25 Ton Model is outside the scope of AHRI Standard 340/360.

[] Designates Metric Conversions

NOM. SIZES 15 & 20 TONS [52.8 & 70.3 kW] MODELS

Model RLRL- Series (with VFD)	H240CR	H240CS	H240DR	H240DS
Cooling Performance^A		CONTINUED		CONTINUED →
Gross Cooling Capacity Btu [kW]	240,000 [68.26]	240,000 [68.26]	240,000 [68.26]	240,000 [68.26]
EER	11.6	11.6	11.6	11.6
IEER ^B	14.2	14.2	14.2	14.2
Nominal CFM/AHRI Rated CFM [L/s]	8000/7375 [3775/3480]	8000/7375 [3775/3480]	8000/7375 [3775/3480]	8000/7375 [3775/3480]
AHRI Net Cooling Capacity Btu [kW]	228,000 [64.85]	228,000 [64.85]	228,000 [64.85]	228,000 [64.85]
Net Sensible Capacity Btu [kW]	167,000 [47.50]	167,000 [47.50]	167,000 [47.50]	167,000 [47.50]
Net Latent Capacity Btu [kW]	63,000 [17.92]	63,000 [17.92]	63,000 [17.92]	63,000 [17.92]
Net System Power [kW]	19.66	19.66	19.66	19.66
Compressor				
No./Type	2/Scroll	2/Scroll	2/Scroll	2/Scroll
Outdoor Sound Rating (dB)^C	91	91	91	91
Outdoor Coil—Fin Type	Louvered	Louvered	Louvered	Louvered
Tube Type	MicroChannel	MicroChannel	MicroChannel	MicroChannel
Tube Size in. [mm] OD	1 [25.4]	1 [25.4]	1 [25.4]	1 [25.4]
Face Area sq. ft. [sq. m]	50.8 [4.72]	50.8 [4.72]	50.8 [4.72]	50.8 [4.72]
Rows / FPI [FPcm]	1 / 23 [9]	1 / 23 [9]	1 / 23 [9]	1 / 23 [9]
Indoor Coil—Fin Type	Louvered	Louvered	Louvered	Louvered
Tube Type	Rifled	Rifled	Rifled	Rifled
Tube Size in. [mm]	0.375 [9.5]	0.375 [9.5]	0.375 [9.5]	0.375 [9.5]
Face Area sq. ft. [sq. m]	26.67 [2.48]	26.67 [2.48]	26.67 [2.48]	26.67 [2.48]
Rows / FPI [FPcm]	4 / 15 [6]	4 / 15 [6]	4 / 15 [6]	14 / 15 [6]
Refrigerant Control	TX Valves	TX Valves	TX Valves	TX Valves
Drain Connection No./Size in. [mm]	1/1 [25.4]	1/1 [25.4]	1/1 [25.4]	1/1 [25.4]
Outdoor Fan—Type	Propeller	Propeller	Propeller	Propeller
No. Used/Diameter in. [mm]	6/24 [609.6]	6/24 [609.6]	6/24 [609.6]	6/24 [609.6]
Drive Type/No. Speeds	Direct/1	Direct/1	Direct/1	Direct/1
CFM [L/s]	19800 [9344]	19800 [9344]	19800 [9344]	19800 [9344]
No. Motors/HP	6 at 1/3 HP	6 at 1/3 HP	6 at 1/3 HP	6 at 1/3 HP
Motor RPM	1075	1075	1075	1075
Indoor Fan—Type	FC Centrifugal	FC Centrifugal	FC Centrifugal	FC Centrifugal
No. Used/Diameter in. [mm]	2/18x9 [457x229]	2/18x9 [457x229]	2/18x9 [457x229]	2/18x9 [457x229]
Drive Type	Belt (Adjustable)	Belt (Adjustable)	Belt (Adjustable)	Belt (Adjustable)
No. Speeds (Standard / VFD)	Single / Multiple	Single / Multiple	Single / Multiple	Single / Multiple
No. Motors	1	1	1	1
Motor HP	5	7 1/2	5	7 1/2
Motor RPM	1725	1725	1725	1725
Motor Frame Size	184	213	184	184
Filter—Type	Disposable	Disposable	Disposable	Disposable
Furnished	Yes	Yes	Yes	Yes
(NO.) Size Recommended in. [mm x mm x mm]	(8)2x25x20 [51x635x508]	(8)2x25x20 [51x635x508]	(8)2x25x20 [51x635x508]	(8)2x25x20 [51x635x508]
Refrigerant Charge Oz. [g] (Sys. 1/Sys. 2) [g]	271/227 [7683/6435]	271/227 [7683/6435]	271/227 [7683/6435]	271/227 [7683/6435]
Weights				
Net Weight lbs. [kg]	2151 [976]	2189 [993]	2289 [1038]	2327 [1056]
Ship Weight lbs. [kg]	2251 [1021]	2289 [1038]	2389 [1084]	2427 [1101]

NOTES:

A. Cooling Performance is rated at 95° F ambient, 80° F entering dry bulb, 67° F entering wet bulb. Gross capacity does not include the effect of fan motor heat. AHRI capacity is net and includes the effect of fan motor heat. Units are suitable for operation to ±20% of nominal cfm. Units are certified in accordance with the Unitary Air Conditioner Equipment certification program, which is based on AHRI Standard 210/240 or 360.

B. EER and Integrated Energy Efficiency Ratio (IEER) is rated at AHRI conditions in accordance with AHRI Standard 340/360.

C. Outdoor Sound Rating shown is tested in accordance with AHRI Standard 270.

D. 25 Ton Model is outside the scope of AHRI Standard 340/360.

[] Designates Metric Conversions



GROSS SYSTEMS PERFORMANCE DATA—RLRL-H180

		ENTERING INDOOR AIR @ 80°F [26.7°C] dbE ①									
wbE		71°F [21.7°C]			67°F [19.4°C]			63°F [17.2°C]			
CFM [L/s]		6050 [2855]	5500 [2596]	4675 [2206]	6050 [2855]	5500 [2596]	4675 [2206]	6050 [2855]	5500 [2596]	4675 [2206]	
DR ①		.11	.09	.06	.11	.09	.06	.11	.09	.06	
OUTDOOR DRY BULB TEMPERATURE [°F]	75 [23.9]	Total BTUH [kW]	215.9 [63.3]	212.1 [62.1]	206.3 [60.4]	202.4 [59.3]	198.8 [58.2]	193.3 [56.7]	192.6 [56.4]	189.2 [55.4]	184.0 [53.9]
		Sens BTUH [kW]	111.3 [32.6]	106.4 [31.2]	98.9 [29.0]	147.8 [43.3]	141.2 [41.4]	131.3 [38.5]	181.0 [53]	172.9 [50.7]	160.8 [47.1]
		Power	9.6	9.5	9.4	9.3	9.2	9.1	9.0	8.9	8.8
	80 [26.7]	Total BTUH [kW]	212.0 [62.1]	208.2 [61.0]	202.5 [59.3]	198.4 [58.1]	194.8 [57.1]	189.5 [55.5]	188.6 [55.3]	185.3 [54.3]	180.2 [52.8]
		Sens BTUH [kW]	109.8 [32.2]	104.9 [30.7]	97.5 [28.6]	146.2 [42.8]	139.7 [40.9]	129.9 [38.1]	179.4 [52.6]	171.4 [50.2]	159.4 [46.7]
		Power	10.4	10.3	10.2	10.1	10.0	9.9	9.8	9.7	9.6
	85 [29.4]	Total BTUH [kW]	207.2 [60.7]	203.5 [59.6]	198.0 [58.0]	193.7 [56.8]	190.2 [55.7]	185.0 [54.2]	183.9 [53.9]	180.6 [52.9]	175.7 [51.5]
		Sens BTUH [kW]	107.8 [31.6]	103.0 [30.2]	95.8 [28.1]	144.2 [42.3]	137.8 [40.4]	128.1 [37.5]	177.4 [52.0]	169.5 [49.7]	157.6 [46.2]
		Power	11.3	11.2	11.0	11.0	10.9	10.7	10.7	10.6	10.5
	90 [32.2]	Total BTUH [kW]	201.8 [59.1]	198.2 [58.1]	192.8 [56.5]	188.2 [55.2]	184.9 [54.2]	179.8 [52.7]	178.5 [52.3]	175.3 [51.4]	170.5 [50.0]
		Sens BTUH [kW]	105.4 [30.9]	100.7 [29.5]	93.6 [27.4]	141.8 [41.6]	135.5 [39.7]	126.0 [36.9]	175.0 [51.3]	167.2 [49.0]	155.5 [45.6]
		Power	12.2	12.1	11.9	11.9	11.8	11.6	11.6	11.5	11.4
95 [35]	Total BTUH [kW]	195.6 [57.3]	192.1 [56.3]	186.9 [54.8]	182.1 [53.4]	178.8 [52.4]	173.9 [51.0]	172.3 [50.5]	169.2 [49.6]	164.6 [48.2]	
	Sens BTUH [kW]	102.6 [30.1]	98.0 [28.7]	91.2 [26.7]	139.0 [40.7]	132.8 [38.9]	123.5 [36.2]	172.2 [50.5]	164.5 [48.2]	153.0 [44.8]	
	Power	13.1	13.0	12.8	12.9	12.7	12.6	12.6	12.5	12.3	
100 [37.8]	Total BTUH [kW]	188.7 [55.3]	185.3 [54.3]	180.3 [52.8]	175.2 [51.3]	172.0 [50.4]	167.3 [49.0]	165.4 [48.5]	162.4 [47.6]	158.0 [46.3]	
	Sens BTUH [kW]	99.4 [29.1]	95.0 [27.8]	88.3 [25.9]	135.8 [39.8]	129.8 [38.0]	120.7 [35.4]	165.4 [48.5]	161.5 [47.3]	150.2 [44.0]	
	Power	14.2	14.0	13.8	13.9	13.7	13.6	13.6	13.5	13.3	
105 [40.6]	Total BTUH [kW]	181.1 [53.1]	177.8 [52.1]	173.0 [50.7]	167.5 [49.1]	164.5 [48.2]	160.0 [46.9]	157.7 [46.2]	154.9 [45.4]	150.7 [44.2]	
	Sens BTUH [kW]	95.8 [28.1]	91.6 [26.8]	85.1 [25.0]	132.2 [38.8]	126.3 [37.0]	117.5 [34.4]	157.7 [46.2]	154.9 [45.4]	147.0 [43.1]	
	Power	15.2	15.1	14.9	14.9	14.8	14.6	14.6	14.5	14.3	
110 [43.3]	Total BTUH [kW]	172.7 [50.6]	169.6 [49.7]	165.0 [48.3]	159.1 [46.6]	156.3 [45.8]	152.0 [44.5]	149.4 [43.8]	146.7 [43.0]	142.7 [41.8]	
	Sens BTUH [kW]	91.9 [26.9]	87.8 [25.7]	81.6 [23.9]	128.3 [37.6]	122.5 [35.9]	114.0 [33.4]	149.4 [43.8]	146.7 [43.0]	142.7 [41.8]	
	Power	16.3	16.2	16.0	16.1	15.9	15.7	15.8	15.6	15.4	
115 [46.1]	Total BTUH [kW]	163.6 [47.9]	160.6 [47.1]	156.3 [45.8]	150.0 [44.0]	147.3 [43.2]	143.3 [42.0]	140.2 [41.1]	137.7 [40.4]	134.0 [39.3]	
	Sens BTUH [kW]	87.5 [25.6]	83.6 [24.5]	77.7 [22.8]	123.9 [36.3]	118.4 [34.7]	110.1 [32.3]	140.2 [41.1]	137.7 [40.4]	134.0 [39.3]	
	Power	17.5	17.4	17.1	17.2	17.1	16.8	16.8	16.8	16.6	
120 [48.9]	Total BTUH [kW]	153.7 [45.0]	151.0 [44.2]	146.9 [43.0]	140.2 [41.1]	137.7 [40.3]	133.9 [39.2]	130.4 [38.2]	128.1 [37.5]	124.6 [36.5]	
	Sens BTUH [kW]	82.7 [24.2]	79.0 [23.2]	73.5 [21.5]	119.1 [34.9]	113.8 [33.3]	105.8 [31.0]	130.4 [38.2]	128.1 [37.5]	124.6 [36.5]	
	Power	18.7	18.6	18.3	18.4	18.3	18.0	18.2	18	17.8	
125 [51.7]	Total BTUH [kW]	143.1 [41.9]	140.6 [41.2]	136.7 [40.1]	129.6 [38.0]	127.3 [37.3]	123.8 [36.3]	119.8 [35.1]	117.7 [34.5]	114.5 [33.5]	
	Sens BTUH [kW]	77.5 [22.7]	74.1 [21.7]	68.9 [20.2]	113.9 [33.4]	108.9 [31.9]	101.2 [29.7]	119.8 [35.1]	117.7 [34.5]	114.5 [33.5]	
	Power	20.0	19.8	19.6	19.7	19.5	19.3	19.4	19.3	19.0	

DR —Depression ratio
dbE —Entering air dry bulb
wbE—Entering air wet bulb

Total —Total capacity x 1000 BTUH
Sens —Sensible capacity x 1000 BTUH
Power —KW input

NOTES: ① When the entering air dry bulb is other than 80°F [27°C], adjust the sensible capacity from the table by adding [1.10 x CFM x (1 – DR) x (dbE – 80)].

[] Designates Metric Conversions





GROSS SYSTEMS PERFORMANCE DATA—RLRL-H240

ENTERING INDOOR AIR @ 80°F [26.7°C] dbE ①											
wbE		71°F [21.7°C]			67°F [19.4°C]			63°F [17.2°C]			
CFM [L/s]		8113 [3829]	7375 [3481]	6269 [2959]	8113 [3829]	7375 [3481]	6269 [2959]	8113 [3829]	7375 [3481]	6269 [2959]	
DR ①		.11	.09	.06	.11	.09	.06	.11	.09	.06	
OUTDOOR DRY BULB TEMPERATURE [°C]	75 [23.9]	Total BTUH [kW] Sens BTUH [kW] Power	245.4 [71.9] 186.3 [54.6] 16.5	241.0 [70.6] 178.0 [52.2] 16.4	234.4 [68.7] 165.5 [48.5] 16.2	245.4 [71.9] 186.3 [54.6] 16.5	241.0 [70.6] 178.0 [52.2] 16.4	234.4 [68.7] 165.5 [48.5] 16.2	245.4 [71.9] 186.3 [54.6] 16.5	241.0 [70.6] 178.0 [52.2] 16.4	234.4 [68.7] 165.5 [48.5] 16.2
	80 [26.7]	Total BTUH [kW] Sens BTUH [kW] Power	245.4 [71.9] 186.3 [54.6] 16.5	241.0 [70.6] 178.0 [52.2] 16.4	234.4 [68.7] 165.5 [48.5] 16.2	245.4 [71.9] 186.3 [54.6] 16.5	241.0 [70.6] 178.0 [52.2] 16.4	234.4 [68.7] 165.5 [48.5] 16.2	245.4 [71.9] 186.3 [54.6] 16.5	241.0 [70.6] 178.0 [52.2] 16.4	234.4 [68.7] 165.5 [48.5] 16.2
	85 [29.4]	Total BTUH [kW] Sens BTUH [kW] Power	245.4 [71.9] 186.3 [54.6] 16.5	241.0 [70.6] 178.0 [52.2] 16.4	234.4 [68.7] 165.5 [48.5] 16.2	245.4 [71.9] 186.3 [54.6] 16.5	241.0 [70.6] 178.0 [52.2] 16.4	234.4 [68.7] 165.5 [48.5] 16.2	245.4 [71.9] 186.3 [54.6] 16.5	241.0 [70.6] 178.0 [52.2] 16.4	234.4 [68.7] 165.5 [48.5] 16.2
	90 [32.2]	Total BTUH [kW] Sens BTUH [kW] Power	245.4 [71.9] 186.3 [54.6] 16.5	241.0 [70.6] 178.0 [52.2] 16.4	234.4 [68.7] 165.5 [48.5] 16.2	245.4 [71.9] 186.3 [54.6] 16.5	241.0 [70.6] 178.0 [52.2] 16.4	234.4 [68.7] 165.5 [48.5] 16.2	245.4 [71.9] 186.3 [54.6] 16.5	241.0 [70.6] 178.0 [52.2] 16.4	234.4 [68.7] 165.5 [48.5] 16.2
	95 [35]	Total BTUH [kW] Sens BTUH [kW] Power	245.4 [71.9] 186.3 [54.6] 16.5	241.0 [70.6] 178.0 [52.2] 16.4	234.4 [68.7] 165.5 [48.5] 16.2	245.4 [71.9] 186.3 [54.6] 16.5	241.0 [70.6] 178.0 [52.2] 16.4	234.4 [68.7] 165.5 [48.5] 16.2	245.4 [71.9] 186.3 [54.6] 16.5	241.0 [70.6] 178.0 [52.2] 16.4	234.4 [68.7] 165.5 [48.5] 16.2
	100 [37.8]	Total BTUH [kW] Sens BTUH [kW] Power	245.4 [71.9] 186.3 [54.6] 16.5	241.0 [70.6] 178.0 [52.2] 16.4	234.4 [68.7] 165.5 [48.5] 16.2	245.4 [71.9] 186.3 [54.6] 16.5	241.0 [70.6] 178.0 [52.2] 16.4	234.4 [68.7] 165.5 [48.5] 16.2	245.4 [71.9] 186.3 [54.6] 16.5	241.0 [70.6] 178.0 [52.2] 16.4	234.4 [68.7] 165.5 [48.5] 16.2
	105 [40.6]	Total BTUH [kW] Sens BTUH [kW] Power	245.4 [71.9] 186.3 [54.6] 16.5	241.0 [70.6] 178.0 [52.2] 16.4	234.4 [68.7] 165.5 [48.5] 16.2	245.4 [71.9] 186.3 [54.6] 16.5	241.0 [70.6] 178.0 [52.2] 16.4	234.4 [68.7] 165.5 [48.5] 16.2	245.4 [71.9] 186.3 [54.6] 16.5	241.0 [70.6] 178.0 [52.2] 16.4	234.4 [68.7] 165.5 [48.5] 16.2
	110 [43.3]	Total BTUH [kW] Sens BTUH [kW] Power	245.4 [71.9] 186.3 [54.6] 16.5	241.0 [70.6] 178.0 [52.2] 16.4	234.4 [68.7] 165.5 [48.5] 16.2	245.4 [71.9] 186.3 [54.6] 16.5	241.0 [70.6] 178.0 [52.2] 16.4	234.4 [68.7] 165.5 [48.5] 16.2	245.4 [71.9] 186.3 [54.6] 16.5	241.0 [70.6] 178.0 [52.2] 16.4	234.4 [68.7] 165.5 [48.5] 16.2
	115 [46.1]	Total BTUH [kW] Sens BTUH [kW] Power	245.4 [71.9] 186.3 [54.6] 16.5	241.0 [70.6] 178.0 [52.2] 16.4	234.4 [68.7] 165.5 [48.5] 16.2	245.4 [71.9] 186.3 [54.6] 16.5	241.0 [70.6] 178.0 [52.2] 16.4	234.4 [68.7] 165.5 [48.5] 16.2	245.4 [71.9] 186.3 [54.6] 16.5	241.0 [70.6] 178.0 [52.2] 16.4	234.4 [68.7] 165.5 [48.5] 16.2
	120 [48.9]	Total BTUH [kW] Sens BTUH [kW] Power	245.4 [71.9] 186.3 [54.6] 16.5	241.0 [70.6] 178.0 [52.2] 16.4	234.4 [68.7] 165.5 [48.5] 16.2	245.4 [71.9] 186.3 [54.6] 16.5	241.0 [70.6] 178.0 [52.2] 16.4	234.4 [68.7] 165.5 [48.5] 16.2	245.4 [71.9] 186.3 [54.6] 16.5	241.0 [70.6] 178.0 [52.2] 16.4	234.4 [68.7] 165.5 [48.5] 16.2
	125 [51.7]	Total BTUH [kW] Sens BTUH [kW] Power	245.4 [71.9] 186.3 [54.6] 16.5	241.0 [70.6] 178.0 [52.2] 16.4	234.4 [68.7] 165.5 [48.5] 16.2	245.4 [71.9] 186.3 [54.6] 16.5	241.0 [70.6] 178.0 [52.2] 16.4	234.4 [68.7] 165.5 [48.5] 16.2	245.4 [71.9] 186.3 [54.6] 16.5	241.0 [70.6] 178.0 [52.2] 16.4	234.4 [68.7] 165.5 [48.5] 16.2

DR —Depression ratio
dbE —Entering air dry bulb
wbE —Entering air wet bulb

Total —Total capacity x 1000 BTUH
Sens —Sensible capacity x 1000 BTUH
Power —kW input

NOTES: ① When the entering air dry bulb is other than 80°F [27°C], adjust the sensible capacity from the table by adding [1.10 x CFM x (1 – DR) x (dbE – 80)].

[] Designates Metric Conversions





Air

Indoor Airflow Performance
RLRL-H Series

AIRFLOW PERFORMANCE — 15 TON [52.8 kW]—SIDEFLOW

Air Flow CFM [L/s]	Capacity 15 Ton [52.8 kW] Voltage 208/230, 460, 575 — 3 Phase																			
	External Static Pressure—Inches of Water [kPa]																			
	0.1 [0.02]	0.2 [0.05]	0.3 [0.07]	0.4 [0.10]	0.5 [0.12]	0.6 [0.15]	0.7 [0.17]	0.8 [0.20]	0.9 [0.22]	1.0 [0.25]	1.1 [0.27]	1.2 [0.30]	1.3 [0.32]	1.4 [0.35]	1.5 [0.37]	1.6 [0.40]	1.7 [0.42]	1.8 [0.45]	1.9 [0.47]	2.0 [0.50]
4800 [2265]	—	—	—	—	—	—	—	—	—	—	—	—	—	—	—	—	—	—	—	—
5000 [2359]	—	—	—	—	—	—	—	—	—	—	—	—	—	—	—	—	—	—	—	—
5200 [2454]	—	—	—	—	—	—	—	—	—	—	—	—	—	—	—	—	—	—	—	—
5400 [2548]	—	—	—	—	—	—	—	—	—	—	—	—	—	—	—	—	—	—	—	—
5600 [2643]	—	—	—	—	—	—	—	—	—	—	—	—	—	—	—	—	—	—	—	—
5800 [2737]	—	—	—	—	—	—	—	—	—	—	—	—	—	—	—	—	—	—	—	—
6000 [2831]	—	—	—	—	—	—	—	—	—	—	—	—	—	—	—	—	—	—	—	—
6200 [2926]	—	—	—	—	—	—	—	—	—	—	—	—	—	—	—	—	—	—	—	—
6400 [3020]	—	—	—	—	—	—	—	—	—	—	—	—	—	—	—	—	—	—	—	—
6600 [3114]	—	—	—	—	—	—	—	—	—	—	—	—	—	—	—	—	—	—	—	—
6800 [3209]	—	—	—	—	—	—	—	—	—	—	—	—	—	—	—	—	—	—	—	—
7000 [3303]	—	—	—	—	—	—	—	—	—	—	—	—	—	—	—	—	—	—	—	—
7200 [3398]	570	1897	595	2042	619	2185	643	2327	666	689	2602	711	2737	732	2870	753	3000	773	3127	793

NOTE: L-Drive left of bold line, M-Drive right of bold line.

Drive Package	L, R						M, S					
	1	2	3	4	5	6	1	2	3	4	5	6
Motor H.P. [W]	733	701	669	640	605	572	927	903	873	840	808	775
Blower Sheave	BK105H											
Motor Sheave	1VP-56											
Turns Open	840											
RPM	840											

NOTES: 1. Factory sheave settings are shown in bold type.

2. Do not set motor sheave below minimum turns open shown.

3. Re-adjustment of sheave required to achieve rated airflow at AHRI minimum External Static Pressure.

4. Drive data shown is for horizontal airflow with dry coil. Add component resistance (below) to duct resistance to determine total External Static Pressure.



COMPONENT AIR RESISTANCE — 15 TON [52.8 kW]

CFM [L/s]	Resistance — Inches of Water [kPa]													
	4800 [2265]	5000 [2360]	5200 [2454]	5400 [2549]	5600 [2643]	5800 [2737]	6000 [2832]	6200 [2926]	6400 [3020]	6600 [3115]	6800 [3209]	7000 [3304]	7200 [3398]	
Wet Coil	0.03 [0.01]	0.04 [0.01]	0.05 [0.01]	0.06 [0.01]	0.06 [0.01]	0.07 [0.02]	0.08 [0.02]	0.09 [0.02]	0.10 [0.02]	0.10 [0.02]	0.11 [0.03]	0.12 [0.03]	0.13 [0.03]	
Downflow	0.05 [0.01]	0.05 [0.01]	0.05 [0.01]	0.05 [0.01]	0.05 [0.01]	0.05 [0.01]	0.06 [0.01]	0.06 [0.01]	0.06 [0.01]	0.06 [0.01]	0.07 [0.02]	0.08 [0.02]	0.08 [0.02]	
Downflow Economizer R.A. Damper Open	0.09 [0.02]	0.10 [0.02]	0.10 [0.02]	0.11 [0.03]	0.12 [0.03]	0.13 [0.03]	0.13 [0.04]	0.14 [0.03]	0.15 [0.04]	0.16 [0.04]	0.16 [0.04]	0.17 [0.04]	0.18 [0.04]	
Horizontal Economizer R.A. Damper Open	0.00 [0.00]	0.01 [0.00]	0.01 [0.00]	0.02 [0.00]	0.02 [0.00]	0.03 [0.01]	0.03 [0.01]	0.04 [0.01]	0.04 [0.01]	0.05 [0.01]	0.05 [0.01]	0.06 [0.01]	0.06 [0.01]	
Concentric Grill RXRN-AD80 or RXRN-AD81 & Transition RXMC-CJ07	0.21 [0.05]	0.25 [0.06]	0.28 [0.07]	0.32 [0.08]	0.35 [0.09]	0.39 [0.10]	0.43 [0.11]	0.46 [0.11]	0.50 [0.12]	0.54 [0.13]	0.57 [0.14]	0.61 [0.15]	0.64 [0.16]	
Pressure Drop MERV 8	0.068 [0.02]	0.072 [0.02]	0.076 [0.02]	0.08 [0.02]	0.084 [0.02]	0.088 [0.02]	0.092 [0.02]	0.096 [0.02]	0.1 [0.02]	0.104 [0.02]	0.108 [0.03]	0.112 [0.03]	0.116 [0.03]	
Pressure Drop MERV 13	0.009 [0.00]	0.015 [0.00]	0.021 [0.00]	0.028 [0.01]	0.034 [0.01]	0.04 [0.01]	0.046 [0.01]	0.052 [0.01]	0.058 [0.01]	0.065 [0.02]	0.071 [0.02]	0.077 [0.02]	0.083 [0.02]	

NOTE: Add component resistance to duct resistance to determine total external static pressure.

AIRFLOW CORRECTION FACTORS — 15 TON [52.8 kW]

ACTUAL—CFM [L/s]	4800 [2265]	5000 [2360]	5200 [2454]	5400 [2549]	5600 [2643]	5800 [2737]	6000 [2832]	6200 [2926]	6400 [3020]	6600 [3115]	6800 [3209]	7000 [3304]	7200 [3398]
TOTAL MBTUH	0.97	0.97	0.98	0.98	0.99	1.00	1.00	1.01	1.02	1.03	1.03	1.04	1.04
SENSIBLE MBTUH	0.87	0.90	0.92	0.94	0.97	0.99	1.02	1.04	1.06	1.09	1.11	1.14	1.16
POWER kW	0.98	0.98	0.99	0.99	0.99	1.00	1.00	1.00	1.01	1.01	1.01	1.02	1.02

NOTES: Multiply correction factor times gross performance data—resulting sensible capacity cannot exceed total capacity.

[] Designates Metric Conversions

AIRFLOW PERFORMANCE — 20 TON [70.3 kW] — 60 Hz — SIDEFLOW

Model RLRL-C240 Voltage 208/230, 460, 575 — 3 Phase 60 Hz

Air Flow CFM [L/s]	External Static Pressure—Inches of Water [kPa]																																					
	0.1 [0.02] 0.2 [0.05] 0.3 [0.07] 0.4 [0.10] 0.5 [0.12] 0.6 [0.15] 0.7 [0.17] 0.8 [0.20] 0.9 [0.22] 1.0 [0.25] 1.1 [0.27] 1.2 [0.30] 1.3 [0.32] 1.4 [0.35] 1.5 [0.37] 1.6 [0.40] 1.7 [0.42] 1.8 [0.45] 1.9 [0.47] 2.0 [0.50]																																					
	RPM	W	RPM	W	RPM	W	RPM	W	RPM	W	RPM	W	RPM	W	RPM	W	RPM	W	RPM	W	RPM	W	RPM	W	RPM	W	RPM	W	RPM	W	RPM	W	RPM	W	RPM	W	RPM	W
6400 [3020]	—	—	—	—	—	—	—	—	—	—	—	—	—	—	—	—	—	—	—	—	—	—	—	—	—	—	—	—	—	—	—	—	—	—	—	—	—	
6600 [3114]	—	—	—	—	—	—	—	—	—	—	—	—	—	—	—	—	—	—	—	—	—	—	—	—	—	—	—	—	—	—	—	—	—	—	—	—	—	
6800 [3209]	—	—	—	—	—	—	—	—	—	—	—	—	—	—	—	—	—	—	—	—	—	—	—	—	—	—	—	—	—	—	—	—	—	—	—	—	—	
7000 [3303]	—	—	—	—	—	—	—	—	—	—	—	—	—	—	—	—	—	—	—	—	—	—	—	—	—	—	—	—	—	—	—	—	—	—	—	—	—	
7200 [3398]	—	—	—	—	—	—	—	—	—	—	—	—	—	—	—	—	—	—	—	—	—	—	—	—	—	—	—	—	—	—	—	—	—	—	—	—	—	
7400 [3492]	—	—	—	—	—	—	—	—	—	—	—	—	—	—	—	—	—	—	—	—	—	—	—	—	—	—	—	—	—	—	—	—	—	—	—	—	—	
7600 [3586]	682	2566	704	2727	724	2889	745	3051	765	3214	785	3378	805	3543	824	3708	843	3874	862	4041	880	4209	899	4377	917	4546	934	4716	951	4886	968	5057	985	5229	1002	5402		
7800 [3681]	697	2768	718	2931	739	3094	759	3258	779	3423	798	3588	818	3754	837	3921	856	4089	874	4257	892	4426	910	4596	928	4766	945	4937	962	5109	979	5282	995	5456	—	—		
8000 [3775]	712	2979	733	3143	753	3308	773	3473	793	3640	812	3806	831	3974	850	4142	869	4312	888	4481	904	4652	921	4823	939	4995	956	5168	972	5342	989	5516	1005	5691	—	—		
8200 [3869]	728	3199	748	3365	768	3531	787	3698	806	3865	825	4034	844	4203	862	4373	881	4543	898	4715	916	4887	933	5060	950	5233	967	5407	983	5583	999	5758	—	—	—	—		
8400 [3964]	743	3428	763	3595	782	3762	802	3931	820	4100	839	4270	857	4441	875	4612	893	4784	911	4957	928	5131	945	5305	961	5480	978	5656	994	5832	1009	6010	—	—	—	—		
8600 [4058]	758	3665	778	3834	797	4003	816	4173	835	4343	853	4515	871	4687	889	4860	906	5034	923	5208	940	5383	956	5559	973	5735	989	5913	1004	6091	—	—	—	—	—	—		
8800 [4153]	774	3911	793	4081	812	4252	830	4423	849	4596	867	4769	884	4942	902	5117	919	5292	936	5468	952	5644	968	5822	984	6000	1000	6179	—	—	—	—	—	—	—	—		
9000 [4247]	790	4166	808	4338	827	4510	845	4683	863	4857	881	5031	898	5206	915	5382	932	5559	948	5736	964	5915	980	6093	996	6273	—	—	—	—	—	—	—	—	—	—	—	
9200 [4341]	805	4430	824	4603	842	4777	860	4951	877	5127	895	5303	912	5479	929	5657	945	5835	961	6014	977	6194	992	6374	1008	6555	—	—	—	—	—	—	—	—	—	—	—	
9400 [4436]	821	4703	839	4877	857	5052	875	5229	892	5405	909	5583	926	5761	942	5940	959	6120	974	6300	989	6481	1005	6663	—	—	—	—	—	—	—	—	—	—	—	—	—	—
9600 [4530]	837	4984	855	5160	872	5337	890	5514	907	5693	923	5872	940	6052	956	6232	971	6413	987	6595	1002	6778	—	—	—	—	—	—	—	—	—	—	—	—	—	—	—	—

NOTE: L—Drive left of bold line, M—Drive right of bold line, N—Drive right of double line.

Drive Package	M																																					
Motor H.P. [W]	7.5 [5592.7]																																					
Blower Sheave	BK120H																																					
Motor Sheave	1VP-71																																					
Turns Open	1	2	3	4	5	6	1	2	3	4	5	6	1	2	3	4	5	6	1	2	3	4	5	6	1	2	3	4	5	6	1	2	3	4	5	6		
RPM	822	798	771	742	712	684	932	905	878	851	824	797	1007	978	949	921	892	863	—	—	—	—	—	—	—	—	—	—	—	—	—	—	—	—	—	—	—	—

NOTES: 1. Factory sheave settings are shown in bold type.
 2. Do not set motor sheave below minimum turns open shown.
 3. Re-adjustment of sheave required to achieve rated airflow at AHRI minimum External Static Pressure.
 4. Drive data shown is for horizontal airflow with dry coil. Add component resistance (below) to duct resistance to determine total External Static Pressure.

[] Designates Metric Conversions



COMPONENT AIRFLOW RESISTANCE—20 TON [70.3 kW]

Airflow CFM [L/s]	Airflow Correction Factors*			Component Airflow Resistance								
	Total MBH	Sensible MBH	Power kW	Wet Coil	Downflow	Downflow Economizer RA Damper Open	Horizontal Economizer RA Damper Open	Resistance — Inches of Water [kPa]				
								Concentric Grill RXRN-AD80 or RXRN-AD81 & Transition RXMC-CJ07	Concentric Grill RXRN-AD86 & Transition RXMC-CX08	Concentric Grill RXRN-AD88 & Transition RXMC-CL09	Pressure Drop MERV 8	Pressure Drop MERV 13
6400 [3020]	0.97	0.88	0.98	0.01 [.00]	0.06 [.01]	0.15 [.04]	0.04 [.01]	0.50 [.12]	—	—	0.100 [.02]	0.058 [.01]
6600 [3114]	0.97	0.90	0.99	0.02 [.00]	0.06 [.01]	0.16 [.04]	0.05 [.01]	0.54 [.13]	—	—	0.104 [.02]	0.065 [.02]
6800 [3209]	0.98	0.92	0.99	0.03 [.01]	0.07 [.02]	0.16 [.04]	0.05 [.01]	—	—	—	0.108 [.03]	0.071 [.02]
7000 [3303]	0.98	0.94	0.99	0.03 [.01]	0.08 [.02]	0.17 [.04]	0.06 [.01]	—	—	—	0.112 [.03]	0.077 [.02]
7200 [3398]	0.99	0.96	0.99	0.04 [.01]	0.08 [.02]	0.18 [.04]	0.06 [.01]	—	0.38 [.09]	—	0.116 [.03]	0.083 [.02]
7400 [3492]	0.99	0.97	1.00	0.05 [.01]	0.09 [.02]	0.19 [.05]	0.07 [.02]	—	0.41 [.10]	—	0.120 [.03]	0.089 [.02]
7600 [3586]	1.00	0.99	1.00	0.06 [.01]	0.10 [.02]	0.20 [.05]	0.07 [.02]	—	0.44 [.11]	—	0.124 [.03]	0.095 [.02]
7800 [3681]	1.00	1.01	1.00	0.06 [.01]	0.11 [.03]	0.21 [.05]	0.08 [.02]	—	0.47 [.12]	—	0.128 [.03]	0.102 [.02]
8000 [3775]	1.01	1.03	1.00	0.07 [.02]	0.12 [.03]	0.22 [.05]	0.09 [.02]	—	0.50 [.12]	—	0.132 [.03]	0.108 [.03]
8200 [3869]	1.01	1.05	1.01	0.08 [.02]	0.13 [.03]	0.23 [.06]	0.09 [.02]	—	0.53 [.13]	—	0.136 [.03]	0.114 [.03]
8400 [3964]	1.02	1.07	1.01	0.09 [.02]	0.14 [.03]	0.24 [.06]	0.10 [.02]	—	0.56 [.14]	—	0.140 [.03]	0.120 [.03]
8600 [4058]	1.02	1.09	1.01	0.09 [.02]	0.15 [.04]	0.25 [.06]	0.10 [.02]	—	0.59 [.15]	—	0.144 [.03]	0.126 [.03]
8800 [4153]	1.03	1.10	1.01	0.10 [.02]	0.16 [.04]	0.26 [.06]	0.11 [.03]	—	0.62 [.15]	—	0.148 [.04]	0.132 [.03]
9000 [4247]	1.03	1.12	1.01	0.11 [.03]	0.18 [.04]	0.27 [.07]	0.11 [.03]	—	—	—	0.152 [.04]	0.138 [.03]
9200 [4341]	1.03	1.14	1.02	0.12 [.03]	0.19 [.05]	0.28 [.07]	0.12 [.03]	—	—	—	0.156 [.04]	0.145 [.04]
9400 [4436]	1.04	1.16	1.02	0.12 [.03]	0.20 [.05]	0.29 [.07]	0.12 [.03]	—	—	—	0.160 [.04]	0.151 [.04]
9600 [4530]	1.04	1.18	1.02	0.13 [.03]	0.22 [.05]	0.30 [.07]	0.13 [.03]	—	—	—	0.164 [.04]	0.157 [.04]

* Multiply correction factor times gross performance data—resulting sensible capacity cannot exceed total capacity.

[] Designates Metric Conversions



ELECTRICAL DATA – RLRL- SERIES					
		H180CR	H180CS	H180DR	H180DS
Unit Information	Unit Operating Voltage Range	187-253	187-253	414-506	414-506
	Volts	208/230	208/230	460	460
	Minimum Circuit Ampacity	75/75	79/79	38	40
	Minimum Overcurrent Protection Device Size	90/90	90/90	45	45
	Maximum Overcurrent Protection Device Size	100/100	100/100	50	50
Compressor Motor	No.	2	2	2	2
	Volts	200/230	200/230	460	460
	Phase	3	3	3	3
	RPM	3450	3450	3450	3450
	HP, Compressor 1	7 1/2	7 1/2	7 1/2	7 1/2
	Amps (RLA), Comp. 1	25/25	25/25	12.8	12.8
	Amps (LRA), Comp. 1	164/164	164/164	100	100
	HP, Compressor 2	7 1/2	7 1/2	7 1/2	7 1/2
	Amps (RLA), Comp. 2	25/25	25/25	12.8	12.8
Amps (LRA), Comp. 2	164/164	164/164	100	100	
Compressor Motor	No.	3	3	3	3
	Volts	208/230	208/230	460	460
	Phase	1	1	1	1
	HP	1/3	1/3	1/3	1/3
	Amps (FLA, each)	2.4/2.4	2.4/2.4	1.4	1.4
	Amps (LRA, each)	4.7/4.7	4.7/4.7	2.1	2.4
Evaporator Fan	No.	1	1	1	1
	Volts	208/230	208/230	460	460
	Phase	3	3	3	3
	HP	3	5	3	5
	Amps (FLA, each)	11.5/11.5	14.9/14.9	4.6	6.6
	Amps (LRA, each)	74.5/74.5	82.6/82.6	38.1	46.3

ELECTRICAL DATA – RLRL- SERIES

		H240CR	H240CS	H240DR	H240DS
Unit Information	Unit Operating Voltage Range	187-253	187-253	414-506	414-506
	Volts	208/230	208/230	460	460
	Minimum Circuit Ampacity	95/95	103/103	49	52
	Minimum Overcurrent Protection Device Size	110/110	125/125	60	60
	Maximum Overcurrent Protection Device Size	110/110	125/125	60	60
Compressor Motor	No.	2	2	2	2
	Volts	200/230	200/230	460	460
	Phase	3	3	3	3
	RPM	3450	3450	3450	3450
	HP, Compressor 1	10	10	10	10
	Amps (RLA), Comp. 1	30.1/30.1	30.1/30.1	16.7	16.7
	Amps (LRA), Comp. 1	225/225	225/225	114	114
	HP, Compressor 2	7 1/2	7 1/2	7 1/2	7 1/2
	Amps (RLA), Comp. 2	27.6/27.6	27.6/27.6	12.8	12.8
Amps (LRA), Comp. 2	191/191	191/191	100	100	
Compressor Motor	No.	6	6	6	6
	Volts	208/230	208/230	460	460
	Phase	1	1	1	1
	HP	1/3	1/3	1/3	1/3
	Amps (FLA, each)	2.4/2.4	2.4/2.4	1.4	1.4
	Amps (LRA, each)	4.7/4.7	4.7/4.7	2.4	2.4
Evaporator Fan	No.	1	1	1	1
	Volts	208/230	208/230	460	460
	Phase	3	3	3	3
	HP	5	7 1/2	5	7 1/2
	Amps (FLA, each)	14.7/14.7	23.1/23.1	6.6	9.6
	Amps (LRA, each)	82.6/82.6	136/136	46.3	67

208/240 VOLT, THREE PHASE, 60 HZ, AUXILIARY ELECTRIC HEATER KITS CHARACTERISTICS AND APPLICATION																
Separate Power Supply for Both Unit and Heater Kit																
Single Power Supply for Both Unit and Heater Kit																
Model No. RLRL-	Heater Kit				Air Conditioner				Heater Kit				Air Conditioner			
	RXJJ-Heater Kit Nominal kW	No. of Sequence Steps	Rated Heater kW @ 208/240V	Heater kBTU/Hr @ 208/240V	Heater Amps @ 208/240V	Unit Min. Ckt. Ampacity @ 208/240V	Over Current Protective Device Size Min./Max. 208V	Over Current Protective Device Size Min./Max. 240V	Min. Ckt. Ampacity 208/240V	Max. Fuse Size 208/240V	Min. Circuit Ampacity 208/240V	Over Current Protective Device Size Min./Max. 208V	Over Current Protective Device Size Min./Max. 240V			
H180CR	No Heat	—	—	—	—	75/75	90/100	90/100	—	—	75/75	90/100	90/100			
	CE20C	1	14.4/19.2	49.13/65.5	40/46.2	75/75	90/100	90/100	50/58	50/60	75/75	90/100	90/100			
	CE40C	2	28.8/38.3	98.25/130.66	79.9/92.2	115/130	125/125	150/150	100/116	100/125	75/75	90/100	90/100			
	CE60C	2	43.2/57.5	147.38/196.16	119.9/138.3	165/188	175/175	200/200	150/173	150/175	75/75	90/100	90/100			
H240CR	CE75C	2	54/71.9	184.22/245.29	149.8/172.8	202/231	225/225	250/250	188/217	200/225	75/75	90/100	90/100			
	No Heat	—	—	—	—	95/95	110/110	110/110	—	—	95/95	110/110	110/110			
	CE20C	1	14.4/19.2	49.13/65.5	40/46.2	95/95	110/110	110/110	50/58	50/60	95/95	110/110	110/110			
	CE40C	2	28.8/38.3	98.25/130.66	79.9/92.2	119/134	125/125	150/150	100/116	100/125	95/95	110/110	110/110			
H180CS	CE60C	2	43.2/57.5	147.38/196.16	119.9/138.3	169/192	175/175	200/200	150/173	150/175	95/95	110/110	110/110			
	CE75C	2	54/71.9	184.22/245.29	149.8/172.8	206/235	225/225	250/250	188/217	200/225	95/95	110/110	110/110			
	No Heat	—	—	—	—	79/79	90/100	90/100	—	—	79/79	90/100	90/100			
	CE20C	1	14.4/19.2	49.13/65.5	40/46.2	79/79	90/100	90/100	50/58	50/60	79/79	90/100	90/100			
H240CS	CE40C	2	28.8/38.3	98.25/130.66	79.9/92.2	119/134	125/125	150/150	100/116	100/125	79/79	90/100	90/100			
	CE60C	2	43.2/57.5	147.38/196.16	119.9/138.3	169/192	175/175	200/200	150/173	150/175	79/79	90/100	90/100			
	CE75C	2	54/71.9	184.22/245.29	149.8/172.8	206/235	225/225	250/250	188/217	200/225	79/79	90/100	90/100			
	No Heat	—	—	—	—	103/103	125/125	125/125	—	—	103/103	125/125	125/125			
H240CS	CE20C	1	14.4/19.2	49.13/65.5	40/46.2	103/103	125/125	125/125	50/58	50/60	103/103	125/125	125/125			
	CE40C	2	28.8/38.3	98.25/130.66	79.9/92.2	129/145	150/150	150/150	100/116	100/125	103/103	125/125	125/125			
	CE60C	2	43.2/57.5	147.38/196.16	119.9/138.3	179/202	200/200	225/225	150/173	150/175	103/103	125/125	125/125			
	CE75C	2	54/71.9	184.22/245.29	149.8/172.8	217/245	225/225	250/250	188/217	200/225	103/103	125/125	125/125			

480 VOLT, THREE PHASE, 60 HZ, AUXILIARY ELECTRIC HEATER KITS CHARACTERISTICS AND APPLICATION														
Separate Power Supply for Both Unit and Heater Kit														
Single Power Supply for Both Unit and Heater Kit							Air Conditioner							
Model No. RLRL-	RXJJ-Heater Kit Nominal kW	No. of Sequence Steps	Rated Heater kW @ 480V	Heater kBTU/Hr @ 480V	Heater Amps @ 480V	Unit Min. Ckt. Ampacity @ 480V	Over Current Protective Device Size		Heater Kit		Air Conditioner		Over Current Protective Device Size Min./Max. 480V	
							Min./Max. 480V	Min./Max. 480V	Min. Ckt. Ampacity 480V	Max. Fuse Size 480V	Min. Circuit Ampacity 480V	Min./Max. 480V		
H180DR	No Heat	—	—	—	—	38	45/50	—	—	—	—	38	45/50	—
	CE20D	1	19.2	65.5	23.1	38	45/50	—	29	30	38/0	38/0	45/50	0/0
	CE40D	2	38.4	131	46.2	64	70/70	—	58	60	38/0	38/0	45/50	0/0
	CE60D	2	57.6	196.5	69.3	93	100/100	—	87	90	38/0	38/0	45/50	0/0
H240DR	CE75D	2	72	245.63	86.6	114	125/125	—	109	110	38/0	38/0	45/50	0/0
	No Heat	—	—	—	—	49	60/60	—	—	—	49	60/60	60/60	—
	CE20D	1	19.2	65.5	23.1	49	60/60	—	29	30	49/0	49/0	60/60	0/0
	CE40D	2	38.4	131	46.2	67	70/70	—	58	60	49/0	49/0	60/60	0/0
H180DS	CE60D	2	57.6	196.5	69.3	95	100/100	—	87	90	49/0	49/0	60/60	0/0
	CE75D	2	72	245.63	86.6	117	125/125	—	109	110	49/0	49/0	60/60	0/0
	No Heat	—	—	—	—	40	45/50	—	—	—	40	45/50	45/50	—
	CE20D	1	19.2	65.5	23.1	40	45/50	—	29	30	40/0	40/0	45/50	0/0
H240DS	CE40D	2	38.4	131	46.2	67	70/70	—	58	60	40/0	40/0	45/50	0/0
	CE60D	2	57.6	196.5	69.3	95	100/100	—	87	90	40/0	40/0	45/50	0/0
	CE75D	2	72	245.63	86.6	117	125/125	—	109	110	40/0	40/0	45/50	0/0
	No Heat	—	—	—	—	52	60/60	—	—	—	52	60/60	60/60	—
H240DS	CE20D	1	19.2	65.5	23.1	52	60/60	—	29	30	52/0	52/0	60/60	0/0
	CE40D	2	38.4	131	46.2	70	70/70	—	58	60	52/0	52/0	60/60	0/0
	CE60D	2	57.6	196.5	69.3	99	100/100	—	87	90	52/0	52/0	60/60	0/0
	CE75D	2	72	245.63	86.6	121	125/125	—	109	110	52/0	52/0	60/60	0/0

15 TON

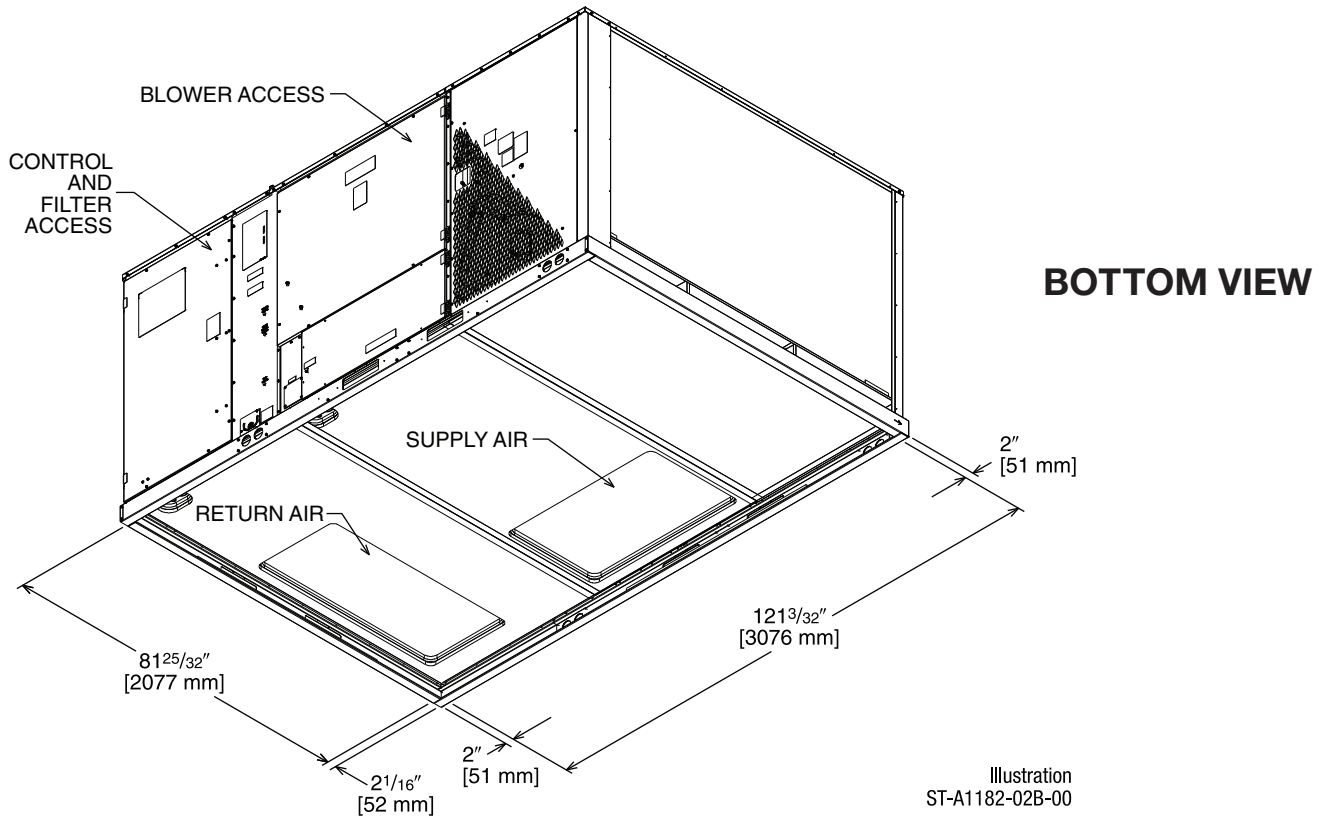
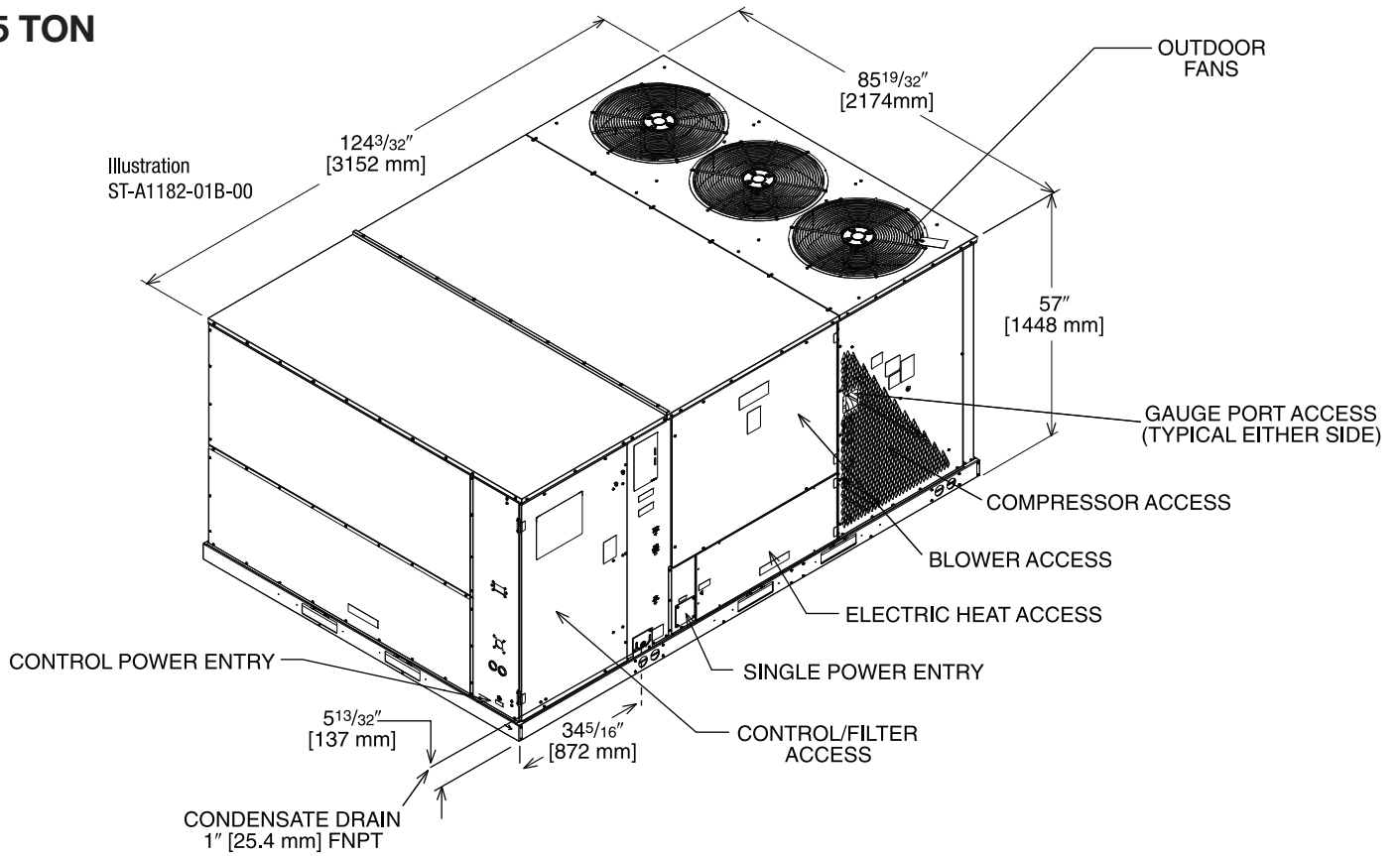

[] Designates Metric Conversions

15 TON

SUPPLY AND RETURN DIMENSIONS FOR HORIZONTAL APPLICATIONS

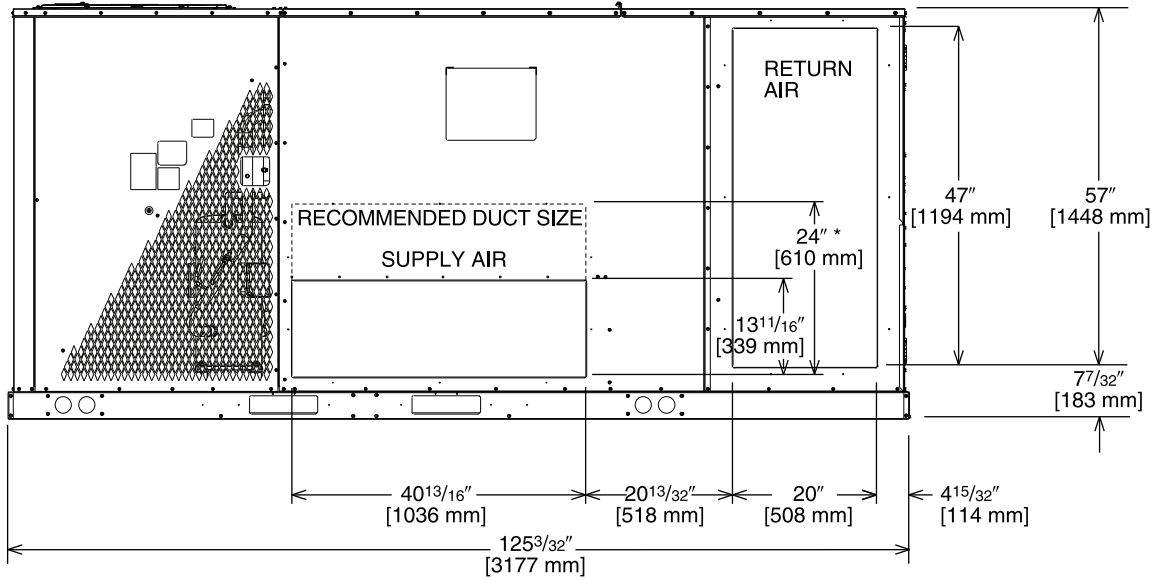

Illustration
ST-A1182-08B-00

* RECOMMENDED DUCT SIZE

DUCT SIDE VIEW (REAR)

SUPPLY AND RETURN DIMENSIONS FOR DOWNFLOW APPLICATIONS

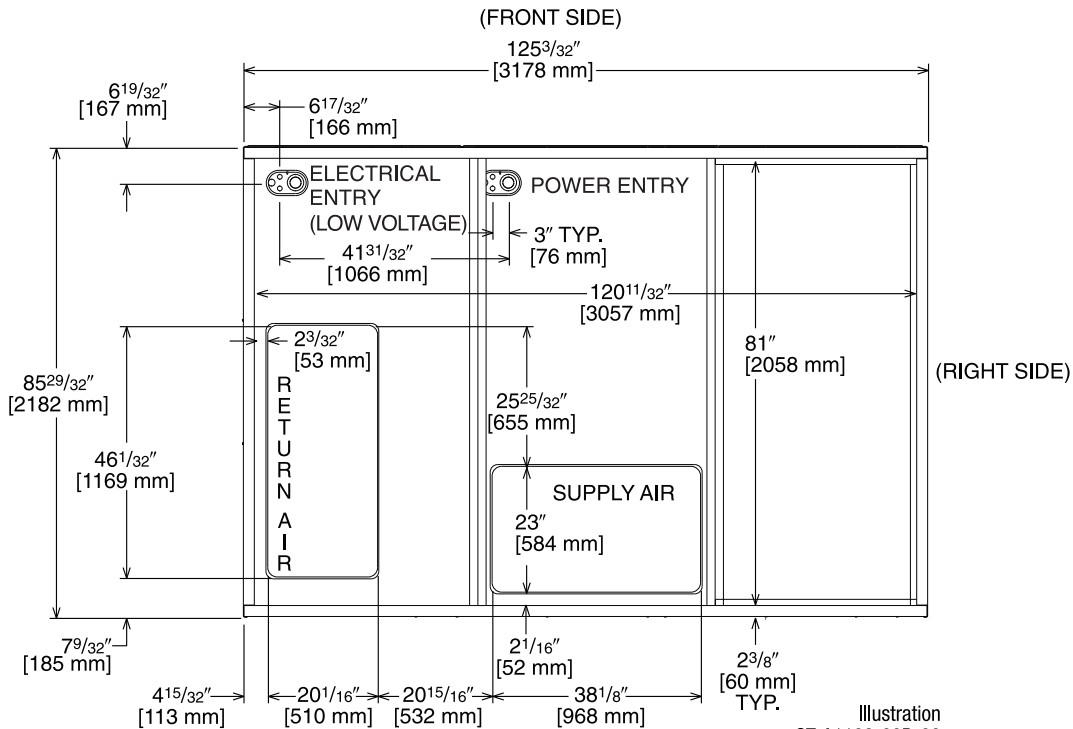
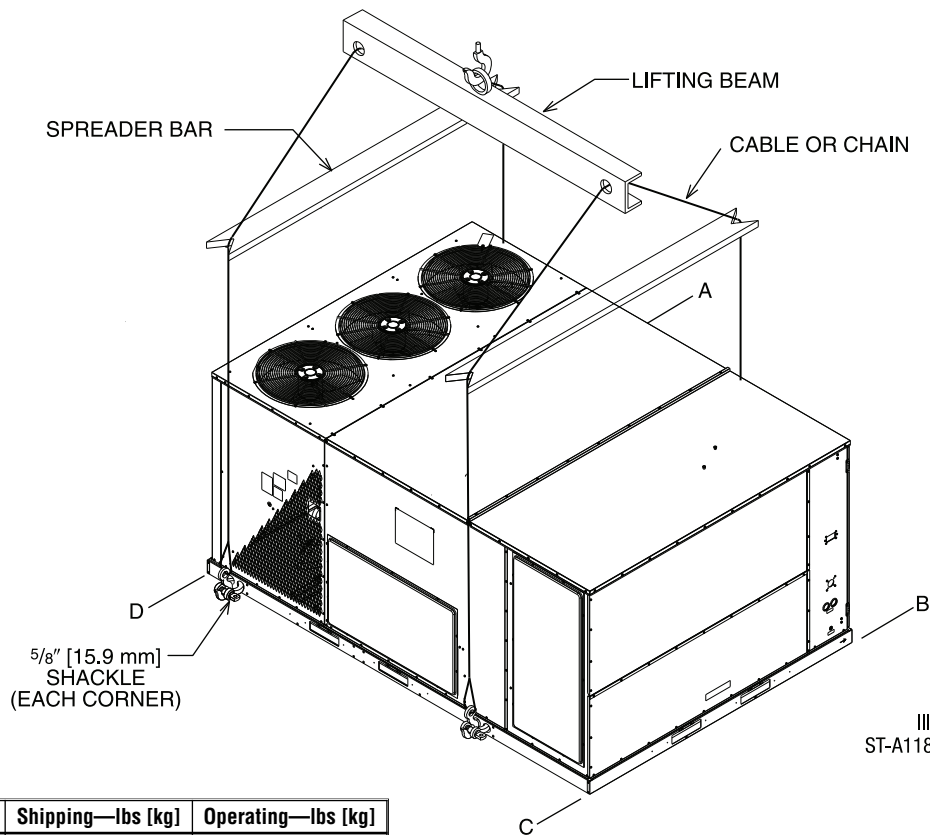
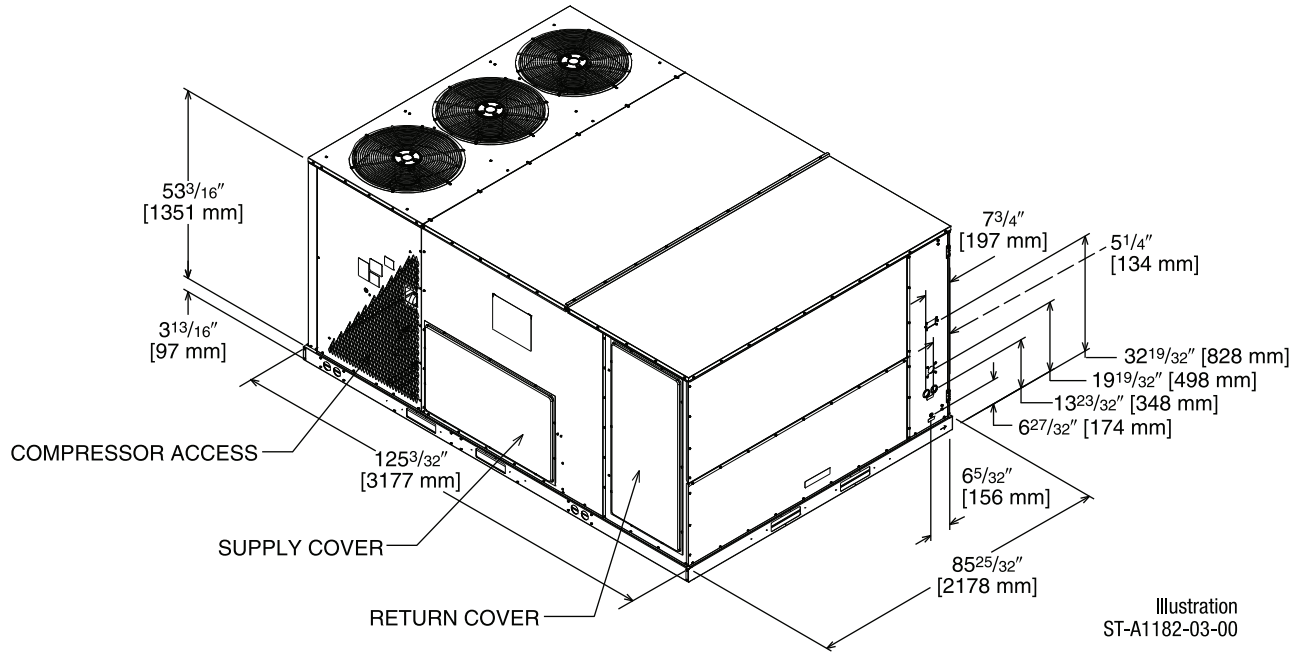

Illustration
ST-A1182-09B-00

BOTTOM VIEW

[] Designates Metric Conversions

UNIT DIMENSIONS SELF-CONTAINED AIR CONDITIONER 15 TON



WEIGHTS

Accessory	Shipping—lbs [kg]	Operating—lbs [kg]
Downflow Economizer	277 [125.6]	168 [76.2]
Horizontal Economizer	333 [151.0]	301 [136.5]
Power Exhaust	119 [54.0]	59 [26.8]
Manual Fresh Air Damper*	61 [27.7]	52 [23.6]
Motor Kit for Fresh Air Damper*	42 [19.1]	35 [15.9]
Roofcurb, 14"	184 [83.5]	176 [79.8]
Hail Guard	50 [22.7]	45 [20.4]

Corner Weights by Percentage			
A	B	C	D
32%	27%	16%	24%

*Note: Corner weights measured at base of unit.

[] Designates Metric Conversions

NOTES: *Motorized Kit and Manual Fresh Air Damper must be combined for a complete Motorized Outside Air Damper Selection.

20 TON

Illustration
ST-A1125-01B

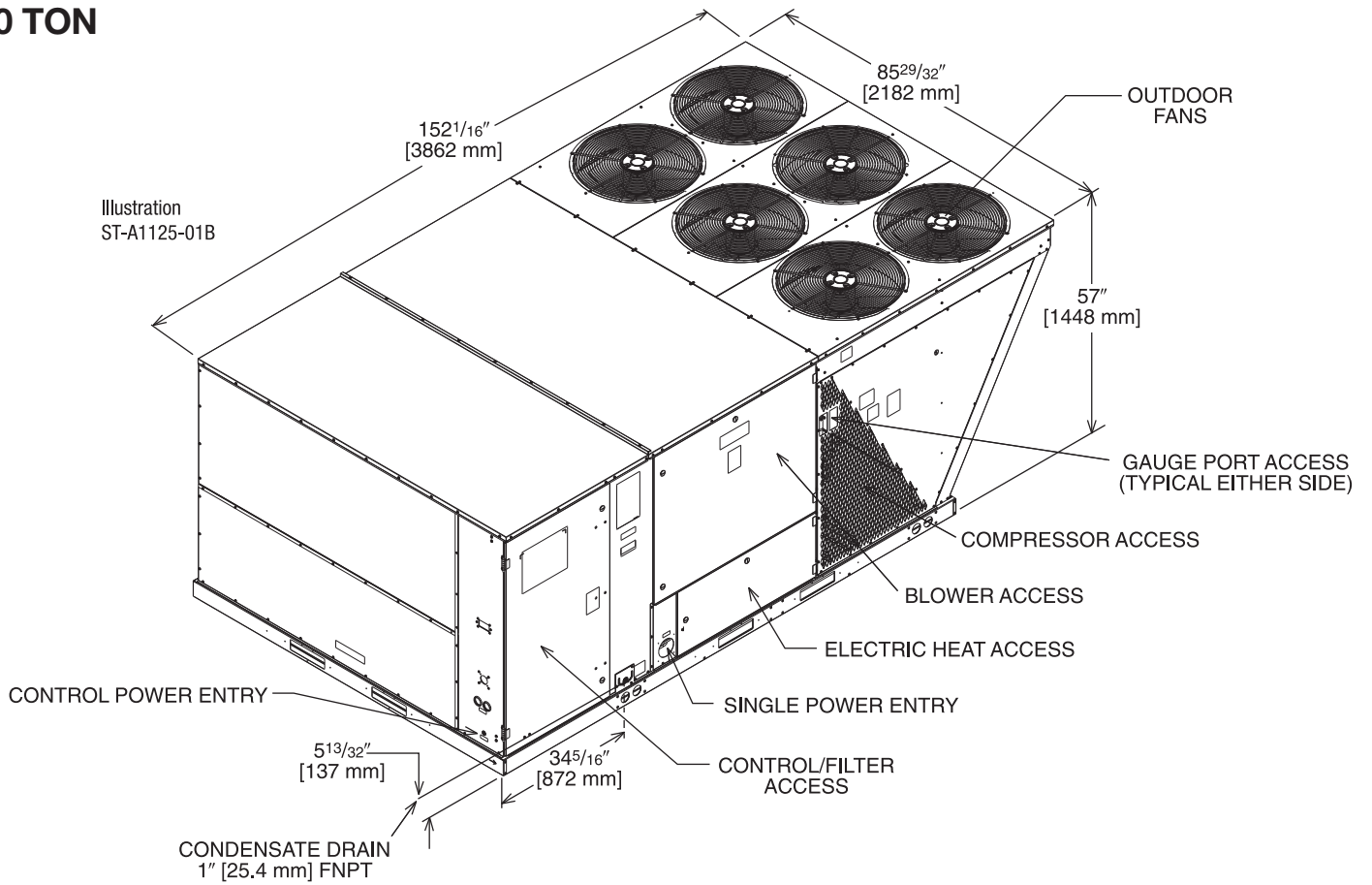

BOTTOM VIEW

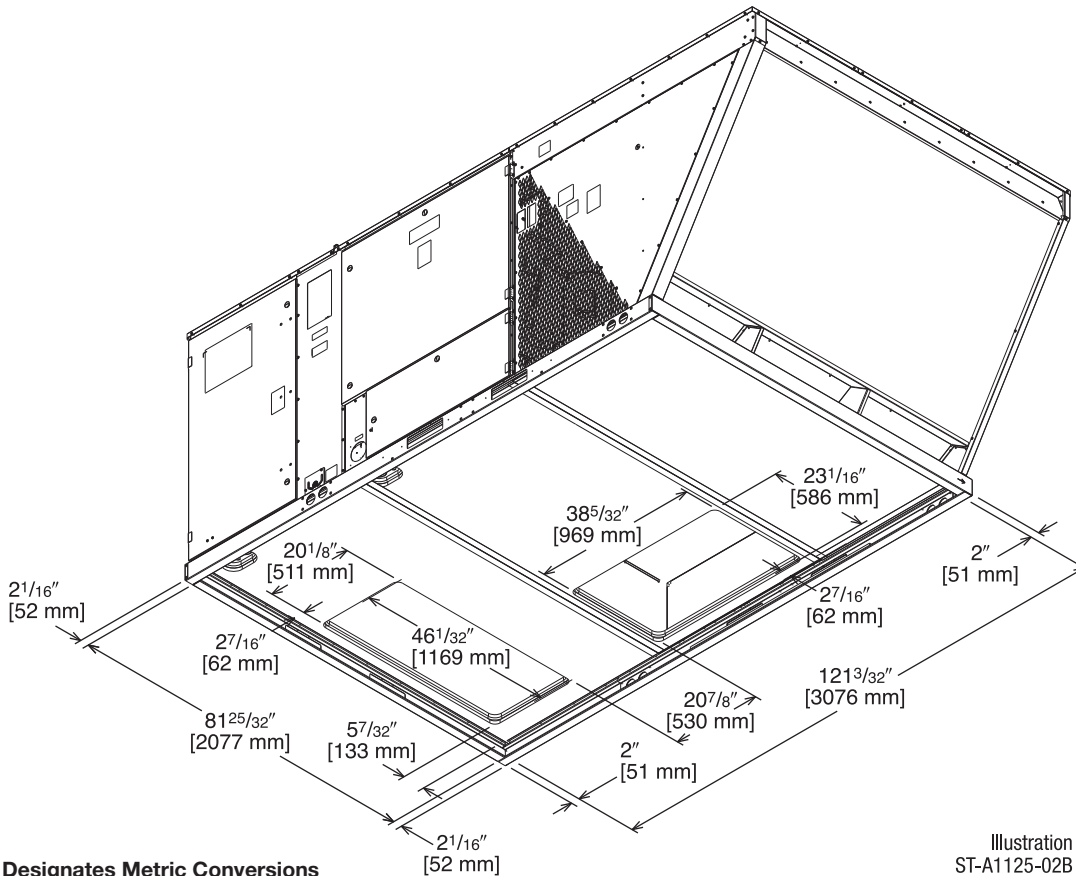
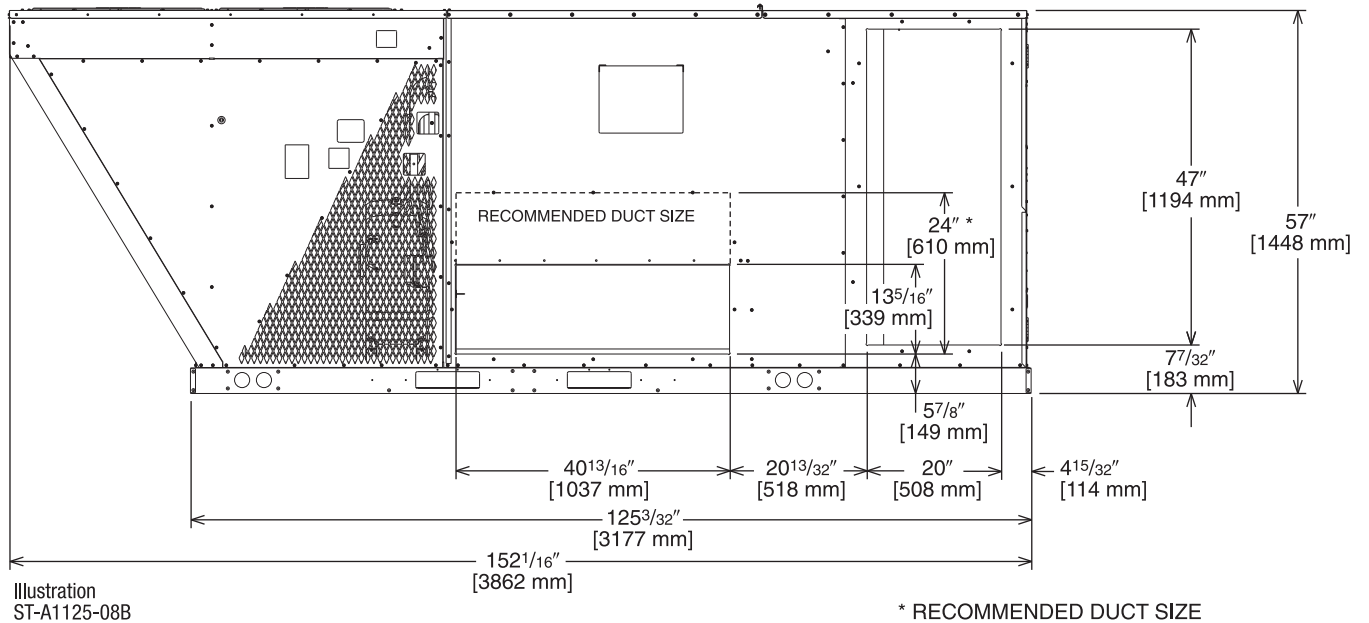

Illustration
ST-A1125-02B

[] Designates Metric Conversions

20 TON

SUPPLY AND RETURN DIMENSIONS FOR HORIZONTAL APPLICATIONS



DUCT SIDE VIEW (REAR)

SUPPLY AND RETURN DIMENSIONS FOR DOWNFLOW APPLICATIONS

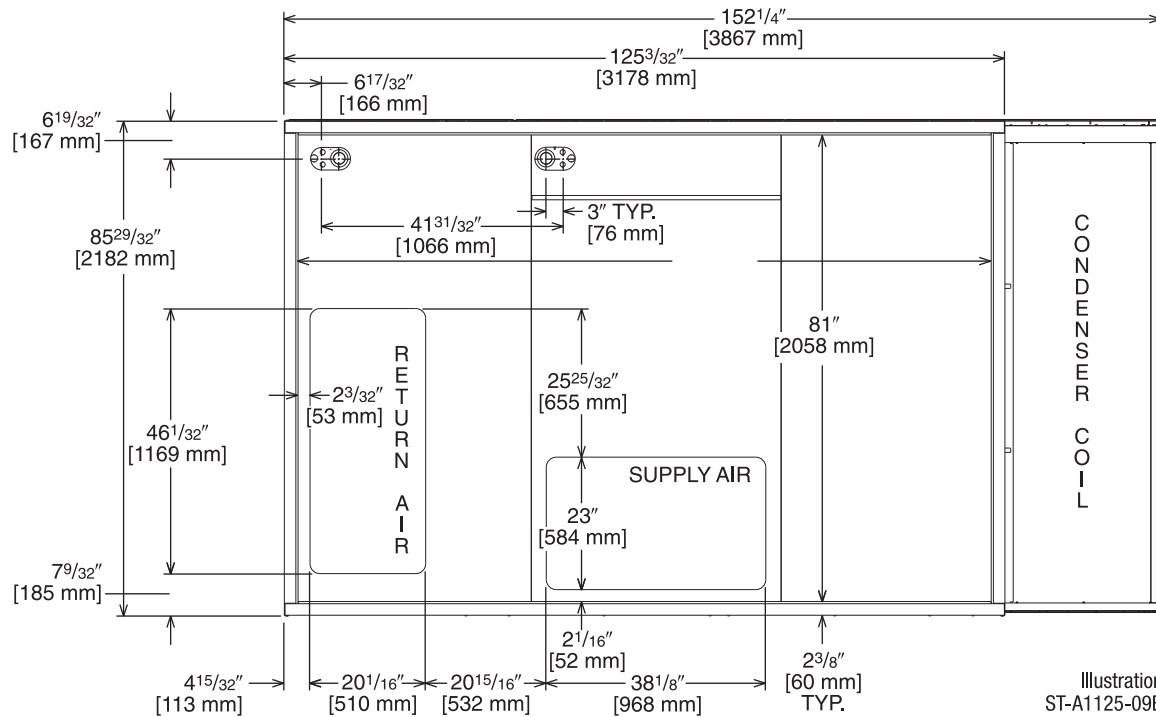

BOTTOM VIEW

[] Designates Metric Conversions

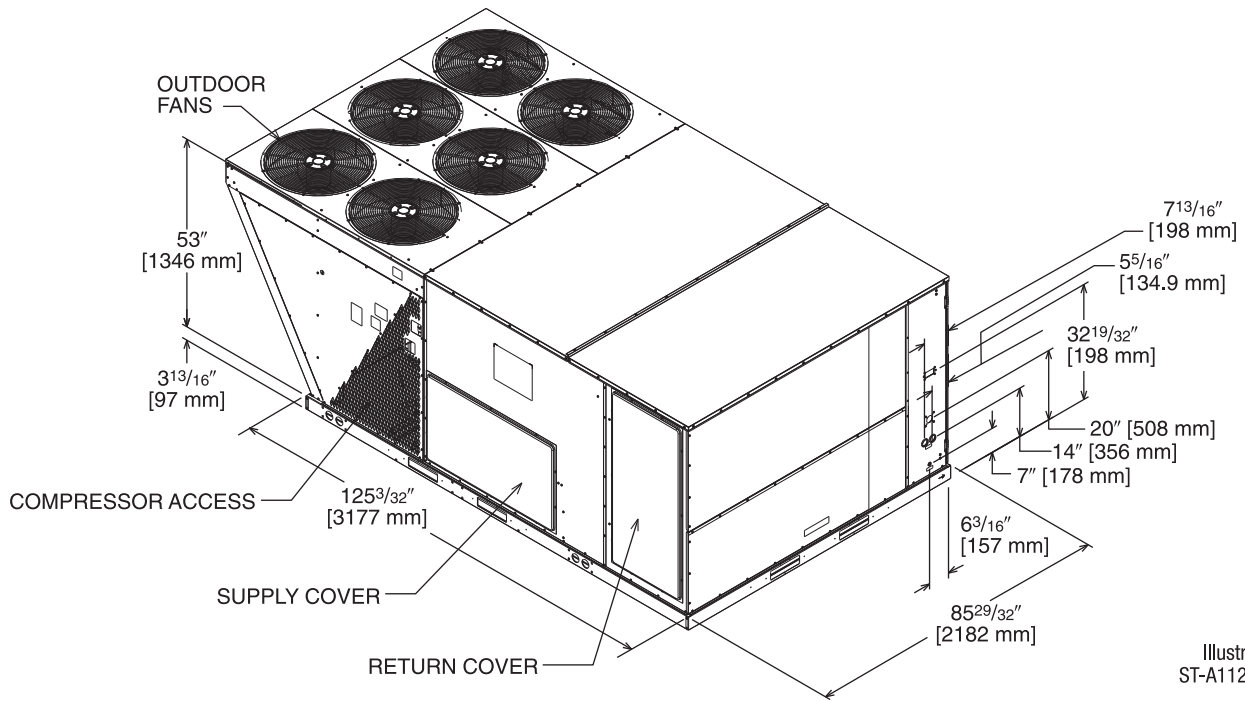
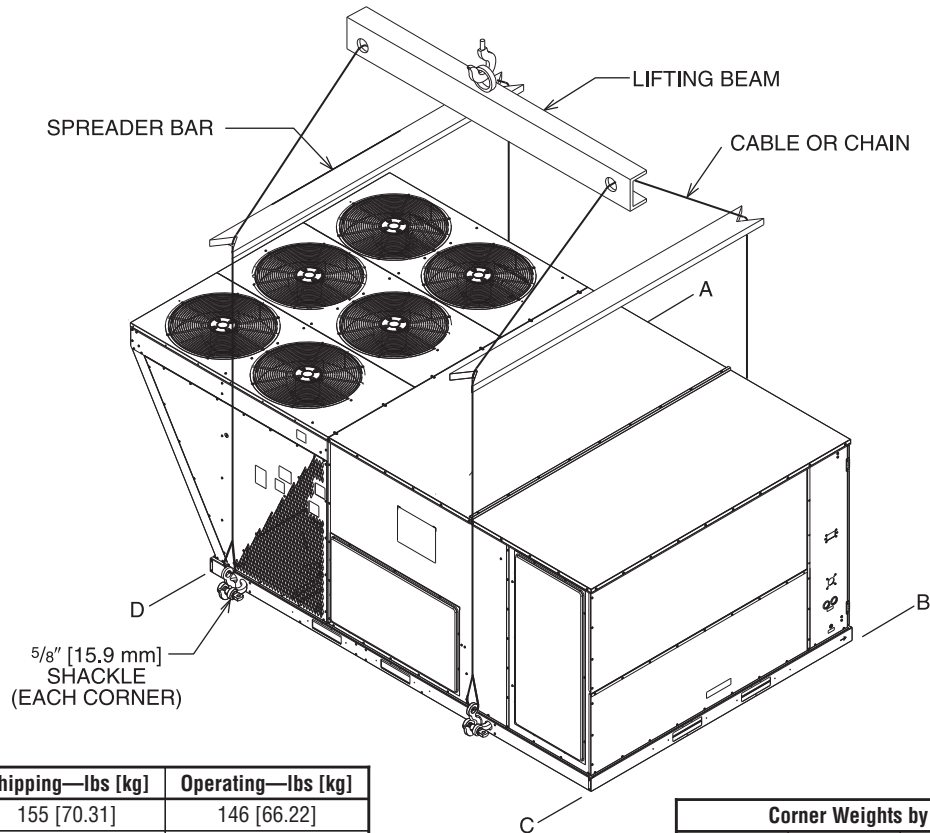

Illustration
ST-A1125-03



WEIGHTS

Accessory	Shipping—lbs [kg]	Operating—lbs [kg]
Economizer—Downflow	155 [70.31]	146 [66.22]
Economizer—Horizontal	165 [74.84]	155 [70.31]
Power Exhaust	44 [19.96]	42 [19.05]
Fresh Air Damper (Manual)	51 [23.13]	40 [18.14]
Fresh Air Damper (Motorized)	46 [20.87]	35 [15.88]
Roof Curb 14"	170 [77.11]	164 [74.39]

Corner Weights by Percentage			
A	B	C	D
32%	27%	16%	24%

*Note: Corner weights measured at base of unit.

[] Designates Metric Conversions

SLAB INSTALLATION

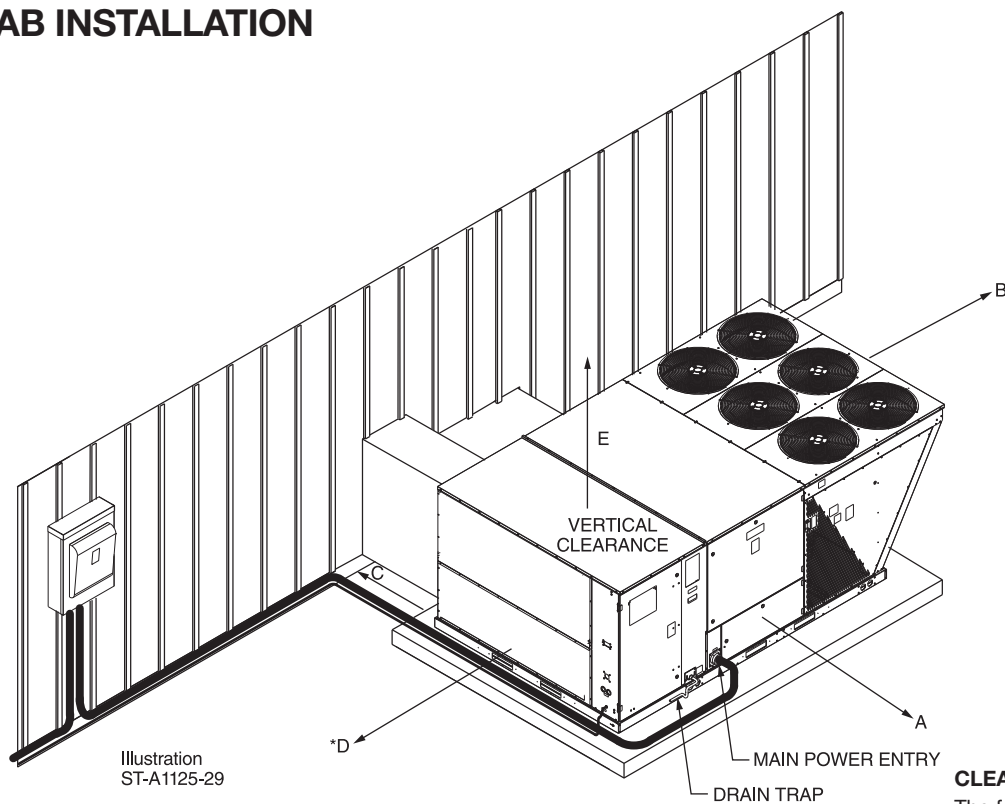

Illustration
ST-A1125-29

CLEARANCES

The following minimum clearances are recommended for proper unit performance and serviceability.

Recommended Clearance In. [mm]	Location
80 [2032]	A - Front
18 [457]	B - Condenser Coil
18 [457]	+C - Duct Side
18 [457]	*D - Evaporator End
60 [1524]	E - Above
*Without Economizer 18" [457 mm]. With Economizer 48" [1219 mm]. +Without Horizontal Economizer 18" [457 mm]. With Horizontal Economizer 42" [1067 mm].	

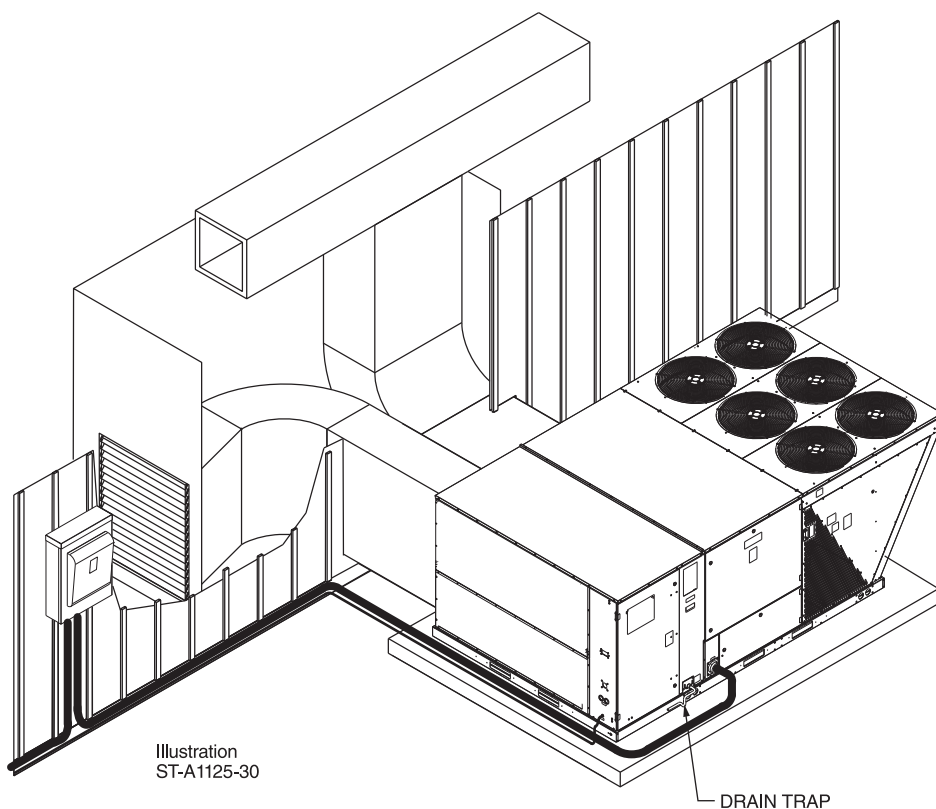

Illustration
ST-A1125-30

[] Designates Metric Conversions

FIELD INSTALLED ACCESSORY EQUIPMENT–SELF CONTAINED AIR CONDITIONER

Accessory	Model Number	Shipping Weight Lbs. [kg]	Installed Weight Lbs. [kg]	Factory Installation Available?
Electric Heaters	RXJJ-CE20 (C, D, Y)	41 [18.6]	31 [14.1]	Yes
	RXJJ-CE40 (C, D, Y)	44 [20.0]	34 [15.4]	Yes
	RXJJ-CE60 (C, D, Y)	45 [20.4]	35 [15.9]	Yes
	RXJJ-CE75 (C, D, Y)	46 [20.8]	36 [16.3]	Yes
Downflow Economizer w/Single Enthalpy (DDC)	AXRD-01RMDCM3	277 [125.6]	168 [76.2]	Yes
Downflow Economizer w/Smoke Detector (DDC)	AXRD-01RMDDM3	280 [127.0]	171 [77.6]	Yes
Dual Enthalpy Kit	RXR-04	1 [.5]	.5 [0.2]	No
Horizontal Economizer w/Single Enthalpy (DDC)	AXRD-01RMHCM3	333 [151.0]	301 [36.5]	No
Carbon Dioxide Sensor (Wall Mount)	RXR-AR02	3 [1.4]	2 [1.0]	No
Power Exhaust (208/230V)	RXR-BGF05C	119 [54.0]	59 [26.8]	No
Power Exhaust (460V)	RXR-BGF05D	119 [54.0]	59 [26.8]	No
Manual Fresh Air Damper*	AXRF-KFA1	61 [27.7]	52 [23.6]	No
Motorized Kit for Manual Fresh Air Damper*	RXR-AW03	42 [19.1]	35 [15.9]	No
Modulating Motor Kit w/position feedback for AXRF-KFA1	RXR-AW05	45 [20.4]	38 [17.2]	No
Roofcurb, 14"	RXKG-CBH14	184 [83.5]	176 [79.8]	No
Roofcurb Adapter to RXRK-E56	RXR-CJCE56	465 [210.9]	415 [88.2]	No
Roofcurb Adapter to RXKG-CAF14	RXR-CJCF14	555 [251.7]	505 [29.1]	No
Concentric Diffuser (Step-Down, 18" x 36")	RXR-AD81	310 [140.6]	157 [71.2]	No
Concentric Diffuser (Step-Down, 24" x 48")	RXR-AD86	367 [166.5]	212 [96.2]	No
Concentric Diffuser (Step-Down, 28" x 60")	RXR-AD88	410 [186.0]	370 [67.8]	No
Concentric Diffuser (Flush, 18" x 36")	RXR-AD80	213 [96.6]	115 [52.2]	No
Downflow Transition (Rect. to Rect., 18" x 36")	RXMC-CJ07	81 [36.7]	74 [33.6]	No
Downflow Transition (Rect. to Rect., 24" x 48")	RXMC-CK08	81 [36.7]	74 [33.6]	No
Downflow Transition (Rect. to Rect., 28" x 60")	RXMC-CL09	81 [36.7]	74 [33.6]	No
Low-Ambient Control Kit (1 Per Compressor)	RXR-C02	3 [1.4]	2 [0.9]	Yes
Unwired Convenience Outlet	RXR-AN01	2 [0.9]	1.5 [.7]	Yes
Unfused Service Disconnect+	RXR-AP01	10 [4.5]	9 [4.1]	Yes
Comfort Alert (1 per Compressor)	RXR-AZ01	3 [1.4]	2 [0.9]	Yes
BACnet Communication Card	RXR-AY01	1 [0.5]	1 [0.5]	No
LonWorks Communication Card	RXR-AY02	1 [0.5]	1 [0.5]	No
Room Humidity Sensor	RHC-ZNS4	1 [0.5]+	1 [0.5]+	No*
Room Temperature and Relative Humidity Sensor	RHC-ZNS5	1 [0.5]+	1 [0.5]+	No*
Hail Guard Louvers	AXR-AAD01L	55 [24.8]	45 [20.3]	Yes
MERV 8 Filter	RXMF-M08A22520	2 [0.9]	1 [0.45]	No
MERV 13 Filter	RXMF-M13A22520	2 [0.9]	1 [0.45]	No

*Motorized Kit and Manual Fresh Air Damper must be combined for a complete Motorized Outside Air Damper Selection.

+Do not use on or RKNL-C 300C voltage models.

[] Designates Metric Conversions

FLUSH MOUNT ROOM TEMPERATURE SENSORS FOR NETWORKED DDC APPLICATIONS



ROOM TEMPERATURE SENSOR RHC-ZNS1 with TIMED OVERRIDE BUTTON

10k Ω room temperature sensor transmits room temperature to DDC system. Timed override button allows tenant to change from unoccupied temperature setpoint to occupied temperature setpoint for a preset time.



ROOM TEMPERATURE SENSOR RHC-ZNS2 with TIMED OVERRIDE BUTTON and STATUS INDICATOR

10k Ω room temperature sensor transmits room temperature to DDC system. Timed override button allows tenant to change from unoccupied temperature setpoint to occupied temperature setpoint for a preset time. Status Indicator Light transmits ALARM flash code to occupied space.



ROOM TEMPERATURE SENSOR RHC-ZNS3 with SETPOINT ADJUSTMENT and TIMED OVERRIDE BUTTON

10k Ω room temperature sensor with setpoint adjustment transmits room temperature to DDC system along with desired occupied room temperature setpoint. Timed override button allows tenant to change from unoccupied temperature setpoint to occupied temperature setpoint for a preset time.

COMMUNICATION CARDS

Field Installed



BACnet® COMMUNICATION CARD RXXR-AY01

The field installed BACnet® Communication Card allows the RTU-C unit controller to communicate with a third party building management system that supports the BACnet Application Specific Controller device profile. The BACnet® Communication Module plugs onto the unit RTU-C controller and allows communication between the RTU-C and the BACnet MSTP network.



LonWorks® COMMUNICATION CARD RXXR-AY02

The field installed LonWorks® Communication Card allows the RTU-C unit controller to communicate with a third party building management system that supports the LonMark Space Comfort Controller (SCC) functional profile or LonMark Discharge Air Controller (DAC) functional profile. The LonMark Communication Module plugs onto the RTU-C controller and allows communication between the RTU-C and a LonWorks Network.

ECONOMIZERS—DOWNFLOW ONLY

Field Installed

- AXRD-01RMDCM3—Single Enthalpy (Outdoor) with DDC**
- AXRD-01RMDDM3—Single Enthalpy (Outdoor) w/Smoke Detector and DDC**
- RXXR-AR02—Optional Wall-Mounted CO₂ Sensor**
- RXXR-AV04—Dual Enthalpy Upgrade Kit**

- Features **Honeywell** Controls
- Available Factory Installed or Field Accessory
- Gear Driven Direct Drive Actuator
- Fully Modulating (0-100%)
- Low Leakage Dampers
- Slip-In Design for Easy Installation
- Plug-In Polarized 12-pin & 4-pin Electrical Connections
- Pre-Configured—No Field Adjustments Necessary
- Standard Barometric Relief Damper
- Single Enthalpy with Dual Enthalpy Upgrade Kit Available
- CO₂ Input Sensor Available
- Field Assembled Hood Ships with Economizer
- Economizer Ships Complete for Downflow Duct Application
- Optional Remote Minimum Position Potentiometer (270 ohm) (Honeywell #S963B1136) is Available from Prostock
- Field Installed Power Exhaust Available
- If connected to a Building Automation System (BAS), all economizer functions can be viewed on the (BAS)

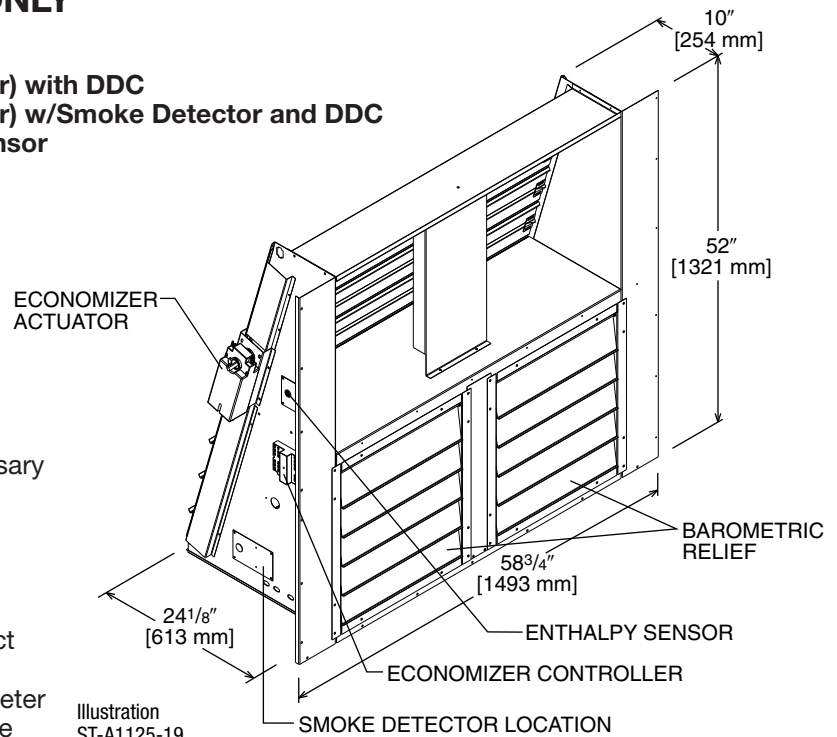

Illustration
ST-A1125-19

TOLERANCE ± .125

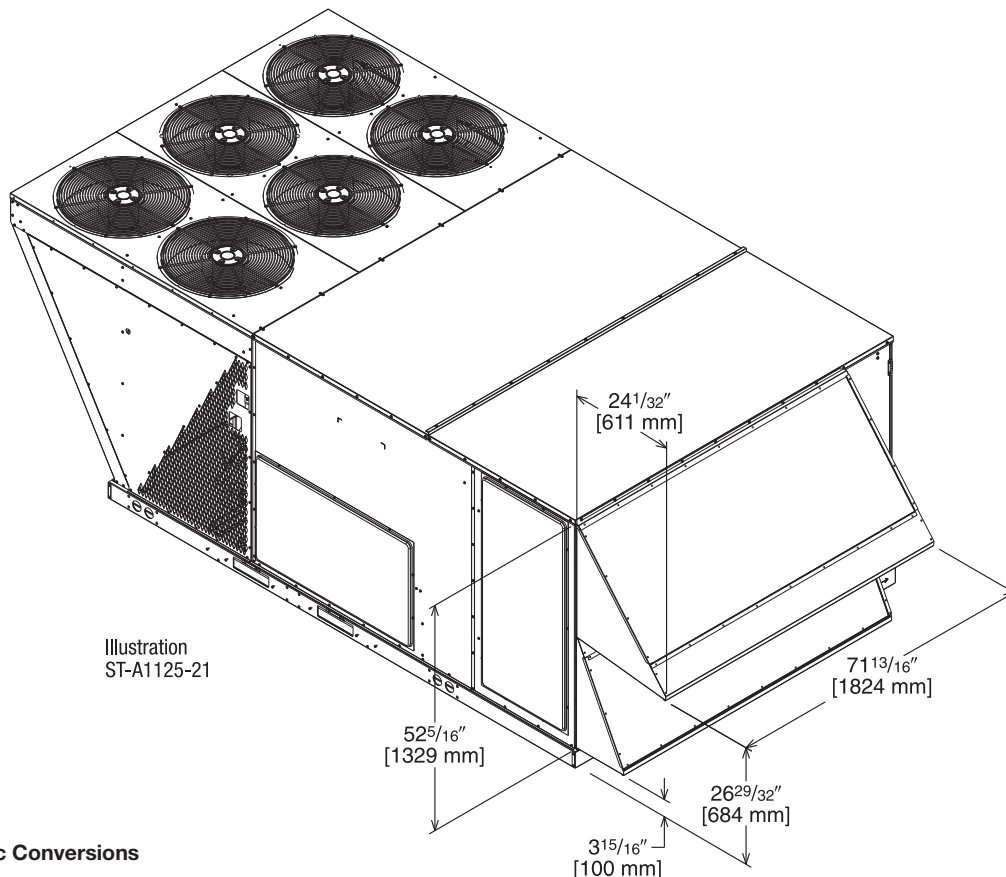

Illustration
ST-A1125-21

[] Designates Metric Conversions

ECONOMIZER FOR HORIZONTAL DUCT INSTALLATION

Field Installed Only

AXRD01RMHCM3—Single Enthalpy (Outdoor) with DDC
RXXR-AV04—Dual Enthalpy Upgrade Kit
RXXR-AR02—Optional Wall-Mounted CO₂ Sensor

- Features **Honeywell** Controls
- Available as a Field Installed Accessory Only
- Gear Driven Direct Drive Actuator
- Fully Modulating (0-100%)
- Low Leakage Dampers
- Slip-In Design for Easy Installation
- Plug-In Polarized 12-pin and 4-pin Electrical Connections
- Pre-Configured—No Field Adjustments Necessary
- Standard Barometric Relief Damper
- Single Enthalpy with Dual Enthalpy Upgrade Kit Available
- CO₂ Input Sensor Available
- Field Assembled Hood Ships with Economizer
- Economizer Ships Complete for Horizontal Duct Application
- Optional Remote Minimum Position Potentiometer (270 ohm) (Honeywell #S963B1136) is available from Prostock
- Field Installed Power Exhaust Available
- If connected to a Building Automation System (BAS), all economizer functions can be viewed on the (BAS) or 16 x 2 LCD screen
- If connected to thermostat, all economizer functions can be viewed on 16 x 2 character LCD screen

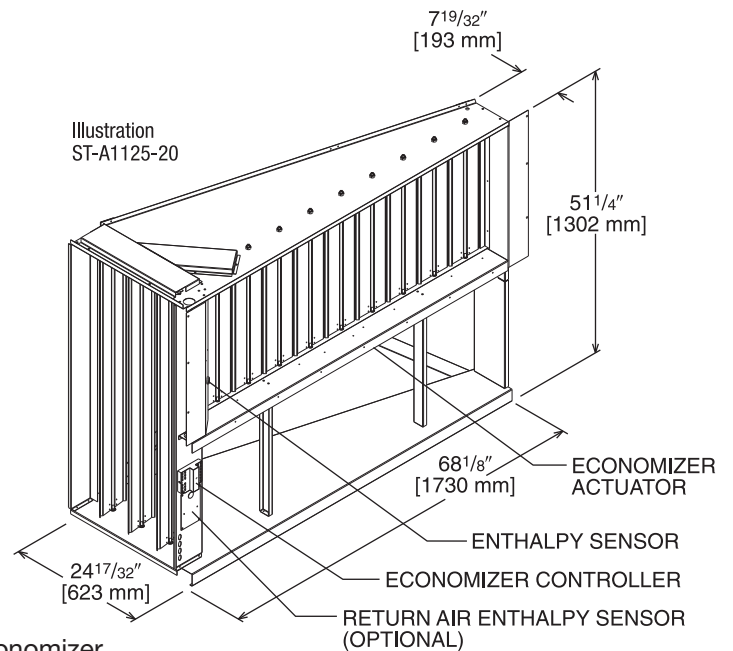

TOLERANCE ± .125

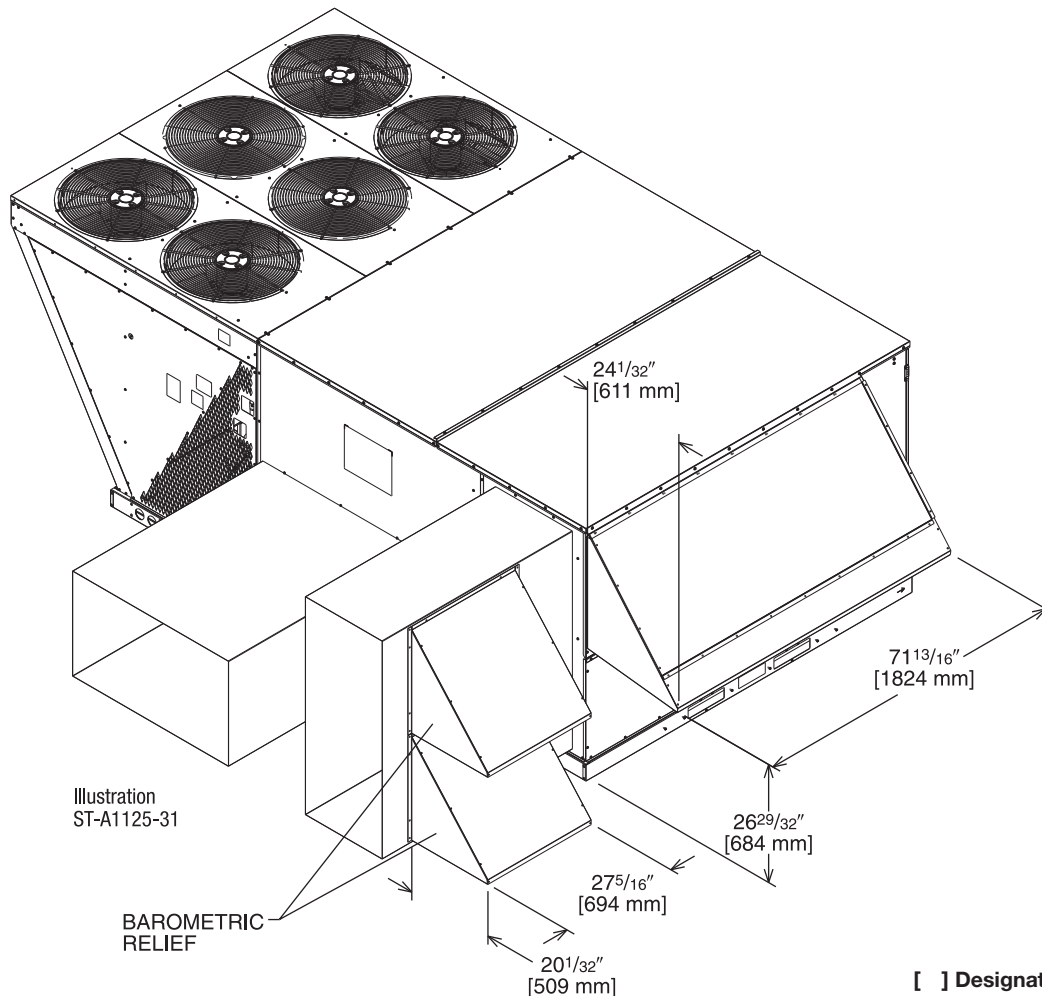

[] Designates Metric Conversions

INTEGRAL POWER EXHAUST KIT FOR AXRD-PMCM3 OR SMCM3 ECONOMIZERS

RXRX-BGF05 (C, D, or Y*)

*Voltage Code

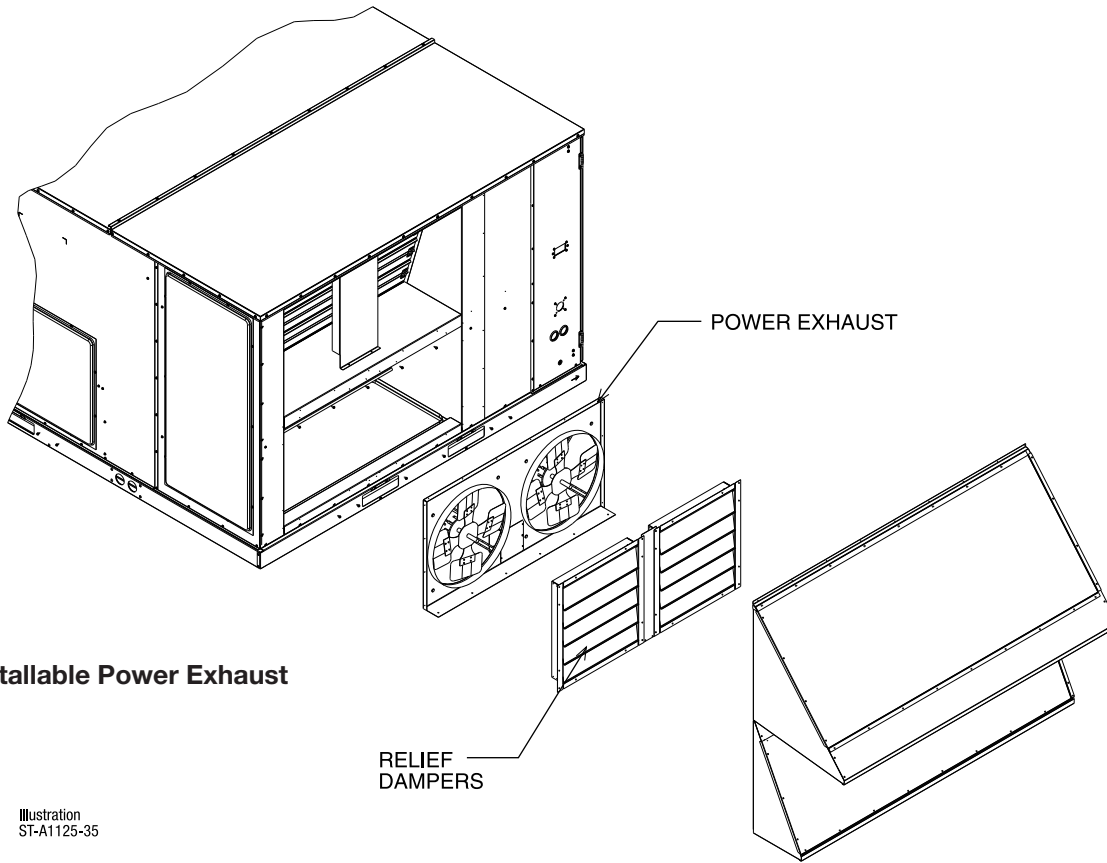

Field Installable Power Exhaust

Illustration
ST-A1125-35

Model No.	No. of Fans	Volts	Phase	HP (ea.)	Low Speed		High Speed ①		FLA (ea.)	LRA (ea.)
					CFM [L/s] ②	RPM	CFM [L/s] ②	RPM		
RXRX-BGF05C	2	208-230	1	0.75	4100 [1935]	850	5200 [2454]	1050	5	4.97
RXRX-BGF05D	2	460	1	0.75	4100 [1935]	850	5200 [2454]	1050	2.2	3.4
RXRX-BGF05Y	2	575	1	0.75	4100 [1935]	850	5200 [2454]	1050	1.5	2.84

NOTES: ① Power exhaust is factory set on high speed motor tap.

② CFM is per fan at 0" w.c. external static pressure.

[] Designates Metric Conversions

FRESH AIR DAMPER

MOTORIZED DAMPER KIT RXRX-AW03 (Motor Kit for AXRF-KFA1)

RXRX-AW05 (Modulating Motor Kit with position feedback for AXRF-KFA1)

- Features **Honeywell** Controls
- Gear Driven Direct Drive Actuator
- Fully Modulating (0-100%)
- Low Leakage Dampers
- Slip-In Design for Easy Installation
- Plug-In Polarized 12-pin and 4-pin Electrical Connections
- Pre-Configured—No Field Adjustments Necessary
- Addition of Dual Enthalpy Upgrade Kit allows limited economizer function
- CO₂ Sensor Input Available for Demand Control Ventilation (DCV)
- Optional Remote Minimum Position Potentiometer (270 ohm) (Honeywell #S963B1136) is available from Prostock
- All fresh air damper functions can be viewed at the RTU-C unit controller display
- If connected to a Building Automation System (BAS), all fresh air damper functions can be viewed on the (BAS), on 16 x 2 LCD screen
- If connected to thermostat, all fresh air damper functions can be viewed on 16 x 2 LCD screen

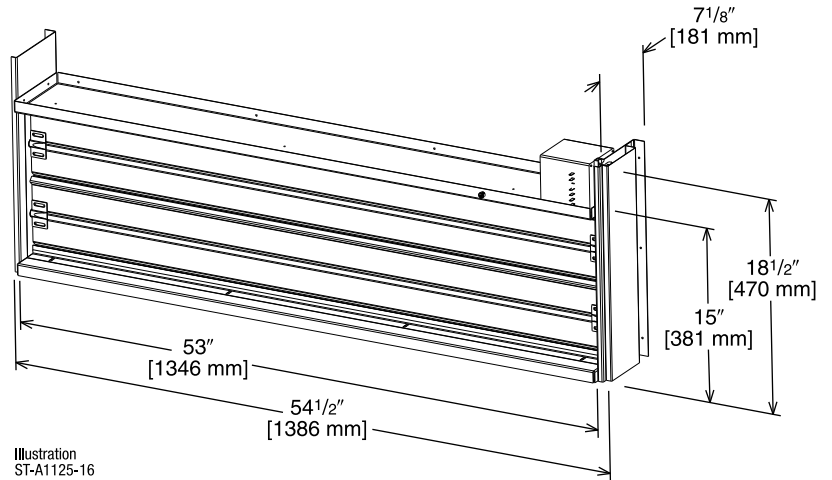

Illustration
ST-A1125-16

AXRF-KFA1 (Manual)

RXRX-AW03 (Motorized damper kit for manual fresh air damper)

RXRX-AW05 (Modulating Motor Kit with position feedback for AXRF-KFA1)

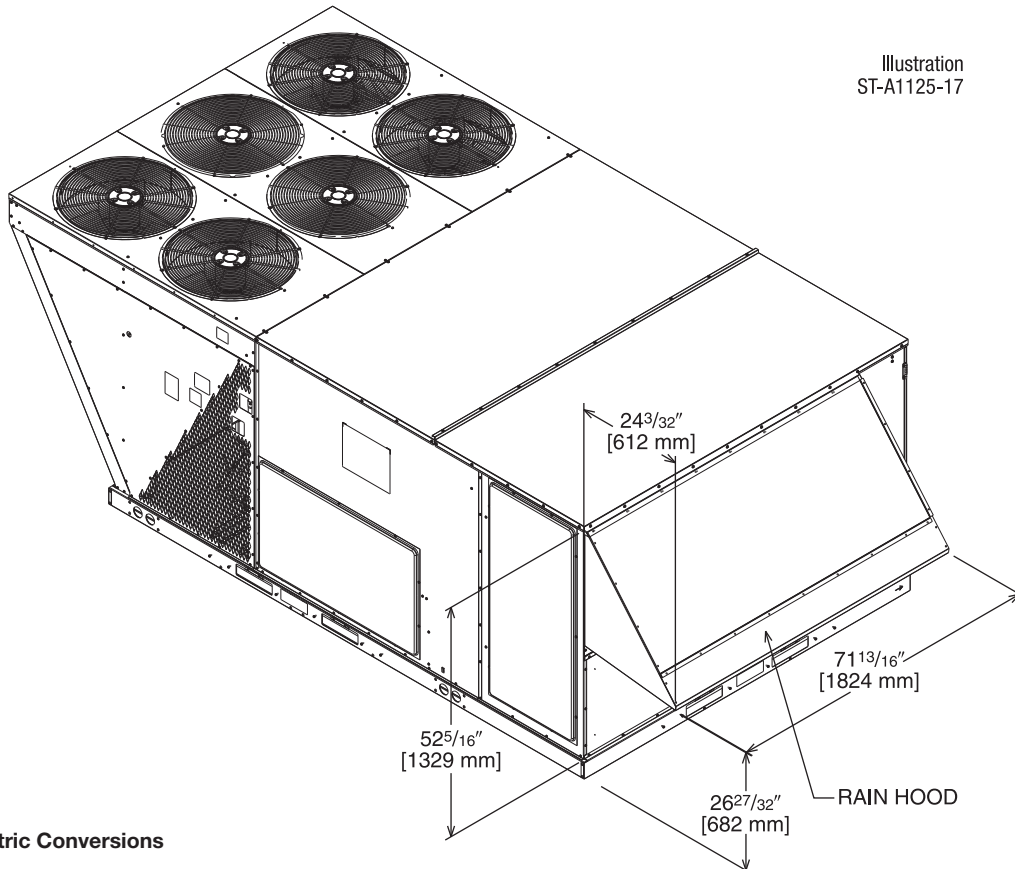

Illustration
ST-A1125-17

[] Designates Metric Conversions

ROOFCURBS (Full Perimeter)

- Rheem's roofcurb design can be utilized on 15 and 20 ton [52.8 and 70.3 kW] models.
- One available height (14" [356 mm]).
- Quick assembly corners for simple and fast assembly.
- 1" [25.4 mm] x 4" [102 mm] Nailers provided.
- Insulating panels not required because of insulated outdoor base pan.
- Sealing gasket (28" [711 mm]) provided with Roofcurb.
- Packaged for easy field assembly.

TYPICAL INSTALLATION

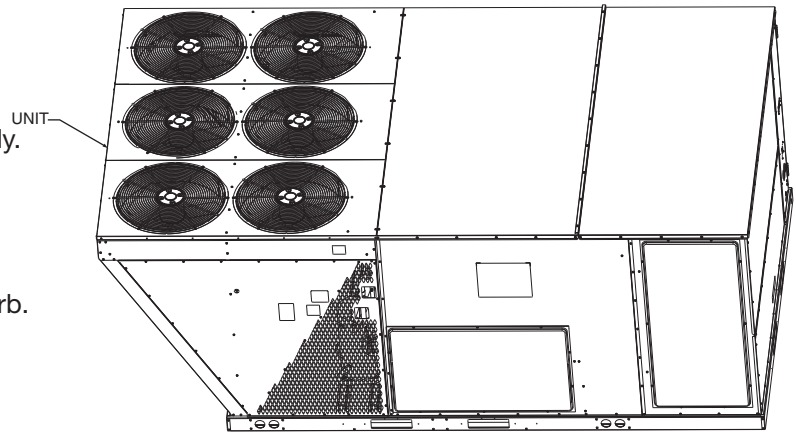

ROOFCURB ASSEMBLY

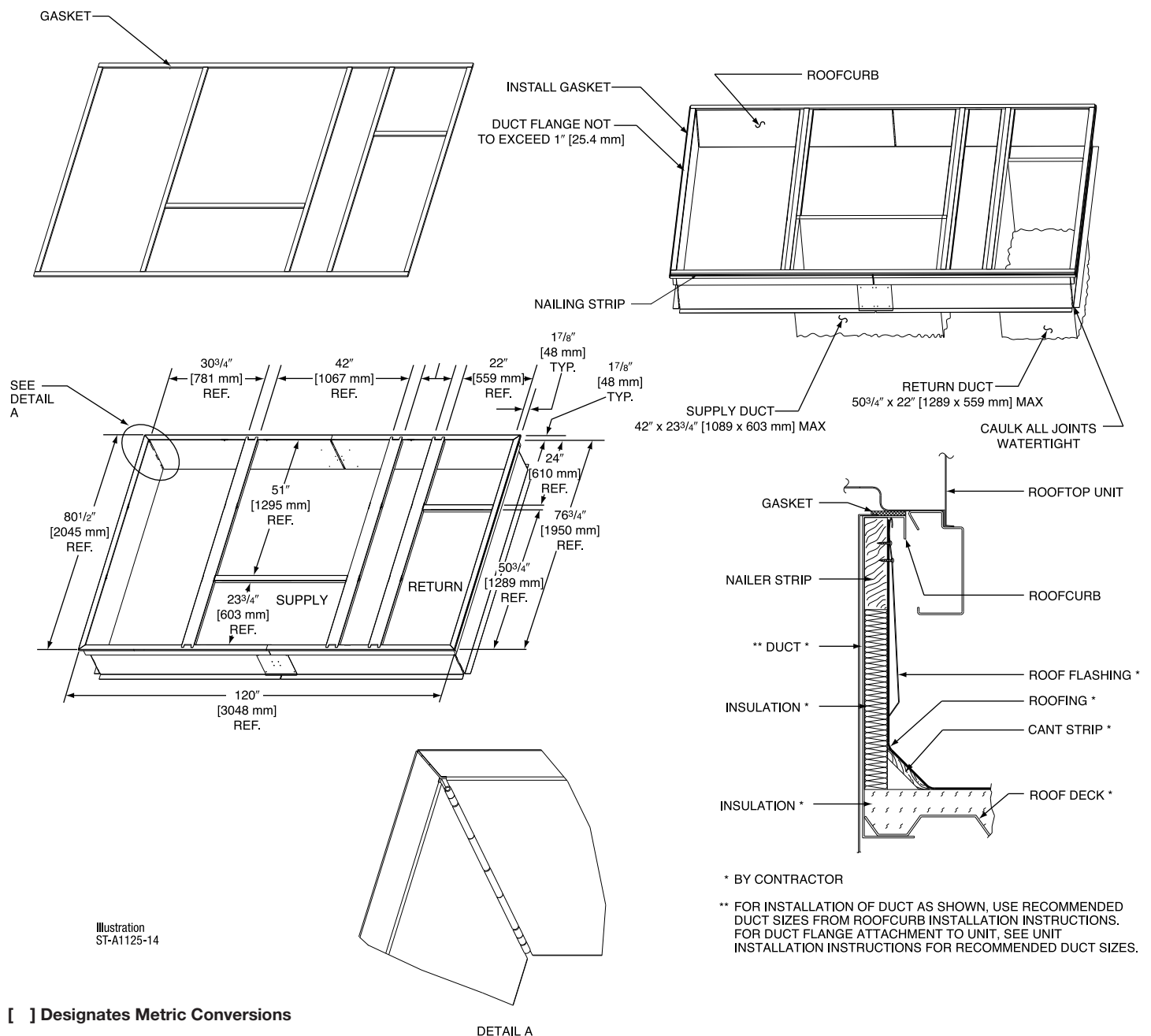

[] Designates Metric Conversions

ROOFCURB ADAPTERS

OLD MODELS

COMMERCIAL CABINET
(12.5, 15 & 20 TON)
([44, 52.8 & 70.3 kW])
(-)RCF, (-)RGF, (-)REF

OLD CURB MODEL

RXRK-E56

ROOFCURB ADAPTER

RXRX-CJCE56

NEW MODEL

RLRL-C/H
(15 & 20 TON)
([52.8 & 70.3 kW])

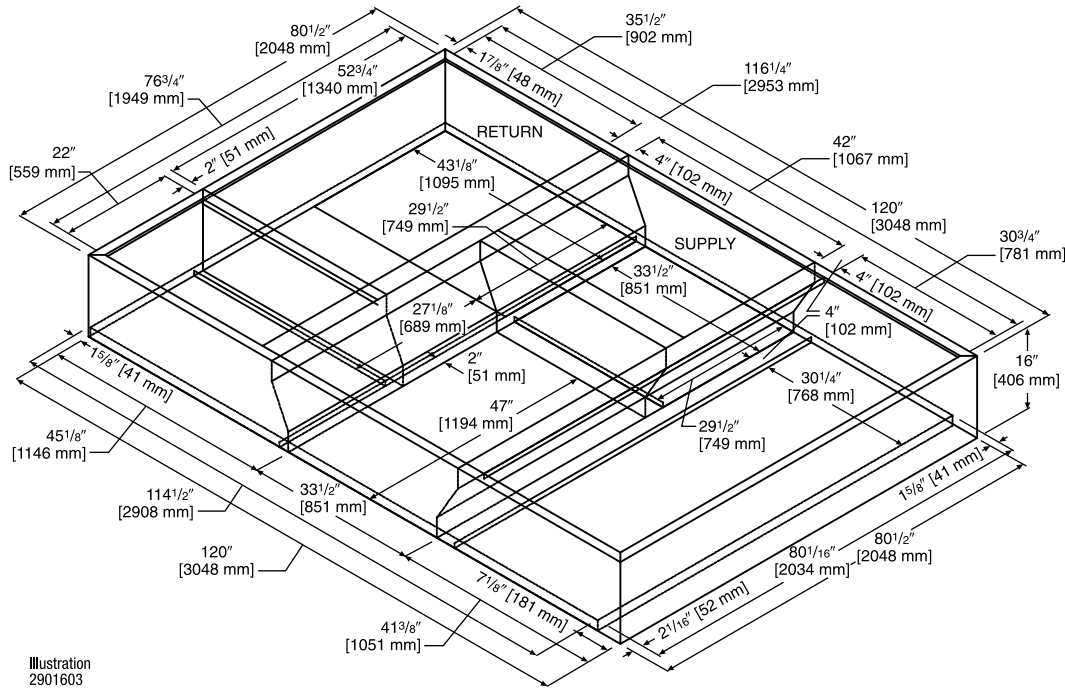

Illustration
2901603

COMMERCIAL CABINET
(15, 20 & 25 TON)
([52.8, 70.3 & 87.9 kW])
(-)LKB, LMB, LNB

RXKG-CAF14

RXRX-CJCF14

RLRL-C/H
(15 & 20 TON)
([52.8 & 70.3 kW])

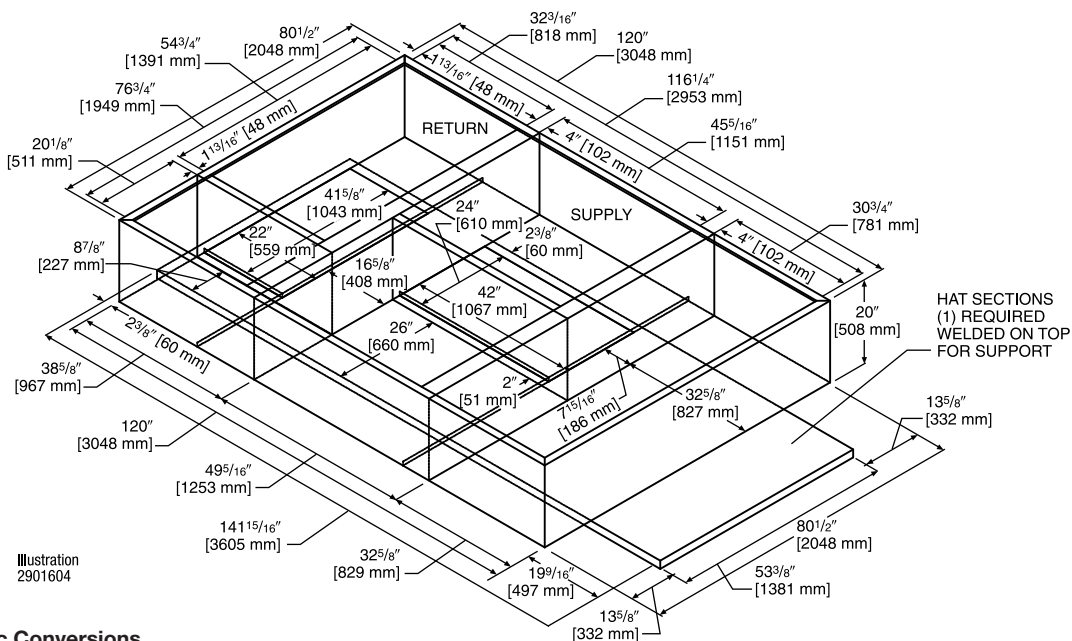

Illustration
2901604

HAT SECTIONS
(1) REQUIRED
WELDED ON TOP
FOR SUPPORT

[] Designates Metric Conversions

CONCENTRIC DIFFUSER APPLICATION

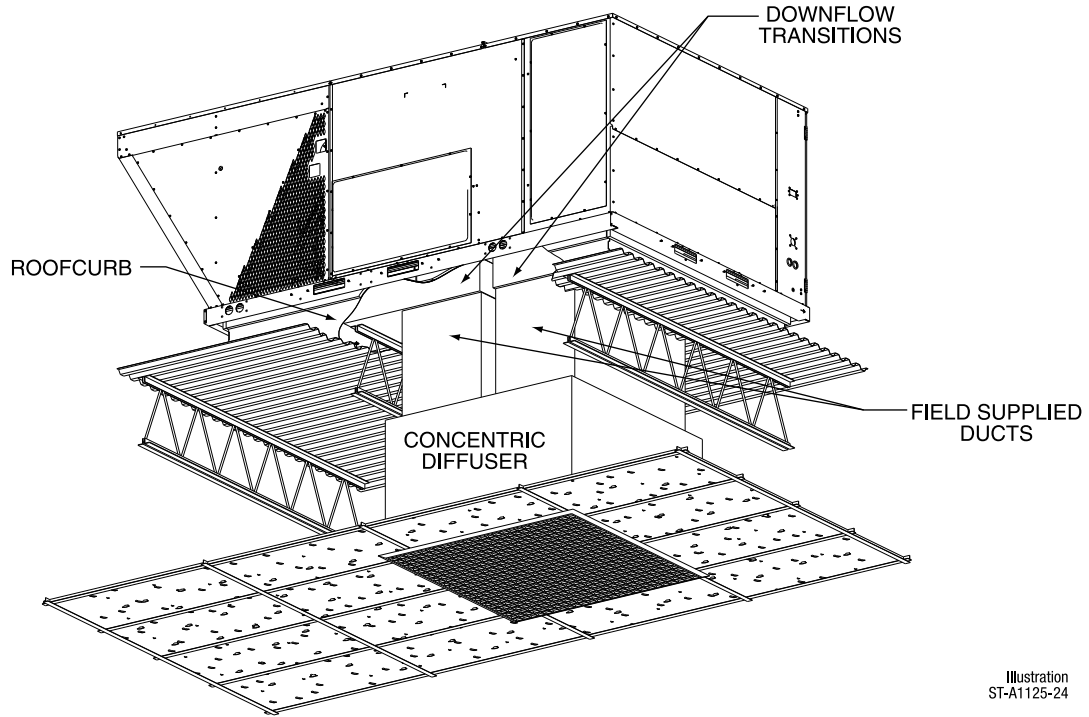

Illustration
ST-A1125-24

DOWNFLOW TRANSITION DRAWINGS

RXMC-CJ07 (15 Ton) [52.8 kW]

- Used with RXRN-AD80 and RXRN-AD81 Concentric Diffusers

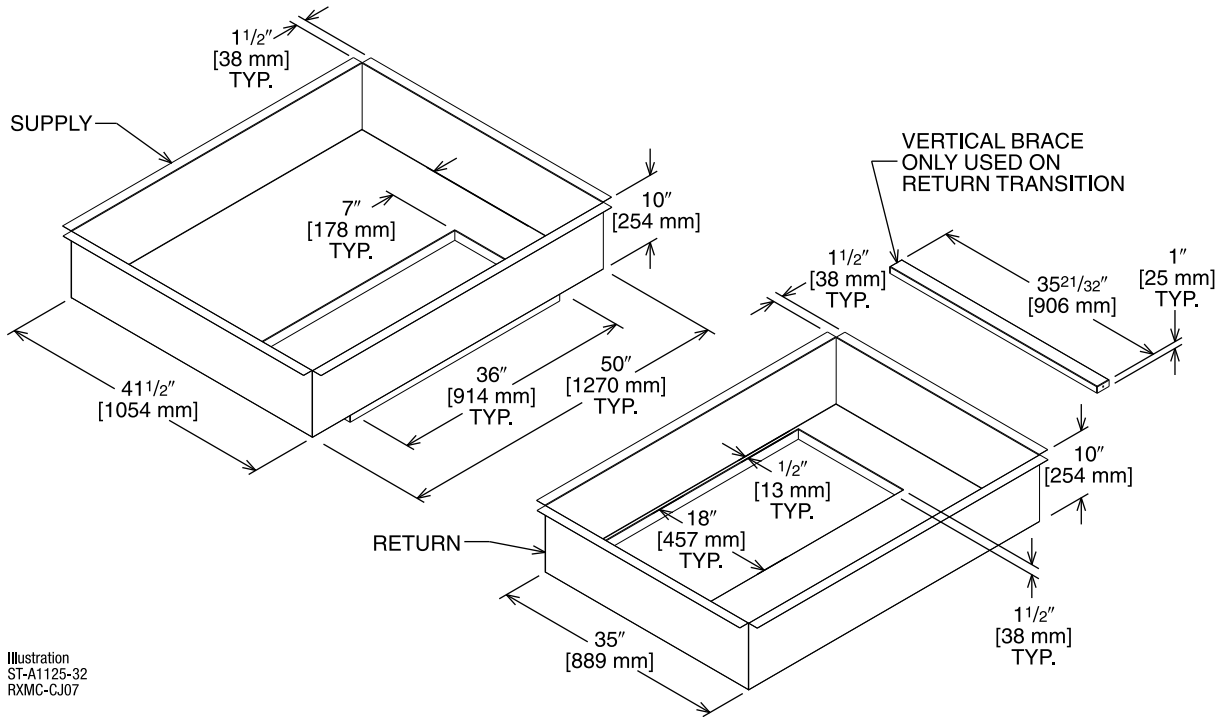

Illustration
ST-A1125-32
RXMC-CJ07

[] Designates Metric Conversions

DOWNFLOW TRANSITION DRAWINGS (Cont.)

RXMC-CK08 (20 Ton) [70.3 kW]

- Used with RXRN-AD86 Concentric Diffusers

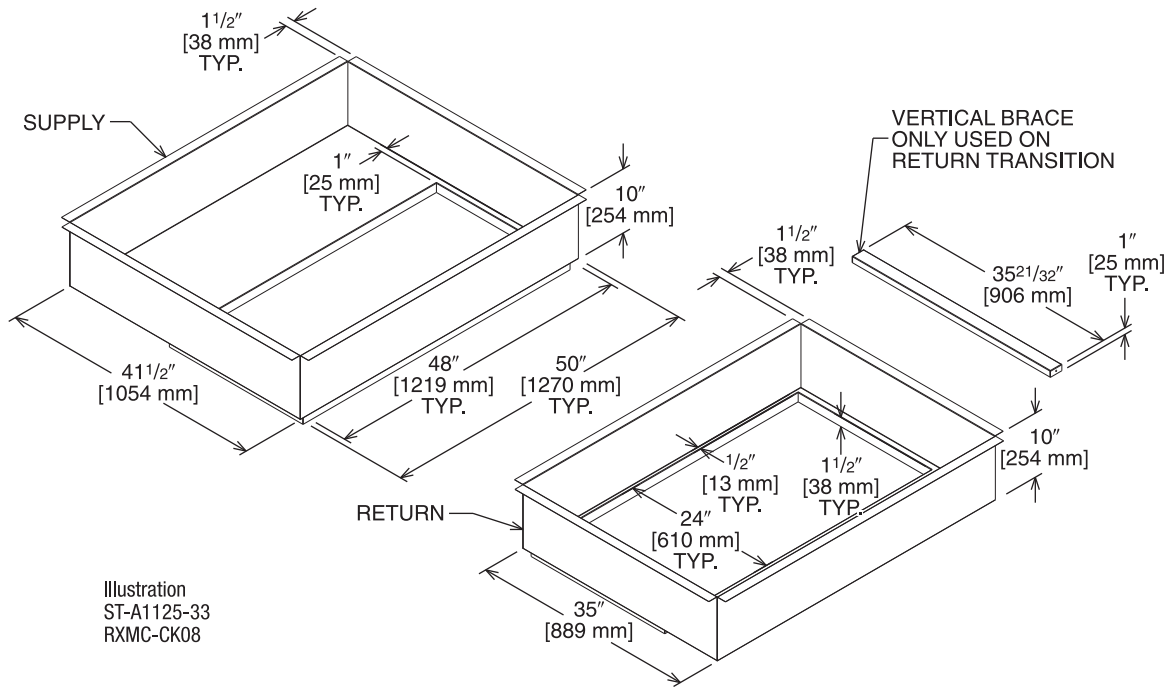

[] Designates Metric Conversions

CONCENTRIC DIFFUSER 15 TON [52.8 kW] FLUSH

- All aluminum diffuser with aluminum return air eggcrate.
- Built-in anti-sweat gasket.
- Molded fiberglass supports.
- Built-in hanging supports.
- Diffuser box constructed of sheetmetal insulated with 1" [25.4 mm] 1.5 lbs. [.7 kg] duct liner.

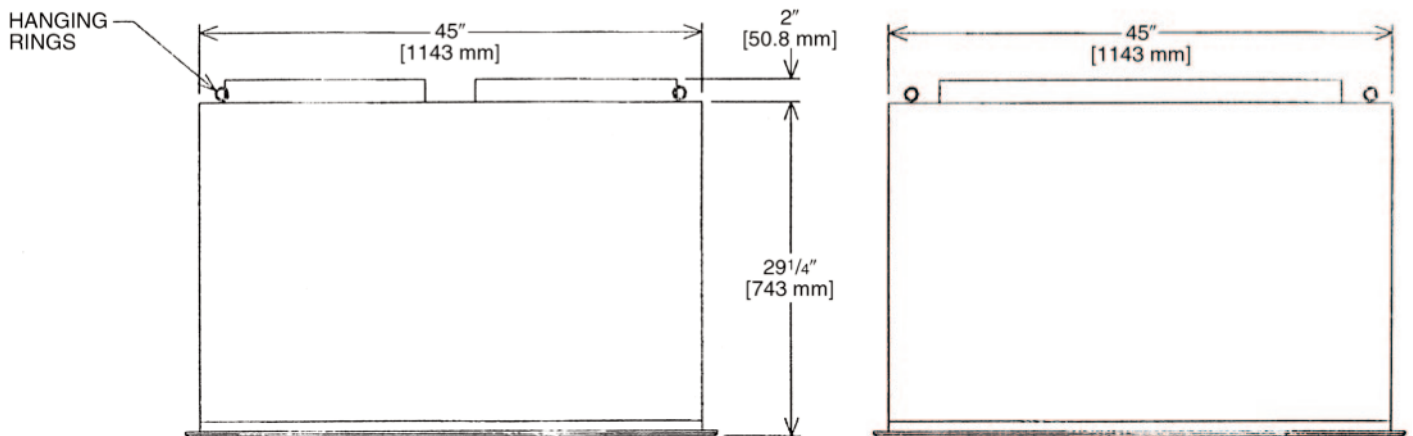
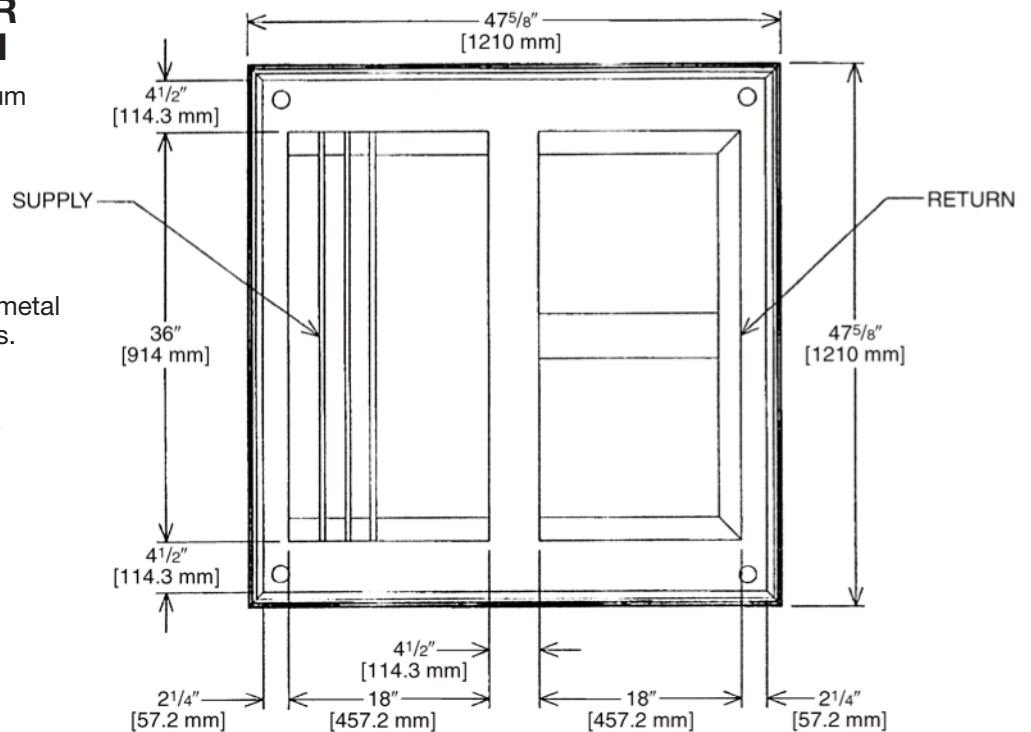

CONCENTRIC DIFFUSER SPECIFICATIONS

PART NUMBER	CFM [L/s]	STATIC PRESSURE	THROW FEET	NECK VELOCITY	JET VELOCITY
RXRN-AD80	5600 [2643]	0.36	28-37	1000	2082
	5800 [2737]	0.39	29-38	1036	2156
	6000 [2832]	0.42	40-50	1071	2230
	6200 [2926]	0.46	42-51	1107	2308
	6400 [3020]	0.50	43-52	1143	2379
	6600 [3115]	0.54	45-56	1179	2454

[] Designates Metric Conversions

CONCENTRIC DIFFUSER 15 TON [52.8 kW] STEP DOWN

- All aluminum diffuser with aluminum return air eggcrate.
- Built-in anti-sweat gasket.
- Molded fiberglass supports.
- Built-in hanging supports.
- Diffuser box constructed of sheetmetal insulated with 1" [25.4 mm] 1.5 lbs. [.7 kg] duct liner.
- Double deflection diffuser with the blades secured by spring steel.

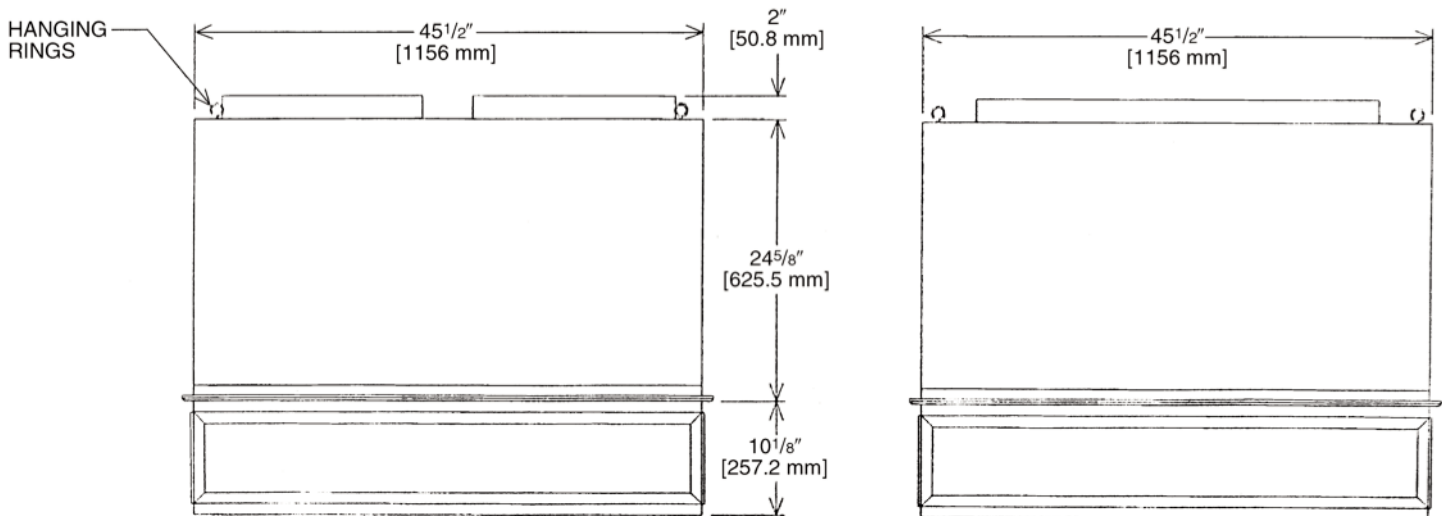
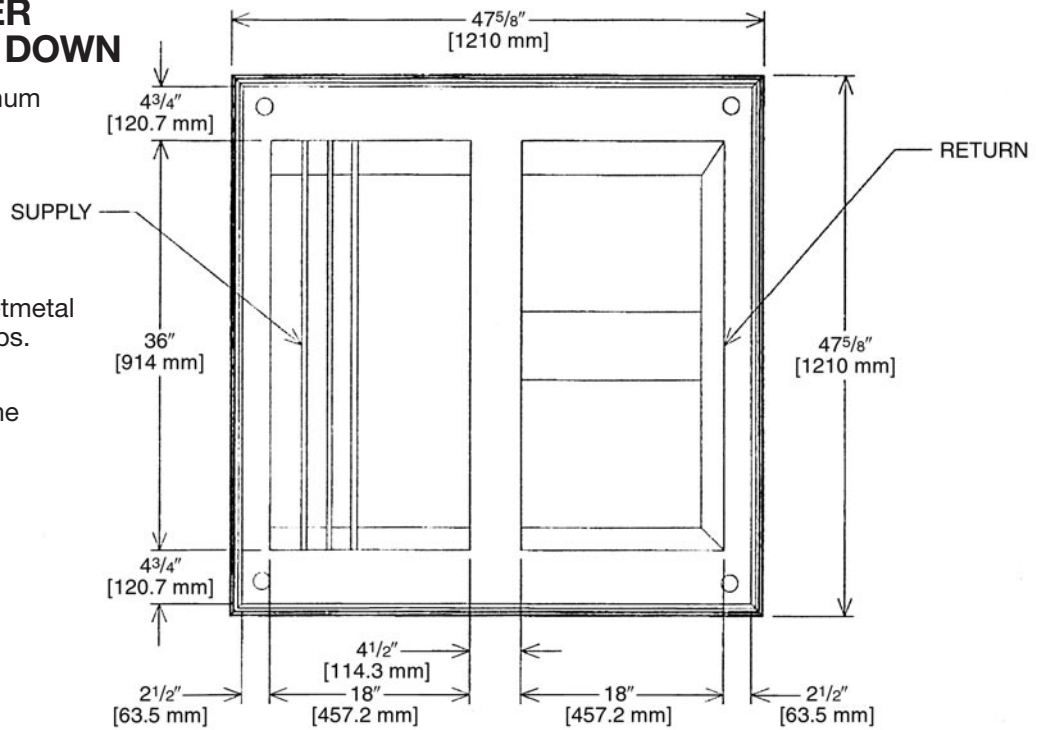

CONCENTRIC DIFFUSER SPECIFICATIONS

PART NUMBER	CFM [L/s]	STATIC PRESSURE	THROW FEET	NECK VELOCITY	JET VELOCITY
RXRN-AD81	5600 [2643]	0.36	39-49	920	920
	5800 [2737]	0.39	42-51	954	954
	6000 [2832]	0.42	44-54	1022	1022
	6200 [2926]	0.46	45-55	1056	1056
	6400 [3020]	0.50	46-55	1090	1090
	6600 [3115]	0.54	47-56	1124	1124

[] Designates Metric Conversions

CONCENTRIC DIFFUSER RXRN-AD86 SERIES 20 TON [70.3 kW] STEP DOWN

- All aluminum diffuser with aluminum return air eggcrate.
- Built-in anti-sweat gasket.
- Molded fiberglass supports.
- Built-in hanging supports.
- Diffuser box constructed of sheetmetal insulated with 1" [25.4 mm] 1.5 lbs. [.7 kg] duct liner.
- Double deflection diffuser with the blades secured by spring steel.

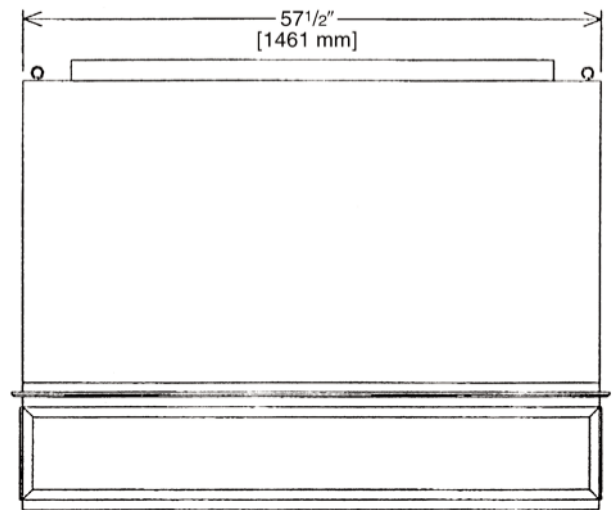
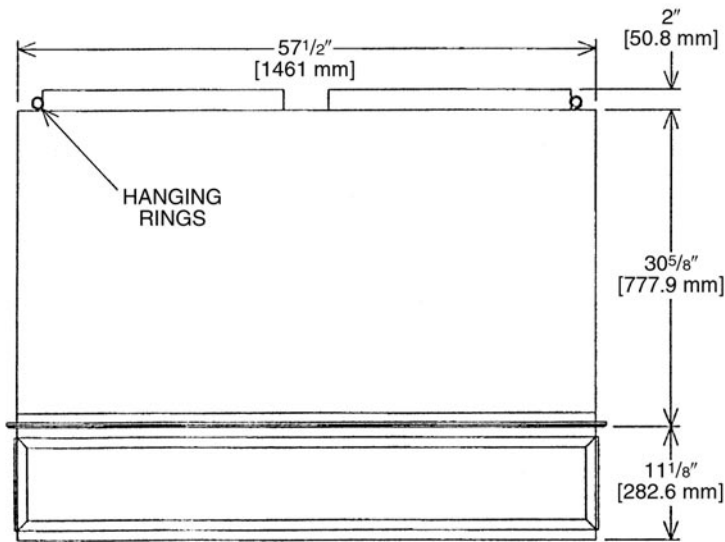
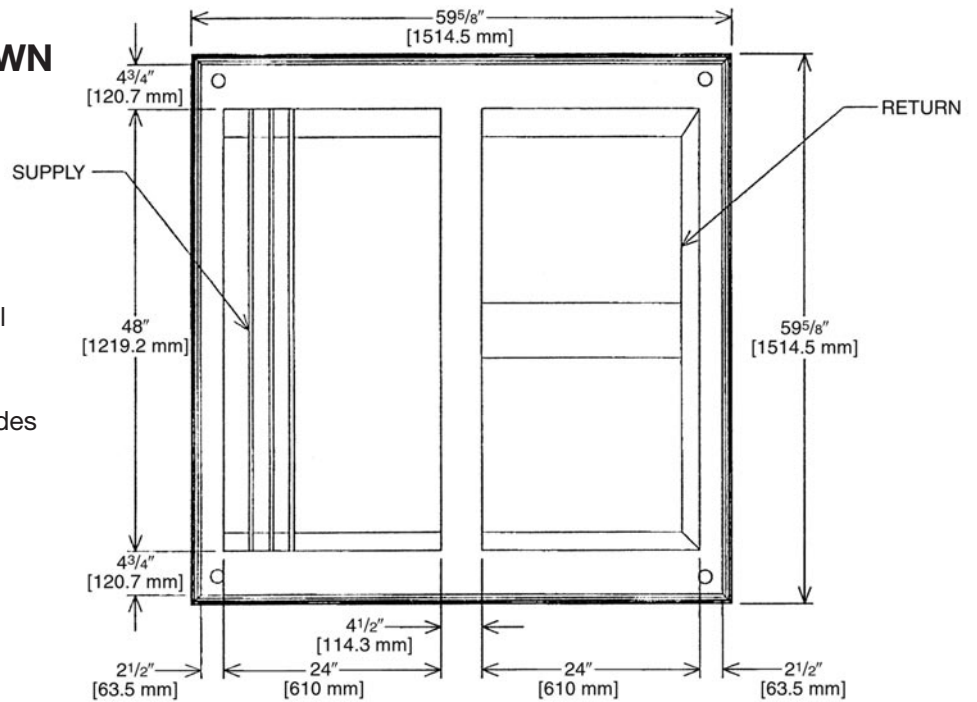

CONCENTRIC DIFFUSER SPECIFICATIONS

PART NUMBER	CFM [L/s]	STATIC PRESSURE	THROW FEET	NECK VELOCITY	JET VELOCITY
RXRN-AD86	7200 [3398]	0.39	33-38	827	827
	7400 [3492]	0.41	35-40	850	850
	7600 [3587]	0.43	36-41	873	873
	7800 [3681]	0.47	38-43	896	896
	8000 [3776]	0.50	39-44	918	918
	8200 [3870]	0.53	41-46	941	941
	8400 [3964]	0.56	43-49	964	964
	8600 [4059]	0.59	44-50	987	987
	8800 [4153]	0.63	47-55	1010	1010

[] Designates Metric Conversions

Guide Specifications – RLRL-H180 & H240

You may copy this document directly into your building specification. This specification is written to comply with the 2004 version of the “master format” as published by the Construction Specification Institute. www.csinet.org.

ELECTRIC HEAT PACKAGED ROOFTOP

HVAC Guide Specifications

Size Range: 15 to 25 Nominal Tons

Section	Description
---------	-------------

23 06 80	Schedules for Decentralized HVAC Equipment
-----------------	---

23 06 80.13	Decentralized Unitary HVAC Equipment Schedule
-------------	---

23 06 80.13.A.	Rooftop unit schedule
----------------	-----------------------

1. Schedule is per the project specification requirements.

23 07 16	HVAC Equipment Insulation
-----------------	----------------------------------

23 07 16.13	Decentralized, Rooftop Units:
-------------	-------------------------------

1. Interior cabinet surfaces shall be insulated with a minimum 3/4-in. thick, minimum 1-1/2 lb. density, flexible fiberglass insulation bonded with a phenolic binder, with aluminum foil facing on the air side.

2. Insulation and adhesive shall meet NFPA 90A requirements for flame spread and smoke generation.

23 09 13	Instrumentation and Control Devices for HVAC
-----------------	---

23 09 13.23	Sensors and Transmitters
-------------	--------------------------

23 09 13.23.A.	Thermostats
----------------	-------------

1. Thermostat must
 - a. have capability to energize 2 different stages of cooling, and 2 different stages of heating.
 - b. must include capability for occupancy scheduling.

23 09 23	Direct-digital Control system for HVAC
-----------------	---

23 09 23.13	Decentralized, Rooftop Units:
-------------	-------------------------------

23 09 23.13.A.	RTU-C controller
----------------	------------------

1. Shall be ASHRAE 62-2019 compliant.
2. Shall accept 18-32VAC input power.
3. Shall have an operating temperature range from -40°F (-40°C) to 158°F (70°C), 10% - 95% RH (non-condensing).
4. Controller shall accept the following inputs: space temperature, setpoint adjustment, outdoor air temperature, indoor air quality, outdoor air enthalpy, fire shutdown, return air enthalpy, fan status, remote time clock/door switch.
5. Shall accept a CO₂ sensor in the conditioned space, and be Demand Control Ventilation (DCV) ready.
6. Shall provide the following outputs: Economizer, fan, cooling stage 1, cooling stage 2, heat stage 1, heat stage 2, exhaust, occupied.
7. Unit shall provide surge protection for the controller through a circuit breaker.
8. Shall have a field installed communication card allowing the unit to be Internet capable, and communicate at a Baud rate of 19.2K or faster
9. Shall have an LED display independently showing the status of activity on the communication bus, and processor operation.
10. Shall have either a field installed BACnet® plug-in communication card which includes an EIA-485 protocol communication port, or a field installed LonWorks™ plug-in communications card.
11. Software upgrades will be accomplished by local download. Software upgrades through chip replacements are not allowed.
12. Shall be shock resistant in all planes to 5G peak, 11ms during operation, and 100G peak, 11ms during storage.
13. Shall be vibration resistant in all planes to 1.5G @ 20-300 Hz.
14. Shall support a bus length of 4000 ft max, 60 devices per 1000 ft section, and 1 RS-485 repeater per 1000 ft sections.

23 09 23.13.B.	Open protocol, direct digital controller:
----------------	---

1. Shall be ASHRAE 62-2001 compliant.
2. Shall accept 18-30VAC, 50-60Hz, and consumer 15VA or less power.
3. Shall have an operating temperature range from -40°F (-40°C) to 130°F (54°C), 10% - 90% RH (non-condensing).
4. Shall have either a field installed BACnet® plug-in communication card which includes an EIA-485 protocol communication port, or a field installed LonWorks™ plug-in communications card.
5. The BACnet® plug in communication card shall include built-in protocol for BACNET (MS/TP and PTP modes)
6. The LonWorks™ plug in communication card shall include the Echelon processor required for all Lon applications.
7. Shall allow access of up to 62 network variables (SNVT). Shall be compatible with all open controllers
8. Baud rate Controller shall be selectable through the EIA-485 protocol communication port.
9. Shall have an LED display independently showing the status of serial communication, running, errors, power, all digital outputs, and all analog inputs.
10. Shall accept the following inputs: space temperature, setpoint adjustment, outdoor air temperature, indoor air quality, outdoor air enthalpy, compressor lock-out, fire shutdown, enthalpy switch, and fan status/filter status/ humidity/ remote occupancy.
11. Shall provide the following outputs: economizer, fan, cooling stage 1, cooling stage 2, heat stage 1, heat stage 2, exhaust.
12. Software upgrades will be accomplished by either local or remote download. No software upgrades through chip replacements are allowed.

23 09 33 Electric and Electronic Control System for HVAC

23 09 33.13 Decentralized, Rooftop Units:

23 09 33.13.A. General:

1. Shall be complete with self-contained low-voltage control circuit protected by a resettable circuit breaker on the 24-v transformer side. Transformer shall have 100VA capabilities.
2. Shall utilize color-coded wiring.
3. Shall include a central control terminal board to conveniently and safely provide connection points for vital control functions such as: smoke detectors, phase monitor, economizer, thermostat, DDC control options, loss of charge, freeze sensor, high pressure switches.
4. Unit shall include a minimum of one 10-pin screw terminal connection board for connection of control wiring.

23 09 33.23.B. Safeties:

1. Compressor over-temperature, over current.
2. Loss of charge switch.
 - a. Units with 2 compressors shall have different colored wires for the circuit 1 and circuit 2 low and high pressure switches.
 - b. Loss of charge switch shall use different color wire than the high pressure switch. The purpose is to assist the installer and service technician to correctly wire and or troubleshoot the rooftop unit.
 - c. Loss of charge switch shall have a different sized connector than the high pressure switch. They shall physically prevent the cross-wiring of the safety switches between the high and low pressure side of the system.
3. High-pressure switch.
 - a. Units with 2 compressors shall have different colored wires for the circuit 1 and circuit 2 low and high pressure switches.
 - b. High pressure switch shall use different color wire than the low pressure switch. The purpose is to assist the installer and service person to correctly wire and or troubleshoot the rooftop unit.
 - c. High pressure switch shall have a different sized connector than the loss of charge switch. They shall physically prevent the cross-wiring of the safety switches between the high and low pressure side of the system.
4. Freeze protection sensor, evaporator coil.
5. Automatic reset, motor thermal overload protector.

23 09 93 Sequence of Operations for HVAC Controls

23 09 93.13 Decentralized, Rooftop Units:

23 09 93.13 INSERT SEQUENCE OF OPERATION

23 40 13 Panel Air Filters

23 40 13.13 Decentralized, Rooftop Units:

23 40 13.13.A. Standard filter section shall

1. Shall consist of factory-installed, low velocity, throwaway 2-in. thick fiberglass filters of commercially available sizes.
2. Filters shall be accessible through an access panel as described in the unit cabinet section of this specification (23 81 19.13.H).

23 81 19 Self-Contained Air Conditioners

23 81 19.13 Small-Capacity Self-Contained Air Conditioners

23 81 19.13.A. General

1. Outdoor, rooftop mounted, electrically controlled, heating and cooling unit utilizing a(n) hermetic scroll compressor(s) for cooling duty and heat pump for heating duty.
2. Factory assembled, single-piece heating and cooling rooftop unit. Contained within the unit enclosure shall be all factory wiring, piping, controls, and special features required prior to field start-up.
3. Unit shall use environmentally sound R-410a refrigerant.
4. Unit shall be installed in accordance with the manufacturer's instructions.
5. Unit must be selected and installed in compliance with local, state, and federal codes.

23 81 19.13.B. Quality Assurance

1. Unit meets ASHRAE 90.1-2004 minimum efficiency requirements.
2. 3 phase units are Energy Star qualified.
3. Unit shall be rated in accordance with AHRI Standards 210/240 and 340/360.
4. Unit shall be designed to conform to ASHRAE 15, 2001.
5. Unit shall be UL-tested and certified in accordance with ANSI Z21.47 Standards and UL-listed and certified under Canadian standards as a total package for safety requirements.
6. Insulation and adhesive shall meet NFPA 90A requirements for flame spread and smoke generation.
7. Unit casing shall be capable of withstanding 500-hour salt spray exposure per ASTM B117 (scribed specimen).
8. Unit casing shall be capable of withstanding Federal Test Method Standard No. 141 (Method 6061) 5000-hour salt spray.
9. Unit shall be designed in accordance with ISO 9001:2000, and shall be manufactured in a facility registered by ISO 9001:2000.
10. Roof curb shall be designed to conform to NRCA Standards.
11. Unit shall be subjected to a completely automated run test on the assembly line. The data for each unit will be stored at the factory, and must be available upon request.
12. Unit shall be designed in accordance with UL Standard 1995, including tested to withstand rain.
13. Unit shall be constructed to prevent intrusion of snow and tested to prevent snow intrusion into the control box up to 40 mph.

23 81 19.13.C. Delivery, Storage, and Handling

1. Unit shall be stored and handled per manufacturer's recommendations.
2. Lifted by crane requires either shipping top panel or spreader bars.
3. Unit shall only be stored or positioned in the upright position.

23 81 19.13.E. Project Conditions

1. As specified in the contract.

23 81 19.13.F. Operating Characteristics

1. Unit shall be capable of starting and running at 115°F (46°C) ambient outdoor temperature, meeting maximum load criteria of AHRI Standard 210/240 or 340/360 at ± 10% voltage.
2. Compressor with standard controls shall be capable of operation from 40°F (4°C) , ambient outdoor temperatures. Accessory low ambient kit is necessary if mechanically cooling at ambient temperatures below 40°F (4°C).
3. Unit shall discharge supply air vertically or horizontally as shown on contract drawings.
4. Unit shall be factory configured for vertical supply & return configurations.
5. Unit shall be field convertible from vertical to horizontal configuration.

23 81 19.13.G. Electrical Requirements

1. Main power supply voltage, phase, and frequency must match those required by the manufacturer.

23 81 19.13.H. Unit Cabinet

1. Unit cabinet shall be constructed of galvanized steel, and shall be bonderized and coated with a baked enamel finish on all externally exposed surfaces.
2. Unit cabinet exterior paint shall be: film thickness, (dry) 0.003 inches minimum, gloss (per ASTM D523, 60°F): 60, Hardness: H-2H Pencil hardness.
3. Evaporator fan compartment interior cabinet insulation shall conform to AHRI Standards 210/240 or 340/360 minimum exterior sweat criteria. Interior surfaces shall be insulated with a minimum 3/4-in. thick, 1 lb density, flexible fiberglass insulation, aluminum foil-faced on the air side.
4. Base of unit shall have locations for thru-the-base electrical connections (factory installed or field installed), standard.
5. Base Rail
 - a. Unit shall have base rails on all sides.
 - b. Holes shall be provided in the base rails for rigging shackles to facilitate maneuvering and overhead rigging.
 - c. Holes shall be provided in the base rail for moving the rooftop by fork truck.
 - d. Base rail shall be a minimum of 14 gauge thickness.
6. Condensate pan and connections:
 - a. Shall be a sloped condensate drain pan made of a non-corrosive material.
 - b. Shall comply with ASHRAE Standard 62.
 - c. Shall use a 1" -11 1/2 NPT drain connection, through the side of the drain pan. Connection shall be made per manufacturer's recommendations.
7. Electrical Connections
 - a. All unit power wiring shall enter unit cabinet at a single, factory-prepared, knockout location.
 - b. Thru-the-base capability
 - (1.) Standard unit shall have a thru-the-base electrical location(s) using a raised, embossed portion of the unit basepan.
 - (2.) No basepan penetration, other than those authorized by the manufacturer, is permitted.
8. Component access panels (standard)
 - a. Cabinet panels shall be easily removable for servicing.
 - b. Stainless steel metal hinges are standard on all doors.
 - c. Panels covering control box, indoor fan, indoor fan motor, and electric or gas heater components (where applicable), shall have 1/4 turn latches.

23 81 19.13.J. Coils

1. Standard Aluminum/Copper Coils: on all models.
 - a. Standard evaporator and condenser coils shall have aluminum lanced plate fins mechanically bonded to seamless internally grooved copper tubes with all joints brazed.
 - b. Evaporator and Condenser coils shall be leak tested to 150 psig, pressure tested to 550 psig, and qualified to UL 1995 burst test at 2,200 psig.

23 81 19.13.K. Refrigerant Components

1. Refrigerant circuit shall include the following control, safety, and maintenance features:
 - a. Thermal Expansion Valve (TXV) with orifice type distributor
 - b. Refrigerant filter drier.
 - c. External service gauge connections to unit suction and discharge lines.
 - d. Pressure gauge access through an access port in the front and rear panel of the unit.
2. Compressors
 - a. Unit shall use one fully hermetic, scroll compressor for each independent refrigeration circuit.
 - b. Compressor motors shall be cooled by refrigerant gas passing through motor windings.
 - d. Compressors shall be internally protected from high discharge temperature conditions. Advanced Scroll Temperature Protection on 240-300 sizes.

- e. Compressors shall be protected from an over-temperature and over-ampere conditions by an internal, motor overload device.
- f. Compressor shall be factory mounted on rubber grommets.
- g. Compressor motors shall have internal line break thermal, current overload and high pressure differential protection.
- h. Crankcase heaters shall not be required for normal operating range.

23 81 19.13.L. Filter Section

- 1. Filters access is specified in the unit cabinet section of this specification.
- 2. Filters shall be held in place by a sliding filter tray, facilitating easy removal and installation.
- 3. Shall consist of factory-installed, low velocity, throw-away 2-in. thick fiberglass filters.
- 4. Filters shall be standard, commercially available sizes.
- 5. Filter face velocity shall not exceed 365 fpm at nominal airflows.

23 81 19.13.M. Evaporator Fan and Motor

- 1. Evaporator fan motor:
 - a. Shall have permanently lubricated bearings.
 - b. Shall have inherent automatic-reset thermal overload protection or circuit breaker.
 - c. Shall have a maximum continuous bhp rating for continuous duty operation; no safety factors above that rating shall be required.
- 2. Belt-driven Evaporator Fan:
 - a. Belt drive shall include an adjustable-pitch motor pulley.
 - b. Shall use sealed, permanently lubricated ball-bearing type.
 - c. Blower fan shall be double-inlet type with forward-curved blades.
 - d. Shall be constructed from steel with a corrosion resistant finish and dynamically balanced.

23 81 19.13.N. Condenser Fans and Motors

- 1. Condenser fan motors:
 - a. Shall be a totally enclosed motor.
 - b. Shall use permanently lubricated bearings.
 - c. Shall have inherent thermal overload protection with an automatic reset feature.
 - d. Shall use a shaft-down design. Shaft-up designs including those with “rain-slinger devices” shall not be allowed.
- 2. Condenser Fans:
 - a. Shall be a direct-driven propeller type fan.
 - b. Shall have aluminum blades riveted to corrosion-resistant steel spiders and shall be dynamically balanced.

23 81 19.13.O. Special Features, Options and Accessories

- 1. Integrated Economizers:
 - a. Integrated, gear-driven parallel modulating blade design type capable of simultaneous economizer and compressor operation.
 - b. Independent modules for vertical or horizontal return configurations shall be available. Vertical return modules shall be available as a factory installed option.
 - c. Damper blades shall be galvanized steel with metal gears. Plastic or composite blades on intake or return shall not be acceptable.
 - d. Shall include all hardware and controls to provide free cooling with outdoor air when temperature and/or humidity are below setpoints.
 - e. Shall be equipped with gear driven dampers for both the outdoor ventilation air and the return air for positive air stream control.
 - f. Shall be capable of introducing up to 100% outdoor air.
 - g. Shall be equipped with a barometric relief damper capable of relieving up to 100% return air.
 - h. Shall be designed to close damper(s) during loss-of-power situations with spring return built into motor.
 - i. An outdoor single enthalpy sensor shall be provided as standard. Outdoor air sensor setpoint shall be adjustable and shall range from the enthalpy equivalent of 63°F @ 50% rh to 73°F @ 50% rh. Additional sensor options shall be available as accessories.
 - j. The economizer controller shall also provide control of an accessory power exhaust unit function. Factory set at 70%, with a range of 0% to 100%.
 - k. The economizer shall maintain minimum airflow into the building during occupied period and provide design ventilation rate for full occupancy. A remote potentiometer may be used to override the damper setpoint.
 - l. Dampers shall be completely closed when the unit is in the unoccupied mode.
 - m. Economizer controller shall accept a 2-10Vdc CO₂ sensor input for IAQ/DCV control. In this mode, dampers shall modulate the outdoor-air damper to provide ventilation based on the sensor input.
 - n. Compressor lockout sensor on the unit controller is factory set at 35°F and is adjustable from 30°F (-1°C) to 50°F (10°C) and resets the cooling lockout at 5°F (+2.7°C) above the set point.
 - o. Actuator shall be direct coupled to economizer gear. No linkage arms or control rods shall be acceptable.
 - p. Economizer controller shall provide indications when in free cooling mode, in the DCV mode, or the exhaust fan contact is closed.
 - q. Economizer wire harness will have provision for smoke detector.

2. Two-Position Motorized Damper
 - a. Damper shall be a Two-Position Motorized Damper. Damper travel shall be from the full closed position to the field adjustable %-open setpoint.
 - b. Damper shall include adjustable damper travel from 25% to 100% (full open).
 - c. Damper shall include single or dual blade, gear driven dampers and actuator motor.
 - d. Actuator shall be direct coupled to damper gear. No linkage arms or control rods shall be acceptable.
 - e. Damper will admit up to 100% outdoor air for applicable rooftop units.
 - f. Damper shall close upon indoor (evaporator) fan shutoff and/or loss of power.
 - g. The damper actuator shall plug into the rooftop unit's wiring harness plug. No hard wiring shall be required.
 - h. Outside air hood shall include aluminum water entrainment filter
3. Manual damper
 - a. Manual damper package shall consist of damper, air inlet screen, and rain hood which can be preset to admit up to 50% outdoor air for year round ventilation.
4. Head Pressure Control Package
 - a. Controller shall control coil head pressure by condenser-fan cycling.
5. Condenser Coil Hail Guard Assembly
 - a. Shall protect against damage from hail.
 - b. Shall be louvered design.
6. Convenience Outlet:
 - a. Non-Powered convenience outlet.
 - (1.) Outlet shall be powered from a separate 115-120v power source.
 - (2.) A transformer shall not be included.
 - (3.) Outlet shall be factory-installed and internally mounted with easily accessible 115-v female receptacle.
 - (4.) Outlet shall include 15 amp GFI receptacles.
 - (5.) Outlet shall be accessible from outside the unit.
7. Fan/Filter Status Switch:
 - a. Switch shall provide status of indoor evaporator fan (ON/OFF) or filter (CLEAN/DIRTY).
 - b. Status shall be displayed either over communication bus (when used with direct digital controls) or through the controller LCD display inside the unit control box.
8. Propeller Power Exhaust:
 - a. Power exhaust shall be used in conjunction with an integrated economizer.
 - b. Independent modules for vertical or horizontal return configurations shall be available.
 - c. Horizontal power exhaust is shall be mounted in return ductwork.
 - d. Power exhaust shall be controlled by economizer controller operation. Exhaust fans shall be energized when dampers open past the 0-100% adjustable setpoint on the economizer control.
9. Roof Curbs (Vertical):
 - a. Full perimeter roof curb with exhaust capability providing separate air streams for energy recovery from the exhaust air without supply air contamination.
 - b. Formed galvanized steel with wood nailer strip and shall be capable of supporting entire unit weight.
 - c. Permits installation and securing of ductwork to curb prior to mounting unit on the curb.
10. High-Static Indoor Fan Motor(s) and Drive(s):
 - a. High-static motor(s) and drive(s) shall be factory-installed to provide additional performance range.
11. Outdoor Air Enthalpy Sensor:
 - a. The outdoor air enthalpy sensor shall be used to provide single enthalpy control. When used in conjunction with a return air enthalpy sensor, the unit will provide differential enthalpy control. The sensor allows the unit to determine if outside air is suitable for free cooling.
13. Return Air Enthalpy Sensor:
 - a. The return air enthalpy sensor shall be used in conjunction with an outdoor air enthalpy sensor to provide differential enthalpy control.
14. Indoor Air Quality (CO₂) Sensor:
 - a. Shall be able to provide demand ventilation indoor air quality (IAQ) control.
 - b. The IAQ sensor shall be available in wall mount with LED display. The setpoint shall have adjustment capability.
15. Smoke detectors:
 - a. Shall be a Four-Wire Controller and Detector.
 - b. Shall be environmental compensated with differential sensing for reliable, stable, and drift-free sensitivity.
 - c. Shall use magnet-activated test/reset sensor switches.
 - d. Shall have a recessed momentary switch for testing and resetting the detector.
 - e. Controller shall include:

- (1.) One set of normally open alarm initiation contacts for connection to an initiating device circuit on a fire alarm control panel.
 - (2.) Two Form-C auxiliary alarm relays for interface with rooftop unit or other equipment.
 - (3.) One Form-C supervision (trouble) relay to control the operation of the Trouble LED on a remote test/reset station.
 - (4.) Capable of direct connection to two individual detector modules.
 - (5.) Can be wired to up to 14 other duct smoke detectors for multiple fan shutdown applications.
16. Electric Heat:
- a. Heating Section
 - (1.) Heater element open coil resistance wire, nickel-chrome alloy, strung through ceramic insulators mounted on metal frame. Coil ends are staked and welded to terminal screw slots.
 - (2.) Heater assemblies are provided with integral fusing for protection of internal heater circuits not exceeding 48 amps each. Auto reset thermo limit controls, magnetic heater contactors (24 v coil) and terminal block all mounted in electric heater control box (minimum 18 ga galvanized steel) attached to end of heater assembly.

26 29 23.12 Adjustable Frequency Drive

1. Unit shall be supplied with an electronic variable frequency drive for the supply air fan.
2. Drive shall be factory installed in an enclosed cabinet.
3. Drive shall meet UL Standard 95-5V.
4. The completed unit assembly shall be UL listed.
5. Drives are to be accessible through a tooled access hinged door assembly.
6. The unit manufacturer shall install all power and control wiring.
7. The supply air fan drive output shall be controlled by the factory installed main unit control system and drive status and operating speed shall be monitored and displayed at the main unit control panel.
8. Drive shall be programmed and factory run tested in the unit.

BEFORE PURCHASING THIS APPLIANCE, READ IMPORTANT ENERGY COST AND EFFICIENCY INFORMATION AVAILABLE FROM YOUR RETAILER.

GENERAL TERMS OF LIMITED WARRANTY*

Rheem will furnish a replacement for any part of this product which fails in normal use and service within the applicable periods stated, in accordance with the terms of the limited warranty.

***For complete details of the Limited and Conditional Warranties, including applicable terms and conditions, contact your local contractor or the Manufacturer for a copy of the product warranty certificate.**

Compressor	
3 Phase, Commercial Applications	Five (5) Years
Parts	
3 Phase, Commercial Applications.....	One (1) Year



The new degree of comfort.™

In keeping with its policy of continuous progress and product improvement, Rheem reserves the right to make changes without notice.

Rheem Heating, Cooling & Water Heating • 5600 Old Greenwood Road
Fort Smith, Arkansas 72908 • www.rheem.com

Rheem Canada Ltd./Ltée • 125 Edgeware Road, Unit 1
Brampton, Ontario • L6Y 0P5



INTEGRATED AIR & WATER