



The new degree of comfort.®

## Endeavor™ Line *Classic*® Series Gas Furnaces



### R951T

95% A.F.U.E.†

Heating Stages: Single Stage

Motor Type: Constant Torque

Input Rates: 40 to 115 kBTU [11.72 to 33.71 kW]

Configuration Options: 4-Way Multi-Position



† A.F.U.E. (Annual Fuel Utilization Efficiency) calculated in accordance with Department of Energy test procedures.

## Table of Contents

Features & Benefits .....	3
Model Number Identification .....	4
Physical Data and Specifications .....	5
Dimensional Data .....	6
Blower Performance Data .....	7
Accessories .....	8
Limited Warranty .....	12

## Features and Benefits

- **PlusOne® Energy Efficiency:** ENERGY STAR® certified, featuring 95% AFUE across all model sizes
- **PlusOne® Diagnostics:** Industry-first, 7-Segment LED for quick and easy service
- **PlusOne® Ignition System:** Proven Direct Spart Ignition (DSI) for reliability and longevity
- **PlusOne® Water Management System:** Rheem-exclusive patented block drain sensor that automatically shuts off the furnace when the drain is blocked and alerts the contractor via diagnostic code

# Gas Furnaces

<u>R</u>	<u>95</u>	<u>1</u>	<u>T</u>	<u>040</u>	<u>3</u>	<u>A</u>	<u>17</u>	<u>M4</u>	<u>S</u>	<u>N</u>	<u>A</u>	<u>S</u>
Brand	Furnace Efficiency	Stages of Heating	Motor Type	Heating Input	AC Max. Capacity	Major Series	Width	Position	NOx	Controls	Minor Series	Option Code
R - Rheem	95 - 95% AFUE	1 - Single-Stage	T - Constant Torque	040 - 40,000 [11.7 kW] 060 - 60,000 [17.6 kW] 070 - 70,000 [20.5 kW] 085 - 85,000 [24.9 kW]	3 - 3 ton drive 5 - 5 ton drive	A - 1st Design Series	17 - 17.5" Width 21 - 21" Width 24 - 24.5" Width	M4 - Multi-4 Way	S - Standard	N - Non-Communicating	A - 1st Series	S - Standard Grade

[ ] Designates Metric Conversions

AVAILABLE MODELS
R951T0403A17M4SNAS
R951T0603A17M4SNAS
R951T0703A17M4SNAS
R951T0705A21M4SNAS
R951T0855A21M4SNAS
R951T1005A21M4SNAS
R951T1155A24M4SNAS

STANDARD EQUIPMENT
100% Safety Lock Out
29-4c Stainless Steel Secondary Heat Exchanger Design
7 Segment Led
Aluminized Steel Primary Heat Exchanger Design
Blocked Drain Sensor
Blower Compartment Door Safety Switch
Completely Assembled and Wired
Cool Fan Off Delay
Direct Drive Motor
Electronic Air Cleaner Connections
Field Selectable Heat Fan Off Delay
Flame Sense Current Diagnostics
Fully Insulated Heat Exchanger Cabinet
Humidifier Connections
Induced Draft Motor
Limit Controls
Low Speed Continuous Fan Option
Manual Shut-Off Valve
Marked Condensate Hoses
Multi-Speed Constant Torque Blower Motor
One Hour Automatic Retry
Power and Self-Test Diagnostics
Pressure Switch
Redundant Main Gas Control
Single Speed Option for Heating and Cooling Applications
Solid Bottom
Blower Insulation
Solid State Time On/Off Blower Control
Transformer
Twinning (Built-In) Features

**WARNING**  
THIS FURNACE IS NOT APPROVED  
OR RECOMMENDED  
FOR USE IN MOBILE HOMES

## Physical Data and Specifications U.S. and Canadian Models

MODEL NUMBERS	R951T 0403A17M4SNAS	R951T 0603A17M4SNAS	R951T 0703A17M4SNAS	R951T 0705A21M4SNAS	R951T 0855A21M4SNAS	R951T 1005A21M4SNAS	R951T 1155A24M4SNAS
HIGH FIRE INPUT BTU/HR [kW] ①	42,000 [12.30]	56,000 [16.41]	70,000 [20.51]	70,000 [20.51]	84,000 [24.61]	98,000 [28.72]	112,000 [32.82]
HEATING CAPACITY BTU/HR [kW]	39,900 [11.69]	53,200 [15.59]	66,500 [19.49]	66,500 [19.49]	79,800 [23.39]	93,100 [27.28]	106,400 [31.18]
HIGH ALTITUDE OUTPUT 10% DERATE [kW] ②	35,910 [10.52]	47,880 [14.03]	59,850 [17.54]	59,850 [17.54]	71,820 [21.05]	83,790 [24.56]	95,760 [28.06]
BLOWER (D x W) [mm]	11 x 7 [279 x 178]	11 x 8 [279 x 203]	11 x 8 [279 x 203]	11 x 10 [279 x 254]	11 x 10 [279 x 254]	11 x 10 [279 x 254]	11 x 11 [279 x 279]
MOTOR H.P. [W]– TYPE	1/2 [373] 5 Spd Constant Torque	1/2 [373] 5 Spd Constant Torque	1/2 [373] 5 Spd Constant Torque	1 [746] 5 Spd Constant Torque	1 [746] 5 Spd Constant Torque	1 [746] 5 Spd Constant Torque	1 [746] 5 Spd Constant Torque
MIN. CIRCUIT AMPACITY	8.00	10.00	10.00	12.00	13.00	15.00	14.00
MIN. OVERLOAD PROTECTION DEVICE	15.00	15.00	15.00	15.00	20.00	20.00	20.00
MAX. OVERLOAD PROTECTION DEVICE	15.00	15.00	15.00	20.00	20.00	20.00	20.00
MOTOR FULL LOAD AMPS	6.1	6.1	6.1	12.4	12.4	12.4	12.4
MAXIMUM EXT. STATIC PRESSURE (IN. W.C.) [kPa]	.9 [0.224]	.9 [0.224]	.9 [0.224]	.9 [0.224]	.9 [0.224]	.9 [0.224]	.9 [0.224]
HEATING CFM [L/s]	MED-LOW	MED-LOW	MED	MED-LOW	MED-LOW	MED-LOW	MED
COOLING CFM [L/s]	HIGH	HIGH	HIGH	HIGH	HIGH	HIGH	HIGH
TEMPERATURE RISE- HIGH FIRE RANGE IN DEGREES °F [°C]	25 - 55 [14 - 31]	35 - 65 [19 - 36]	40 - 70 [22 - 39]	30 - 60 [17 - 33]	35 - 65 [19 - 36]	40 - 70 [22 - 39]	45 - 75 [25 - 42]
APPROX. SHIPPING WEIGHT (LBS.) [kg]	123 [56]	128 [58]	133.5 [61]	146.5 [66]	150 [68]	155 [70]	190 [86.2]
AFUE ③	95.00%	95.00%	95.00%	95.00%	95.00%	95.00%	95.00%

NOTES: All models are 115V, 60HZ, 1 phase Gas connection size for all models is 1/2" [13 mm] N.P.T.

① Installation instructions for high altitude derate.

② Canadian installations only.

③ In accordance with D.O.E. test procedures.

NOTE: Standard model complies with California low NOx requirements up to 40ng/J.

This furnace does not meet air district requirements of 14 ng/J NOx emissions limit, and thus is subject to a mitigation fee of up to \$450.

This furnace is to be installed for propane firing only in air districts requiring 14 ng/J NOx emission limits. Operating in natural gas mode is in violation of these Rules.

[ ] Designates Metric Conversions

## Upflow Application

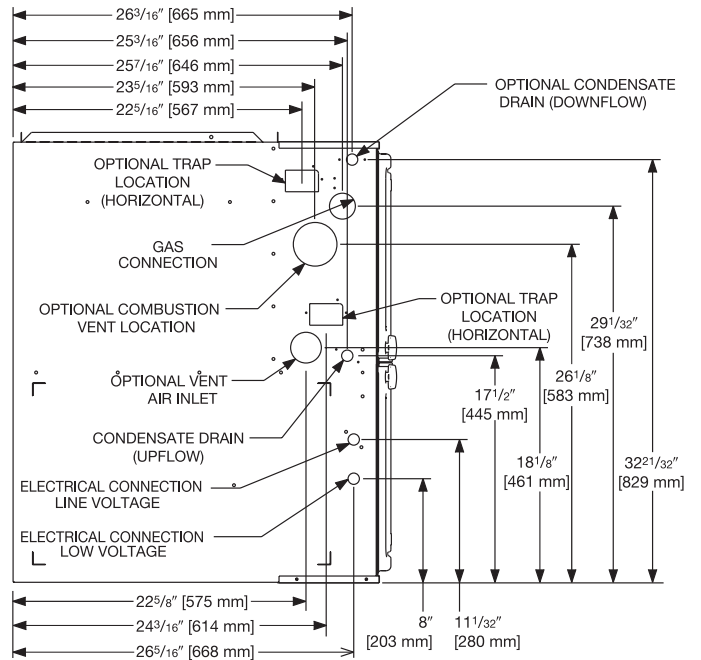
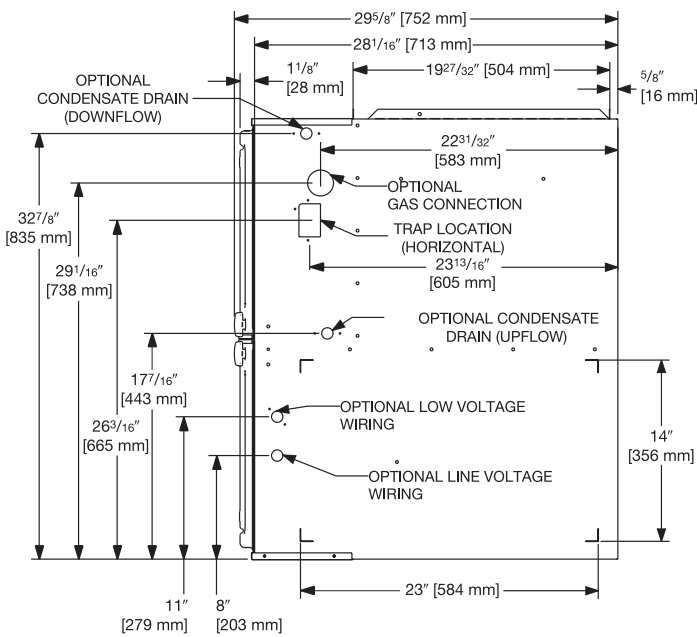
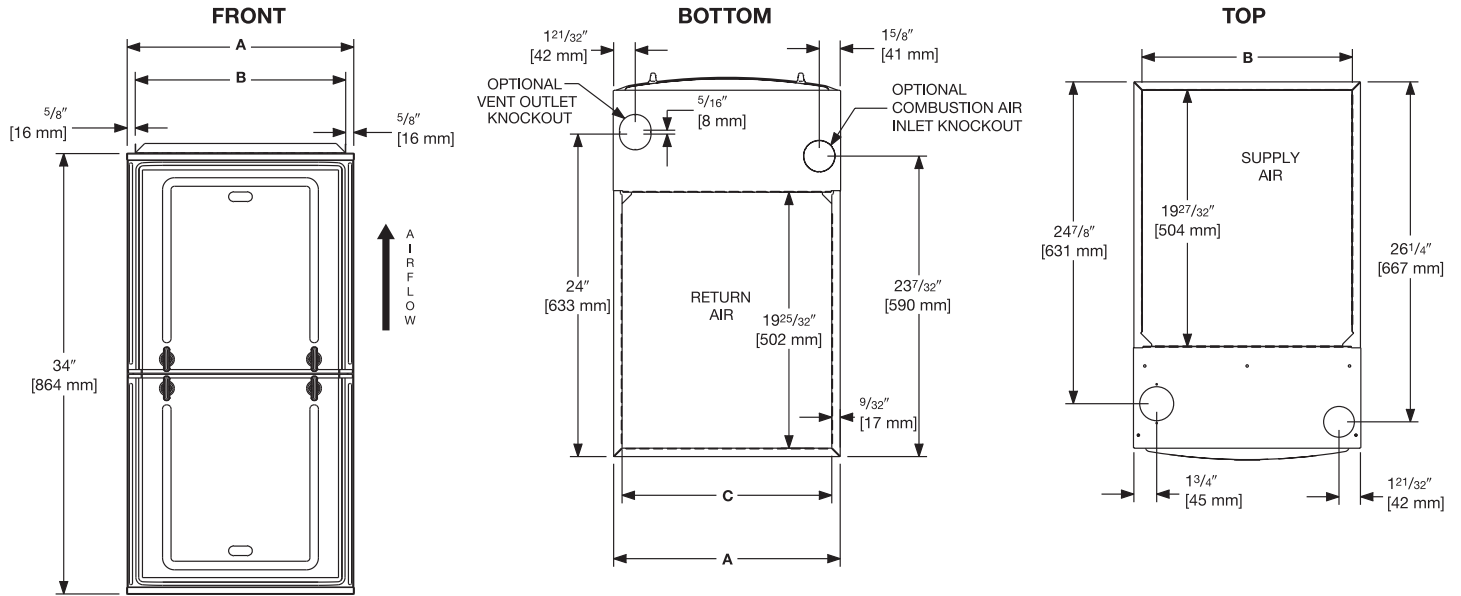

RIGHT SIDE

LEFT SIDE

## Dimensional Data: Upflow Model

MODEL R951T	LEFT SIDE	MINIMUM CLEARANCE (IN.) [mm]					SHIP WGTS.	FLANGE DIMENSIONS		
		RIGHT SIDE	BACK	TOP	FRONT	VENT		A	B	C
040	0	0	0	1 [25]	2 [51]	0	123.5 [56]	17 1/2 [445]	16 17/64 [413]	16 13/64 [412]
060	0	0	0	1 [25]	2 [51]	0	128 [58]	17 1/2 [445]	16 17/64 [413]	16 13/64 [412]
070	0	0	0	1 [25]	2 [51]	0	132 [60]	17 1/2 [445]	16 17/64 [413]	16 13/64 [412]
070 (wide)	0	0	0	1 [25]	2 [51]	0	147.5 [67]	21 [533]	19 49/64 [502]	19 45/64 [500]
085	0	0	0	1 [25]	2 [51]	0	147.5 [67]	21 [533]	19 49/64 [502]	19 45/64 [500]
100	0	0	0	1 [25]	2 [51]	0	152 [69]	21 [533]	19 49/64 [502]	19 45/64 [500]
115	0	0	0	1 [25]	2 [51]	0	165 [75]	24 1/2 [662]	23 17/64 [591]	23 13/64 [589]

\*A service clearance of at least 24" is recommended in front of all furnaces  
 Supply and return depicted as upflow configuration.  
 Flange configuration will vary depending on installation orientation.

[ ] Designates Metric Conversions

## Blower Performance Data

AIR FLOW PERFORMANCE - 95% SINGLE STAGE CONSTANT TORQUE												
INPUT [BTU] CABINET WIDTH [IN]	AIRFLOW CONTROL SETTINGS	SPEED TAP/ WIRE COLORS	CFM AIR DELIVERY									
			0.1	0.2	0.3	0.4	0.5	0.6	0.7	0.8	0.9	1.0
40K 17"	Factory Setting Fan	Low/Red	807	765	717	666	612	557	502	448	396	349
	Heat or Heat/Cool	Medium Low/Yellow	965	921	874	824	771	716	659	601	543	484
	Cool	Medium/Purple	1076	1035	994	953	910	864	813	758	697	630
	Cool	Medium High/Blue	1150	1108	1068	1030	991	951	908	860	806	745
	Factory Setting Cooling	High/Black	1298	1259	1220	1182	1144	1106	1067	1028	987	945
60K 17"	Factory Setting Fan	Low/Red	998	950	906	853	791	728	676	634	584	542
	Heat or Heat/Cool	Medium Low/Yellow	1060	1016	963	924	862	802	753	706	663	616
	Cool	Medium/Purple	1143	1104	1060	1016	970	930	873	820	769	725
	Cool	Medium High/Blue	1328	1293	1258	1220	1183	1142	1107	1069	1016	960
	Factory Setting Cooling	High/Black	1473	1441	1403	1366	1331	1295	1265	1236	1200	1159
70K 17"	Factory Setting Fan	Low/Red	635	602	564	524	482	440	399	362	329	302
	Cool	Medium Low/Yellow	1080	1035	985	931	874	816	759	704	654	610
	Heat or Heat/Cool	Medium/Purple	1222	1183	1138	1090	1039	985	931	877	824	774
	Cool	Medium High/Blue	1371	1330	1290	1251	1210	1169	1125	1078	1028	972
	Factory Setting Cooling	High/Black	1458	1421	1385	1349	1312	1274	1235	1193	1148	1101
70K 21"	Factory Setting Fan	Low/Red	1154	1105	1046	980	911	841	773	709	653	608
	Heat or Heat/Cool	Medium Low/Yellow	1450	1405	1357	1307	1255	1202	1147	1091	1036	981
	Cool	Medium/Purple	1583	1536	1490	1446	1401	1356	1308	1257	1203	1144
	Cool	Medium High/Blue	1750	1703	1662	1626	1591	1556	1520	1479	1432	1377
	Factory Setting Cooling	High/Black	1981	1931	1894	1865	1835	1797	1745	1671	1568	1428
85K 21"	Factory Setting Fan	Low/Red	1086	1022	931	855	812	734	679	606	559	526
	Heat or Heat/Cool	Medium Low/Yellow	1651	1611	1571	1518	1476	1434	1383	1311	1271	1208
	Cool	Medium /Purple	1755	1712	1670	1626	1596	1531	1490	1445	1421	1337
	Cool	Medium High/Blue	2042	1996	1971	1944	1901	1872	1849	1812	1767	1738
	Factory Setting Cooling	High/Black	2114	2082	2049	2009	1974	1940	1903	1821	1752	1633
100K 21"	Factory Setting Fan	Low/Red	1336	1274	1200	1156	1090	1019	965	916	852	796
	Heat or Heat/Cool	Medium Low/Yellow	1574	1521	14881	1423	1376	1327	1272	1218	1170	1114
	Cool	Medium/Purple	1683	1644	1609	1559	1521	1464	1427	1366	1313	1280
	Cool	Medium High/Blue	1843	1801	1771	1732	1696	1661	1611	1533	1531	1461
	Factory Setting Cooling	High/Black	2063	2018	1992	1943	1914	1875	1837	1807	1768	1726
115K 24"	Factory Setting Fan	Low/Red	1406	1336	1268	1196	1125	1078	1003	942	869	808
	Cool	Medium Low/Yellow	1561	1491	1423	1359	1304	1227	1171	1123	1071	1018
	Heat or Heat/Cool	Medium/Purple	1696	1645	1586	1533	1480	1407	1370	1305	1254	1220
	Cool	Medium High/Blue	1852	1801	1761	1701	1630	1591	1523	1466	1427	1362
	Factory Setting Cooling	High/Black	1996	1951	1890	1840	1799	1741	1666	1612	1602	1534

## Vent Termination Kits: =

**RXGY-E02:** Vertical/Horizontal Concentric Vent Termination Kit  
2" Pipe (US Only)

**RXGY-E02A:** Vertical/Horizontal Concentric Vent Termination Kit  
2" Pipe (US & Canadian)

**RXGY-E03:** Vertical/Horizontal Concentric Vent Termination Kit  
3" Pipe (US Only)

**RXGY-E03A:** Vertical/Horizontal Concentric Vent Termination Kit  
3" Pipe (US & Canadian)

**RXGY-G02:** Direct Vent Furnace Side Wall Vent 2" or 3" (US Only)

**RXGY-D05:** Combustion Air Drain Kit 2"

**RXGY-D06:** Combustion Air Drain Kit 3"

**NEUTRALIZER KIT:** RXGY-A01  
(Replacement Cartridge 54-22120-01)

**EXTERNAL BOTTOM FILTER (UPFLOW/HORIZONTAL) RACK:**  
RXGF-CB

**EXTERNAL SIDE (UPFLOW) FILTER RACK:** RXGF-CD

**EXTERNAL (DOWNFLOW) FILTER RACK:** RXGF-CC

## For High Altitudes:

**NOTE:** For Canadian installations only, an optional derate (manifold gas pressure reduction) method may be used to adjust the furnace for altitude. See Installation Instructions for more information. This optional method may **NOT** be used for U.S. installations. See installation instructions as appropriate orifice change is required.

**L.P. CONVERSION KIT:** RXGJ-FP38

**CONDENSATE PUMP KIT:** PROSTOCK & 1PCB151TUL

**DOWNFLOW/HORIZONTAL CONVERSION KIT:** RXGY-CK

**DOWNFLOW/HORIZONTAL LEFT ZERO CLEARANCE  
CONVERSION KIT:** RXGY-ZK

**COMBUSTIBLE FLOOR BASE:** RXGC-B17  
RXGC-B21  
RXGC-B24

[ ] Designates Metric Conversions

FILTER RACK FILTER SIZES* INCHES [mm]			
MODEL	RXGF-CB (UPFLOW/ HORIZONTAL)	RXGF-CD (UPFLOW)	RXGF-CC (DOWNFLOW)
R91T(-)040	15 <sup>3</sup> / <sub>4</sub> x 25 [400 x 635]	15 <sup>3</sup> / <sub>4</sub> x 25 [400 x 635]	14 x 20 [356 x 508]
R91T(-)060	15 <sup>3</sup> / <sub>4</sub> x 25 [400 x 635]	15 <sup>3</sup> / <sub>4</sub> x 25 [400 x 635]	14 x 20 [356 x 508]
R91T(-)070	15 <sup>3</sup> / <sub>4</sub> x 25 [400 x 635]	15 <sup>3</sup> / <sub>4</sub> x 25 [400 x 635]	14 x 20 [356 x 508]
R91T(-)070 (wide)	19 <sup>1</sup> / <sub>4</sub> x 25 [489 x 635]	15 <sup>3</sup> / <sub>4</sub> x 25 [400 x 635]	12 x 20 [305 x 508]
R91T(-)085	19 <sup>1</sup> / <sub>4</sub> x 25 [489 x 635]	15 <sup>3</sup> / <sub>4</sub> x 25 [400 x 635]	14 x 20 [356 x 508]
R91T(-)100	19 <sup>1</sup> / <sub>4</sub> x 25 [489 x 635]	15 <sup>3</sup> / <sub>4</sub> x 25 [400 x 635]	14 x 20 [356 x 508]
R91T(-)115	22 <sup>3</sup> / <sub>4</sub> x 25 [578 x 635]	15 <sup>3</sup> / <sub>4</sub> x 25 [400 x 635]	14 x 20 [356 x 508]

## Indoor Coil Casings

MODEL NUMBER
RXBC-D17A1
RXBC-D21A1
RXBC-D21B1
RXBC-D24A1











The new degree of comfort®

**GENERAL TERMS OF LIMITED WARRANTY\***

Rheem will furnish a replacement for any part of this product which fails in normal use and service within the applicable period stated, in accordance with the terms of the limited warranty.

**\*For complete details of the Limited and Conditional Warranties, including applicable terms and conditions, contact your local contractor or the Manufacturer for a copy of the product warranty certificate.**

Conditional Parts  
(Registration Required)..... Ten (10) Years  
Heat Exchanger ..... Limited Lifetime

**Before proceeding with installation, refer to installation instructions packaged with each model, as well as complying with all Federal, State, Provincial, and Local codes, regulations, and practices.**

© 2023 Rheem Manufacturing Company. Rheem trademarks owned by Rheem Manufacturing Company.

*In keeping with its policy of continuous progress and product improvement, Rheem reserves the right to make changes without notice.*

Rheem Heating, Cooling & Water Heating • 5600 Old Greenwood Road  
Fort Smith, Arkansas 72908 • [www.rheem.com](http://www.rheem.com)

Rheem Canada Ltd./Ltée • 125 Edgeware Road, Unit 1  
Brampton, Ontario • L6Y 0P5 • [rheem.ca](http://rheem.ca)