



## Vantix™ Line Air Handlers



### RF1PZ

Motor: PSC

Airflow Stages: Single-Stage

Expansion Device: Thermal Expansion Valve (TXV)

Efficiencies: 13.4 to 14.3 SEER2



## Table of Contents

Features & Benefits .....	3
Model Number Identification .....	4
Dimensional Data .....	5
Unit Dimensions & Weights .....	6
Airflow Performance Data .....	7-8
Electrical Data .....	9-10
Limited Warranty .....	12

## Features and Benefits

- **Quiet Operation<sup>1</sup>:** Provided by a cabinet construction with 1.0 inch of foil faced insulation for quieter sound characteristics
- **Front or Bottom Return with Aluminum Indoor Coil Design:** Are constructed of aluminum fins bonded to internally grooved aluminum tubing and are more corrosion resistant
- **Rugged Steel Cabinet Construction:** Designed for added strength and versatility
- **Most Compact Unit Design Available:** All standard air handler models are only 36" [915mm] in height
- **Field-installed Auxiliary Heater Kits:** Provide exact heat for indoor comfort and include circuit breakers which meet UL and cUL requirements for service disconnect
- **Less than 2% Cabinet Air Leakage at 1-inch H<sub>2</sub>O:** When tested in accordance with AHRAE Standard 193

[ ] Designates Metric Conversions

<sup>1</sup>Based on manufacturer's air handler offering, and the product's airflow stages, motor type and cabinet insulation. Sound levels are also dependent on air handler location and installation.

# Air Handlers

<u>R</u>	<u>F</u>	<u>1</u>	<u>P</u>	<u>Z</u>	<u>18</u>	<u>21</u>	<u>S</u>	<u>T</u>	<u>A</u>	<u>N</u>	<u>S</u>	<u>J</u>	<u>B</u>	<u>00</u>	<u>417</u>
Brand	Product Category	Stages Of Airflow	Motor Type	Refrigerant	Capacity	Width	Efficiency	Metering	Major Series	Controls	Coil Series	Voltage	Disconnect	Factory Heat	Option Code
R - Russell® By Rheem	F - Front Return	1 - 1-Stage	P - PSC	Z - R-410A	18 - 18,000 [5.28 kW] 24 - 24,000 [7.03 kW] 30 - 30,000 [8.79 kW] 36 - 36,000 [10.55 kW]	21 - 21" 24 - 24.5"	S - Standard	T - TXV	A - 1st Design	N - Non-Communicating	S - Slab	J - 208-240/1/60	B - Breaker N - None	00 - No Heat 03 - 3 kW 05 - 5 kW 08 - 8 kW 10 - 10 kW	417 - Float Switch

Available Models
RF1PZ1821STANSJB03
RF1PZ1821STANSJB05
RF1PZ1821STANSJB08
RF1PZ1821STANSJN00
RF1PZ2421STANSJB03
RF1PZ2421STANSJB05
RF1PZ2421STANSJB08
RF1PZ2421STANSJB10
RF1PZ2421STANSJN00
RF1PZ3024STANSJB03
RF1PZ3024STANSJB05
RF1PZ3024STANSJB08
RF1PZ3024STANSJB10
RF1PZ3024STANSJN00
RF1PZ3624STANSJB03
RF1PZ3624STANSJB05
RF1PZ3624STANSJB08
RF1PZ3624STANSJB10
RF1PZ3624STANSJN00

Standard Equipment
The most compact unit design available, all standard heat air handler models only 36" [915 mm]
Rugged wall steel cabinet construction, designed for added strength and versatility
1.0" foil faced insulation for excellent thermal and sound performance
Four leg blower motor mount
Traditional open wire element design for heat applications
Indoor coil design provides low air side pressure drop, high performance and extremely compact size
Coils are constructed of aluminum fins and internally grooved aluminum tubing
Molded polymer corrosion resistant condensate drain pan is provided for all indoor coils
Connection point for high voltage wiring is inside the air handler cabinet. Low voltage connection is made on the outside of the air handler cabinet
Concentric knockouts are provided for power connection to cabinet. Installer may pull desired hole size up to 1-3/8 inches [35 mm] for 7/8 inch [22 mm] conduit

[ ] Designates Metric Conversions

# Unit Dimensions

NOTE: 24" [610 mm] CLEARANCE REQUIRED IN FRONT OF UNIT FOR FILTER AND COIL MAINTENANCE

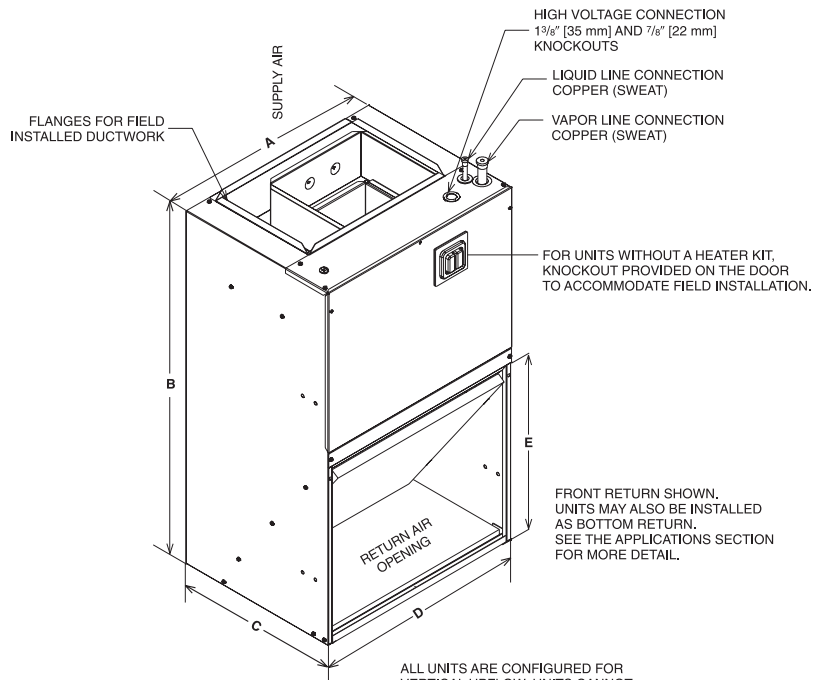

FRONT RETURN SHOWN. UNITS MAY ALSO BE INSTALLED AS BOTTOM RETURN. SEE THE APPLICATIONS SECTION FOR MORE DETAIL.

ALL UNITS ARE CONFIGURED FOR VERTICAL UPFLOW. UNITS CANNOT BE INSTALLED IN ANY OTHER CONFIGURATION.

## Return Air Opening Dimensions

Model Cabinet Size	Return Air Opening Width (Inches)	Return Air Opening Depth/Length (Inches)
17	15 <sup>7</sup> / <sub>8</sub>	19 <sup>3</sup> / <sub>4</sub>
21	19 <sup>3</sup> / <sub>8</sub>	19 <sup>3</sup> / <sub>4</sub>
24	22 <sup>7</sup> / <sub>8</sub>	19 <sup>3</sup> / <sub>4</sub>

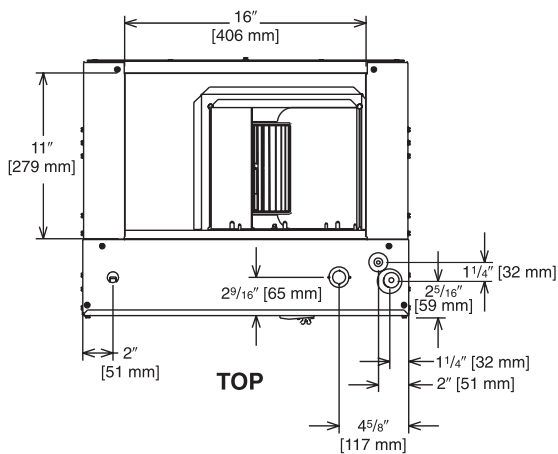

**TOP**

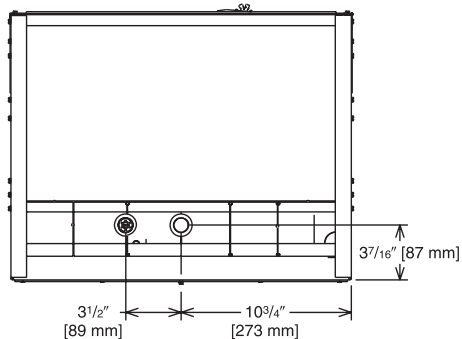

**BOTTOM**

**1 1/2 & 2 TON [5.28 & 7.03 kW] MODELS**

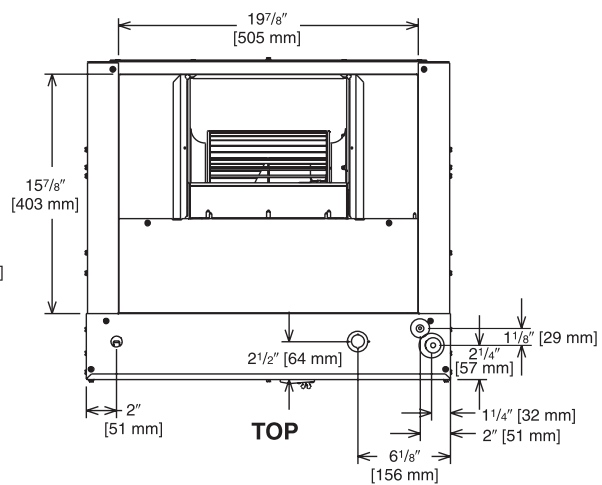

**TOP**

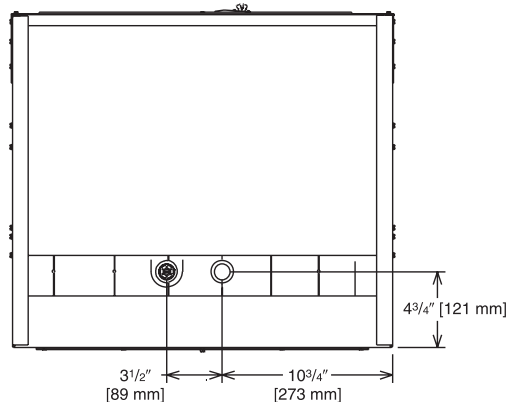

**BOTTOM**

**2 1/2 & 3 TON [8.79 & 10.6 kW] MODELS**

## Unit Dimensions & Weights

Model	(A) Unit Width In. [mm]	(B) Unit Height In. [mm]	(C) Unit Depth In. [mm]	(D) Return Air Opening Width In. [mm]	(E) Return Air Opening Height In. [mm]	Filter Size in. x in. x in. [mm x mm x mm]	Air Flow CFM (Nom.) [L/s]		Unit Weight/ Shipping Weight (Lbs.) [kg]
							Low	High	
RF1PZ1821	21½ [546.1]	36 [914.4]	17 [431.8]	20 [508.0]	17 <sup>7</sup> / <sub>16</sub> [442.9]	20 X 20 X 1 [508 X 508 X 25.4]	600 [283]	—	80 [36] / 90 [41]
RF1PZ2421	21½ [546.1]	36 [914.4]	17 [431.8]	20 [508.0]	17 <sup>7</sup> / <sub>16</sub> [442.9]	20 X 20 X 1 [508 X 508 X 25.4]	800 [378]	—	80 [36] / 90 [41]
RF1PZ3024	24 [609.6]	36 [914.4]	21 [533.4]	23 [584.2]	21 <sup>3</sup> / <sub>8</sub> [542.9]	20 X 25 X 1 [508 X 635 X 25.4]	1000 [472]	—	95 [43] x 105 [48]
RF1PZ3624	24 [609.6]	36 [914.4]	21 [533.4]	23 [584.2]	21 <sup>3</sup> / <sub>8</sub> [542.9]	20 X 25 X 1 [508 X 635 X 25.4]	1200 [566]	—	95 [43] x 105 [48]

[ ] Designates Metric Conversions

## Airflow Performance

**Airflow performance data is based on cooling performance with a coil and no filter in place.** Select performance table for appropriate unit size, voltage and number of electric heaters to be used. Make sure external static applied to unit allows operation within the minimum and maximum limits shown in

table below for both cooling and electric heat operation. For optimum blower performance, operate the unit in the .3 [8 mm] to .7 inches [18 mm] W.C. external static range. Units with coils should be applied with a minimum of .1 inch [3 mm] W.C. external static range.

## Airflow Operating Limits

Model Cabinet Size	21		24	
Cooling BTUH x 1,000 Cooling Tons Nominal	-18 1.5	-24 2	-30 2.5	-36 3
Heat Pump or Air Conditioning Maximum Heat/Cool CFM [L/s] (37.5 CFM [18 L/s]/1,000 BTUH) (450 CFM [212 L/s]/Ton Nominal)	675 [319]	900 [425]	1125 [531]	1350 [637]
Heat Pump or Air Conditioning Nominal Heat/Cool CFM [L/s] (33.3 CFM [16 L/s]/1,000 BTUH) (400 CFM [189 L/s]/Ton Nominal)	600 [283]	800 [378]	1000 [472]	1200 [566]
Heat Pump or Air Conditioning Minimum Heat/Cool CFM [L/s] (30.0 CFM [14 L/s]/1,255 BTUH) (360 CFM [170 L/s]/Ton Nominal)	540 [255]	720 [340]	900 [425]	1080 [510]
Maximum kW Electric Heating & Minimum Electric Heat CFM [L/s]	8 450 [212]	10 690 [326]	10 808 [381]	10 976 [461]
Maximum Electric Heat Rise °F [°C]	54 [12]	44 [7]	44 [7]	44 [7]

[ ] Designates Metric Conversions

## Airflow Performance Data – (-)F1PZ (PSC Motor)

Model/ Nominal Cooling Capacity	Manufacturer Recommended Airflow Range (Max./Min.) CFM	Blower Size/ Motor HP # of Speeds	Motor Speed From Factory	Motor Speed	PSC							
					CFM Dry Delivery/filter/heaters/RPM/Watts							
					External Static Pressure-Inches W.C.							
						0.10	0.20	0.30	0.40	0.50	0.60	0.70
(-)F1PZ18 1.5 Tons	873/438	10x6 1/5 Hp 2 speed dual voltage	High	High	CFM	873	828	785	751	707	—	—
					RPM	897	923	948	955	981	—	—
					Watts	288	286	283	280	274	—	—
				Low	CFM	572	543	508	477	438	—	—
					RPM	706	753	791	830	869	—	—
					Watts	184	181	187	178	172	—	—
(-)F1PZ24 2 Tons	1137/764	10x6 1/5 Hp 2 speed dual voltage	High	High	CFM	1137	1097	1034	985	933	868	810
					RPM	1101	1104	1114	1118	1124	1130	1136
					Watts	438	444	446	421	391	377	360
				Low	CFM	867	855	827	798	764	—	—
					RPM	864	902	948	978	1002	—	—
					Watts	324	317	290	285	283	—	—
(-)F1 PZ30 2.5 Tons	1148/802	10x8T 1/4 Hp 2 speed dual voltage	High	High	CFM	1363	1303	1240	1169	1096	1030	—
					RPM	1029	1047	1060	1082	1095	1104	—
					Watts	515	514	468	428	428	394	—
				Low	CFM	1196	1158	1105	1048	—	—	—
					RPM	958	984	1012	1037	—	—	—
					Watts	423	402	402	360	—	—	—
(-)F1 PZ36 3 Tons	1363/1048	10x8T 1/3 Hp 2 speed dual voltage	High	High	CFM	1523	1447	1375	1293	1209	1121	1037
					RPM	1081	1085	1090	1096	1102	1107	1113
					Watts	680	658	640	621	603	588	571
				Low	CFM	1333	1272	1201	1133	1060	979	888
					RPM	970	988	1003	1020	1064	1048	1064
					Watts	442	427	409	392	376	360	336

[ ] Designates Metric Conversions



## Electrical Data – Blower Motor Only – No Electric Heat RF1PZ

Model/Nominal Cooling Tons	Voltage	Phase	Hertz	HP [W]	RPM	Speeds	Circuit Amps.	Minimum Circuit Ampacity	Maximum Circuit Protector
RF1PZ1821	208/230	1	60	1/5 [149]	1075	2	1.9	3	15
RF1PZ2421	208/230	1	60	1/4 [149]	1075	2	1.9	3	15
RF1PZ3024	208/230	1	60	1/3 [249]	1075	2	2.7	4	15
RF1PZ3624	208/230	1	60	1/2 [373]	1075	2	2.7	4	15

\*Blower motors are all single phase motors.

## RF1PZ Electrical Data – with Electric Heat

Installation of the U.L. Listed original equipment manufacturer provided heater kits listed in the table below is recommended for all auxiliary heating requirements.

Cooling Capacity Tons	Model No.	Heater kW	PH/Hz	No. Elements - kW Per	(208/240V) Type Supply Circuit	Circuit Amps.	Motor Ampacity	Minimum Circuit Ampacity	Maximum Circuit Protection
RF1PZ18	RXHJ-21B/T03J-1	2.25/3.0	1/60	1-3.0	Single	10.8/12.5	1.9	16/18	20/20
	RXHJ-21B/T05J	3.6/4.8	1/60	1-4.8	Single	17.3/20.0	1.9	0.9	25/30
	RXHJ-21B/T08J	5.4/7.2	1/60	2-3.6	Single	26.0/30.0	1.9	35/40	35/40
RF1PZ24	RXHJ-21B/T03J	2.25/3.0	1/60	1-3.0	Single	10.8/12.5	1.9	16/18	20/20
	RXHJ-21B/T05J	3.6/4.8	1/60	1-4.8	Single	17.3/20.0	1.9	0.9	25/30
	RXHJ-21B/T08J	5.4/7.2	1/60	2-3.6	Single	26.0/30.0	1.9	35/40	35/40
	RXHJ-21B/T10J	7.2/9.6	1/60	2-4.8	Single	34.6/40.0	1.9	0.9	50/60
RF1PZ30	RXHJ-24B/T03J	2.25/3.0	1/60	1-3.0	Single	10.8/12.5	2.7	17/19	20/20
	RXHJ-24B/T05J	3.6/4.8	1/60	1-4.8	Single	17.3/20.0	2.7	25/29	25/30
	RXHJ-24B/T08J	5.4/7.2	1/60	2-3.6	Single	26.0/30.0	2.7	36/41	40/45
	RXHJ-24B/T10J	7.2/9.6	1/60	2-4.8	Single	34.6/40.0	2.7	47/54	50/60
RF1PZ36	RXHJ-24B/T03J	2.25/3.0	1/60	1-3.0	Single	10.8/12.5	2.7	17/19	20/20
	RXHJ-24B/T05J	3.6/4.8	1/60	1-4.8	Single	17.3/20.0	2.7	25/29	25/30
	RXHJ-24B/T08J	5.4/7.2	1/60	2-3.6	Single	26.0/30.0	2.7	36/41	40/45
	RXHJ-24B/T10J	7.2/9.6	1/60	2-4.8	Single	34.6/40.0	2.7	47/54	50/60

- Electric heater BTUH - (heater watts + motor watts) x 3.414 (see airflow table for motor watts.)
- J voltage (230V) single phase air handler is designed to be used with single or three phase.
- Supply circuit protective devices may be fused or "HACR" type circuit breakers.
- If non-standard fuse size is specified, use next size larger standard fuse size. Without the heater, bring only two leads to terminal block, cap, insulate and fully secure the third lead.
- Largest motor load is included in single circuit or circuit 1 of multiple circuits.
- Do not use 480 volts electrical heaters on 230 volts air handler.
- No electrical heating elements are permitted to be used with A Voltage (115V) air handler.

### Electrical Wiring: Power Wiring Grounding

- Field wiring must comply with the National Electrical Code
- This product must be sufficiently grounded in accordance with (C.E.C. in Canada) and any applicable local ordinance. National Electrical Code (C.E.C. in Canada) and any applicable
- Supply wiring must be 75°C minimum copper conductors only. Local ordinance.
- See electrical data for product Ampacity rating and Circuit.
- A grounding lug is provided. Protector requirement.

[ ] Designates Metric Conversions

## 16.0 Accessories-Kits-Parts

- **Drain Pan Over Flow Switch RXHK-A01** is used to detect condensate drain blockage and will shut down the outdoor unit in order to prevent structural damage to the surrounding structures of the air handler.

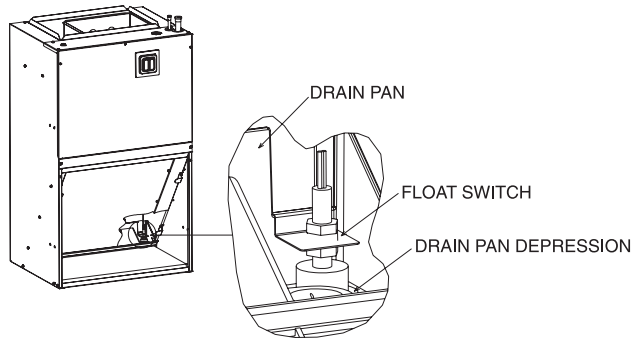

- **Bottom Return Conversion Kit RXHK-** is used to divert the return air from the factory standard front return to a bottom return.

Accessory Number	Indoor Unit
RXHK-B01	RF1PZ-FR18
	RF1PZ-FR24
RXHK-B02	RF1PZ-FR30
	RF1PZ-FR36

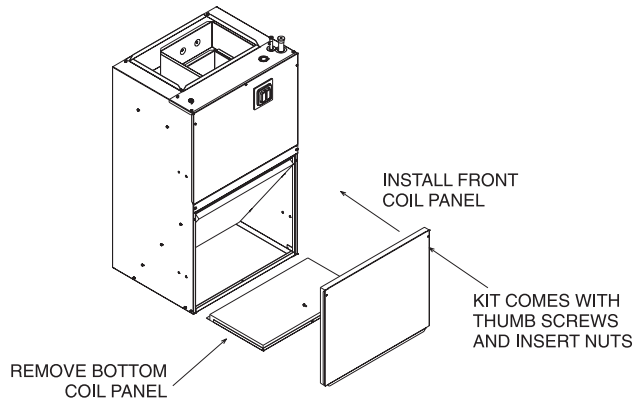

- **Louvered Cabinet Grill RXHK-** is used as decorative grill which covers the return air opening of the front return air handler.

Accessory Number	Indoor Unit
RXHK-C01	RF1PZ-FR18
	RF1PZ-FR24
RXHK-C02	RF1PZ-FR30
	RF1PZ-FR36

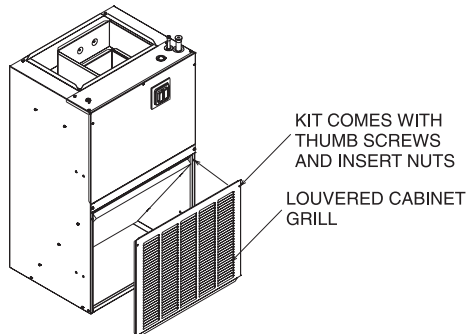

- **Decorative Wall Grill RXHK-D01** or **RXHK-D02** is used in applications where the air handler is installed in a closet or interior wall and allows adequate return air back to the unit. Please refer to RXHD-D01/RXHK-D02 installation instructions for complete dimensional information when selecting a decorative wall grill.

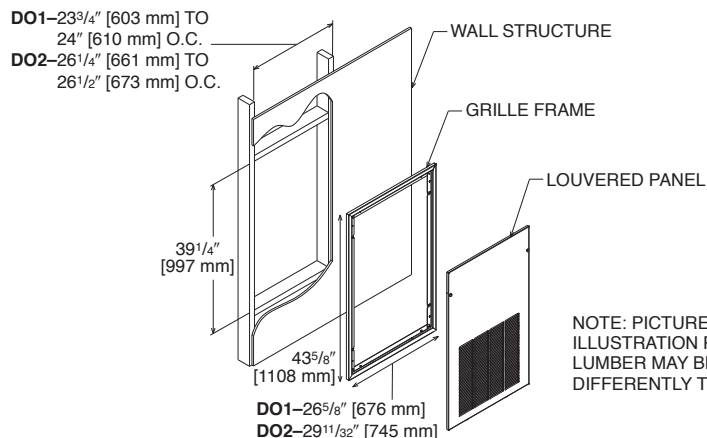

NOTE: PICTURE IS FOR ILLUSTRATION PURPOSES ONLY, LUMBER MAY BE ORIENTED DIFFERENTLY THAN SHOWN.

[ ] Designates Metric Conversions





**GENERAL TERMS OF LIMITED WARRANTY\***

Russell® By Rheem will furnish a replacement for any part of this product which fails in normal use and service within the applicable periods stated, in accordance with the terms of the limited warranty.

Conditional Parts  
(Registration Required)..... Ten (10) Years

**\*For complete details of the Limited and Conditional Warranties, including applicable terms and conditions, contact your local contractor or the Manufacturer for a copy of the product warranty certificate.**

**Before proceeding with installation, refer to installation instructions packaged with each model, as well as complying with all Federal, State, Provincial, and Local codes, regulations, and practices.**

*In keeping with its policy of continuous progress and product improvement, Russell by Rheem reserves the right to make changes without notice.*

Russell by Rheem • 5600 Old Greenwood Road  
Fort Smith, Arkansas 72908 • [www.russellbyrheem.com](http://www.russellbyrheem.com)