



PROJECT NAME _____
 LOCATION _____
 ARCHITECT _____
 ENGINEER _____
 CONTRACTOR _____
 SUBMITTED BY _____ DATE _____

UNIT SUMMARY

Quantity						
Unit Designation						
Model No.						
Total Cooling						
Sensible Cooling						
Air Ent. Evaporator						
Air Lvg. Evaporator						
Heating Input						
Heating Output						
CFM/ESP						
EER/SEER						
Electrical						
Minimum Ampacity						
Min.-Max. Breaker						
Net Unit Weight						
Accessory						
Catalog Form Number						

ACCESSORIES:

NOTES:

Endeavor® Line (-)P14AZ iM Heat Pumps

Cooling Efficiencies up to: 14.3 SEER2/10.4 EER2

Heating Efficiencies up to: 7.6 HSPF2

Nominal Sizes: 1.5 to 5 Ton [5.3 to 17.6 kW]

JOB NAME _____ LOCATION _____

CONTRACTOR _____ ORDER NO. _____

ENGINEER _____ UNIT MODEL NO. _____

SUBMITTED FOR APPROVAL RECORD COIL MODEL NO. _____

DATE _____ AIR HANDLER MODEL NO. _____

UNIT DATA

COOLING PERFORMANCE

EFFICIENCY SEER

TOTAL CAPACITY* MBH [kW]

SENSIBLE CAPACITY* MBH [kW]

OUTDOOR DESIGN TEMP..... °F [°C] DB

TEMP. OF AIR ENTERING
EVAPORATOR COIL °F [°C] DB

..... °F [°C] WB

POWER INPUT REQUIREMENT kW
(*uses blower motor heat)

HEATING PERFORMANCE

EFFICIENCY HSPF

TOTAL CAPACITY* MBH [kW]

OUTDOOR DESIGN TEMP..... °F [°C] DB

TEMP. OF AIR ENTERING
EVAPORATOR COIL °F [°C] DB

SUPPLY AIR BLOWER PERFORMANCE

TOTAL AIR SUPPLY..... CFM [L/s]

TOTAL RESISTANCE EXTERNAL
TO UNIT IWG

BLOWER SPEED..... RPM

POWER OUTPUT REQUIREMENT BHP

MOTOR RATING HP [W]

POWER INPUT REQUIREMENT kW

ELECTRICAL DATA

POWER SUPPLY Hz

TOTAL UNIT AMPACITY..... AMPS

MINIMUM WIRE SIZE AWG

MAXIMUM OVERCURRENT DEVICE
FUSES/HACR BREAKER AMPS

CLEARANCES

ACCESS SIDE 24" [609.6 mm]

AIR INLETS 12" [304.8 mm]

ABOVE UNIT 60" [1524 mm]

FEATURES

- **Swept Wing Fan Technology¹:** Features quieter operation and improved unit acoustics
- **Two-Stage Scroll Compressor²:** Features two speeds (high and low) of cooling and heating, providing more precise temperature control, lower humidity and greater efficiency when compared to single stage compressors
- **Inverted Reversing Valve:** Allows for faster heat transfer with gravity assist shifting and reduced joint stress for increased reliability
- **PlusOne® Expanded Valve Space:** 3 in. – 4 in. – 5 in. service valve space—provides a minimum working area of 27-square inches for easier access
- **PlusOne® Triple Service Access:** 15 in. wide, industry leading corner service access, two fastener, removeable corner and individual louver panels—makes repairs easier and faster

ACCESSORIES/OPTIONS

- Compressor Crankcase Heater.....
- Low Ambient Control.....
- Compressor Sound Cover.....
- Compressor Hard Start Kit.....
- Low Pressure Control.....
- High Pressure Control.....
- Classic Top Cap w/Label (91-101123-21).....
- Liquid Line Solenoid (24 VAC, 50/60 Hz).....
- Liquid Line Solenoid (120/240 VAC, 50/60 Hz).....

¹Does not apply to the 3.5 and 4 Ton

²Does not apply to the 1.5 Ton 1-stage model



(-)P14AZ

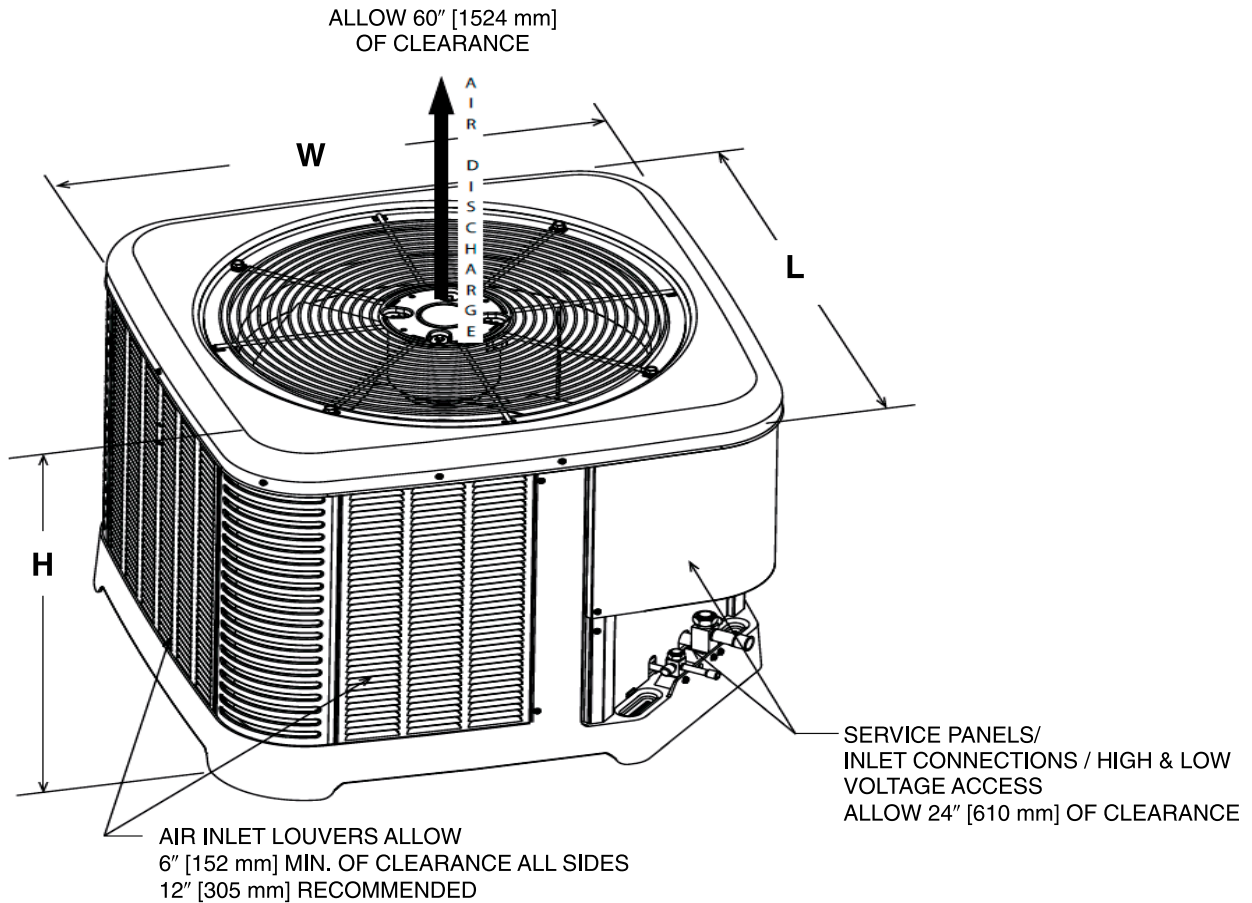

ST-A1226-02-00

Unit Dimensions

MODEL NO.	OPERATING						SHIPPING					
	H (Height)		L (Length)		W (Width)		H (Height)		L (Length)		W (Width)	
	INCHES	mm	INCHES	mm	INCHES	mm	INCHES	mm	INCHES	mm	INCHES	mm
(-)P14AZ18**1	25.00	635	29.75	756	29.75	756	27.90	709	33.25	845	33.25	845
(-)P14AZ18**2	25.00	635	29.75	756	29.75	756	27.90	709	33.25	845	33.25	845
(-)P14AZ24	25.00	635	29.75	756	29.75	756	27.90	709	33.25	845	33.25	845
(-)P14AZ30	27.00	686	33.75	857	33.75	857	30.08	764	37.64	956	37.64	956
(-)P14AZ36	35.00	889	33.75	857	33.75	857	38.35	974	37.64	956	37.64	956
(-)P14AZ42	35.00	889	33.75	857	33.75	857	38.35	974	37.64	956	37.64	956
(-)P14AZ48	35.00	889	33.75	857	33.75	857	38.35	974	37.64	956	37.64	956
(-)P14AZ60	45.00	1143	35.75	908	35.75	908	48.50	1232	39.37	1000	39.37	1000

[] Designates Metric Conversions

Before proceeding with installation, refer to installation instructions packaged with each model, as well as complying with all Federal, State, Provincial, and Local codes, regulations, and practices.

Rheem Sales Company, Inc.
5600 Old Greenwood Road
Fort Smith, Arkansas 72908

© 2023 Rheem Manufacturing Company. Rheem and Ruud trademarks owned by Rheem Manufacturing Company.

"In keeping with its policy of continuous progress and product improvement, Rheem reserves the right to make changes without notice."