



Endeavor[®] Line Air Handlers



RH1PY

PSC Motor

Single-Stage Airflow

Efficiencies: 13.4 to 15.2 SEER2

Refrigerant Type: R-454B



Table of Contents

Features & Benefits	3
Model Number Identification	4
Dimensional Data	5
Unit Dimensions & Weights	6
Airflow Directional Data	7
Airflow Performance Data	8-10
Electrical Data	11-15
Limited Warranty	16

Features and Benefits

- **Quiet Operation¹:** Provided by a cabinet construction with 1.0 inch of foil faced insulation for quieter sound characteristics
- **Aluminum Indoor Coil Design:** Are constructed of aluminum fins bonded to internally grooved aluminum tubing and are more corrosion resistant
- **Versatile 4-Way Convertible Compact Design:** Allows for upflow, downflow, horizontal left and horizontal right applications, even in the smallest of spaces
- **Rugged Steel, Compact Cabinet Construction:** Designed for added strength and versatility
- **Field-installed Auxiliary Heater Kits:** Provide exact heat for indoor comfort and include circuit breakers which meet UL and cUL requirements for service disconnect
- **Cabinet air leakage less than 2% at 1 inch H₂O** when tested in accordance with ASHRAE Standard 193
- **Designing for Sustainability with Low GWP:** For 2025, the Environmental Protection Agency (EPA) has set a global warming potential (GWP) limit of 700 for refrigerant used in heating and cooling systems. This new requirement will result in a 78%² lower GWP than previous-generation refrigerants — with only minimal changes to system installation. For us, this is another step toward our continued sustainability goal of reducing greenhouse gas emissions, while still delivering an exceptional level of energy efficient, dependable comfort
- **PlusOne® Refrigerant Detection System^{TM3}:** An integrated one-box, patented design featuring the A2L sensor and mitigation board, offering easier commissioning with a single component and simplified wiring configuration, compatibility with any 24V thermostat application and system protection by automatically pausing outdoor unit operation — if excess refrigerant is detected

[] Designates Metric Conversions

¹Based on manufacturer's air handler offering, and the product's airflow stages, motor type and cabinet insulation. Sound levels are also dependent on air handler location and installation

²When comparing the GWP of R-454B to R-410A refrigerant

³Factory or field installed in the furnace coil or air handler and is applicable to the complete heating and cooling system featuring Low GWP Refrigerant (A2L)

Air Handlers

<u>R</u>	<u>H</u>	<u>1</u>	<u>P</u>	<u>Y</u>	<u>18</u>	<u>17</u>	<u>S</u>	<u>T</u>	<u>A</u>	<u>N</u>	<u>N</u>	<u>A</u>	<u>L</u>
Brand	Product Category	Stages Of Airflow	Motor Type	Refrigerant	Capacity	Width	Efficiency	Metering	Major Series	Controls	Coil Series	Voltage	Sensor
R - Ruud	H - Multipoise Air Handler	1 - 1-Stage	P - PSC	Y - R-454B	18 - 18,000 [5.28 kW] 24 - 24,000 [7.03 kW] 30 - 30,000 [8.79 kW] 36 - 36,000 [10.55 kW] 42 - 42,000 [12.31 kW] 48 - 48,000 [14.07 kW] 60 - 60,000 [17.58 kW]	17 - 17.5" 21 - 21" 24 - 24.5"	S - Standard	T - TXV	A - 1st Design	N - Non-Communicating	N - N-Coil	A - 115/1/60 J - 208-240/1/60	BLANK - Factory Installed L - Less A2L Sensor

Available Models

RH1PY1817STANNJ	RH1PY4221STANNJL	RH1PY3017STANNA
RH1PY1817STANNJL	RH1PY4821STANNJ	RH1PY3017STANNAL
RH1PY2417STANNJ	RH1PY4824STANNJ	RH1PY3617STANNA
RH1PY2417STANNJL	RH1PY4821STANNJL	RH1PY3621STANNA
RH1PY3017STANNJ	RH1PY4824STANNJL	RH1PY3617STANNAL
RH1PY3017STANNJL	RH1PY6024STANNJ	RH1PY3621STANNAL
RH1PY3617STANNJ	RH1PY6024STANNJL	RH1PY4221STANNA
RH1PY3621STANNJ	RH1PY1817STANNA	RH1PY4221STANNAL
RH1PY3617STANNJL	RH1PY1817STANNAL	RH1PY4821STANNA
RH1PY3621STANNJL	RH1PY2417STANNA	RH1PY4821STANNAL
RH1PY4221STANNJ	RH1PY2417STANNAL	

Standard Equipment

The most compact unit design available, all standard heat air handler models only 42-1/2 to 55-1/2 inches [1079 to 1409 mm] high
Attractive pre-painted cabinet exterior
Rugged wall steel cabinet construction, designed for added strength and versatility
1.0" foil faced insulation mechanically retained in blower compartment for excellent thermal and sound performance
Four leg blower motor mount
Blower housing with controls, motor and blower. Slide out design for service and maintenance convenience
Traditional open wire element design for heat applications
Field convertible for vertical downflow, horizontal left hand or right hand air supply
3 combustible floor base accessories fit all model sizes when required for downflow installations on combustible floors
Indoor coil design provides low air side pressure drop, high performance and extremely compact size
Expansion valve on indoor coil provides for operation with air conditioning
Coils are constructed of aluminum fins bonded to internally grooved aluminum tubing
Coils are tested at the factory with an extensive refrigerant leak check
Coils have copper sweat refrigerant connections
Coils utilize chatleff metering device connections
Molded polymer corrosion resistant condensate drain pan is provided on all indoor coils
Supply duct flanges provided as standard on air handler cabinet
Provisions for field electrical, connections available from either side or top of the air handler cabinet
Connection point for high voltage wiring is inside the air handler cabinet. Low voltage connection is made on the outside of the air handler cabinet
Concentric knockouts are provided for power connection to cabinet. Installer may pull desired hole size up to 2 inches [51 mm] for 1-1/2 inch [38 mm] conduit
Front refrigerant and drain connections

[] Designates Metric Conversions

Unit Dimensions

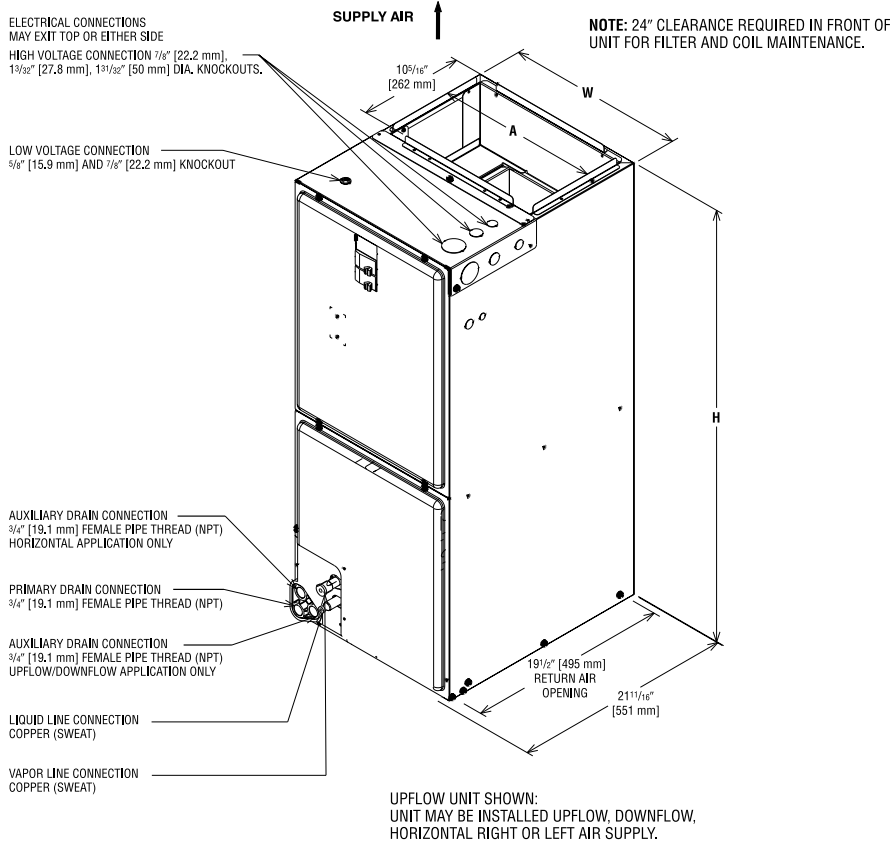

Return Air Opening Dimensions

Model Cabinet Size	Return Air Opening Width (Inches)	Return Air Opening Depth/Length (Inches)
17	15 $\frac{7}{8}$	19 $\frac{3}{4}$
21	19 $\frac{3}{8}$	19 $\frac{3}{4}$
24	22 $\frac{7}{8}$	19 $\frac{3}{4}$

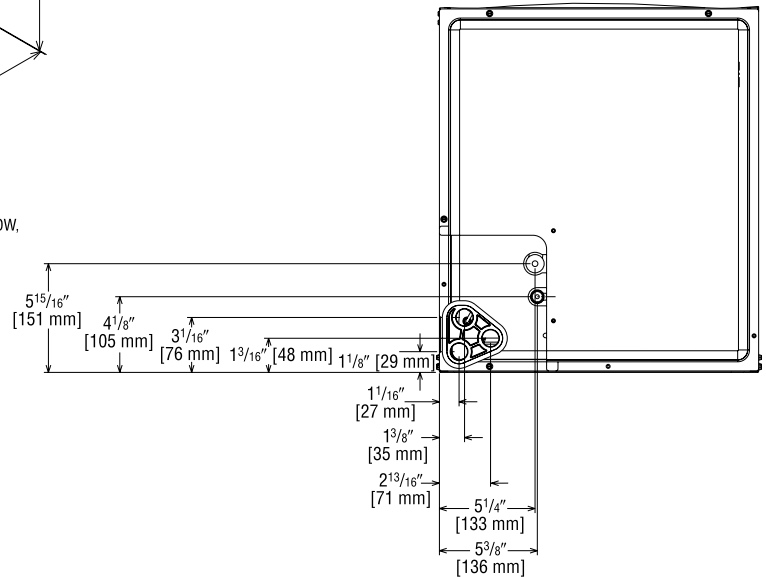
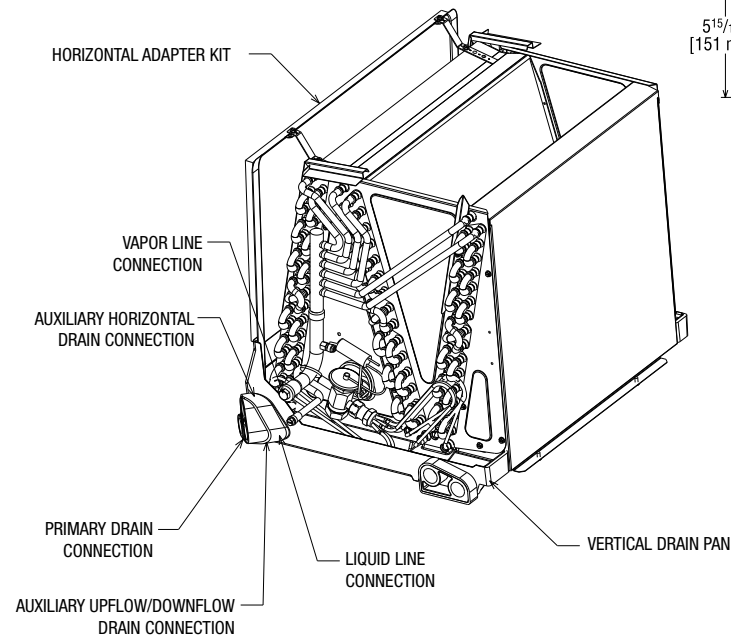

UPFLOW UNIT SHOWN:
UNIT MAY BE INSTALLED UPFLOW,
DOWNFLOW, HORIZONTAL RIGHT
OR LEFT AIR SUPPLY.

- [] Designates Metric Conversions
- () Designates Unit with Double Coil Cabinet

Unit Dimensions & Weights

Model Size RH1PY	Refrigerant Connections Sweat (In.) [mm] ID		Unit Width "W" In. [mm]	Unit Height "H" In. [mm]	Supply Duct "A" In. [mm]	Air Flow CFM (Nom.) [L/s]		Unit Weight/Shipping Weight (Lbs.) [kg]
	Liquid	Vapor				Lo	Hi	Unit With Coil (Max. KW)
1817S/2417S	3/8 [9.53]	3/4 [19.05]	17 1/2 [445]	42 1/2 [1080]	16 [406]	600 [283]	800 [378]	81/95 [37/43]
3017S/3617S	3/8 [9.53]	3/4 [19.05]	17 1/2 [445]	42 1/2 [1080]	16 [406]	1000 [472]	1200 [566]	90/104 [41/47]
3621S	3/8 [9.53]	7/8 [22.23]	21 [533]	42 1/2 [1080]	19 1/2 [495]	1200 [566]	—	109/124 [49/56]
4221S/4821S	3/8 [9.53]	7/8 [22.23]	21 [533]	50 1/2 [1282]	19 1/2 [495]	1400 [661]	1600 [755]	130/146 [59/66]
4824S	3/8 [9.53]	7/8 [22.23]	24 1/2 [622]	55 1/2 [1410]	23 [584]	1600 [755]	—	143/161 [65/73]
6024S	3/8 [9.53]	7/8 [22.23]	24 1/2 [622]	55 1/2 [1410]	23 [584]	—	1800 [850]	164/181 [75/82]

[] Designates Metric Conversions

Airflow Directional Data

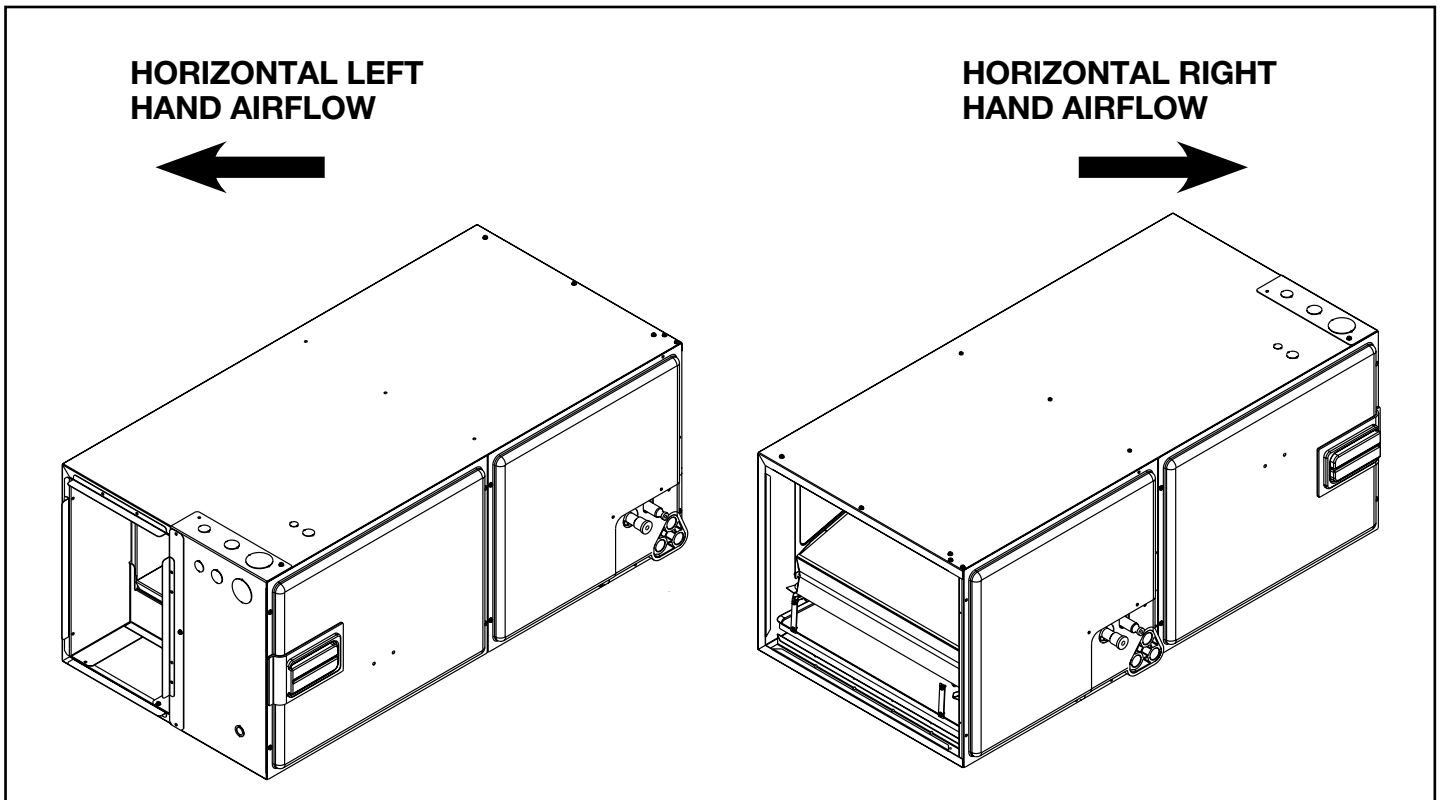
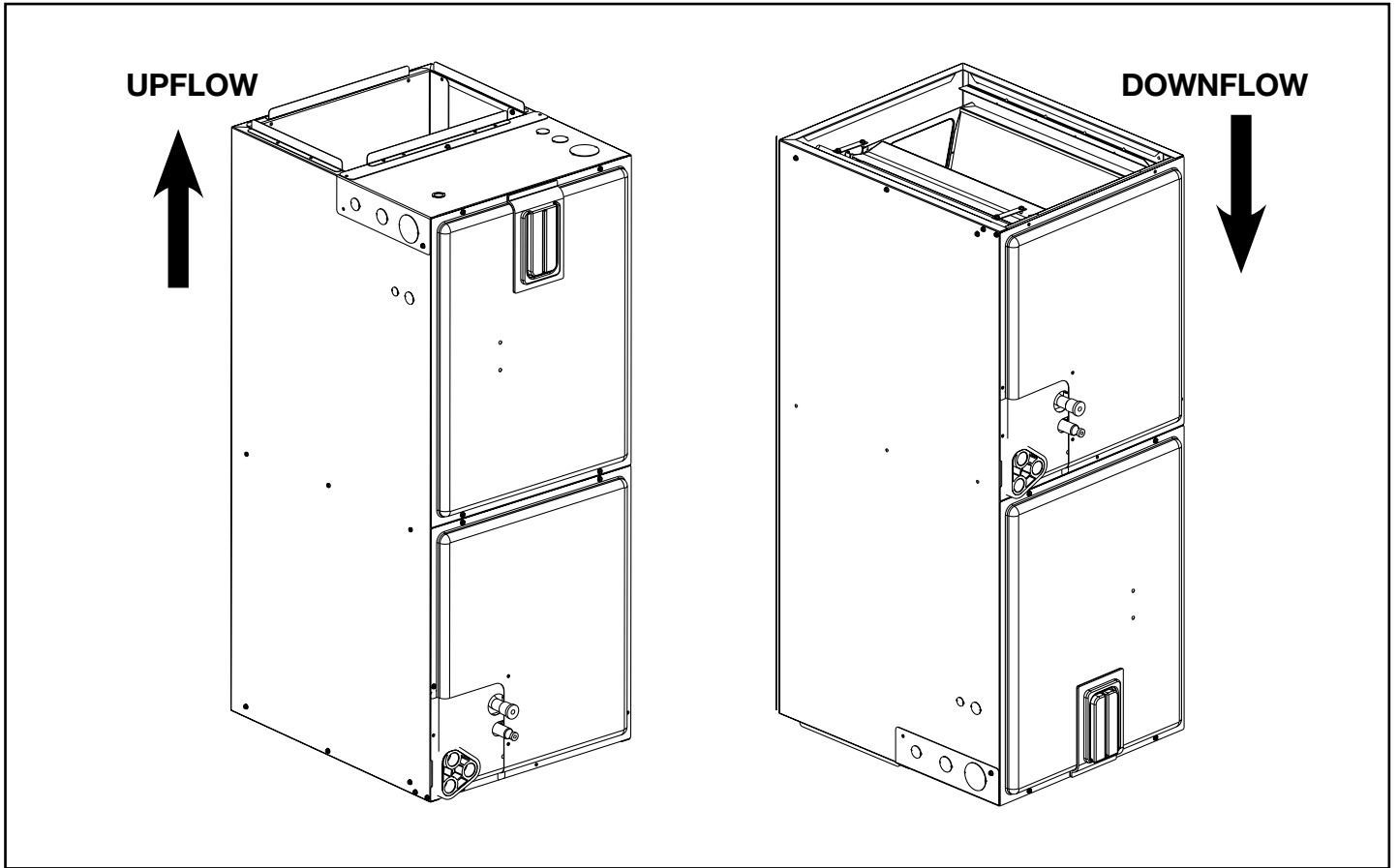

Airflow Performance

Airflow performance data is based on cooling performance with a coil and no filter in place. Select performance table for appropriate unit size, voltage and number of electric heaters to be used. Make sure external static applied to unit allows operation within the minimum and maximum limits shown in

table below for both cooling and electric heat operation. For optimum blower performance, operate the unit in the .3 [8 mm] to .7 inches [18 mm] W.C. external static range. Units with coils should be applied with a minimum of .1 inch [3 mm] W.C. external static range.

General Airflow Operating Limits

Cabinet Width	17		17/21		21			24	
Cooling BTUH x 1,000 Cooling Tons Nominal	18 1.5	24 2	30 2.5	36 3	42 3.5	48 4	60 5	48 4	60 5
Heat Pump or Air Conditioning Maximum Heat/Cool CFM [L/s] (37.5 CFM [18 L/s]/1,000 BTUH) (450 CFM [212 L/s]/Ton Nominal)	675 [319]	900 [425]	1125 [531]	1350 [637]	1575 [743]	1800 [850]	1925 [907]	1800 [850]	1930* [911]
Heat Pump or Air Conditioning Nominal Heat/Cool CFM [L/s] (33.3 CFM [16 L/s]/1,000 BTUH) (400 CFM [189 L/s]/Ton Nominal)	600 [283]	800 [378]	1000 [472]	1200 [566]	1400 [661]	1600 [755]	1750 [826]	1550 [732]	1800* [850]
Heat Pump or Air Conditioning Minimum Heat/Cool CFM [L/s] (30.0 CFM [14 L/s]/1,000 BTUH) (360 CFM [170 L/s]/Ton Nominal)	540 [255]	720 [340]	900 [425]	1080 [510]	1260 [595]	1440 [680]	1575 [743]	1440 [680]	1620* [765]
Maximum kW Electric Heating & Minimum Electric Heat CFM [L/s]	13 (6.13) 487 [230]	13 (6.13) 617 [291]	18 (8.49) 814 [384]	18 (8.49) 1054 [497]	20 (9.44) 1171 [553]	25 (11.8) 1502 [709]	25 (11.8) 1502 [709]	25 (11.8) 1502 [709]	30 (14.16) 1666 [786]
Maximum Electric Heat Rise °F [°C]	80 [26.7]	63 [17.2]	66 [18.9]	51 [10.6]	49 [9.4]	50 [10]	50 [10]	50 [10]	54 [12.2]

*CFM [L/s] per ton requirements are reduced for 5 ton systems.

[] Designates Metric Conversions

115/208 Airflow Performance Data: RH1PY (PSC Motor)

Air Handler Model RH1PY	Motor Speed From Factory	Manufacturer Recommended Air Flow Range (Min./Max.) CFM	Blower Size/ Motor HP [W] # of Speeds	Motor Speed	PSC CFM[L/s] Air Delivery/RPM/Watts (Dry Coil — No Filter)							
					External Static Pressure-Inches W.C.							
						0.1 [.02]	0.2 [.05]	0.3 [.07]	0.4 [.10]	0.5 [.12]	0.6 [.15]	0.7 [.17]
1817S No Heater	High	517/711 CFM [244/336 Us]	10x6 1/5HP [149] 2 Speed	Low	CFM	668 [315]	637 [301]	595 [281]	560 [264]	517 [244]	—	—
					RPM	541	596	657	706	761	—	—
					Watts	180	171	166	161	155	—	—
				High	CFM	—	—	—	—	711 [336]	662 [312]	614 [290]
					RPM	—	—	—	—	812	853	890
					Watts	—	—	—	—	243	227	210
1817S with 13kw Heater	High	487/661 CFM [230/312 Us]	10x6 1/5HP [149] 2 Speed	Low	CFM	638 [301]	607 [286]	565 [267]	530 [250]	487 [230]	—	—
					RPM	571	656	687	736	791	—	—
					Watts	171	162	157	152	146	—	—
				High	CFM	—	—	—	—	661 [312]	612 [289]	564 [266]
					RPM	—	—	—	—	837	878	915
					Watts	—	—	—	—	232	216	199
24175T No Heater	High	647/888 CFM [305/419 Us]	10x6 1/5HP [149] 2 Speed	Low	CFM	817 [386]	779 [368]	757 [357]	693 [327]	647 [305]	—	—
					RPM	616	667	715	770	808	—	—
					Watts	239	230	221	206	196	—	—
				High	CFM	—	—	—	—	888 [419]	828 [391]	774 [365]
					RPM	—	—	—	—	875	908	958
					Watts	—	—	—	—	331	313	301
2417S with 13kw Heater	High	617/838 CFM [291/395 Us]	10x6 1/5HP [149] 2 Speed	Low	CFM	787 [371]	749 [353]	727 [343]	663 [313]	617 [291]	—	—
					RPM	646	697	745	800	838	—	—
					Watts	230	221	212	197	187	—	—
				High	CFM	—	—	—	—	838 [395]	778 [367]	724 [342]
					RPM	—	—	—	—	900	933	983
					Watts	—	—	—	—	320	302	290
3017S No Heater	High	864/1004 CFM [408/474 Us]	10x8 1/4HP [186] 2 Speed	Low	CFM	1022 [482]	987 [466]	940 [444]	903 [426]	864 [408]	—	—
					RPM	700	754	794	833	870	—	—
					Watts	344	313	302	294	288	—	—
				High	CFM	—	—	—	—	1004 [474]	951 [449]	883 [417]
					RPM	—	—	—	—	924	953	975
					Watts	—	—	—	—	364	352	344
3017S with 18kw Heater	High	814/904 CFM [384/427 Us]	10x8 1/4HP [186] 2 Speed	Low	CFM	972 [459]	937 [442]	890 [420]	853 [403]	814 [384]	—	—
					RPM	750	804	844	883	920	—	—
					Watts	324	293	282	274	268	—	—
				High	CFM	—	—	—	—	904 [427]	851 [402]	783 [370]
					RPM	—	—	—	—	949	978	1000
					Watts	—	—	—	—	334	322	314
3617S/ 3621S No Heater	High	1110/1248 CFM [524/589 Us]	10x8 1/3HP [249] 2 Speed	Low	CFM	1201 [567]	1170 [552]	1141 [538]	1104 [521]	1062 [501]	—	—
					RPM	833	872	909	951	965	—	—
					Watts	462	427	406	396	385	—	—
				High	CFM	—	—	—	—	1194 [563]	1134 [535]	1078 [509]
					RPM	—	—	—	—	1024	1042	1060
					Watts	—	—	—	—	475	454	417

NOTE: "(—)" indicate airflow values outside unit static range. Some CFM values on the table are outside of the general airflow operating limits and are for reference only.

[] Designates Metric Conversions

115/208 Airflow Performance Data: RH1PY (PSC Motor) (Con't.)

Air Handler Model RH1PY	Motor Speed From Factory	Manufacturer Recommended Air Flow Range (Min./Max.) CFM	Blower Size/ Motor HP [W] # of Speeds	Motor Speed	PSC CFM[L/s] Air Delivery/RPM/Watts (Dry Coil — No Filter)							
					External Static Pressure-Inches W.C.							
						0.1 [.02]	0.2 [.05]	0.3 [.07]	0.4 [.10]	0.5 [.12]	0.6 [.15]	0.7 [.17]
3617S/ 3621S with 18kw Heater	High	1060/1148 CFM [500/542 Us]	10x8 1/3HP [249] 2 Speed	Low	CFM	1151 [543]	1120 [529]	1091 [515]	1054 [497]	1012 [478]	—	—
					RPM	883	922	959	1001	1015	—	—
					Watts	442	407	386	376	365	—	—
				High	CFM	—	—	—	—	1094 [516]	1034 [488]	978 [462]
					RPM	—	—	—	—	1049	1067	1085
					Watts	—	—	—	—	445	424	386
4221S No Heater	High	1241/1537 CFM [586/725 Us]	10x10 1/2HP [373] 2 Speed	Low	CFM	1493 [705]	1449 [684]	1363 [643]	1287 [607]	1211 [571]	—	—
					RPM	822	858	885	931	958	—	—
					Watts	540	519	506	484	459	—	—
				High	CFM	—	—	—	—	1514 [714]	1411 [666]	1315 [621]
					RPM	—	—	—	—	1061	1069	1078
					Watts	—	—	—	—	710	702	677
4221S with 20kw Heater	High	1225/1500 CFM [553/678 Us]	10x10 1/2HP [373] 2 Speed	Low	CFM	1423 [672]	1379 [651]	1293 [610]	1217 [574]	1141 [538]	—	—
					RPM	870	882	925	957	992	—	—
					Watts	514	508	490	461	431	—	—
				High	CFM	—	—	—	—	1414 [667]	1311 [619]	1215 [573]
					RPM	—	—	—	—	1067	1080	1094
					Watts	—	—	—	—	700	678	665
4821S/ 4824S No Heater	High	1395/1824 CFM [658/861 Us]	10x10 3/4HP [559] 2 Speed	Low	CFM	1488 [702]	1477 [670]	1466 [692]	1430 [675]	1395 [658]	—	—
					RPM	812	861	912	943	973	—	—
					Watts	554	545	526	508	491	—	—
				High	CFM	—	—	—	—	1824 [861]	1767 [834]	1653 [780]
					RPM	—	—	—	—	1102	1112	1121
					Watts	—	—	—	—	871	830	770
4821S/ 4824S with 25kw Heater	High	1225/1500 CFM [625/814 Us]	10x10 3/4HP [559] 2 Speed	Low	CFM	1418 [669]	1349 [637]	1396 [659]	1360 [642]	1325 [625]	—	—
					RPM	862	899	935	965	995	—	—
					Watts	534	525	506	588	471	—	—
				High	CFM	—	—	—	—	1724 [814]	1667 [787]	1553 [733]
					RPM	—	—	—	—	1116	1119	1130
					Watts	—	—	—	—	810	780	730
6024S No Heater	High	1710/1967 CFM [807/928 Us]	11x11 3/4HP [559] 2 Speed	Low	CFM	1866 [881]	1833 [865]	1806 [852]	1772 [836]	1710 [807]	—	—
					RPM	764	803	824	856	886	—	—
					Watts	514	756	733	715	701	—	—
				High	CFM	—	—	—	—	1967 [928]	1916 [904]	1863 [879]
					RPM	—	—	—	—	948	959	991
					Watts	—	—	—	—	850	827	816
6024S with 30kw Heater	High	1640/1796 CFM [773/847 Us]	11x11 3/4HP [559] 2 Speed	Low	CFM	1796 [848]	1763 [832]	1736 [819]	1702 [803]	1640 [774]	—	—
					RPM	828	860	878	890	1001	—	—
					Watts	735	718	705	695	678	—	—
				High	CFM	—	—	—	—	1867 [881]	1816 [857]	1763 [832]
					RPM	—	—	—	—	989	1005	1020
					Watts	—	—	—	—	818	795	780

NOTE: "(—)" indicate airflow values outside unit static range. Some CFM values on the table are outside of the general airflow operating limits and are for reference only.

[] Designates Metric Conversions

Electrical Data – Blower Motor Only – No Electric Heat

Air Handler Model RH1PY	Voltage	Phase*	Hertz	HP	RPM	Speeds	Circuit Amps.	Minimum Circuit Ampacity	Maximum Circuit Protector
1817S	115	1	60	1/5	1075	2	2.3	3.0	15
2417S				1/5	1075	2	3.8	5.0	15
3017S				1/4	1075	2	4.7	6.0	15
3617S/3621S				1/3	1075	2	6.1	8.0	15
4221S				1/2	1075	2	7.9	10.0	15
4821S				3/4	1075	2	8.4	11.0	15
1817S	208/240	1	60	1/5	1075	2	1.7	3.0	15
2417S				1/5	1075	2	1.7	3.0	15
3017S				1/4	1075	2	2.5	4.0	15
3617S/3621S				1/3	1075	2	2.5	4.0	15
4221S				1/2	1075	2	5.2	7.0	15
4821ST/4824ST				3/4	1075	2	5.2	7.0	15
6024ST				3/4	1075	2	5.2	7.0	15

Electrical Data – With Electric Heat

Air Handler Model RH1PY	Heater Model No.	Heater kW (208/240V)	PH/HZ	No. Elements kW Per	Type Supply Circuit Single Circuit Multiple Circuit	Heater Amps.	Motor Amps.	Minimum Circuit Ampacity	Maximum Overcurrent Protection
1817S 2417S (208/240V)	RXBH-17203J-1	2.25/3*0	1/60	1-3.0	SINGLE	10.8/125.	1.7	16/18	20/20
	RXBH-172403J-1	2.25/3.0	1/60	1-3.0	SINGLE	10.8/12.5	1.7	16/18	20/20
	RXBH-172405J-1	3.6/4.8	1/60	1-4.8	SINGLE	17.3/20.0	1.7	24/28	25/30
	RXBH-172407J-1	5.4/7.2	1/60	2-3.6	SINGLE	26.0/30.0	1.7	35/40	35/40
	RXBH-172410J-1	7.2/9.6	1/60	2-4.8	SINGLE	34.6/40.0	1.7	46/53	50/60
	RXBH-1724A13J-1	9.4/12.5	1/60	3-4.17	SINGLE	45.1/52.1	1.7	59/68	60/70
	RXBH-1724A13J-1	3.1/4.2	1/60	1-4.17	MULTIPLE CKT 1	15.0/17.4	1.7	21/24	25/25
		6.3/8.3	1/60	2-4.17	MULTIPLE CKT 2	30.1/34.7	0	38/44	40/45
	RXBH-1724A07C-1	5.4/7.2	3/60	3-2.4	SINGLE	15.0/17.3	1.7	21/24	25/25
	RXBH-1724A10C-1	7.2/9.6	3/60	3-3.2	SINGLE	20.0/23.1	1.7	28/31	30/35
RXBH-1724A13C-1	9.4/12.5	3/60	3-4.17	SINGLE	26.1/30.1	1.7	35/40	35/40	
3017S/ 3617S (208/240V)	RXBH-17203J-1	2.25/3.0	1/60	1-3.0	SINGLE	10.8/12.5	2.5	17/19	20/20
3017S 3617S 3621S (208/240V)	RXBH-172403J-1	2.25/3.0	1/60	1-3.0	SINGLE	10.8/12.5	2.5	17/19	20/20
	RXBH-172405J-1	3.6/4.8	1/60	1-4.8	SINGLE	17.3/20.0	2.5	25/29	25/30
	RXBH-172407J-1	5.4/7.2	1/60	2-3.6	SINGLE	26.0/30.0	2.5	36/41	40/45
	RXBH-172410J-1	7.2/9.6	1/60	2-4.8	SINGLE	34.6/40.0	2.5	47/54	50/60
	RXBH-1724A13J-1	9.4/12.5	1/60	3-4.17	SINGLE	45.1/52.1	2.5	60/69	60/70
	RXBH-1724A13J-1	3.1/4.2	1/60	1-4.17	MULTIPLE CKT 1	15.0/17.4	2.5	22/25	25/25
		6.3/8.3	1/60	2-4.17	MULTIPLE CKT 2	30.1/34.7	0	38/44	40/45
	RXBH-1724A15J-1	10.8/14.4	1/60	3-4.8	SINGLE	51.9/60.0	2.5	68/79	70/80
	RXBH-1724A15J-1	3.6/4.8	1/60	1-4.8	MULTIPLE CKT 1	17.3/20.0	2.5	25/29	25/30
		7.2/9.6	1/60	2-4.8	MULTIPLE CKT 2	34.6/40.0	0	44/50	45/50
	RXBH-1724A18J-1	12.8/17.0	1/60	3-5.68	SINGLE	61.6/70.8	2.5	81/92	90/100
	RXBH-1724A18J-1	4.3/5.7	1/60	1-5.68	MULTIPLE CKT 1	20.5/23.6	2.5	29/33	30/35
		8.5/11.3	1/60	2-5.68	MULTIPLE CKT 2	41.1/47.2	0	52/59	60/60
	RXBH-1724A07C-1	5.4/7.2	3/60	3-2.4	SINGLE	15.0/17.3	2.5	22/25	25/25
	RXBH-1724A10C-1	7.2/9.6	3/60	3-3.2	SINGLE	20.0/23.1	2.5	29/32	30/35
	RXBH-1724A13C-1	9.4/12.5	3/60	3-4.17	SINGLE	26.1/30.1	2.5	36/41	40/45
	RXBH-1724A15C-1	10.8/14.4	3/60	3-4.8	SINGLE	30.0/34.6	2.5	41/47	45/50
	RXBH-1724A18C-1	12.8/17.0	3/60	3-5.68	SINGLE	35.5/41.0	2.5	48/55	50/60

? Heater Kit Connection Type A = Breaker B = Terminal Block C = Pullout Disconnect

Electrical Data – With Electric Heat (Con't.)

Air Handler Model RH1PY	Heater Model No.	Heater kW (208/240V)	PH/HZ	No. Elements kW Per	Type Supply Circuit Single Circuit Multiple Circuit	Heater Amps.	Motor Amps.	Minimum Circuit Ampacity	Maximum Overcurrent Protection
4221S 4821S 4824S (208/240V)	RXBH-1724?05J-1	3.6/4.8	1/60	1-4.8	SINGLE	17.3/20.0	5.2	29/32	30/35
	RXBH-1724?07J-1	5.4/7.2	1/60	2-3.6	SINGLE	26.0/30.0	5.2	39/44	40/45
	RXBH-1724?10J-1	7.2/9.6	1/60	2-4.8	SINGLE	34.6/40.0	5.2	50/57	50/60
	RXBH-1724A15J-1	10.8/14.4	1/60	3-4.8	SINGLE	51.9/60.0	5.2	72/82	80/90
	RXBH-1724A15J-1	3.6/4.8	1/61	1-4.8	MULTIPLE CKT 1	17.3/20.0	5.2	29/32	30/35
		7.2/9.6	1/60	2-4.8	MULTIPLE CKT 2	34.6/40.0	0.0	44/50	45/50
	RXBH-1724A18J-1	12/8/17	1/60	3-5.68	SINGLE	61.6/70.8	5.2	84/95	90/100
	RXBH-1724A18J-1	4.3/5.7	1/60	1-5.68	MULTIPLE CKT 1	20.5/23.6	5.2	33/36	35/40
		8.5/11.3	1/60	1-5.68	MULTIPLECKT2	41.1/47.2	0.0	52/59	60/60
	RXBH-24A20J-1	14.4/19.2	1/60	4-4.8	SINGLE	69.2/80	5.2	93/107	100/110
	RXBH-24A20J-1	7.2/9.5	1/60	2-4.8	MULTIPLE CKT 1	34.6/40.0	5.2	50/57	50/60
		7.2/9.6	1/60	2-4.8	MULTIPLE CKT 2	34.6/40.0	0.0	44/50	45/50
	RXBH-24A25J-1	18.0/24.0	1/60	6-4.0	SINGLE	86.4/99.9	5.2	115/132	125/150
	RXBH-24A25J-1 (4-ton only)	6.0/8.0	1/60	2-4.0	MULTIPLE CKT 1	28.8/33.3	5.2	43/49	45/50
		6.0/8.0	1/60	2-4.0	MULTIPLE CKT 2	28.8/33.3	0.0	36/42	40/45
		6.0/8.0	1/60	2-4.0	MULTIPLE CKT 3	28.8/33.3	0.0	36/42	40/45
	RXBH-1724A070-1	5.4/7.2	3/60	3-2.4	SINGLE	15.0/17.3	5.2	26/29	30/30
	RXBH-1724A10C-1	7.2/9.6	3/60	3-3.2	SINGLE	20.0/23.1	5.2	32/36	35/40
	RXBH-1724A15C-1	10.8/14.4	3/60	3-4.8	SINGLE	30.0/34.6	5.2	44/50	45/50
	RXBH-1724A18C-1	12.8/17.0	3/60	3 - 5.68	SINGLE	35.6/41.0	5.2	51/58	60/60
	RXBH-24A20C-1	14.4/19.2	3/60	6-3.2	SINGLE	40.0/46.2	5.2	57/65	60/70
	RXBH-24A20C-1	7.2/9.6	3/60	3-3.2	MULTIPLE CKT 1	20.0/23.1	5.2	32/36	35/40
		7.2/9.6	3/60	3-3.2	MULTIPLE CKT 2	20.0/23.1	0.0	25/29	25/30
	RXBH-24A25C-1	18.0/24.0	3/60	6-4.0	SINGLE	50.0/57.8	5.2	69/79	70/80
	RXBH-24A25C-1 (4-ton only)	9.0/12.0	3/60	3-4.0	MULTIPLE CKT 1	25.0/28.9	5.2	38/43	40/45
		9.0/12.0	3/60	3-4.0	MULTIPLE CKT 2	25.0/28.9	0.0	32/37	35/40

? Heater Kit Connection Type A = Breaker B = Terminal Block C = Pullout Disconnect

Electrical Data – With Electric Heat (Con't.)

Air Handler Model RH1PY	Heater Model No.	Heater kW (208/240V)	PH/HZ	No. Elements kW Per	Type Supply Circuit Single Circuit Multiple Circuit	Heater Amps.	Motor Amps.	Minimum Circuit Ampacity	Maximum Overcurrent Protection
6024S (208/240V)	RXBH-1724?05J-1	3.6/4.8	1/60	1-4.8	SINGLE	17.3/20.0	5.2	29/32	30/35
	RXBH-1724?07J-1	5.4/7.2	1/60	2-3.6	SINGLE	26.0/30.0	5.2	39/44	40/45
	RXBH-1724?10J-1	7.2/9.6	1/60	2-4.8	SINGLE	34.6/40.0	5.2	50/57	50/60
	RXBH-1724A15J-1	10.8/14.4	1/60	3-4.8	SINGLE	51.9/60.0	5.2	72/82	80/90
	RXBH-1724A15J-1	3.6/4.8	1/60	1-4.8	MULTIPLE CKT1	17.3/20.0	5.2	29/32	30/35
		7.2/9.6	1/60	2-4.8	MULTIPLE CKT 2	34.6/40.0	0	44/50	45/50
	RXBH-1724A18J-1	12.8/17.0	1/60	3/5/68	SINGLE	61.6/70.8	5.2	84/95	90/100
	RXBH-1724A18J -1	4.3/5.7	1/60	1/5/68	MULTIPLE CKT 1	20.5/23.6	5.2	33/36	35/40
		8.5/11.3	1/60	2/5/68	MULTIPLECKT2	41.1/47.2	0	52/59	60/60
	RXBH-24A20J-1	14.4/19.2	1/60	4-4.8	SINGLE	69.2/80	5.2	93/107	100/110
	RXBH-24A20J-1	7.2/9.6	1/60	2-4.8	MULTIPLE CKT 1	34.6/40.0	5.2	50/57	50/60
		7.2/9.6	1/60	2-4.8	MULTIPLE CKT 2	34.6/40.0	0	44/50	45/50
	RXBH-24A25J-1	18.0/24.0	1/60	6-4.0	SINGLE	86.4/99.9	5.2	115/132	125/150
	RXBH-24A25J-1	6.0/8.0	1/60	2-4.0	MULTIPLE CKT 1	28.8/33.3	5.2	43/49	45/50
		6.0/8.0	1/60	2-4.0	MULTIPLE CKT 2	28.8/33.3	0	36/42	40/45
		6.0/8.0	1/60	2-4.0	MULTIPLE CKT 3	28.8/33.3	0	36/42	40/45
	RXBH-24A30J-1	21.6/28.8	1/60	6-4.8	SINGLE	103.8/120	5.2	137/157	150/175
	RXBH-24A30J-1	7.2/9.6	1/60	2-4.8	MULTIPLE CKT 1	34.6/40.0	5.2	50/57	50/60
		7.2/9.6	1/60	2-4.8	MULTIPLE CKT 2	34.6/40.0	0	44/50	45/50
		7.2/9.6	1/60	2-4.8	MULTIPLE CKT 3	34.6/40.0	0	44/50	45/50

? Heater Kit Connection Type A = Breaker B = Terminal Block C = Pullout Disconnect

Electrical Wiring

Power Wiring

- Field wiring must comply with the National Electrical Code (C.E.C. in Canada) and any applicable local ordinance.
- Supply wiring must be 75°C minimum copper conductors only.
- See electrical data for product Ampacity rating and Circuit Protector requirement.

Grounding

- This product must be sufficiently grounded in accordance with National Electrical Code (C.E.C. in Canada) and any applicable local ordinance.
- A grounding lug is provided.

Accessories

• Combustible Floor Base RXHB-

Model Cabinet Size	Combustible Floor Base Model Number
17	RXHB-17
21	RXHB-21
24	RXHB-24

- **Jumper Bar Kit 3 Ckt. to 1 Ckt. RXBJ-A31** is used to convert single phase multiple three circuit units to a single supply circuit. Kit includes cover and screw for line side terminals.
- **Jumper Bar Kit 2 Ckt. to 1 Ckt. RXBJ-A21** is used to convert single phase multiple two circuit units to a single supply circuit. Kit includes cover and screw for line side terminals.
- **Note:** No jumper bar kit is available to convert three phase multiple two circuit units to a single supply circuit.
- **Auxiliary Horizontal Overflow Pan Accessory RXBM-**

Nominal Cooling Capacity-Tons	Auxiliary Horizontal Overflow Pan Accessory Model Number
1 ¹ / ₂ - 3	RXBM-AC48
3 ¹ / ₂ - 5	RXBM-AC61

• Auxiliary Electric Heater Kits RXBH-

Heater Kits include circuit breakers which meet UL and cUL requirements for service disconnect. See the Electric Heat Electrical Data in this specification sheet for specific Heater Kit Model numbers.

• Horizontal Adapter Kit RXHH-

This horizontal adapter kit is used to convert Upflow/Downflow only models to horizontal flow. See the following table to order proper horizontal adapter kit.

Coil Model	Horizontal Adapter Kit Model Number (Single Qty.)	Horizontal Adapter Kit Model Number (10-Pack Qty.)
2414	RXHH-A01	RXHH-A01 x 10
2417	RXHH-A02	RXHH-A02 x 10
3617/3621	RXHH-A03	RXHH-A03 x 10
3821/4821/4824	RXHH-A04	RXHH-A04 x 10
3621HT/4821MT/6021ST	RXHH-06	RXHH-06 x 10
6024	RXHH-A05	RXHH-A05 x 10

• External Filter Base RXHF-

Model Cabinet Size	Filter Size In. [mm]	Part Number*	A	B
17	16 x 20 [406 x 508]	RXHF-17	15.70	17.5
21	20 x 20 [508 x 508]	RXHF-21	19.20	21.0
24	25 x 20 [635 x 508]	RXHF-24	22.70	25.5

*Accommodates 1" or 2" filter

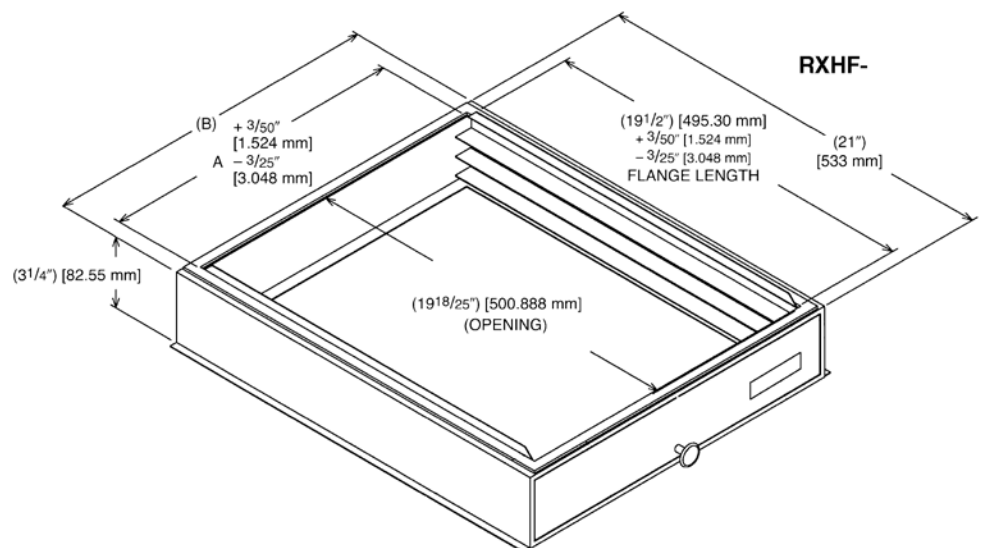
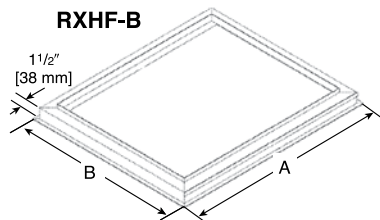

[] Designates Metric Conversions



GENERAL TERMS OF LIMITED WARRANTY*

Ruud will furnish a replacement for any part of this product which fails in normal use and service within the applicable periods stated, in accordance with the terms of the limited warranty.

Conditional Parts
(Registration Required)..... Ten (10) Years

***For complete details of the Limited and Conditional Warranties, including applicable terms and conditions, contact your local contractor or the Manufacturer for a copy of the product warranty certificate.**

Before proceeding with installation, refer to installation instructions packaged with each model, as well as complying with all Federal, State, Provincial, and Local codes, regulations, and practices.

© 2024 Rheem Manufacturing Company. Ruud trademarks owned by Rheem Manufacturing Company.

In keeping with its policy of continuous progress and product improvement, Ruud reserves the right to make changes without notice.

5600 Old Greenwood Road
Fort Smith, Arkansas 72908 • www.ruud.com

125 Edgeware Road, Unit 1
Brampton, Ontario • L6Y 0P5 • ruud-canada.ca