



Commercial Water



# TANKLESS WATER HEATER INSTALLATION DIAGRAMS





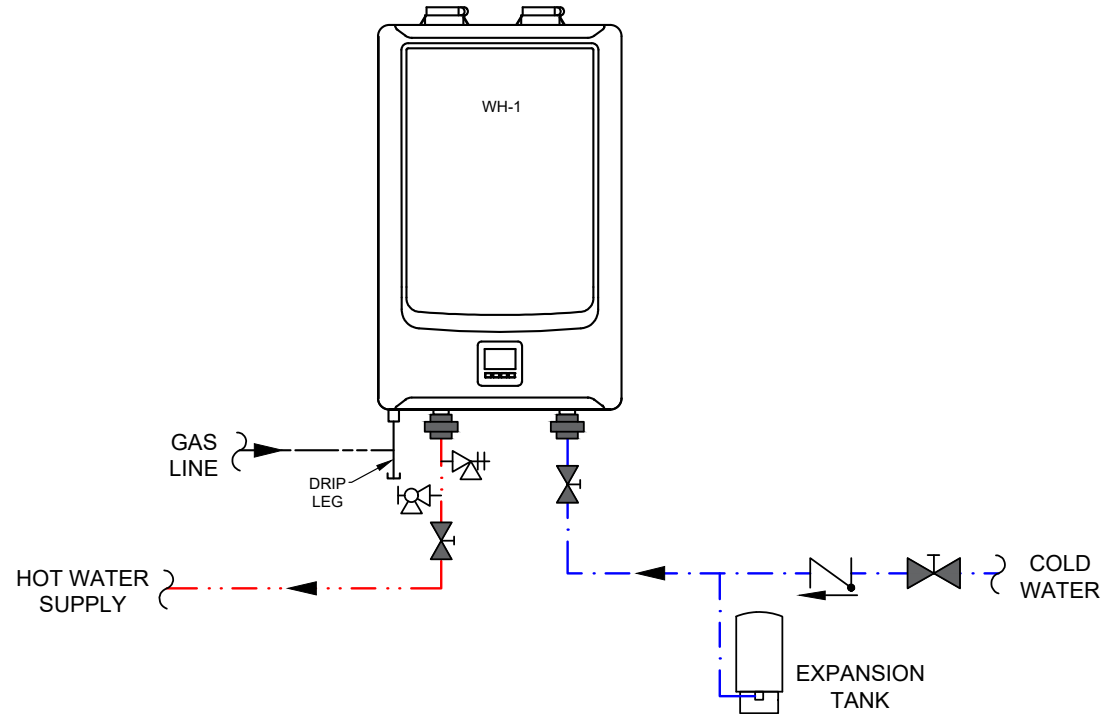



## PIPING DIAGRAM: ONE UNIT TANKLESS, NO RE-CIRCULATION

This drawing is for reference only and shall not be used as an alternative to a professional engineered project drawing. Any use of this drawing is the responsibility of the party using it. Refer to local codes or building officials prior to installation.



### NOTES:

- Unions are recommended on all water connections.
- This drawing is for illustration purpose only. Please refer to local code requirements for installation of plumbing components and pipe sizes.
- Multiple heaters should be piped in parallel or in first-in / last-out (reverse/return) configuration.
- Optional service valve kits are available and can be provided by Rheem.
- All gas heaters should be vented per Rheem guidelines. Venting is not shown in this schematic. It should be done in accordance with Use and care manual.
- Gas piping detail not shown in this drawing. Please refer to the Use & Care Manual and/or local codes for proper gas piping.
- Condensation drain is not shown. Please refer to Use & Care Manual and local codes for proper removal of condensation.

LEGEND	
	SHUT-OFF VALVE
	UNION
	DRAIN
	CHECK VALVE
	PRESSURE RELIEF VALVE
	COLD WATER
	HOT WATER
	RE-CIRCULATION
	GAS LINE

## PIPING DIAGRAM: ONE UNIT TANKLESS, BUILT-IN RE-CIRCULATION

This drawing is for reference only and shall not be used as an alternative to a professional engineered project drawing. Any use of this drawing is the responsibility of the party using it. Refer to local codes or building officials prior to installation.

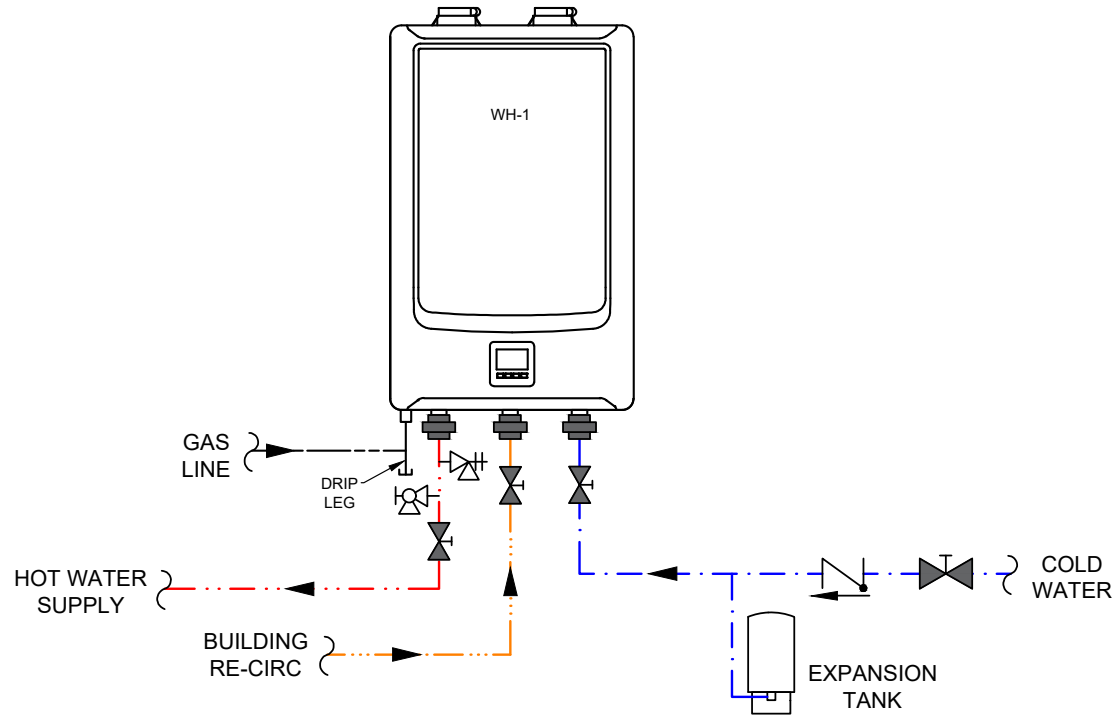

### NOTES:

- Unions are recommended on all water connections.
- This drawing is for illustration purpose only. Please refer to local code requirements for installation of plumbing components and pipe sizes.
- Multiple heaters should be piped in parallel or in first in last out (reverse return) configuration.
- Tankless water heater includes a built-in recirc pump. See Use & Care Manual for recirc pump settings.
- Optional service valve kits are available and can be provided by Rheem.
- All gas heaters should be vented per Rheem guidelines. Venting is not shown in this schematic. It should be done in accordance with Use and care manual.
- Gas piping detail not shown in this drawing. Please refer to the Use & Care Manual and/or local codes for proper gas piping.
- Condensation drain is not shown. Please refer to Use & Care Manual and local codes for proper removal of condensation.

LEGEND	
	SHUT-OFF VALVE
	UNION
	DRAIN
	CHECK VALVE
	PRESSURE RELIEF VALVE
	COLD WATER
	HOT WATER
	RE-CIRCULATION
	GAS LINE





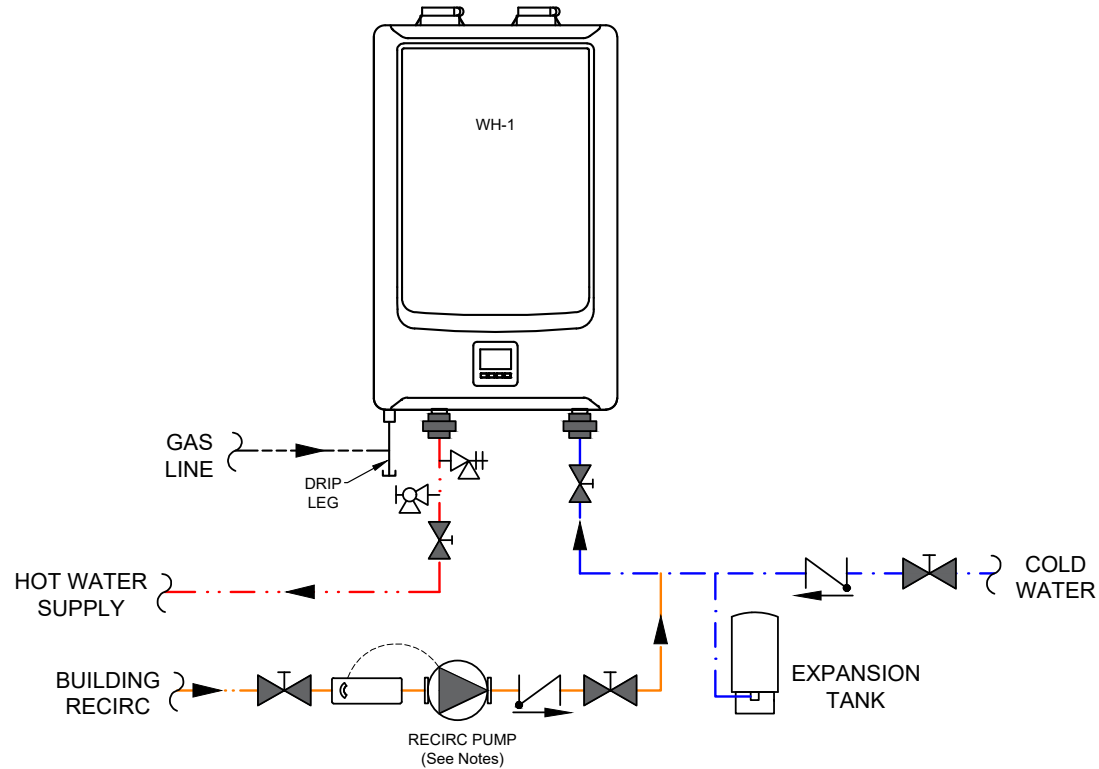



## PIPING DIAGRAM: ONE UNIT TANKLESS, EXTERNAL RE-CIRCULATION

This drawing is for reference only and shall not be used as an alternative to a professional engineered project drawing. Any use of this drawing is the responsibility of the party using it. Refer to local codes or building officials prior to installation.



### NOTES:

- Unions are recommended on all water connections.
- Multiple heaters should be piped in parallel or first-in/last-out (reverse/return) configuration.
- Optional service valve kits are available and can be provided by Rheem.
- Recirc pump should be sized to meet a flow rate of 2.5 gpm per tankless at 25 ft. of head plus the total pressure drop from building loop.
- Recirc pump should be controlled by an aquastat and/or a timer.
- All gas heaters should be vented per Rheem guidelines. Venting is not shown in this schematic. It should be done in accordance with Use and care manual.
- Gas piping detail not shown in this drawing. Please refer to the Use & Care Manual and/or local codes for proper gas piping.
- Condensation drain is not shown. Please refer to Use & Care Manual and local codes for proper removal of condensation.

LEGEND	
	SHUT-OFF VALVE
	DRAIN
	CHECK VALVE
	PRESSURE RELIEF VALVE
	AQUA-STAT
	COLD WATER
	HOT WATER
	RE-CIRCULATION
	GAS LINE





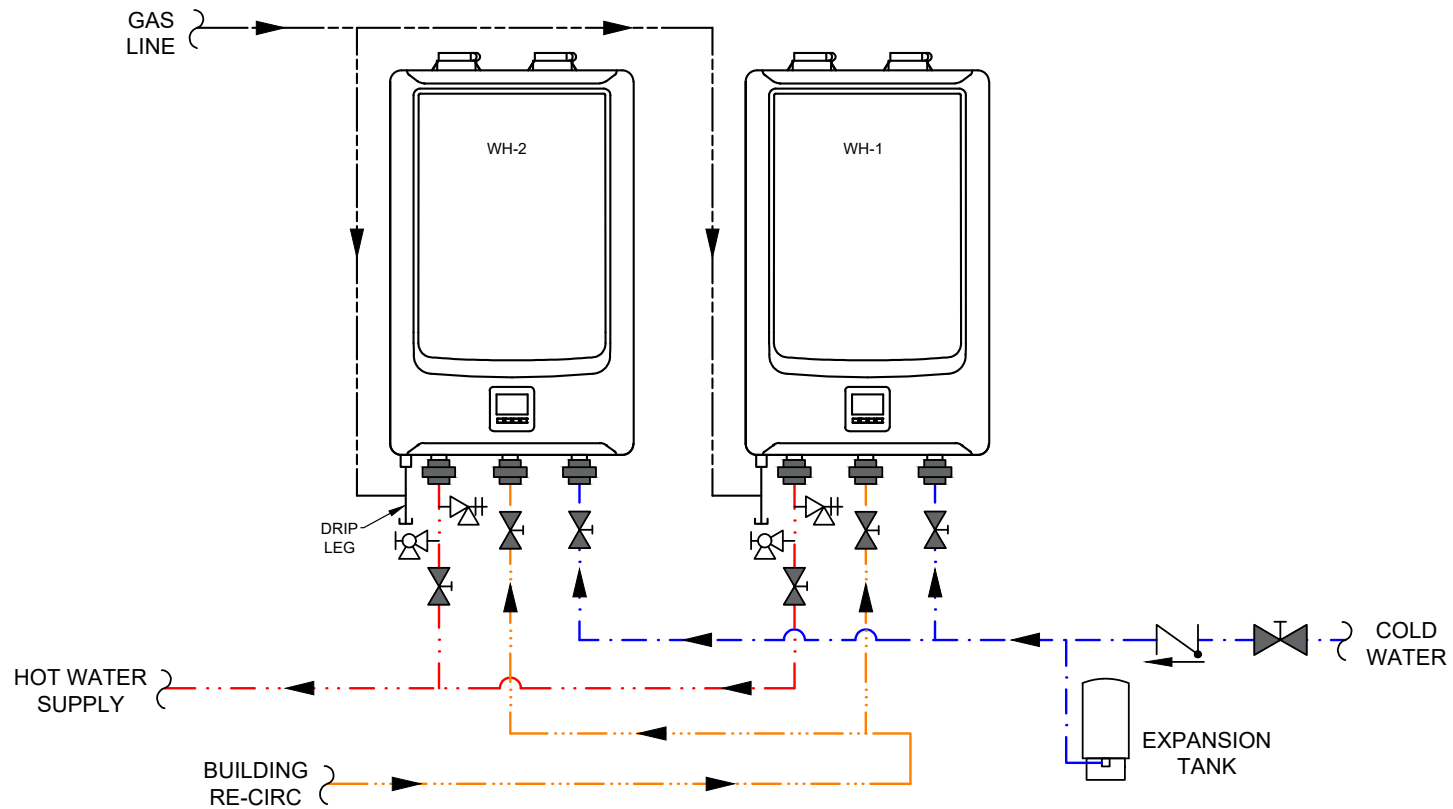



## PIPING DIAGRAM: TWO UNITS TANKLESS, BUILT-IN RE-CIRCULATION

This drawing is for reference only and shall not be used as an alternative to a professional engineered project drawing. Any use of this drawing is the responsibility of the party using it. Refer to local codes or building officials prior to installation.



**NOTES:**

- Unions are recommended on all water connections.
- This drawing is for illustration purpose only. Please refer to local code requirements for installation of plumbing components and pipe sizes.
- Multiple heaters should be piped in parallel or first-in/last-out (reverse/return) configuration.
- Tankless water heater includes a built-in recirc pump. See Use & Care Manual for recirc pump settings.
- Optional service valve kits are available and can be provided by Rheem.
- All gas heaters should be vented per Rheem guidelines. Venting is not shown in this schematic. It should be done in accordance with Use and care manual.
- Gas piping detail not shown in this drawing. Please refer to the Use & Care Manual and/or local codes for proper gas piping.
- Condensation drain is not shown. Please refer to Use & Care Manual and local codes for proper removal of condensation.

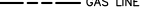
LEGEND	
	SHUT-OFF VALVE
	UNION
	DRAIN
	CHECK VALVE
	PRESSURE RELIEF VALVE
	COLD WATER
	HOT WATER
	RE-CIRCULATION
	GAS LINE

## PIPING DIAGRAM: TWO UNIT TANKLESS, ONE STORAGE TANK, EXTERNAL RE-CIRCULATION

This drawing is for reference only and shall not be used as an alternative to a professional engineered project drawing. Any use of this drawing is the responsibility of the party using it. Refer to local codes or building officials prior to installation.

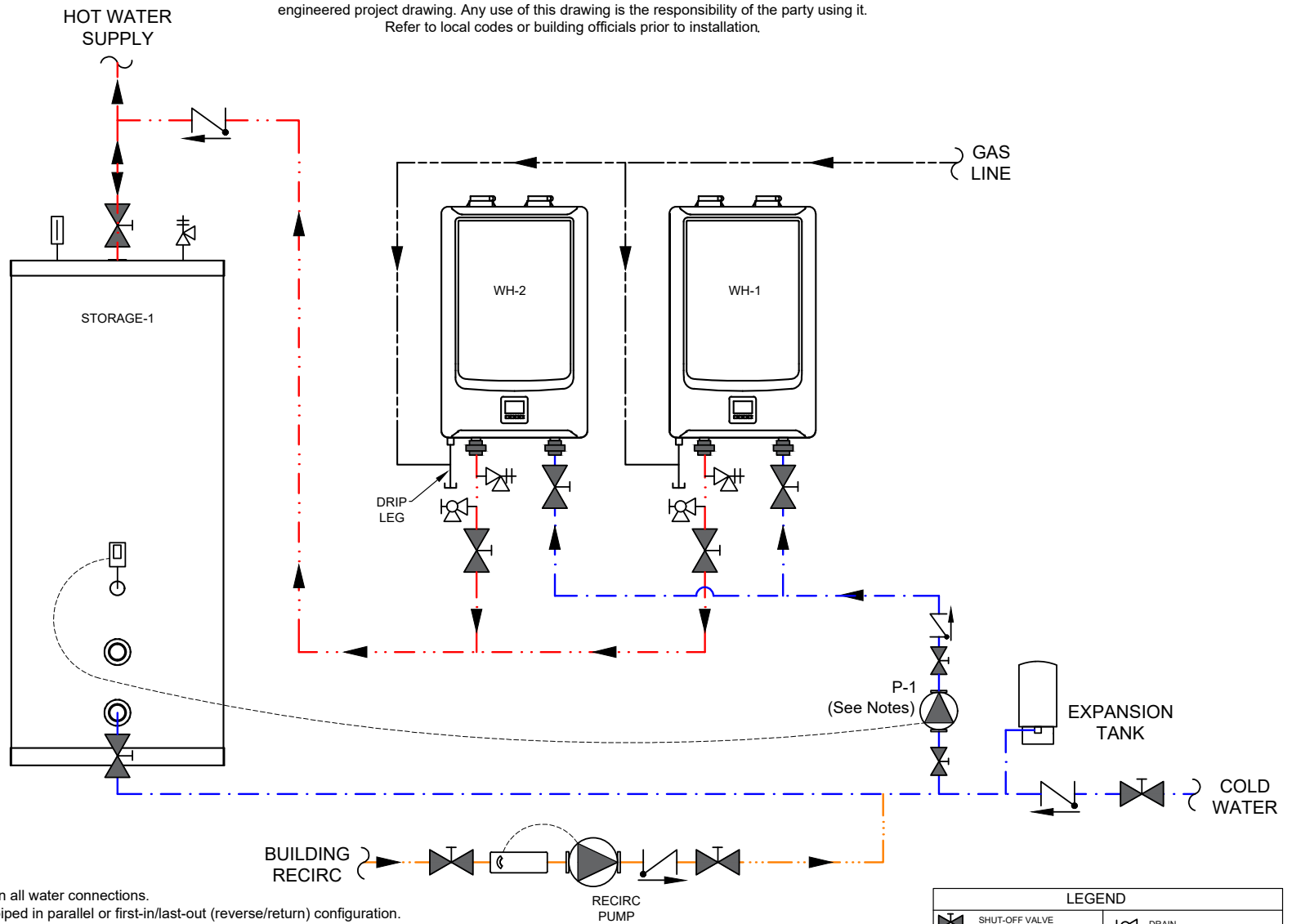

**NOTES:**

- Unions are recommended on all water connections.
- Multiple heaters should be piped in parallel or first-in/last-out (reverse/return) configuration.
- P-1 pump controlled by tank-stat. P-1 pump selection based on total flow rate of tankless units at design delta T. Refer to specs for tankless unit(s) pressure drop at design flow rate.
- Building recirc pump should be controlled by an aqua-stat and/or a timer. Recirc pump sized to meet flow and pressure drop of building loop.
- All gas heaters should be vented per Rheem guidelines. Venting is not shown in this schematic. It should be done in accordance with Use and care manual.
- Gas piping detail not shown in this drawing. Please refer to the Use & Care Manual and/or local codes for proper gas piping.
- Condensation drain is not shown. Refer to Use & Care Manual and local codes for proper removal of condensation.

LEGEND	
	SHUT-OFF VALVE
	TEMPERATURE GAUGE
	CHECK VALVE
	RELIEF VALVE
	AQUA-STAT
	TANK-STAT
	DRAIN
	COLD WATER
	HOT WATER
	RE-CIRCULATION
	GAS LINE
	SIGNAL WIRING





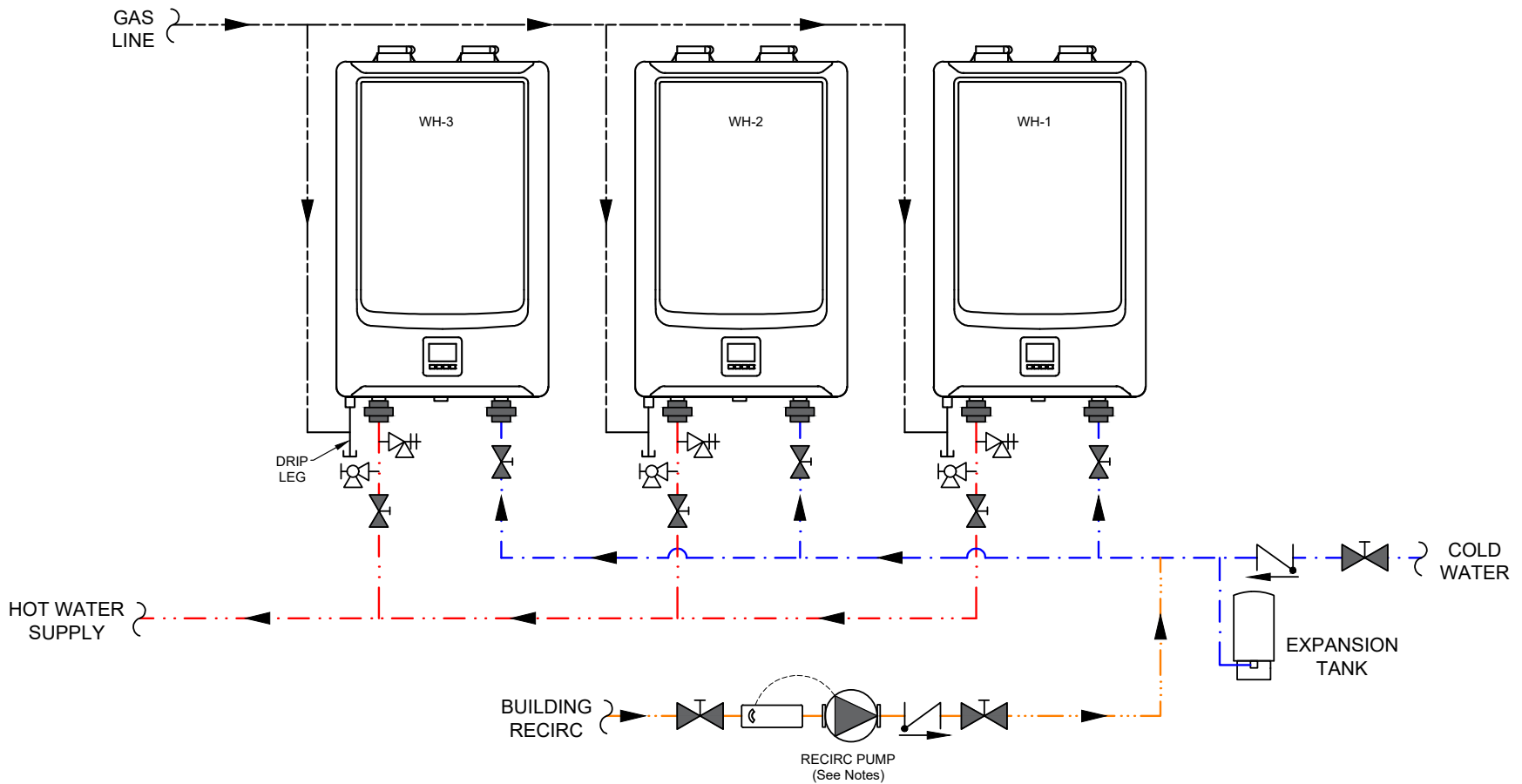



## PIPING DIAGRAM: THREE UNIT TANKLESS, EXTERNAL RE-CIRCULATION

This drawing is for reference only and shall not be used as an alternative to a professional engineered project drawing. Any use of this drawing is the responsibility of the party using it. Refer to local codes or building officials prior to installation.

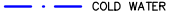

**NOTES:**

- Unions are recommended on all water connections.
- Multiple heaters should be piped in parallel or in first in last out (reverse return) configuration.
- Optional service valve kits are available and can be provided by Rheem.
- Recirc pump should be sized to meet a flow rate of 2.5 gpm per tankless at 25 ft. of head plus the total pressure drop from the building loop.
- Recirc pump should be controlled by an aquastat and/or a timer.
- All gas heaters should be vented per Rheem guidelines. Venting is not shown in this schematic. It should be done in accordance with Use and care manual.
- Gas piping detail not shown in this drawing. Please refer to the Use & Care Manual and/or local codes for proper gas piping.
- Condensation drain is not shown. Please refer to Use & Care Manual and local codes for proper removal of condensation.

LEGEND	
	SHUT-OFF VALVE
	DRAIN
	CHECK VALVE
	PRESSURE RELIEF VALVE
	AQUA-STAT
	COLD WATER
	HOT WATER
	RE-CIRCULATION
	GAS LINE

## PIPING DIAGRAM: THREE UNIT TANKLESS, TWO STORAGE TANKS, EXTERNAL RE-CIRCULATION

This drawing is for reference only and shall not be used as an alternative to a professional engineered project drawing. Any use of this drawing is the responsibility of the party using it. Refer to local codes or building officials prior to installation.

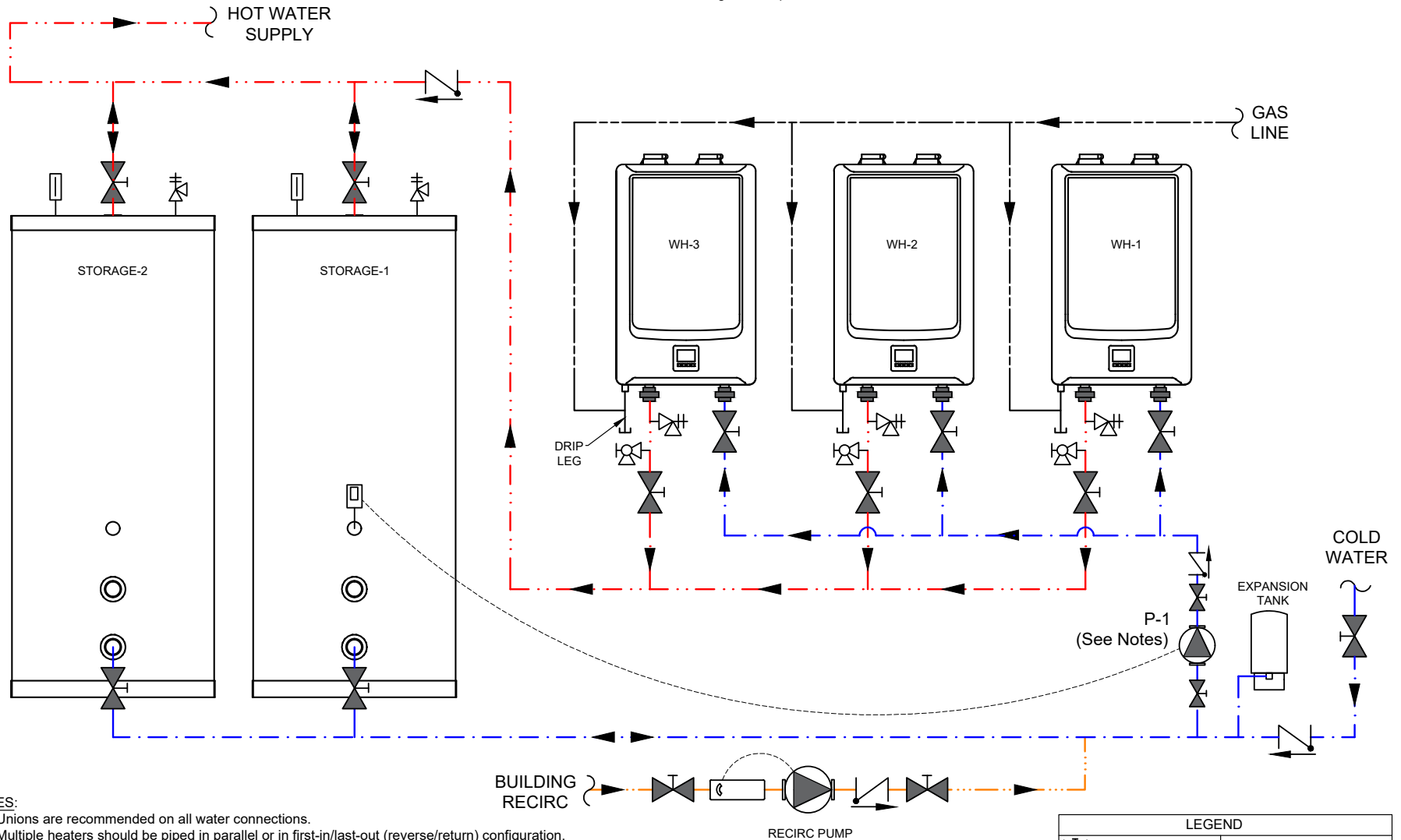

### NOTES:

- Unions are recommended on all water connections.
- Multiple heaters should be piped in parallel or in first-in/last-out (reverse/return) configuration.
- P-1 pump controlled by tank-stat. P-1 pump selection based on total flow rate of tankless units at design delta T. Refer to specs for tankless unit(s) pressure drop at design flow rate.
- Building recirc pump should be controlled by an aqua-stat and/or a timer. Recirc pump sized to meet flow and pressure drop of building loop.
- For indoor installs, all gas heaters should be vented per Rheem guidelines. Venting is not shown in this schematic. It should be done in accordance with Use and care manual.
- Gas piping detail not shown in this drawing. Please refer to the Use & Care Manual and/or local codes for proper gas piping.
- Condensation drain is not shown. Refer to Use & Care Manual and local codes for proper removal of condensation.

LEGEND	
	SHUT-OFF VALVE
	TEMPERATURE GAUGE
	CHECK VALVE
	RELIEF VALVE
	AQUA-STAT
	TANK-STAT
	DRAIN
	COLD WATER
	HOT WATER
	RE-CIRCULATION
	GAS LINE
	SIGNAL WIRING



## PIPING DIAGRAM: TWELVE UNIT TANKLESS, EXTERNAL RE-CIRCULATION

This drawing is for reference only and shall not be used as an alternative to a professional engineered project drawing. Any use of this drawing is the responsibility of the party using it. Refer to local codes or building officials prior to installation.

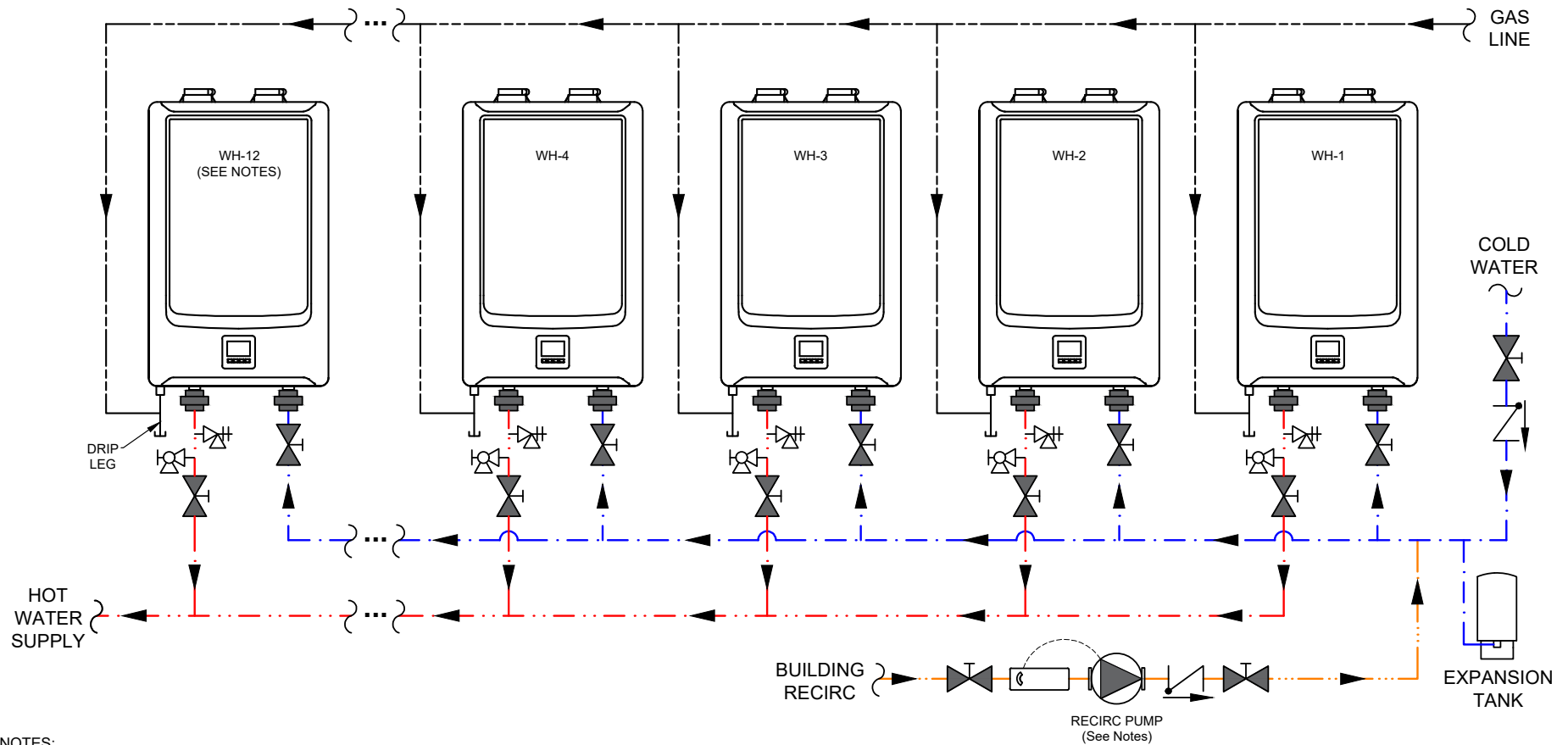

**NOTES:**

- Up to 12 tankless units can be common vented. For installs with more than 12 units, a separate common vent kit must be used.
- Unions are recommended on all water connections.
- Multiple heaters should be piped in parallel or first-in/last-out (reverse/return) configuration.
- Optional service valve kits are available and can be provided by Rheem.
- Recirc pump should be sized to meet a flow rate of 2.5 gpm per tankless at 25 ft. of head plus the total pressure drop from the building loop.
- Recirc pump should be controlled by an aquastat and/or a timer.
- All gas heaters should be vented per Rheem guidelines. Venting is not shown in this schematic. It should be done in accordance with Use and care manual.
- Gas piping detail not shown in this drawing. Please refer to the Use & Care Manual and/or local codes for proper gas piping.
- Condensation drain is not shown. Please refer to Use & Care Manual and local codes for proper removal of condensation.

LEGEND	
	SHUT-OFF VALVE
	DRAIN
	CHECK VALVE
	PRESSURE RELIEF VALVE
	AQUA-STAT
	COLD WATER
	HOT WATER
	RE-CIRCULATION
	GAS LINE





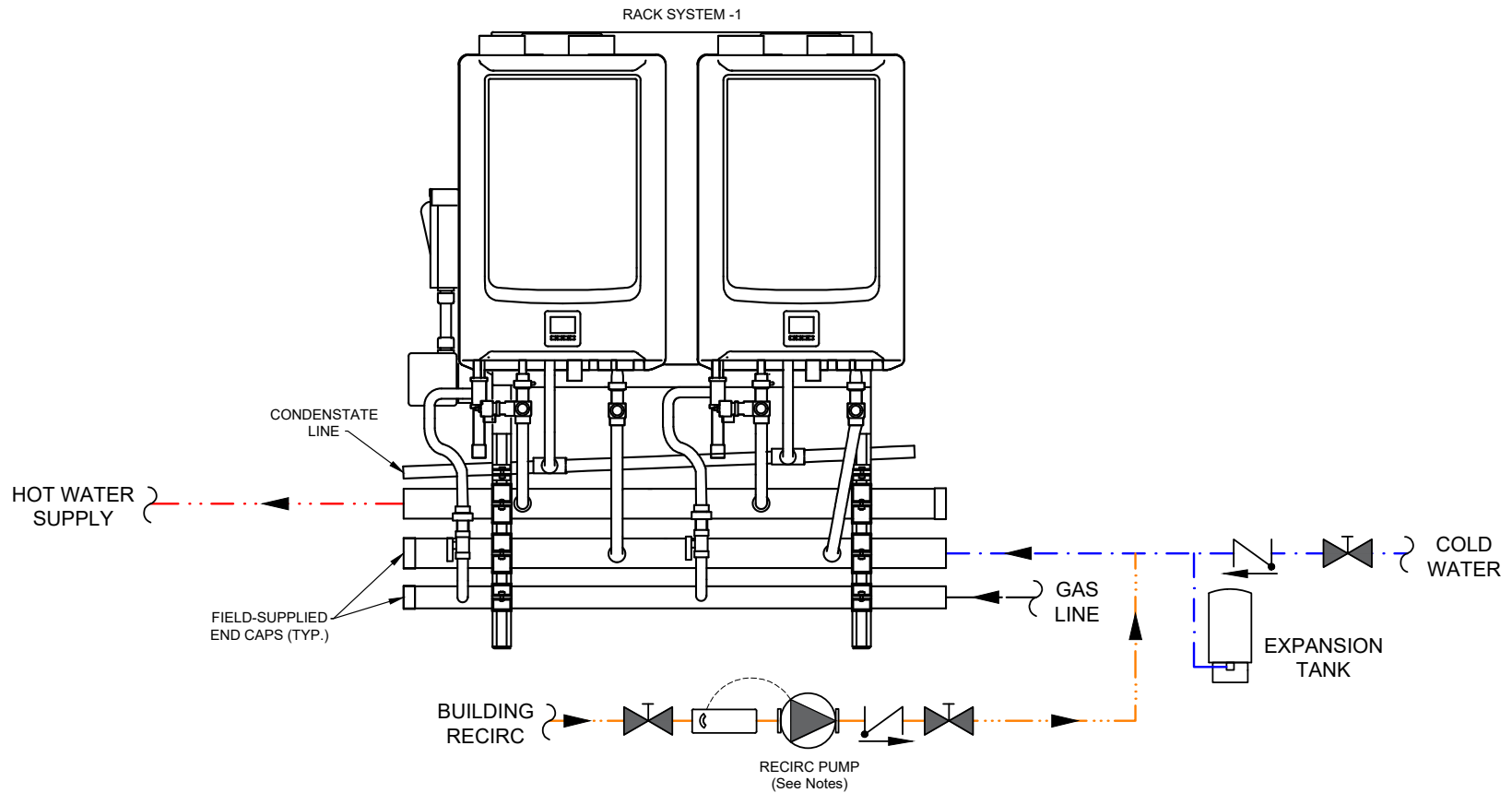



## PIPING DIAGRAM: TWO TO FOUR UNIT TANKLESS RACK SYSTEM, EXTERNAL RE-CIRCULATION

This drawing is for reference only and shall not be used as an alternative to a professional engineered project drawing. Any use of this drawing is the responsibility of the party using it. Refer to local codes or building officials prior to installation.



### NOTES:

- Unions are recommended on all water connections.
- Multiple rack systems should be piped in parallel or first-in/last-out (reverse/return) configuration.
- See rack system manual for manifold pipe sizes.
- Recirc pump should be sized to meet a flow rate of 2.5 gpm per tankless at 25 ft. of head plus the total pressure drop from building loop.
- Recirc pump should be controlled by an aquastat and/or a timer.
- All gas heaters should be vented per Rheem guidelines. Venting is not shown in this schematic. It should be done in accordance with Use and care manual.
- Gas piping detail not shown in this drawing. Please refer to the Use & Care Manual and/or local codes for proper gas piping.
- Condensation drain is not shown. Please refer to Use & Care Manual and local codes for proper removal of condensation.

LEGEND	
	SHUT-OFF VALVE
	DRAIN
	CHECK VALVE
	PRESSURE RELIEF VALVE
	AQUA-STAT
	COLD WATER
	HOT WATER
	RE-CIRCULATION
	GAS LINE





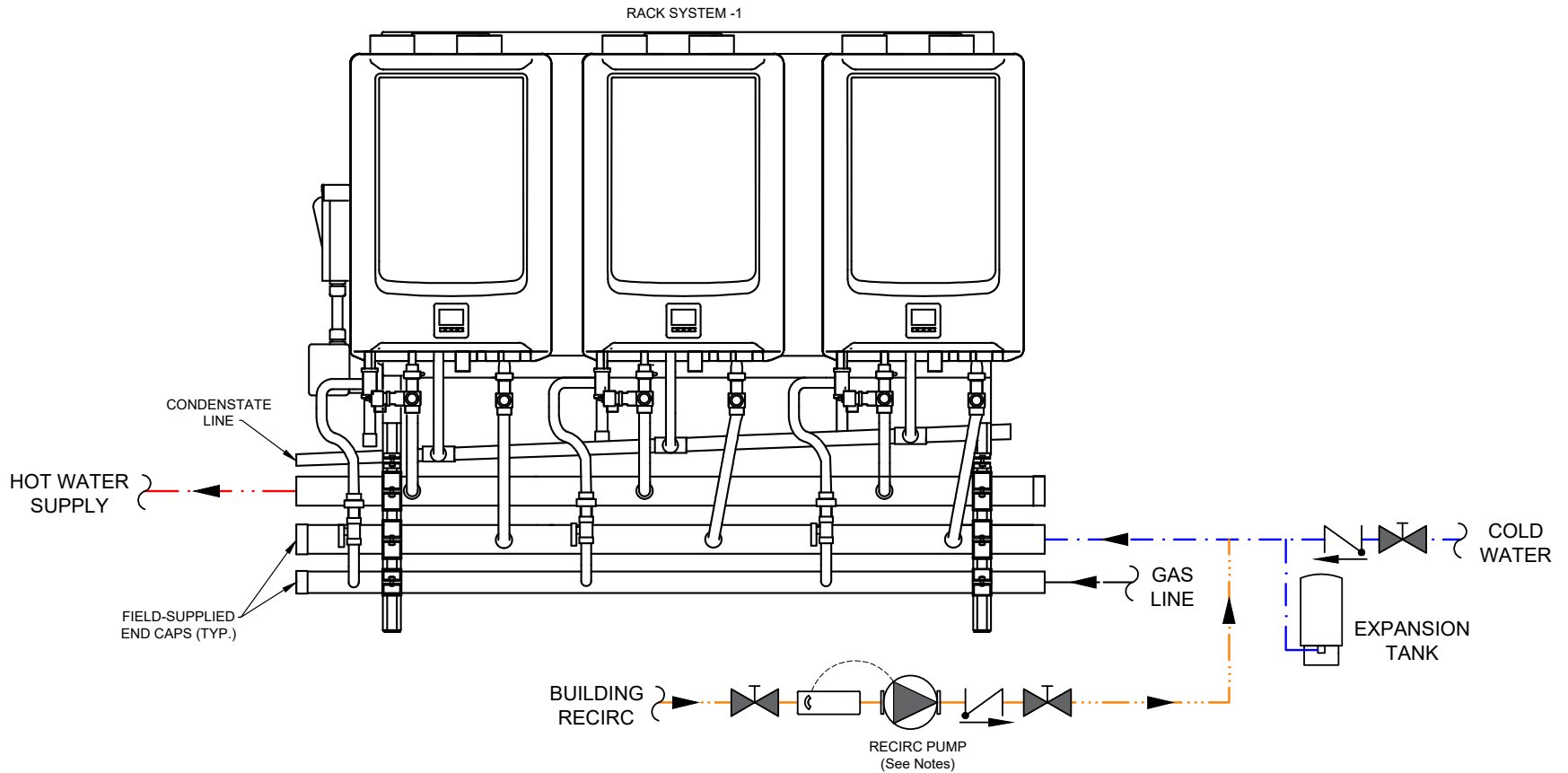



## PIPING DIAGRAM: THREE TO SIX UNIT TANKLESS RACK SYSTEM, EXTERNAL RE-CIRCULATION

This drawing is for reference only and shall not be used as an alternative to a professional engineered project drawing. Any use of this drawing is the responsibility of the party using it. Refer to local codes or building officials prior to installation.



### NOTES:

- Unions are recommended on all water connections.
- Multiple rack systems should be piped in parallel or first-in/last-out (reverse/return) configuration.
- See rack system manual for manifold pipe sizes.
- Recirc pump should be sized to meet a flow rate of 2.5 gpm per tankless at 25 ft. of head plus the total pressure drop from building loop.
- Recirc pump should be controlled by an aquastat and/or a timer.
- All gas heaters should be vented per Rheem guidelines. Venting is not shown in this schematic. It should be done in accordance with Use and care manual.
- Gas piping detail not shown in this drawing. Please refer to the Use & Care Manual and/or local codes for proper gas piping.
- Condensation drain is not shown. Please refer to Use & Care Manual and local codes for proper removal of condensation.

LEGEND	
	SHUT-OFF VALVE
	DRAIN
	CHECK VALVE
	PRESSURE RELIEF VALVE
	AQUA-STAT
	COLD WATER
	HOT WATER
	RE-CIRCULATION
	GAS LINE

## PIPING DIAGRAM: ONE TANKLESS RACK SYSTEM, ONE STORAGE TANK, EXTERNAL RE-CIRCULATION

This drawing is for reference only and shall not be used as an alternative to a professional engineered project drawing. Any use of this drawing is the responsibility of the party using it. Refer to local codes or building officials prior to installation.

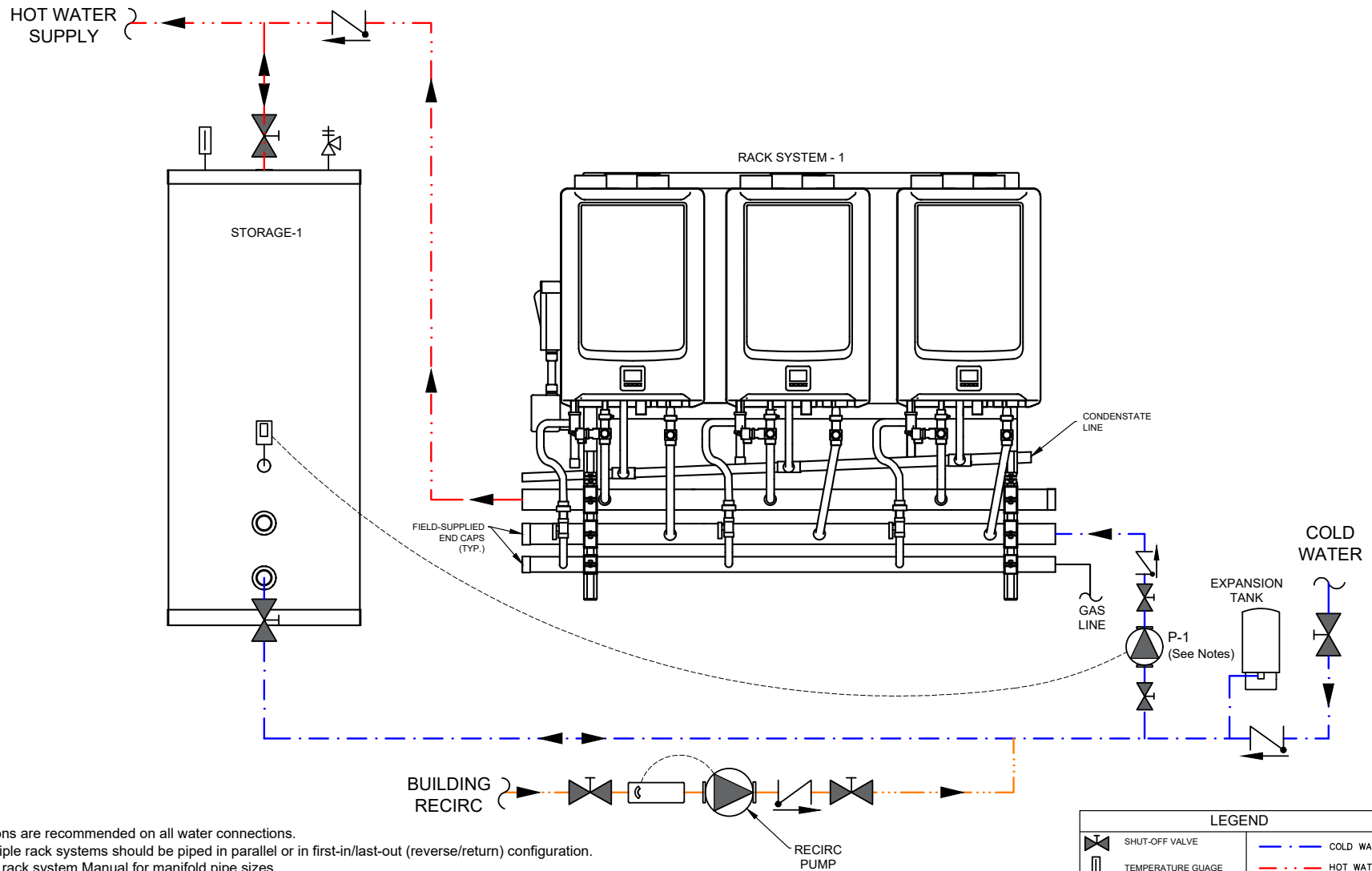

### NOTES:

- Unions are recommended on all water connections.
- Multiple rack systems should be piped in parallel or in first-in/last-out (reverse/return) configuration.
- See rack system Manual for manifold pipe sizes.
- P-1 pump controlled by tank-stat. P-1 pump selection based on total flow rate of tankless units at design delta T. Refer to specs for tankless unit(s) pressure drop at design flow rate.
- Building recirc pump should be controlled by an aqua-stat and/or a timer. Recirc pump sized to meet flow and pressure drop of building loop.
- All gas heaters should be vented per Rheem guidelines. Venting is not shown in this schematic. It should be done in accordance with Use and care manual.
- Gas piping detail not shown in this drawing. Please refer to the Use & Care Manual and/or local codes for proper gas piping.
- Condensation drain is not shown. Please refer to Use & Care Manual and local codes for proper removal of condensation.

### LEGEND

	SHUT-OFF VALVE		COLD WATER
	TEMPERATURE GAUGE		HOT WATER
	CHECK VALVE		RE-CIRCULATION
	T & P RELIEF VALVE		GAS LINE
	AQUA-STAT		SIGNAL WIRING
	TANK-STAT		





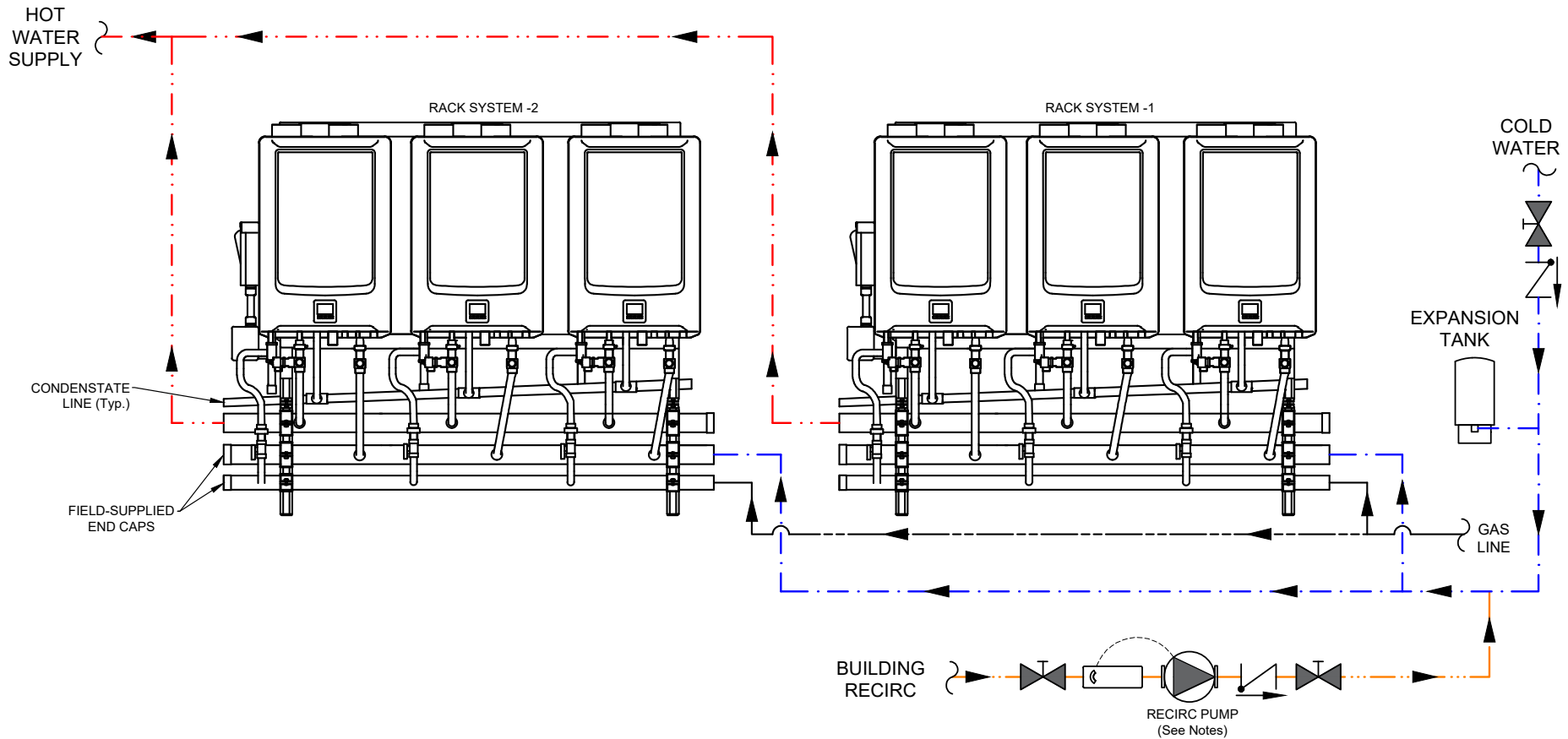



## PIPING DIAGRAM: TWO TANKLESS RACK SYSTEMS, EXTERNAL RE-CIRCULATION

This drawing is for reference only and shall not be used as an alternative to a professional engineered project drawing. Any use of this drawing is the responsibility of the party using it. Refer to local codes or building officials prior to installation.



**NOTES:**

- Unions are recommended on all water connections.
- Multiple rack systems should be piped in parallel or first-in/last-out (reverse/return) configuration.
- See rack system Manual for manifold pipe sizes.
- Recirc pump should be sized to meet a flow rate of 2.5 gpm per tankless at 25 ft. of head plus the total pressure drop from building loop.
- Recirc pump should be controlled by an aquastat and/or a timer.
- All gas heaters should be vented per Rheem guidelines. Venting is not shown in this schematic. It should be done in accordance with Use and care manual.
- Gas piping detail not shown in this drawing. Please refer to the Use & Care Manual and/or local codes for proper gas piping.
- Condensation drain is not shown. Please refer to Use & Care Manual and local codes for proper removal of condensation.

LEGEND	
	SHUT-OFF VALVE
	DRAIN
	CHECK VALVE
	PRESSURE RELIEF VALVE
	AQUA-STAT
	COLD WATER
	HOT WATER
	RE-CIRCULATION
	GAS LINE





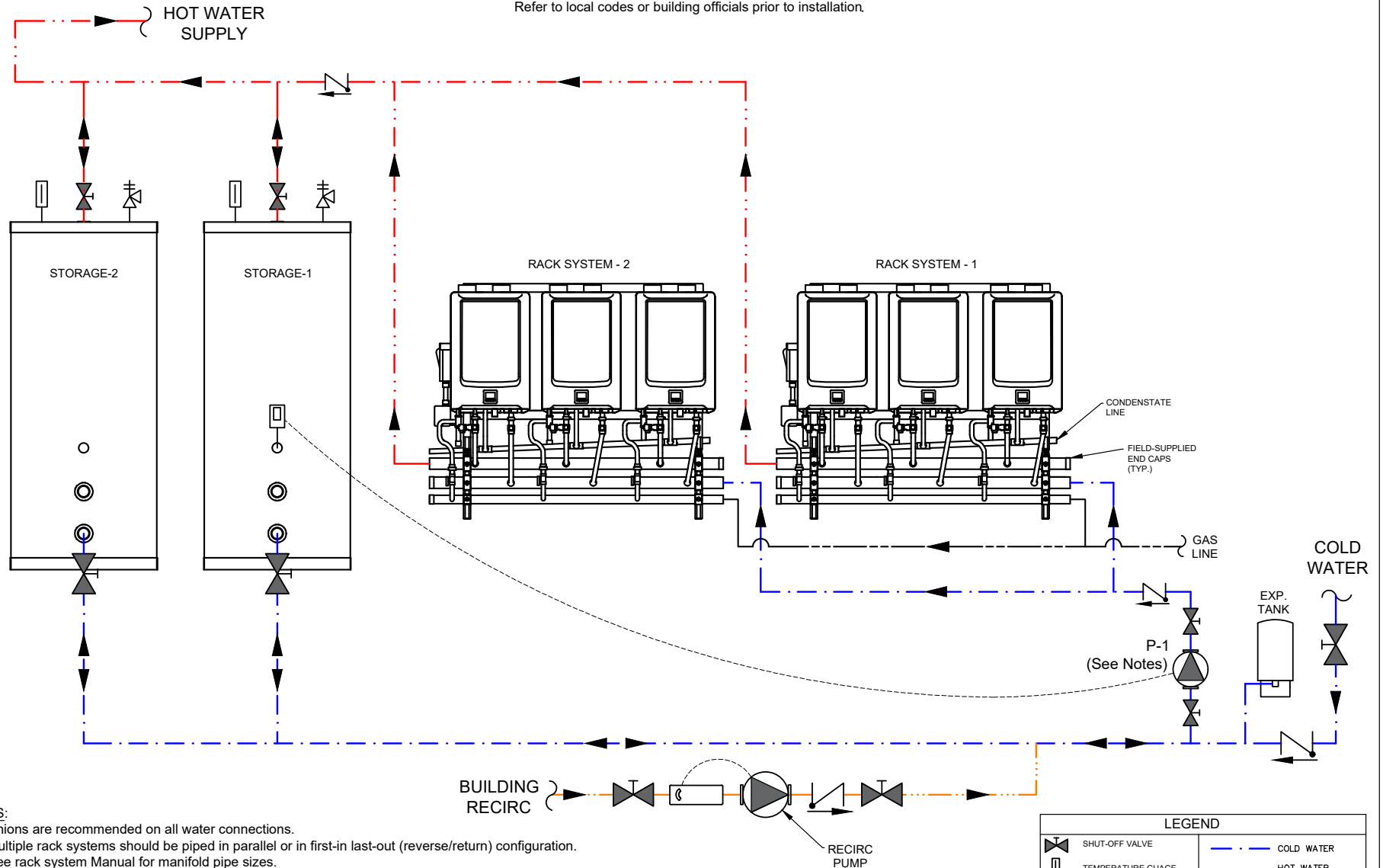





## PIPING DIAGRAM: TWO TANKLESS RACK SYSTEMS, TWO STORAGE TANKS, EXTERNAL RE-CIRCULATION

This drawing is for reference only and shall not be used as an alternative to a professional engineered project drawing. Any use of this drawing is the responsibility of the party using it. Refer to local codes or building officials prior to installation.

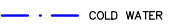

**NOTES:**

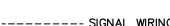
- Unions are recommended on all water connections.
- Multiple rack systems should be piped in parallel or in first-in last-out (reverse/return) configuration.
- See rack system Manual for manifold pipe sizes.
- P-1 pump controlled by tank-stat. P-1 pump selection based on total flow rate of tankless units at design delta T. Refer to specs for tankless unit(s) pressure drop at design flow rate.
- Building recirc pump should be controlled by an aqua-stat and/or a timer. Recirc pump sized to meet flow and pressure drop of building loop.
- All gas heaters should be vented per Rheem guidelines. Venting is not shown in this schematic. It should be done in accordance with Use and care manual.
- Gas piping detail not shown in this drawing. Please refer to the Use & Care Manual and/or local codes for proper gas piping.
- Condensation drain is not shown. Please refer to Use & Care Manual and local codes for proper removal of condensation.

LEGEND	
	SHUT-OFF VALVE
	TEMPERATURE GAUGE
	CHECK VALVE
	T & P RELIEF VALVE
	AQUA-STAT
	TANK-STAT
	COLD WATER
	HOT WATER
	RE-CIRCULATION
	GAS LINE
	SIGNAL WIRING



# Commercial Water

## Application Consulting

Put the power of our portfolio to work for you. Rheem Commercial Water is your source for any commercial hot water need. If you need assistance with sizing or product selection our teams of application engineers are ready to assist you.



### Project Consulting

Collaborate with experts who will provide specialized solutions tailored to meet your needs.



### Equipment Selection

We develop and maintain product application sizing charts for all commercial products.



### Piping Diagrams

2D and 3D support with creation of project quotes showing relevant specifications.



### Sizing Reports

Product application sizing and design solutions within 48 hours.



**Contact us now to get started.**

[www.rheem.com/commercial-hot-water-application-consulting/](http://www.rheem.com/commercial-hot-water-application-consulting/)

## Contact Us

Customer Service, Warranty, Parts  
**800.621.5622**

Technical Support – Tankless Gas  
**866.720.2076**

Plumber Business Support  
**1.866.339.2388**

Plumber Business Support Email  
**[PlumberBusinessSupport@Rheem.com](mailto:PlumberBusinessSupport@Rheem.com)**

Sizing & Selection Support – Rheem Engineering  
**[commercial.application@rheem.com](mailto:commercial.application@rheem.com)**

Visit us online at  
**[Rheem.com/Commercial-Tankless](http://Rheem.com/Commercial-Tankless)**  
or see your local distributor.