



Ruud High Efficiency Two-Stage Econet Enabled Air Handler



RH2V- Series

ECM Motor

Efficiencies up to 16 SEER



- The RH2V is EcoNet Enabled which allows direct communication with the Econet Smart Home System.
- Includes an energy efficient ECM[®] Motor, which in most applications, enhances the SEER rating of the outdoor unit. It also slowly ramps its speed up for quiet operation and enhanced customer satisfaction.
- Versatile 4-way convertible design for upflow, downflow, horizontal left and horizontal right applications.
- Nominal airflow up to 1.0" external static pressure.
- Factory-installed indoor coil.
- Sturdy cabinet construction with 1.0 inch [25.4 mm] of foil faced insulation for excellent sound and insulating characteristics.
- Field-installed auxiliary electric heater kits provide exact heat for indoor comfort. Kits include circuit breakers which meet U.L. and cUL requirements for service disconnect.
- Dip switch settings for selectable, customized cooling airflow over a wide variety of applications.
- On-demand dehumidification terminal that adjusts airflow to help control humidity for unsurpassed comfort in cooling mode.
- External filter required.
- Evaporator coil is constructed of aluminum fins bonded to internally grooved aluminum tubing.
- Cabinet air leakage less than 2% at 1 inch H₂O when tested in accordance with ASHRAE standard 193.

TABLE OF CONTENTS

Engineering Features	3
Model Number Identification	4
Dimensional Data	5-6
Airflow Directional Data	7
Airflow Performance Data (-)H2V	8-9
Electrical Data (-)H2V	10-11
Electrical Wiring	12
Limited Warranty	13

Engineering Features

RH2V- Series

- Equipped standard with an EcoNet® Air Handler control board that allows it to directly communicate with the EcoNet Smart Thermostat. The EcoNet Smart Thermostat serves as the hub of communication for a home's Heating, Cooling, and Water Heating systems, and is required to operate an EcoNet Enabled Heating and Cooling system in fully communicating mode. Built in WiFi enables remote operation of EcoNet Enabled equipment from the mobile-friendly web portal or mobile apps.
- Quiet, efficient ECM motor technology providing nominal airflow up to 1.0 inch [25 kPa] of external static pressure.
- Interface board with dip switches conveniently located in the blower compartment allows for precise, field selectable airflow to meet the requirements of particular applications.
- Selectable continuous fan "on" options.
- The most compact unit design available.
- Attractive pre-painted cabinet exterior.
- Rugged steel cabinet construction, designed for added strength and versatility.
- 1.0" foil faced insulation mechanically retained in blower compartment.
- Four leg rubber insulated motor mount.
- Field-installed auxiliary heater kit includes circuit breakers that meet UL and cUL requirements as a service disconnect switch.
- Blower housing with integrated controls, motor and blower. Slide out design for service and maintenance convenience.
- Field convertible for vertical upflow, vertical downflow, horizontal left hand or right hand air supply.
- Combustible floor base accessory available when required for downflow installations on combustible floors.
- Indoor coil design provides low air side pressure drop, high performance and extremely compact size. All coils come with PVC condensate elbow standard.
- Coils are constructed of aluminum fins bonded to internally grooved aluminum tubing.
- Coils are tested at the factory with an extensive refrigerant leak check.
- Coils have copper sweat refrigerant connections.
- Coils utilize chatleff metering device connections.
- Molded polymer corrosion resistant condensate drain pan is provided on all indoor coils.
- Supply duct flanges provided as standard on air handler cabinet.
- Provisions for field electrical connections available from either side or top of the air handler cabinet.
- Connection point for high voltage wiring is inside the air handler cabinet. Low voltage connection is made on the outside of the air handler cabinet.
- Concentric knockouts are provided for power connection to cabinet. Installer may pull desired hole size up to 2 inches [51 mm] for 1½ inch [38 mm] conduit.
- Front refrigerant and drain connections.

[] Designates Metric Conversions

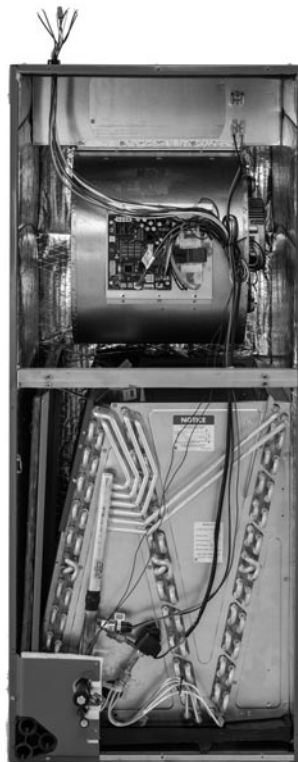

Model Number Identification
RH2V Series

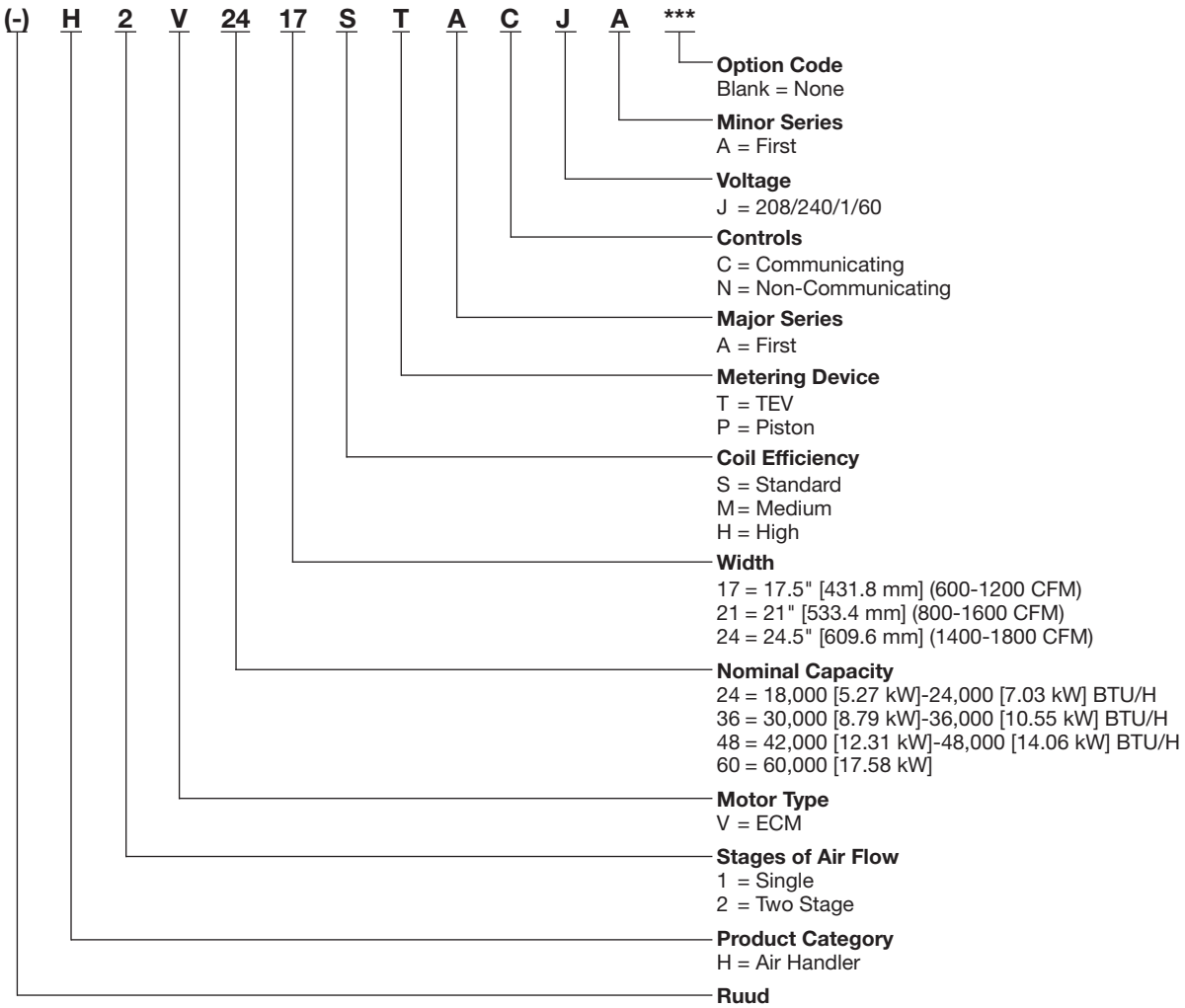

[] Designates Metric Conversions

Available Models
RH2V2417STACJA
RH2V2421MTACJA
RH2V3621MTACJA
RH2V4821MTACJA
RH2V6021STACJA
RH2V6024STACJA
RH2V6024MTACJA

Unit Dimensions

ELECTRICAL CONNECTIONS
MAY EXIT TOP OR EITHER SIDE
HIGH VOLTAGE CONNECTION 7/8" [22.2 mm],
1 3/32" [27.8 mm], 1 3/16" [50 mm] DIA, KNOCKOUTS.

LOW VOLTAGE CONNECTION
5/8" [15.9 mm] AND 7/8" [22.2 mm] KNOCKOUT

AUXILIARY DRAIN CONNECTION
3/4" [19.1 mm] FEMALE PIPE THREAD (NPT)
HORIZONTAL APPLICATION ONLY

PRIMARY DRAIN CONNECTION
3/4" [19.1 mm] FEMALE PIPE THREAD (NPT)

AUXILIARY DRAIN CONNECTION
3/4" [19.1 mm] FEMALE PIPE THREAD (NPT)
UPFLOW/DOWNFLOW APPLICATION ONLY

LIQUID LINE CONNECTION
COPPER (SWEAT)

VAPOR LINE CONNECTION
COPPER (SWEAT)

SUPPLY AIR ↑

NOTE: 24" CLEARANCE REQUIRED IN FRONT OF
UNIT FOR FILTER AND COIL MAINTENANCE.

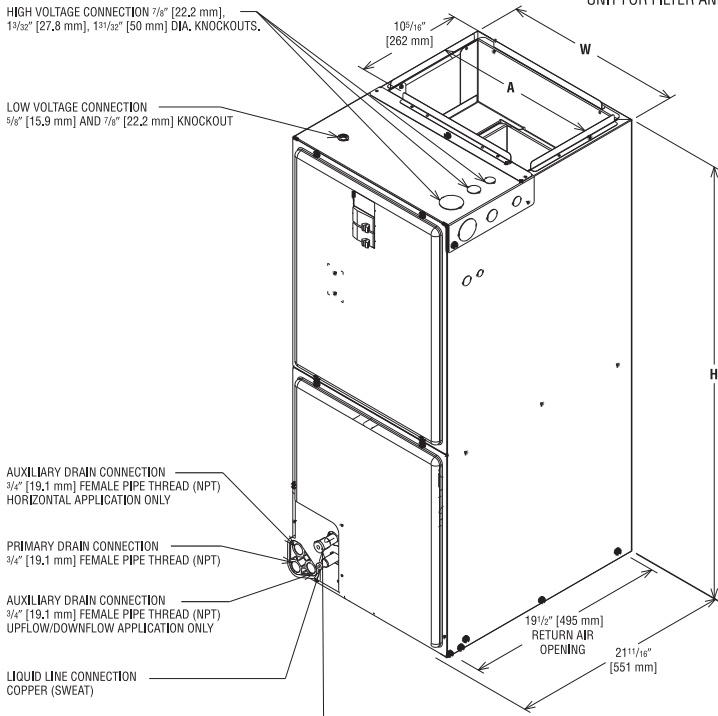

UPFLOW UNIT SHOWN:
UNIT MAY BE INSTALLED UPFLOW, DOWNFLOW,
HORIZONTAL RIGHT OR LEFT AIR SUPPLY.

Return Air Opening Dimensions

Model Cabinet Size	Return Air Opening Width (Inches)	Return Air Opening Depth/Length (Inches)
17	15 7/8	19 3/4
21	19 3/8	19 3/4
24	22 7/8	19 3/4

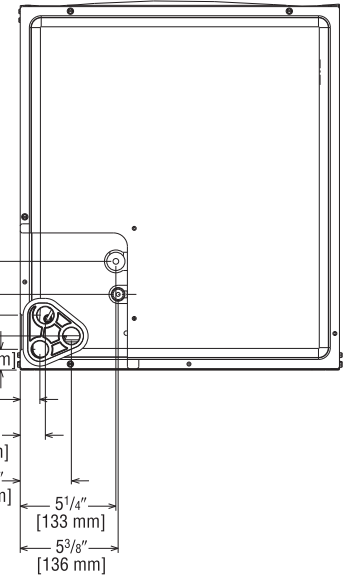

UPFLOW UNIT SHOWN:
UNIT MAY BE INSTALLED UPFLOW,
DOWNFLOW, HORIZONTAL RIGHT
OR LEFT AIR SUPPLY.

[] Designates Metric Conversions

HORIZONTAL ADAPTER KIT

VAPOR LINE CONNECTION

AUXILIARY HORIZONTAL DRAIN CONNECTION

PRIMARY DRAIN CONNECTION

AUXILIARY UPFLOW/DOWNFLOW DRAIN CONNECTION

LIQUID LINE CONNECTION

VERTICAL DRAIN PAN

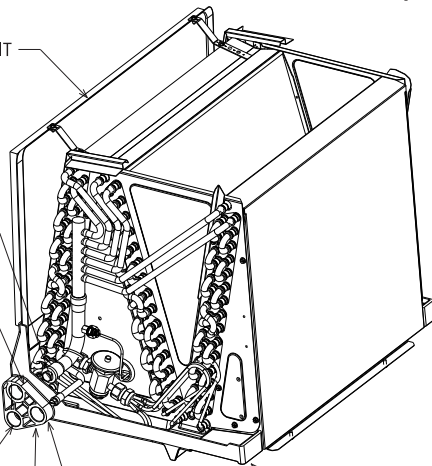

Unit Dimensions & Weights

Model Size RH2V	Refrigerant Connections Sweat (In.) [mm] ID		Unit Width "W" In. [mm]	Unit Height "H" In. [mm]	Supply Duct "A" In. [mm]	Air Flow Coil (Nom.) [L/s]		Unit Weight/Shipping Weight (Lbs.) [kg]
	Liquid	Vapor				Lo	Hi	Unit With Coil (Max. KW)
2417ST	3/8 [9.53]	3/4 [19.05]	17 1/2 [445]	42 1/2 [1080]	16 [406]	600 [283]	800 [378]	92/106 [42/48]
2421MT	3/8 [9.53]	3/4 [19.05]	21 [533]	42 1/2 [1080]	19 1/2 [495]	600 [283]	800 [378]	111/126 [50/57]
3621HT	3/8 [9.53]	7/8 [22.23]	21 [533]	57 [1448]	19 1/2 [495]	1000 [472]	1200 [566]	135/147 [61/67]
3621MT	3/8 [9.53]	7/8 [22.23]	21 [533]	50 1/2 [1282]	19 1/2 [495]	1000 [472]	1200 [566]	129/145 [59/66]
4821MT	3/8 [9.53]	7/8 [22.23]	21 [533]	57 [1448]	19 1/2 [495]	1400 [661]	1600 [755]	141/153 [64/69]
6021ST	3/8 [9.53]	7/8 [22.23]	21 [533]	57 [1448]	19 1/2 [495]	1600 [755]	1725 [814]	141/153 [64/69]
6024ST	3/8 [9.53]	7/8 [22.23]	24 1/2 [622]	55 1/2 [1410]	23 [584]	—	1800 [850]	162/179 [73/81]

*Maximum dehumidification airflow.

[] Designates Metric Conversions

Airflow Directional Data

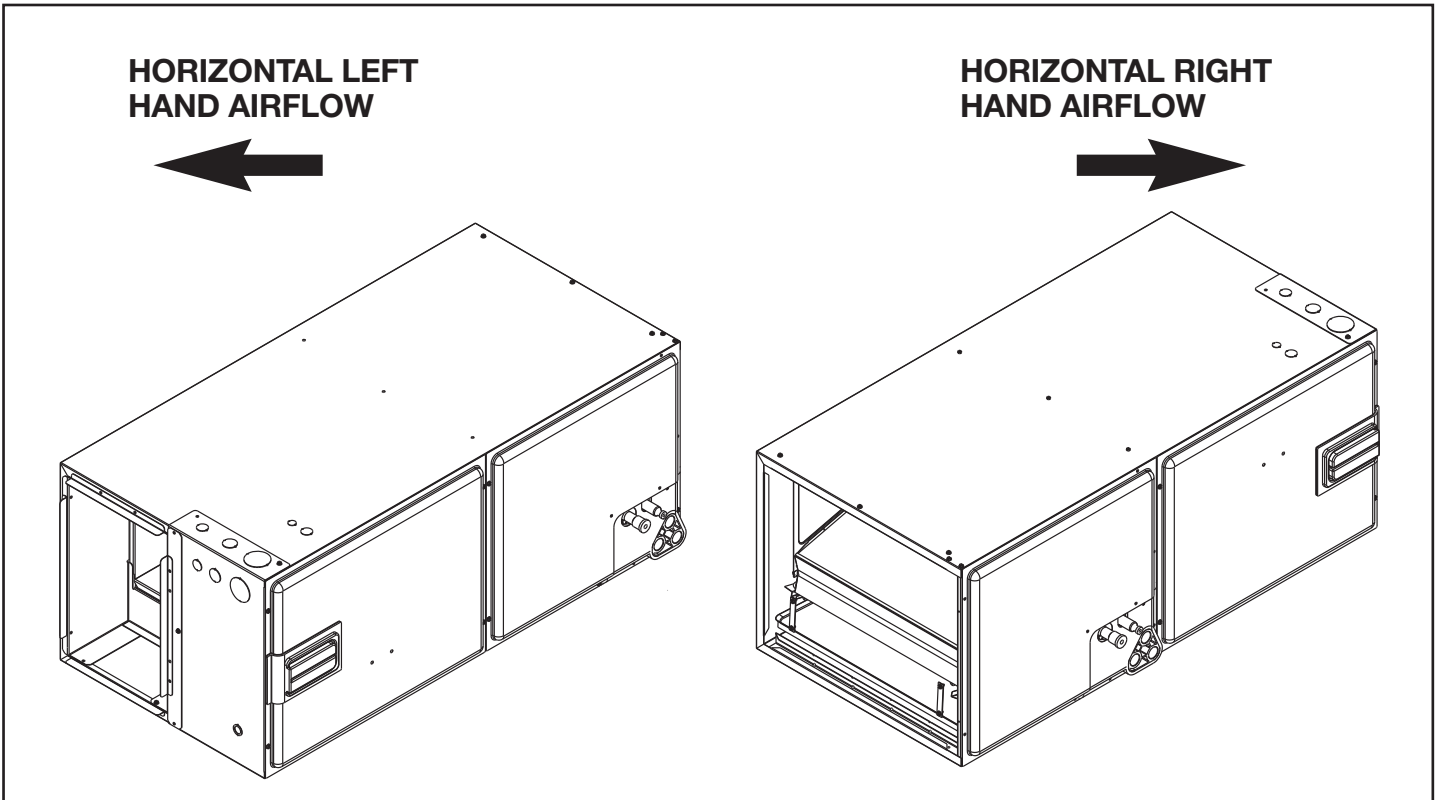
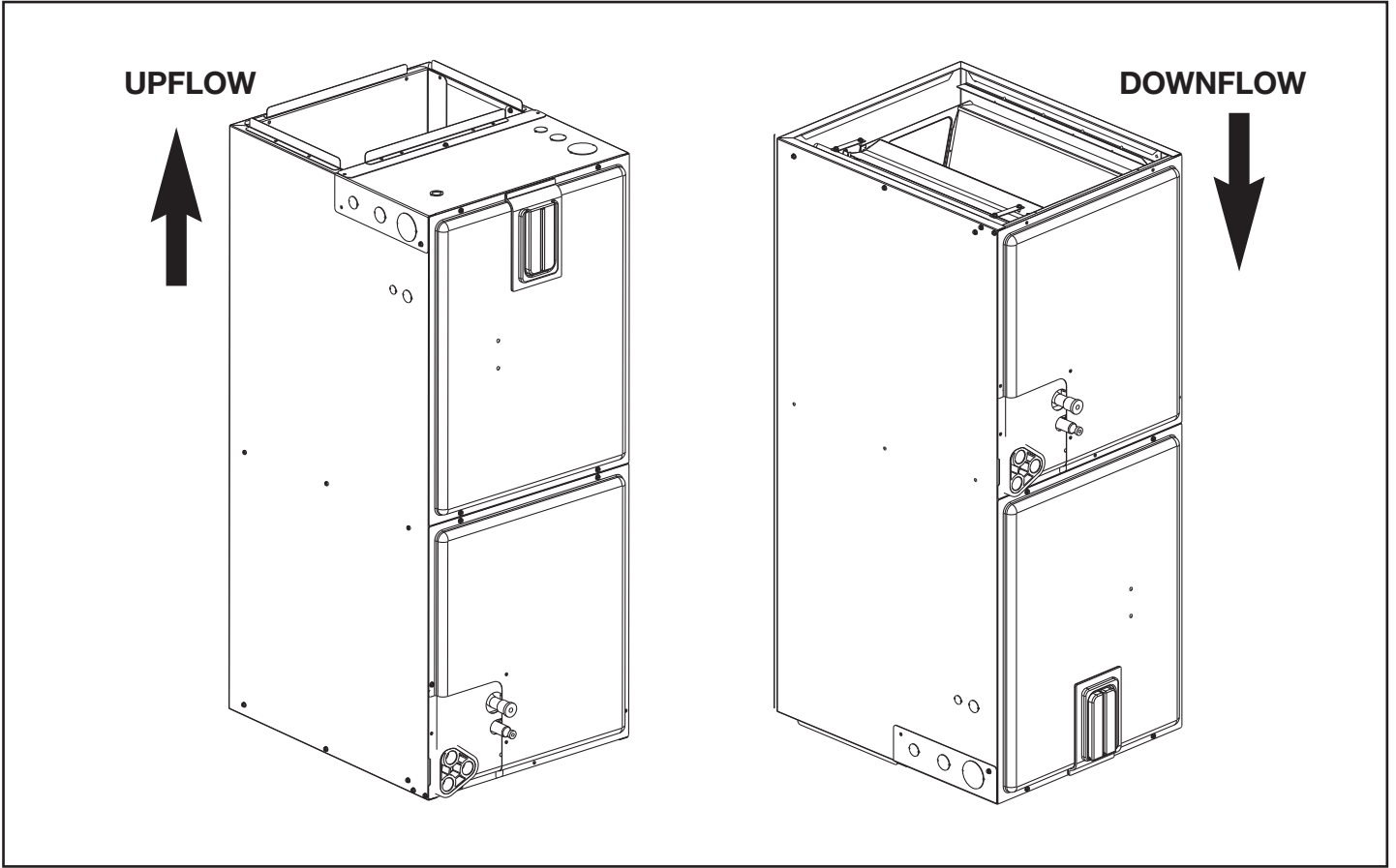

Airflow Performance

Airflow performance data is based on cooling performance with a coil and no filter in place. Select performance table for appropriate unit size, voltage and number of electric heaters to be used. Make sure external static applied to unit allows operation within the minimum and maximum limits shown in table

below for both cooling and electric heat operation. For optimum blower performance, operate the unit in the .3 [8 mm] to .7 inches [18 mm] W.C. external static range. Units with coils should be applied with a minimum of .1 inch [3 mm] W.C. external static range.

Airflow Performance Data RH2V

Model Size RH2V	Nominal Cooling Capacity Tons	Motor Speed From Factory	Nominal Airflow CFM	Blower Size Motor H.P.	CFM Air Delivery/RPM/Watts-230 Volts (No Filter)										
					External Static Pressure-Inches W.C.										
					0.10	0.20	0.30	0.40	0.50	0.60	0.70	0.80	0.90	1.00	
2417ST No Heat	1.5	High	600*	10x8 1/3	CFM	603	614	610	614	609	604	591	571	554	534
					RPM	515	608	679	758	816	880	935	989	1029	1081
					Watts	38	55	69	88	103	122	137	153	166	184
2417ST with 13kw Heater	1.5	High	600*	10x8 1/3	CFM	588	598	596	605	603	605	600	595	587	577
					RPM	536	608	723	805	864	919	989	1047	1104	1149
					Watts	65	85	100	129	145	160	186	209	233	254
2417ST No Heat	2	High	800	10x8 1/3	CFM	789	807	816	815	813	808	802	802	797	788
					RPM	594	678	743	804	871	922	973	1023	1076	1113
					Watts	71	94	113	133	157	176	198	221	248	269
2417ST with 13kw Heater	2	High	800	10x8 1/3	CFM	775	793	803	807	798	795	799	798	797	793
					RPM	630	700	783	839	891	941	997	1044	1098	1141
					Watts	111	130	165	192	219	240	275	298	332	357
2421MT No Heat	1.5	High	600*	10x8 1/3	CFM	597	608	607	616	616	618	613	608	600	594
					RPM	522	609	673	757	815	869	938	995	1051	1097
					Watts	57	74	89	115	130	144	169	190	212	232
2421ST with 13kw Heater	1.5	High	600*	10x8 1/3	CFM	588	598	596	605	603	605	600	595	587	577
					RPM	536	608	723	805	864	919	989	1047	1104	1149
					Watts	65	85	100	129	145	160	186	209	233	254
2421ST No Heat	2	High	800	10x8 1/3	CFM	787	805	815	819	810	807	811	810	809	805
					RPM	614	682	763	818	868	917	972	1017	1070	1112
					Watts	97	113	144	167	191	209	239	259	289	311
2421ST with 13kw Heater	2	High	800	10x8 1/3	CFM	775	793	803	807	798	795	799	798	797	793
					RPM	630	700	783	839	891	941	997	1044	1098	1141
					Watts	111	130	165	192	219	240	275	298	332	357
3617ST No heat	2.5	High	1000*	10x8 1/2	CFM	1001	1030	1030	1035	1035	1029	1029	1029	1029	1023
					RPM	652	752	812	845	923	945	1007	1065	1090	1118
					Watts	134	166	193	212	244	266	280	320	341	357
3617ST with 18kw heat	2.5	High	1000*	10x8 1/2	CFM	980	1009	1009	1014	1014	1008	1008	1008	1008	1002
					RPM	714	814	874	907	985	1007	1069	1127	1152	1180
					Watts	176	208	235	254	286	308	322	362	383	399
3617ST No heat	3.0	High	1200	10x8 1/2	CFM	1220	1229	1229	1229	1229	1229	1238	1238	1233	1228
					RPM	732	831	875	930	981	1005	1077	1108	1156	1194
					Watts	215	253	282	314	348	362	409	426	472	496
3617ST with 18kw heat	3.0	High	1200	10x8 1/2	CFM	1199	1208	1208	1208	1208	1208	1217	1217	1212	1207
					RPM	794	893	937	992	1043	1067	1139	1170	1218	1256
					Watts	257	295	3245	356	390	404	451	468	514	538

IMPORTANT: Observe airflow operating limits. Do not operate above 1.0 in. W.C. system external static.

*To obtain the nominal airflow 600 CFM for 2417, 1000 CFM for 3617, 1400 CFM for 4821, and 1600 CFM for 4824/6024; the DIP switches 1 and 2 must be set for selection C or D. See Figure 25.

[] Designates Metric Conversions

Airflow Performance Data RH2V (con't.)

Model Size RH2V	Nominal Cooling Capacity Tons	Motor Speed From Factory	Nominal Airflow CFM	Blower Size Motor H.P.	CFM Air Delivery/RPM/Watts-230 Volts (No Filter)										
					External Static Pressure-Inches W.C.										
					0.10	0.20	0.30	0.40	0.50	0.60	0.70	0.80	0.90	1.00	
3621MT with 15kw heat	2.5 ton	High	1000	10x10 3/4	CFM	984	979	984	976	967	956	947	939	910	901
					RPM	627	689	780	849	919	971	1041	1092	1128	1174
					Watts	124	151	187	215	250	273	312	347	366	394
3621MT No heat	3.0 ton	High	1200	10x10 3/4	CFM	1175	1200	1203	1200	1200	1199	1202	1200	1197	1180
					RPM	646	740	783	851	911	958	1013	1056	1102	1144
					Watts	147	186	207	240	270	296	334	356	385	416
3621MT with 18kw heat	3.0 ton	High	1200	10x10 3/4	CFM	1159	1178	1176	1167	1162	1155	1153	1145	1137	1114
					RPM	680	779	826	899	963	1015	1074	1122	1172	1219
					Watts	168	213	239	278	313	345	388	416	450	487
4821MT No heat	3.5 ton	High	1400	10x10 3/4 Hp	CFM	1393	1405	1410	1419	1422	1422	1419	1416	1407	1406
					RPM	769	830	886	958	1014	1069	1118	1152	1204	1232
					Watts	247	266	296	347	369	408	463	492	521	552
4821MT No heat	4	High	1600	10x10 3/4 Hp	CFM	1590	1605	1610	1625	1628	1628	1623	1620	1613	1599
					RPM	852	917	962	1034	1081	1132	1178	1220	1258	1292
					Watts	350	382	385	419	501	537	584	599	647	689
4821ST No heat	3.5	High	1400*	10x10 3/4	CFM	1395	1404	1413	1413	1411	1411	1402	1391	1380	1371
					RPM	731	807	859	910	968	1016	1057	1100	1128	1158
					Watts	240	273	308	349	383	411	436	468	496	513
4821ST with 20kw heat	3.5	High	1400*	10x10 3/4	CFM	1379	1382	1386	1380	1373	1367	1353	1336	1320	1305
					RPM	765	846	902	958	1020	1073	1118	1166	1198	1233
					Watts	261	300	340	387	426	460	490	528	561	584
4821ST No heat	4.0	High	1600	10x10 3/4	CFM	1583	1583	1583	1590	1582	1566	1572	1556	1547	1539
					RPM	826	879	933	984	1025	1067	1119	1148	1176	1219
					Watts	342	375	410	454	486	523	552	585	614	616
4821ST with 25kw heat	4.0	High	1600	10x10 3/4	CFM	1567	1559	1551	1550	1534	1511	1509	1485	1468	1452
					RPM	860	919	978	1035	1082	1129	1187	1222	1255	1304
					Watts	363	403	444	495	534	577	613	653	688	697
4824ST No heat	4.0	High	1600*	11x11 3/4	CFM	1607	1615	1622	1630	1637	1629	1621	1614	1606	1583
					RPM	612	698	747	788	835	870	914	950	981	1018
					Watts	225	297	334	359	410	439	469	502	532	568
4824ST with 25kw heat	4.0	High	1600*	11x11 3/4	CFM	1587	1589	1589	1591	1591	1577	1562	1549	1534	1505
					RPM	658	748	802	847	899	938	987	1027	1063	1104
					Watts	246	325	369	401	459	495	532	572	609	652
6021ST No heat	4 & 5	High	1600	10x10 3/4 Hp	CFM	1584	1593	1597	1593	1590	1591	1583	1576	1554	1456
					RPM	917	972	1027	1071	1117	1164	1223	1260	1304	1331
					Watts	340	381	420	453	490	529	579	606	641	636
6021ST No heat	5	High	1700	10x10 3/4 Hp	CFM	1669	1680	1686	1702	1703	1699	1687	1686	1677	1666
					RPM	882	946	995	1059	1107	1152	1181	1230	1249	1294
					Watts	379	394	442	485	541	598	610	659	679	723
6024ST No heat	4.0 & 5.0	High	1600*	11x11 3/4	CFM	1607	1615	1622	1630	1637	1629	1621	1614	1606	1583
					RPM	612	698	747	788	835	870	914	950	981	1018
					Watts	225	297	334	359	410	439	469	502	532	568
6024ST with 25kw heat	4.0 & 5.0	High	1600*	11x11 3/4	CFM	1587	1589	1589	1591	1591	1577	1562	1549	1534	1505
					RPM	658	748	802	847	899	938	987	1027	1063	1104
					Watts	246	325	369	401	459	495	532	572	609	652
6024ST No heat	5.0	High	1800	11x11 3/4	CFM	1794	1808	1808	1808	1807	1807	1807	1800	1786	1772
					RPM	676	739	787	840	871	923	950	994	1028	1050
					Watts	330	376	416	465	504	554	576	624	662	694
6024ST with 30kw heat	5.0	High	1800	11x11 3/4	CFM	1756	1770	1770	1769	1769	1769	1769	1762	1748	1734
					RPM	713	778	828	884	917	971	1000	1047	1083	1107
					Watts	361	410	453	505	547	600	625	676	717	752

*To obtain the nominal airflow 600 CFM for 2417, 1000 CFM for 3617, 1400 CFM for 4821, and 1600 CFM for 4824/6024; the DIP switches 1 and 2 must be set for selection C or D. See Figure 25.

Electrical Data (-)H2V

Model (-)H2V	Voltage	Phase	Hertz	HP	RPM	Circuit Amps	Minimum Circuit Ampacity	Maximum Overcurrent Protection
2417S	208/240	1	60	1/3	300-1100	1.7	3.0	15
2421M	208/240	1	60	1/3	300-1100	1.7	3.0	15
3621M	208/240	1	60	3/4	300-1100	4.9	7.0	15
4821M/6021S	208/240	1	60	3/4	300-1100	4.9	7.0	15
6024S/6024M	208/240	1	60	3/4	300-1100	4.9	7.0	15

Electrical Data – With Electric Heat RH2V

Installation of the U.L. Listed original equipment manufacturer provided heater kits listed in the following table is recommended for all auxiliary heating requirements.

Model Size (-)H2V	Manufacturer Model Number	Heater kW (208/240)	PH/HZ	No. Elements kW Per	Type Supply Circuit	Circuit Amps.	Motor Ampacity	Minimum Circuit Ampacity	Maximum Overcurrent Protection
2417S	RXBH-17?03J	2.25/3.0	1/60	1-3.0	SINGLE	10.8/12.5	2.9	16/18	20/20
2417S 2421M	RXBH-1724?03J	2.25/3.0	1/60	1-3.0	SINGLE	10.8/12.5	2.9	16/18	20/20
	RXBH-1724?05J	3.6/4.8	1/60	1-4.8	SINGLE	17.3/20.0	2.9	24/28	25/30
	RXBH-1724?07J	5.4/7.2	1/60	2-3.6	SINGLE	26.0/30.0	2.9	35/40	35/40
	RXBH-1724?10J	7.2/9.6	1/60	2-4.8	SINGLE	34.6/40.0	2.9	46/53	50/60
2421H	RXBH-1724?03J	2.25/3.0	1/60	1-3.0	SINGLE	10.8/12.5	3.4	18/20	20/20
	RXBH-1724?05J	3.6/4.8	1/60	1-4.8	SINGLE	17.3/20.0	3.4	26/28	30/30
	RXBH-1724?07J	5.4/7.2	1/60	2-3.6	SINGLE	26.0/30.0	3.4	37/42	40/45
	RXBH-1724?10J	7.2/9.6	1/60	2-4.8	SINGLE	34.6/40.0	3.4	48/55	50/60
2421U	RXBH-1724?03J	2.25/3.0	1/60	1-3.0	SINGLE	10.8/12.5	4.9	19/21	20/25
	RXBH-1724?05J	3.6/4.8	1/60	1-4.8	SINGLE	17.3/20.0	4.9	28/32	30/35
	RXBH-1724?07J	5.4/7.2	1/60	2-3.6	SINGLE	26.0/30.0	4.9	39/44	40/45
	RXBH-1724?10J	7.2/9.6	1/60	2-4.8	SINGLE	34.6/40.0	4.9	50/57	50/60
3617S	RXBH-17?03J	2.25/3.0	1/60	1-3.0	SINGLE	10.8/12.5	3.4	18/20	20/20
	RXBH-1724?03J	2.25/3.0	1/60	1-3.0	SINGLE	10.8/12.5	3.4	18/20	20/20
	RXBH-1724?05J	3.6/4.8	1/60	1-4.8	SINGLE	17.3/20.0	3.4	26/29	30/30
	RXBH-1724?07J	5.4/7.2	1/60	2-3.6	SINGLE	26.0/30.0	3.4	37/42	40/45
	RXBH-1724?10J	7.2/9.6	1/60	2-4.8	SINGLE	34.6/40.0	3.4	48/54	50/60
	RXBH-1724A15J	10.8/14.4	1/60	3-4.8	SINGLE	51.9/60.0	3.4	70/80	70/80
		3.6/4.8	1/60	1-4.8	MULTIPLE CKT 1	17.3/20.0	3.4	26/30	30/30
		7.2/9.6	1/60	2-4.8	MULTIPLE CKT 2	34.6/40.0	0	44/50	45/50
	RXBH-1724A18J	12.8/17.0	1/60	3-5.68	SINGLE	61.6/70.8	3.4	82/93	90/100
		4.3/5.7	1/60	1-5.68	MULTIPLE CKT 1	20.5/23.6	3.4	30/34	30/35
8.5/11.3		1/60	2-5.68	MULTIPLE CKT 2	41.1/47.2	0	52/59	60/60	

NOTES:

- * Values only. No single point kit available.
- Electric heater BTUH - (heater watts + motor watts) × 3.414 (see airflow table for motor watts).
- Supply circuit protective devices may be fuses or "HACR" type circuit breakers.
- Motor load is included in single circuit and multiple circuit 1.
- Heater loads are balanced on 3 phase heater kits with 3 or 6 heating elements only.

- J Voltage (230V) single phase air handler is designed to be used with single or three phase 230 volt electric heaters. To connect 3-phase power to the air handler terminal block, bring only two leads to the terminal block, cap, insulate, and fully secure the third lead.
- If the kit is listed under both single and multiple circuits, the heater kit is shipped from factory as multiple circuits. For single phase applications, Jumper bar kit RXBJ-A21 and RXBJ-A31 can be used to convert multiple circuits to a single supply circuit. See Section 6.2 for details.
- The airflow for continuous fan is set 50% of the cooling airflow..

[] Designates Metric Conversions

Electrical Data – With Electric Heat RH2V (con't.)

Installation of the U.L. Listed original equipment manufacturer provided heater kits listed in the following table is recommended for all auxiliary heating requirements.

Model Size (-)H2V	Manufacturer Model Number	Heater kW (208/240V)	PH/HZ	No. Elements kW Per	Type Supply Circuit	Circuit Amps.	Motor Ampacity	Minimum Circuit Ampacity	Maximum Overcurrent Protection	
3621M 4821M 6021S	RXBH-1724705J	3.6/4.8	1/60	1-4.8	SINGLE	17.3/20.0	4.9	28/32	30/35	
	RXBH-1724707J	5.4/7.2	1/60	2-3.6	SINGLE	26.0/30.0	4.9	39/44	40/45	
	RXBH-1724710J	7.2/9.6	1/60	2-4.8	SINGLE	34.6/40.0	4.9	50/57	50/60	
	RXBH-1724A15J	10.8/14.4	1/60	3-4.8	SINGLE	51.9/60.0	4.9	72/82	80/90	
		3.6/4.8	1/60	1-4.8	MULTIPLE CKT 1	17.3/20.0	4.9	28/32	30/35	
		7.2/9.6	1/60	2-4.8	MULTIPLE CKT 2	34.6/40.0	4.9	44/50	45/50	
	RXBH-1724A18J	12.8/17.0	1/60	3-5.68	SINGLE	61.6/70.8	4.9	84/95	90/100	
		4.3/5.7	1/60	1-5.68	MULTIPLE CKT 1	20.5/23.6	4.9	32/36	35/40	
		8.5/11.3	1/60	2-5.68	MULTIPLE CKT 2	41.1/47.2	0	52/59	60/60	
	RXBH-24A20J 4821/6021 only	14.4/19.2	1/60	4-4.8	SINGLE	69.2/80	4.9	93/107	100/110	
		7.2/9.6	1/60	2-4.8	MULTIPLE CKT 1	34.6/40.0	4.9	50/57	50/60	
		7.2/9.6	1/60	2-4.8	MULTIPLE CKT 2	34.6/40.0	0	44/50	45/50	
	RXBH-24A25J 4821/6021 only	18.0/24.0	1/60	6-4.0	SINGLE	86.4/99.9	4.9	115/132	125/150	
		6.0/8.0	1/60	2-4.0	MULTIPLE CKT 1	28.8/33.3	4	43/48	45/50	
		6.0/8.0	1/60	2-4.0	MULTIPLE CKT 2	28.8/33.3	0	37/42	40/45	
		6.0/8.0	1/60	2-4.0	MULTIPLE CKT 3	28.8/33.3	0	37/42	40/45	
	6024M	RXBH-1724705J	3.6/4.8	1/60	1-4.8	SINGLE	17.3/20.0	4.9	28/32	30/35
		RXBH-1724707J	5.4/7.3	1/60	2-3.6	SINGLE	26.0/30.0	4.9	39/44	40/45
RXBH-1724710J		5.4/7.2	1/60	2-4.8	SINGLE	26.0/30.0	4.9	39/44	40/45	
RXBH-1724A15J		10.8/14.4	1/60	3-4.8	SINGLE	51.9/60.0	4.9	72/82	80/90	
		3.6/4.8	1/60	1-4.8	MULTIPLE CKT 1	17.3/20.0	4.9	28/32	30/35	
		7.2/9.6	1/60	2-4.8	MULTIPLE CKT 2	34.6/40.0	0	44/50	45/50	
RXBH-1724A18J		12.8/17	1/60	3-5.68	SINGLE	61.6/70.8	4.9	84/95	90/100	
		4.3/5.7	1/60	1-5.68	MULTIPLE CKT 1	20.5/23.6	4.9	35/40	32/36	
		8.5/11.3	1/60	2-5.68	MULTIPLE CKT 2	41.1/47.2	0	60/60	52/59	
RXBH-24A20J		14.4/19.2	1/60	4-4.8	SINGLE	69.2/80.0	4.4	93/107	100/110	
		7.2/9.6	1/60	2-4.8	MULTIPLE CKT 1	34.6/40.0	4.4	50/57	50/60	
		7.2/9.6	1/60	2-4.8	MULTIPLE CKT 2	34.6/40.0	0	44/50	45/50	
RXBH-24A25J		18.0/24.0	1/60	6-4.0	SINGLE	87.0/99.9	4.9	115/132	125/150	
		6.0/8.0	1/60	2-4.0	MULTIPLE CKT 1	29.0/33.3	4.9	43/48	45/50	
		6.0/8.0	1/60	2-4.0	MULTIPLE CKT 2	29.0/33.3	0	37/42	40/45	
		6.0/8.0	1/60	2-4.0	MULTIPLE CKT 3	29.0/33.3	0	37/42	40/45	
RXBH-24A30J 1800 CFM only		21.6/28.8	1/60	4-8.6	SINGLE	103.8/120.0	4.9	150/175	136/156	
		7.2/9.6	1/60	2-4.8	MULTIPLE CKT 1	34.6/40.0	4.9	50/60	49/56	
	2-4.8	1/60	2-4.8	MULTIPLE CKT 2	34.6/40.0	0	45/50	44/50		
	7.2/9.6	1/60	2-4.8	MULTIPLE CKT 3	34.6/40.0	0	45/50	44/50		

NOTES:

- * Values only. No single point kit available.
- Electric heater BTUH - (heater watts + motor watts) × 3.414 (see airflow table for motor watts.)
- Supply circuit protective devices may be fuses or "HACR" type circuit breakers.
- Motor load is included in single circuit and multiple circuit 1.
- Heater loads are balanced on 3 phase heater kits with 3 or 6 heating elements only.

- J Voltage (230V) single phase air handler is designed to be used with single or three phase 230 volt electric heaters. To connect 3-phase power to the air handler terminal block, bring only two leads to the terminal block, cap, insulate, and fully secure the third lead.
- If the kit is listed under both single and multiple circuits, the heater kit is shipped from factory as multiple circuits. For single phase applications, Jumper bar kit RXBJ-A21 and RXBJ-A31 can be used to convert multiple circuits to a single supply circuit. See Section 6.2 for details.
- The airflow for continuous fan is set 50% of the cooling airflow..

[] Designates Metric Conversions

Electrical Wiring

Power Wiring

- Field wiring must comply with the National Electrical Code (C.E.C. in Canada) and any applicable local ordinance.
- Supply wiring must be 75°C minimum copper conductors only.
- See electrical data for product Ampacity rating and Circuit Protector requirement.

Accessories

• Combustible Floor Base RXHB-

Model Cabinet Size	Combustible Floor Base Model Number
17	RXHB-17
21	RXHB-21
24	RXHB-24

- **Jumper Bar Kit 3 Ckt. to 1 Ckt. RXBJ-A31** is used to convert single phase multiple three circuit units to a single supply circuit. Kit includes cover and screw for line side terminals.
- **Jumper Bar Kit 2 Ckt. to 1 Ckt. RXBJ-A21** is used to convert single phase multiple two circuit units to a single supply circuit. Kit includes cover and screw for line side terminals.
- **Note:** No jumper bar kit is available to convert three phase multiple two circuit units to a single supply circuit.
- **Auxiliary Horizontal Overflow Pan Accessory RXBM-**

Nominal Cooling Capacity-Tons	Auxiliary Horizontal Overflow Pan Accessory Model Number
1 ¹ / ₂ - 3	RXBM-AC48
3 ¹ / ₂ - 5	RXBM-AC61

Grounding

- This product must be sufficiently grounded in accordance with National Electrical Code (C.E.C. in Canada) and any applicable local ordinance.
- A grounding lug is provided.

• Auxiliary Electric Heater Kits RXBH-

Heater Kits include circuit breakers which meet UL and cUL requirements for service disconnect. See the Electric Heat Electrical Data in this specification sheet for specific Heater Kit Model numbers.

• Horizontal Adapter Kit RXHH-

This horizontal adapter kit is used to convert Upflow/Downflow only models to horizontal flow. See the following table to order proper horizontal adapter kit.

Coil Model	Horizontal Adapter Kit Model Number (Single Qty.)	Horizontal Adapter Kit Model Number (10-Pack Qty.)
2414	RXHH-A01	RXHH-A01 x 10
2417	RXHH-A02	RXHH-A02 x 10
3617/3621	RXHH-A03	RXHH-A03 x 10
3821/4821/4824	RXHH-A04	RXHH-A04 x 10
3621HT/4821MT/6021ST	RXHH-06	RXHH-06 x 10
6024	RXHH-A05	RXHH-A05 x 10

• External Filter Base RXHF-

Model Cabinet Size	Filter Size In. [mm]	Part Number*	A	B
17	16 x 20 [406 x 508]	RXHF-17	15.70	17.5
21	20 x 20 [508 x 508]	RXHF-21	19.20	21.0
24	25 x 20 [635 x 508]	RXHF-24	22.70	25.5

*Accommodates 1" or 2" filter

[] Designates Metric Conversions

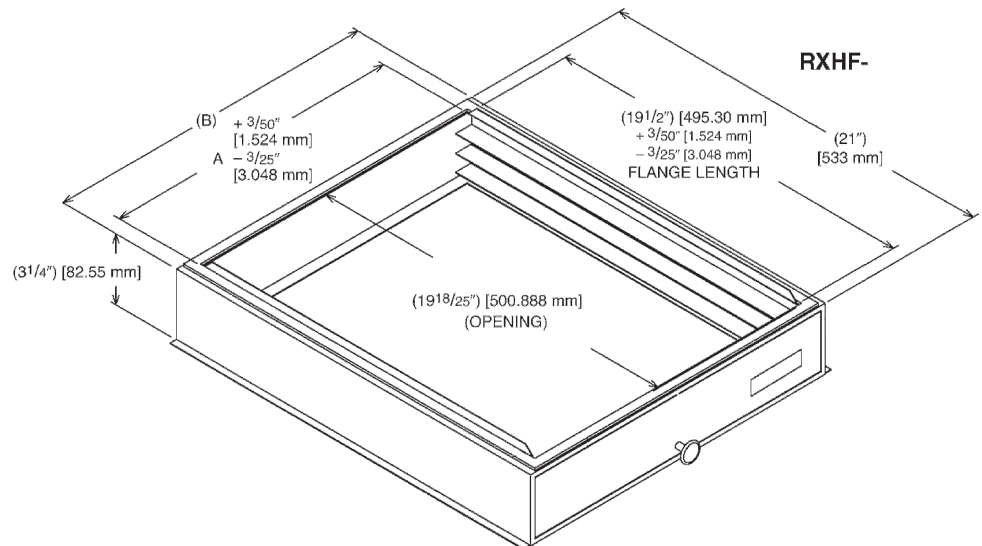
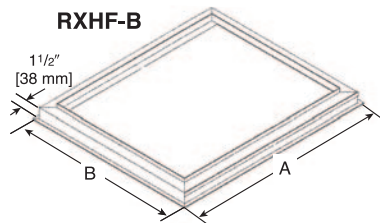

GENERAL TERMS OF LIMITED WARRANTY*

Ruud will furnish a replacement for any part of this product which fails in normal use and service within the applicable periods stated, in accordance with the terms of the limited warranty.

Parts.....Ten (10) Years

***For complete details of the Limited and Conditional Warranties, including applicable terms and conditions, contact your local contractor or the Manufacturer for a copy of the product warranty certificate.**



In keeping with its policy of continuous progress and product improvement, Ruud reserves the right to make changes without notice.

Ruud Heating, Cooling & Water Heating • 5600 Old Greenwood Road
Fort Smith, Arkansas 72908 • www.ruud.com

Ruud Canada • 125 Edgeware Road, Unit 1
Brampton, Ontario • L6Y 0P5

RELY ON RUUD.™

PRINTED IN U.S.A. 1/20 QG FORM NO. H22-563