



The new degree of comfort®



Commercial Electric
Booster Water Heaters

Electric boosters are designed to fit under counters and deliver sanitizing rinse water for all stationary rack and conveyor type commercial dishwashers

Features & Benefits

Our 10 gallon electric booster will raise preheated or cold water to 180° F rinse temperature for compliance with UL sanitation (NSF5) and all federal, state, county and local health department sanitation codes. In addition, these models can be used as circulating tank commercial electric water heaters for gravity or pump circulation to an auxiliary storage tank. They are available in 6 kW through 54 kW and in 208, 240, 277 and 480 voltages.

System Sentinel

All electric booster models employ an element diagnostic panel, utilizing light emitting diodes (L.E.D.), corresponding to the number and location of each heating element. L.E.D.'s are energized when the electric elements are operating. An unlit L.E.D. pinpoints the exact location of a non-functioning element, making element operation diagnosis simple and positive.

Long Life Tank Design

Proprietary steel formulation with a unique coat of high temperature porcelain enamel maximizes corrosion resistance resulting in a superior tank design.

Long Life Heating Elements

Separate screw-in type elements feature a Nichrome wire filament, embedded in magnesium oxide sealed in a copper tube to resist water chemical corrosion...for long element life and a long life performance. Elements are directly immersed in the water for maximum recovery efficiency (98%) and are easily changed by simply screwing new ones into the tank.

Integral Fusing

All models have integral fusing for each element.

Anode rods

Two (2) magnesium anodes are installed in each tank for maximum corrosion resistance.

CSA/ASME Rated T&P Valve

Factory installed relief valve

Electrical Connections

Pre-wired, accessible control box with multiple knock-outs on side in size selections to match the National Electric Code. Sizes range from 1/2" to 2". A grounding screw is provided for attaching an equipment grounding conductor.

Single Panel Control Box

It comes with hinged stainless steel door that provides immediate access to all electrical components and elements.

Terminal Block

All models are equipped with UL Listed terminal blocks for simplicity of installation. The terminal block will accept either copper or aluminum field connect wire.

120 Volt Control Circuit

All units are furnished with a fused 120 volt control circuit. All controls (thermostats, high temperature limit, etc.) are operated off of this basic 120 volt control circuit. This circuit is created by an internal multi-tap transformer of unique design that has four (4) taps for the primary voltages, 208, 240, 277 and 480.

Warranty

3-Year limited tank warranty

See Commercial Warranty Certificate for complete information.

Safety and Construction | Design certified by Underwriters Laboratories (UL) to meet UL standard 1453 as electric booster and commercial storage tank water heaters. All models are UL Sanitation (NSF5).
Certified for 150 PSI maximum working pressure.



Rheem Booster

10-Gallon Capacity
6kW-54kW
208, 240, 277 and 480 Voltages



Continued next page



INTEGRATED AIR & WATER

Water Connections

Hot outlet and cold inlet are 1-1/4" NPT dielectric nipples which prevent excessive turbulence of heated water and results in optimum tank draw.

Heavy Insulation

an effective blanket of insulation completely surrounds tanks to limit heat loss and assure high operating efficiency.

Stainless steel legs

6" stainless steel legs are provided with each unit.

Factory Accessories from Rheem

Solid state low water cut-off: probe type cut-off for field installation (AP8408).

Fuse Type

The "G" in the model number represents Class G fuses.

Fuseless Constructions

Any standard model not exceeding 48 Amps (See "Electrical Characteristics" Table) may be ordered without element fuses. Add "N" after the fuse type designation.

Example: E10-9-G becomes E10-9-GN

Approximate Shipping Weight

110 lbs./50 kgs.

MODEL NUMBERS	INPUT KW
E10-6-G	6
E10-9-G	9
E10-12-G	12
E10-15-G	15
E10-18-G	18
E10-24-G	24
E10-27-G	27
E10-30-G	30
E10-36-G	36
E10-45-G	45
E10-54-G	54

WATER TEMPERATURE RATINGS					
MODEL NUMBER	TANK CAPACITY	THERMOSTAT TYPE	MINIMUM DELIVERED TEMPERATURE	MAXIMUM DELIVERED TEMPERATURE	HIGH TEMPERATURE LIMIT
E10	10 Gal./ 38L	Immersion	90°F / 32.2°C	190°F / 87.8°C	200°F / 93.3°C

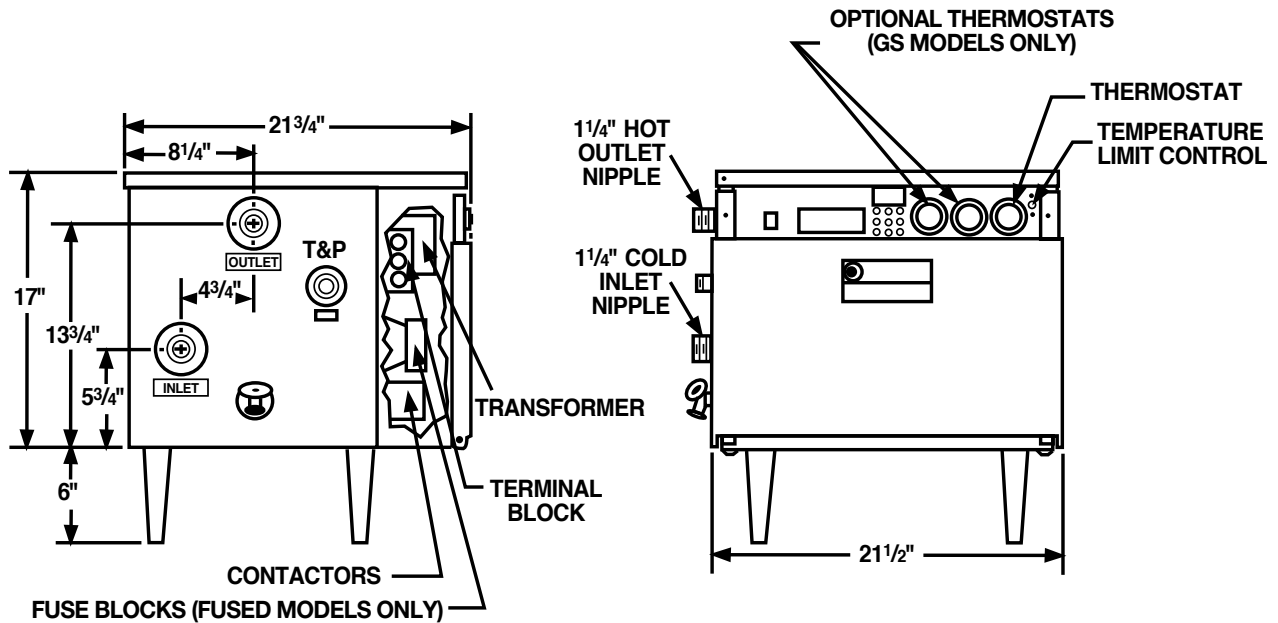

ELECTRICAL CHARACTERISTICS											
INPUT KW	NUMBER OF ELEMENTS	ELEMENT WATTAGE	FULL LOAD CURRENT IN AMPERES							IMMERSION THERMOSTATS	
			208V		240V		277V	480V		NUMBER OF CONTACTORS	NUMBER OF FUSES
			PHASE		Phase		PHASE	PHASE			
			1	3	1	3	1	1	3		
6	3	2000	29	17	25	14	22	13	7	2	6
9	3	3000	43	25	38	22	33	19	11	2	6
12	3	4000	58	33	50	29	43	25	15	2	6
15	3	5000	72	42	63	36	54	31	18	2	6
18	3	6000	-	-	75	43	65	38	22	2	6
18	6	3000	87	50	-	-	-	-	-	4	12
24	6	4000	116	67	100	58	87	50	29	4	12
27	6	4500	130	75	113	65	98	56	33	4	12
30	6	5000	144	84	125	73	108	63	36	4	12
36	6	6000	-	-	150	87	130	75	43	4	12
36	9	4000	173	100	-	-	-	-	-	6	18
45	9	5000	217	125	188	109	163	94	54	6	18
54	9	6000	260	150	225	130	195	113	65	6	18

RECOVERY CAPACITIES														
Recovery in U.S. Gallons/Hr. (GPH) and Liters/Hr. (LPH) at Various Temperature Rises														
INPUT KW	EQUIVALENT BTU/H	UNITS	40°F (22°C)	50°F (28°C)	60°F (33°C)	70°F (39°C)	80°F (45°C)	90°F (50°C)	100°F (56°C)	110°F (61°C)	120°F (67°C)	130°F (72°C)	140°F (78°C)	
6	20,473	GPH	62	50	41	35	31	28	25	23	21	19	18	
		LPH	235	188	157	134	117	104	94	85	78	72	67	
9	30,710	GPH	93	74	62	53	47	41	37	34	31	29	27	
		LPH	352	282	235	201	176	157	141	128	117	108	101	
12	40,946	GPH	124	99	83	71	62	55	50	45	41	38	35	
		LPH	470	376	313	268	235	209	188	171	157	145	134	
15	51,183	GPH	155	124	103	89	78	69	62	56	52	48	44	
		LPH	587	470	391	335	294	261	235	213	196	181	168	
18	61,420	GPH	186	149	124	106	93	83	74	68	62	57	53	
		LPH	705	564	470	403	352	313	282	256	235	217	201	
24	81,893	GPH	248	199	165	142	124	110	99	90	83	76	71	
		LPH	939	751	626	537	470	417	376	342	313	289	268	
27	92,129	GPH	279	223	186	160	140	124	112	102	93	86	80	
		LPH	1057	845	705	604	548	470	423	384	352	325	302	
30	102,366	GPH	310	248	207	177	155	138	124	113	103	95	89	
		LPH	1174	939	783	671	587	522	470	427	391	361	335	
36	122,839	GPH	372	298	248	213	186	165	149	135	124	115	106	
		LPH	1409	1127	939	805	705	626	564	512	470	434	403	
45	153,549	GPH	465	342	310	266	233	207	186	169	155	143	133	
		LPH	1761	1409	1174	1006	881	783	705	640	587	542	503	
54	184,259	GPH	558	447	372	319	279	248	223	203	186	172	160	
		LPH	2114	1691	1409	1208	1057	939	845	769	705	650	604	



The new degree of comfort.



Recommended Specifications

Water heater(s) shall be model _____, manufactured by Rheem, having electrical input of _____ kW and a recovery rate of _____ GPH at a 100°F temperature rise. Water heater(s) shall have a storage capacity of 10 gallons. Water heater(s) shall have the UL seal of certification and be factory equipped with an CSA/ASME rated temperature and pressure relief valve. Tank(s) shall have a unique coating of high temperature porcelain enamel and furnished with magnesium anode rods rigidly supported. Water heater(s) shall meet or exceed the efficiency requirements of ASHRAE. Tank(s) shall have a working pressure rating of 150 psi, and shall be completely

assembled. Water heater(s) shall be approve-listed and constructed in accordance with UL Sanitation (NSF5). Water heater(s) shall be equipped with "screw-in" type elements. Water heater(s) shall be constructed with a SYSTEM SENTINEL element diagnostic panel utilizing light emitting diodes. Each LED will correspond to the number and location of the heating elements and monitor their on-off function. Water heater(s) shall be provided with internal power circuit fusing, control circuit fusing, magnetic contactors, 120 volt control circuit transformer and immersion thermostat(s) with manual reset high limit control. 1-1/4" inlet and outlet water connections shall be provided. Water heater(s) shall be covered by a three year limited warranty against tank leaks.

In keeping with its policy of continuous progress and product improvement, Rheem reserves the right to make changes without notice.

Rheem Water Heating • 1115 Northmeadow Parkway, Suite 100
Roswell, Georgia 30076 • www.rheem.com

Rheem Canada Ltd./Ltée • 125 Edgeware Road, Unit 1
Brampton, Ontario L6Y 0P5 • www.rheem.ca

