



Versus™ Line Gas Furnaces



W921W

92% A.F.U.E.†

Heating Stages: Single Stage

Motor Type: Constant CFM

Input Rates: 40 to 115 kBTU [11.7 to 33.7 kW]

Configuration Options: 4-Way Multi-Position



† A.F.U.E. (Annual Fuel Utilization Efficiency) calculated in accordance with Department of Energy test procedures.

1Proper sizing and installation of equipment is critical to achieve optimal performance. Split system air conditioners and heat pumps must be matched with appropriate coil components to meet ENERGY STAR®. Ask your Contractor for details or visit www.energystar.gov.

Table of Contents

Features and Benefits	3
Model Number Identification	4
Physical Data and Specifications	5
Dimensional Data	6
Blower Performance Data	7
Accessories	8
Limited Warranty	9

Features and Benefits

- **Energy Efficiency:** US South ENERGY STAR® certified, featuring 92% AFUE across all model sizes
- **Diagnostics:** With the BluArch® Contractor App & Bluetooth®¹ technology makes monitoring, troubleshooting and repairing the product easier than ever before
- **Dip Switch Free Installation Commissioning via Bluetooth® Technology:** Seamless final install step without DIP switch configuration using the BluArch® Contractor App
- **Ignition System:** Proven Direct Spark Ignition (DSI) for reliability and longevity
- **Water Management System:** Patented block drain sensor that automatically shuts off the furnace when the drain is blocked, and also alerts the contractor via diagnostic code
- **Constant CFM Motor:** Truly variable speed technology allows for ultimate humidity control, quieter sound levels and year-round energy savings

¹The Bluetooth® word mark and logos are registered trademarks owned by Bluetooth SIG, Inc. and any use of such marks is under license. Other trademarks and trade names are those of their respective owners.

Gas Furnaces

<u>W</u>	<u>92</u>	<u>1</u>	<u>W</u>	<u>040</u>	<u>3</u>	<u>A</u>	<u>17</u>	<u>M4</u>	<u>S</u>	<u>B</u>	<u>A</u>	<u>S</u>
Brand	Furnace Efficiency	Stages of Heating	Motor Type	Heating Input	AC Max. Capacity	Major Series	Width	Position	NOx	Controls	Minor Series	Option Code
W - WeatherKing	92 - 92% AFUE	1 - Single Stage	W - ECM Variable Speed	040 - 40K BTUH [11.7 kW] 060 - 60K BTUH [17.6 kW] 070 - 70K BTUH [20.5 kW] 085 - 85K BTUH [24.9 kW] 100 - 100K BTUH [29.3 kW] 115 - 115K BTUH [33.7 kW]	3 - 3 ton drive 5 - 5 ton drive	A - 1st Design Series	17 - 17.5" Width 21 - 21" Width 24 - 24.5" Width	M4 - Multi-4 Way	S - Standard	B - Communicating, Bluetooth®	A - 1st Series	S - Standard Grade

[] Designates Metric Conversions

AVAILABLE MODELS
W921W0403A17M4SBAS
W921W0603A17M4SBAS
W921W0703A17M4SBAS
W921W0705A21M4SBAS
W921W0855A21M4SBAS
W921W1005A21M4SBAS
W921W1155A24M4SBAS

STANDARD EQUIPMENT
100% safety lock out
29-4C stainless steel secondary heat exchanger design
Adjustable cool fan off delay
Aluminized steel primary heat exchanger design
Blocked Drain Sensor
Blower compartment door safety switch
Bluetooth® setup and diagnostics
Completely assembled and wired
Direct drive motor
Thermostat connections
Electronic on/off blower time control
Fully insulated heat exchanger cabinet
Humidistat terminal connection
Induced draft motor
Limit controls
Low speed continuous fan option
Manual shut-off valve
Marked condensate hoses
One hour automatic retry
Power and self test diagnostics
Pressure switch
PWM Controlled constant torque electrically commutated blower motor
Redundant main gas control
Single stage heating thermostat connection
Two plus stage cooling thermostat connection ¹

¹When connected to three-speed or modulating AC/HP product

WARNING
 THIS FURNACE IS NOT APPROVED
 OR RECOMMENDED
 FOR USE IN MOBILE HOMES

Physical Data and Specifications—U.S. Models

MODEL NUMBERS	W921W0403 A17M4SBAS	W921W0603 A17M4SBAS	W921W0703 A17M4SBAS	W921W0705 A21M4SBAS	W921W0855 A21M4SBAS	W921W1005 A21M4SBAS	W921W1155 A24M4SBAS
HIGH FIRE INPUT BTU/HR [kW] ①	42,000 [12.30]	56,000 [16.41]	70,000 [20.51]	70,000 [20.51]	84,000 [24.61]	98,000 [28.72]	112,000 [32.82]
HEATING CAPACITY BTU/HR [kW]	39,900 [11.69]	53,200 [15.59]	66,500 [19.49]	66,500 [19.49]	79,800 [23.39]	93,100 [27.28]	106,400 [31.18]
HIGH ALTITUDE OUTPUT 10% DERATE [kW] ②	35,910 [10.52]	47,880 [14.03]	59,850 [17.54]	59,850 [17.54]	71,820 [21.05]	83,790 [24.56]	95,760 [28.06]
BLOWER (D x W) [mm]	11 x 7 [279 x 178]	11 x 8 [279 x 203]	11 x 8 [279 x 203]	11 x 10 [279 x 254]	11 x 10 [279 x 254]	11 x 10 [279 x 254]	11 x 11 [279 x 279]
MOTOR H.P. [W]—TYPE	1/2 [373] VS-CT(ECM)	1/2 [373] VS-CT(ECM)	1/2 [373] VS-CT(ECM)	1 [746] VS-CT(ECM)	1 [746] VS-CT(ECM)	1 [746] VS-CT(ECM)	1 [746] VS-CT(ECM)
MIN. CIRCUIT AMPACITY	11.00	10.00	10.00	17.00	16.00	17.00	17.00
MIN. OVERLOAD PROTECTION DEVICE	15.00	15.00	15.00	20.00	20.00	20.00	20.00
MAX. OVERLOAD PROTECTION DEVICE	15.00	15.00	15.00	25.00	25.00	25.00	25.00
Motor Full Load Amps	6.3	6.1	6.1	12.4	12.4	12.4	12.4
MAXIMUM EXT. STATIC PRESSURE (IN. W.C.) [kPa]	1.0 [0.25]	1.0 [0.25]	1.0 [0.25]	1.0 [0.25]	1.0 [0.25]	1.0 [0.25]	1.0 [0.25]
HEATING CFM [L/s]	990 [468]	1100 [520]	1200 [566]	1375 [649]	1735 [819]	1440 [680]	1650 [779]
MAX Cooling CFM [L/s]	1240 [585]	1240 [585]	1240 [585]	1980 [934]	1980 [934]	1980 [934]	1980 [934]
MIN Cooling CFM [L/s]	300 [142]	300 [142]	300 [142]	500 [236]	500 [236]	500 [236]	500 [236]
Fan CFM [L/s]	600 [283]	600 [283]	600 [283]	1000 [472]	1000 [472]	1000 [472]	1000 [472]
TEMPERATURE RISE-HIGH FIRE RANGE IN DEGREES °F [°C]	20 - 50 [11 - 28]	30 - 60 [17 - 33]	40 - 70 [22 - 39]	30 - 60 [17 - 33]	40 - 70 [23 - 39]	40 - 70 [22 - 39]	45 - 75 [25 - 42]
APPROX. SHIPPING WEIGHT (LBS.) [kg]	123 [56]	128 [58]	133.5 [61]	146.5 [66]	150 [68]	155 [70]	190 [86.2]
AFUE ③	92.00%	92.00%	92.00%	92.00%	92.00%	92.00%	92.00%

NOTES: All models are 115V, 60HZ, 1 phase Gas connection size for all models is 1/2" [13 mm] N.P.T.

① Installation instructions for high altitude derate.

② Canadian installations only.

③ In accordance with D.O.E. test procedures.

NOTE: Standard model complies with California low nox requirements up to 40ng/J.

This furnace does not meet air district requirements of 14 ng/J NOx emissions limit, and thus is subject to a mitigation fee of up to \$450.

This furnace is to be installed for propane firing only in air districts requiring 14 ng/J NOx emission limits. Operating in natural gas mode is in violation of these Rules.

[] Designates Metric Conversions

Multi-Position Application

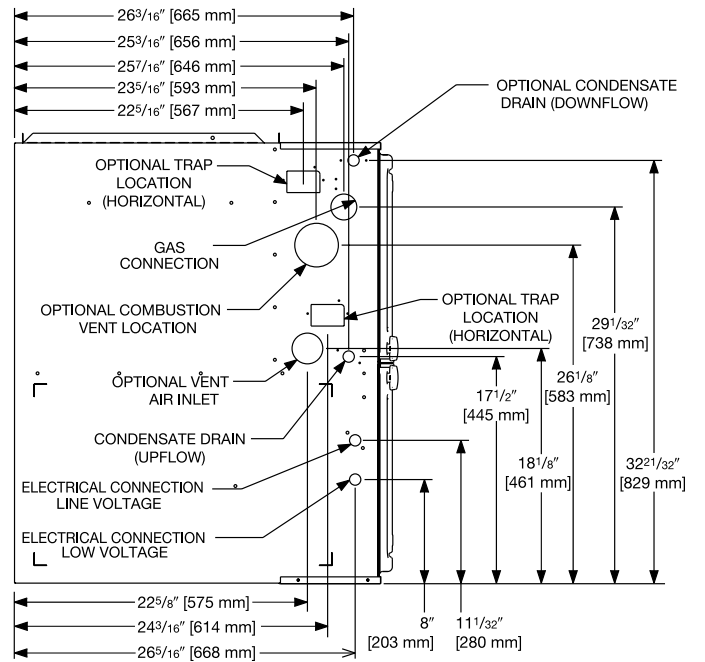
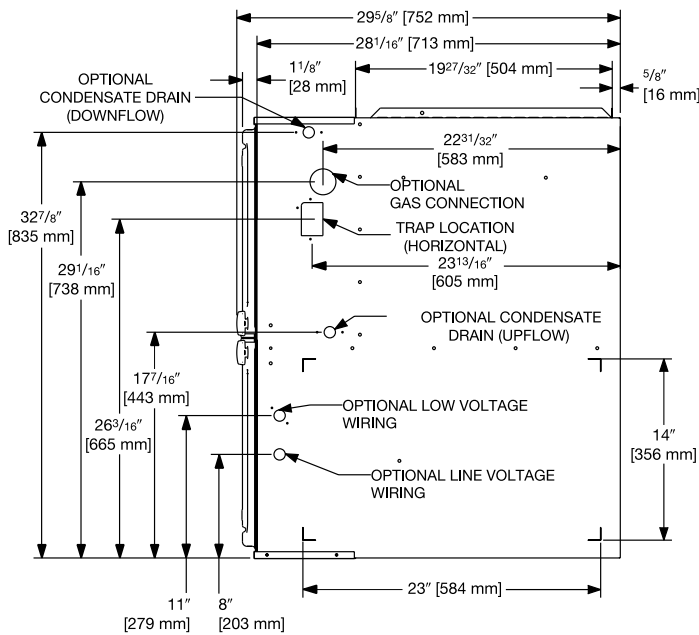
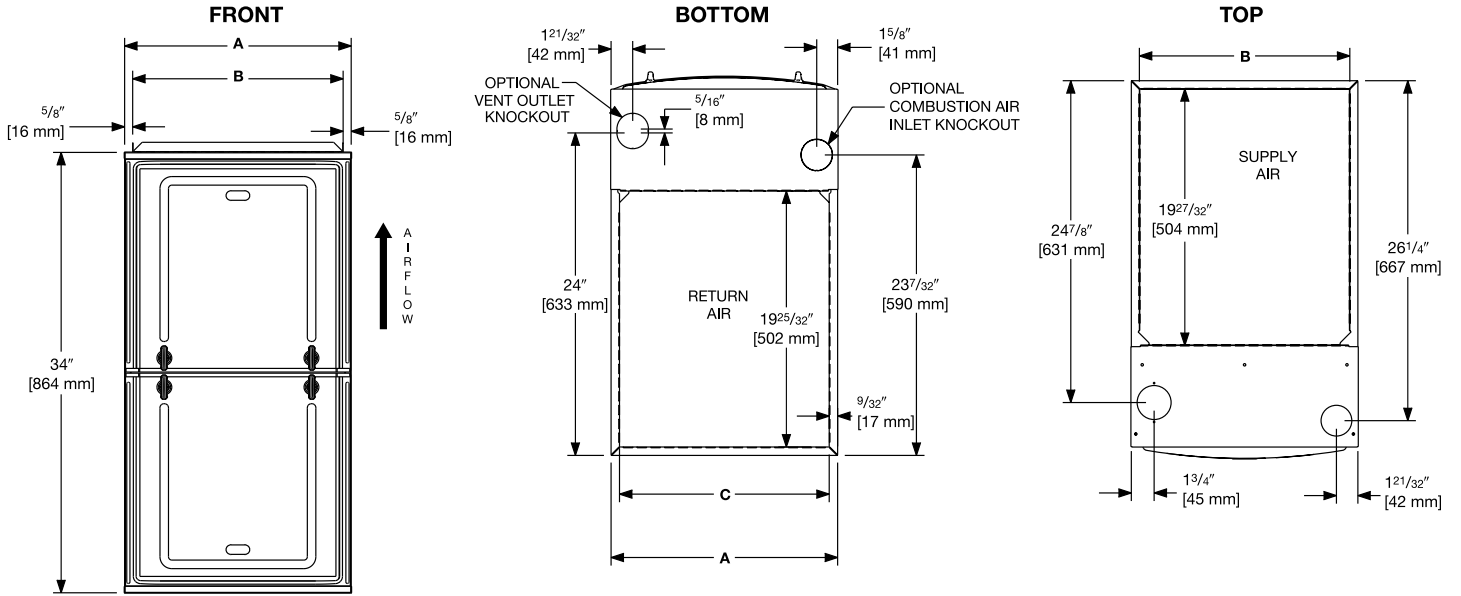

RIGHT SIDE

LEFT SIDE

Unit Dimensions (Clearance To Combustibles)

MODEL W921W	LEFT SIDE	MINIMUM CLEARANCE (IN.) [mm]					SHIP WGTs.	FLANGE DIMENSIONS		
		RIGHT SIDE	BACK	TOP	FRONT	VENT		A	B	C
040	0	0	0	1 [25]	2 [51]	0	123.5 [56]	17 1/2 [445]	16 17/64 [413]	16 13/64 [412]
060	0	0	0	1 [25]	2 [51]	0	128 [58]	17 1/2 [445]	16 17/64 [413]	16 13/64 [412]
070	0	0	0	1 [25]	2 [51]	0	132 [60]	17 1/2 [445]	16 17/64 [413]	16 13/64 [412]
070 (wide)	0	0	0	1 [25]	2 [51]	0	147.5 [67]	21 [533]	19 49/64 [502]	19 45/64 [500]
085	0	0	0	1 [25]	2 [51]	0	147.5 [67]	21 [533]	19 49/64 [502]	19 45/64 [500]
100	0	0	0	1 [25]	2 [51]	0	152 [69]	21 [533]	19 49/64 [502]	19 45/64 [500]
115	0	0	0	1 [25]	2 [51]	0	165 [75]	24 1/2 [662]	23 17/64 [591]	23 13/64 [589]

*A service clearance of at least 24" is recommended in front of all furnaces
 Supply and return depicted as upflow configuration.
 Flange configuration will vary depending on installation orientation.

[] Designates Metric Conversions

Blower Performance Data

TARGET GAS HEATING AIRFLOWS							
	W921W0403 A17M4SBAS	W921W0603 A17M4SBAS	W921W0703 A17M4SBAS	W921W0705 A21M4SBAS	W921W0855 A21M4SBAS	W921W1005 A21M4SBAS	W921W1155 A24M4SBAS
Furnace Hi Heat CFM A (factory)	990 [468]	1100 [520]	1200 [566]	1375 [649]	1735 [819]	1440 [680]	1650 [779]
Furnace Hi Heat CFM B (side return)	990 [468]	1188 [561]	1296 [612]	1550 [732]	1874 [884]	1691 [798]	1800 [850]
Furnace Hi Heat CFM C (Approx. +7°F)	891 [421]	990 [468]	1080 [510]	1238 [584]	1562 [737]	1296 [612]	1485 [701]
Furnace Hi Heat CFM D (Approx. +12°F)	822 [388]	913 [431]	996 [470]	1141 [539]	1440 [680]	1195 [564]	1370 [647]

[] Designates Metric Conversions

Vent Termination Kits:

RXGY-E02: Vertical/Horizontal Concentric Vent Termination Kit
2" Pipe (US Only)

RXGY-E02A: Vertical/Horizontal Concentric Vent Termination Kit
2" Pipe (US & Canadian)

RXGY-E03: Vertical/Horizontal Concentric Vent Termination Kit
3" Pipe (US Only)

RXGY-E03A: Vertical/Horizontal Concentric Vent Termination Kit
3" Pipe (US & Canadian)

RXGY-G02: Direct Vent Furnace Side Wall Vent 2" or 3" (US Only)

RXGY-D05: Combustion Air Drain Kit 2"

RXGY-D06: Combustion Air Drain Kit 3"

NEUTRALIZER KIT: RXGY-A01
(Replacement Cartridge 54-22120-01)

EXTERNAL BOTTOM FILTER (UPFLOW/HORIZONTAL) RACK:
RXGF-CB

EXTERNAL SIDE (UPFLOW) FILTER RACK: RXGF-CD

EXTERNAL (DOWNFLOW) FILTER RACK: RXGF-CC

For High Altitudes:

NOTE: For Canadian installations only, an optional derate (manifold gas pressure reduction) method may be used to adjust the furnace for altitude. See Installation Instructions for more information. This optional method may **NOT** be used for U.S. installations. See installation instructions as appropriate orifice change is required.

L.P. CONVERSION KIT: RXGJ-FP38

CONDENSATE PUMP KIT: PROSTOCK & 1PCB151TUL

DOWNFLOW/HORIZONTAL CONVERSION KIT: RXGY-CK

**DOWNFLOW/HORIZONTAL LEFT ZERO CLEARANCE
CONVERSION KIT:** RXGY-ZK

COMBUSTIBLE FLOOR BASE: RXGC-B17
RXGC-B21
RXGC-B24

FILTER RACK FILTER SIZES* INCHES [mm]			
MODEL	RXGF-CB (UPFLOW/ HORIZONTAL)	RXGF-CD (UPFLOW)	RXGF-CC (DOWNFLOW)
W921W(-)040	15 ³ / ₄ x 25 [400 x 635]	15 ³ / ₄ x 25 [400 x 635]	14 x 20 [356 x 508]
W921W(-)060	15 ³ / ₄ x 25 [400 x 635]	15 ³ / ₄ x 25 [400 x 635]	14 x 20 [356 x 508]
W921W(-)070	15 ³ / ₄ x 25 [400 x 635]	15 ³ / ₄ x 25 [400 x 635]	14 x 20 [356 x 508]
W921W(-)070 (wide)	19 ¹ / ₄ x 25 [489 x 635]	15 ³ / ₄ x 25 [400 x 635]	12 x 20 [305 x 508]
W921W(-)085	19 ¹ / ₄ x 25 [489 x 635]	15 ³ / ₄ x 25 [400 x 635]	14 x 20 [356 x 508]
W921W(-)100	19 ¹ / ₄ x 25 [489 x 635]	15 ³ / ₄ x 25 [400 x 635]	14 x 20 [356 x 508]
W921W(-)115	22 ³ / ₄ x 25 [578 x 635]	15 ³ / ₄ x 25 [400 x 635]	14 x 20 [356 x 508]

[] Designates Metric Conversions

Indoor Coil Casings

MODEL NUMBER
RXBC-D17A1
RXBC-D21A1
RXBC-D21B1
RXBC-D24A1



GENERAL TERMS OF LIMITED WARRANTY*

WeatherKing will furnish a replacement for any part of this product which fails in normal use and service within the applicable period stated, in accordance with the terms of the limited warranty.

***For complete details of the Limited and Conditional Warranties, including applicable terms and conditions, contact your local contractor or the Manufacturer for a copy of the product warranty certificate.**

Conditional Parts
(Registration Required) Ten (10) Years
Heat Exchanger Fifteen (15) Years

Before proceeding with installation, refer to installation instructions packaged with each model, as well as complying with all Federal, State, Provincial, and Local codes, regulations, and practices.

© 2025 Rheem Manufacturing Company. WeatherKing trademarks owned by Rheem Manufacturing Company.

"In keeping with its policy of continuous progress and product improvement, WeatherKing reserves the right to make changes without notice."

5600 Old Greenwood Road
Fort Smith, Arkansas 72908 • www.weatherking.com

125 Edgeware Road, Unit 1
Brampton, Ontario • L6Y 0P5 • weatherking.ca