



PROJECT NAME \_\_\_\_\_  
 LOCATION \_\_\_\_\_  
 ARCHITECT \_\_\_\_\_  
 ENGINEER \_\_\_\_\_  
 CONTRACTOR \_\_\_\_\_  
 SUBMITTED BY \_\_\_\_\_ DATE \_\_\_\_\_

**UNIT SUMMARY**

Quantity						
Unit Designation						
Model No.						
Total Cooling						
Sensible Cooling						
Air Ent. Evaporator						
Air Lvg. Evaporator						
Heating Input						
Heating Output						
CFM/ESP						
EER/SEER						
Electrical						
Minimum Ampacity						
Min.-Max. Breaker						
Net Unit Weight						
Accessory						
Catalog Form Number						

**ACCESSORIES:**

**NOTES:**

# Endeavor® Line (-)P15AZ iC Heat Pumps

## Heating Efficiencies up to: 8.1 HSPF2

## Cooling Efficiencies up to: 16 SEER2/11.7 EER2

## Nominal Sizes: 1.5 to 5 Ton [5.0 to 16.3 kW]

JOB NAME \_\_\_\_\_ LOCATION \_\_\_\_\_

CONTRACTOR \_\_\_\_\_ ORDER NO. \_\_\_\_\_

ENGINEER \_\_\_\_\_ UNIT MODEL NO. \_\_\_\_\_

SUBMITTED FOR  APPROVAL  RECORD COIL MODEL NO. \_\_\_\_\_

DATE \_\_\_\_\_ AIR HANDLER MODEL NO. \_\_\_\_\_

### UNIT DATA

#### COOLING PERFORMANCE

EFFICIENCY ..... SEER

TOTAL CAPACITY\* ..... MBH [kW]

SENSIBLE CAPACITY\* ..... MBH [kW]

OUTDOOR DESIGN TEMP..... °F [°C] DB

TEMP. OF AIR ENTERING  
EVAPORATOR COIL ..... °F [°C] DB

..... °F [°C] WB

POWER INPUT REQUIREMENT ..... kW  
(\*uses blower motor heat)

#### HEATING PERFORMANCE

EFFICIENCY ..... HSPF

TOTAL CAPACITY\* ..... MBH [kW]

OUTDOOR DESIGN TEMP..... °F [°C] DB

TEMP. OF AIR ENTERING  
EVAPORATOR COIL ..... °F [°C] DB

#### SUPPLY AIR BLOWER PERFORMANCE

TOTAL AIR SUPPLY..... CFM [L/s]

TOTAL RESISTANCE EXTERNAL  
TO UNIT ..... IWG

BLOWER SPEED..... RPM

POWER OUTPUT REQUIREMENT ..... BHP

MOTOR RATING ..... HP [W]

POWER INPUT REQUIREMENT ..... kW

#### ELECTRICAL DATA

POWER SUPPLY ..... Hz

TOTAL UNIT AMPACITY..... AMPS

MINIMUM WIRE SIZE ..... AWG

MAXIMUM OVERCURRENT DEVICE  
FUSES/HACR BREAKER ..... AMPS

#### CLEARANCES

ACCESS SIDE 24" [609.6 mm]

AIR INLETS 12" [304.8 mm]

ABOVE UNIT 60" [1524 mm]

### FEATURES

- **Fully Louvered Steel Cabinet:** Features durable construction to add protection from yard hazards, weather corrosion
- **Two-Stage Scroll Compressor:** Features two speeds (high and low) of cooling and heating, providing more precise temperature control, lower humidity and greater efficiency when compared to single stage compressors
- **7 mm Condenser Copper Coil<sup>1</sup>:** Requires less refrigerant allowing for a smaller and lighter footprint while enhancing reliability
- **Inverted Reversing Valve:** Allows for faster heat transfer with gravity assist shifting and reduced joint stress for increased reliability
- **Easily Accessible Control Box:** Ease of installation and serviceability

### ACCESSORIES/OPTIONS

- Compressor Crankcase Heater.....
- Low Ambient Control (Model No. RXAD-A08).....
- Compressor Sound Cover.....
- Compressor Hard Start Kit.....
- Low Pressure Control.....
- High Pressure Control.....
- Classic Top Cap w/Label (91-101123-21).....
- Liquid Line Solenoid (24 VAC, 50/60 Hz).....
- Liquid Line Solenoid (120/240 VAC, 50/60 Hz).....

<sup>1</sup>Does not apply to the 5 Ton Model



9001:2015



*\*Proper sizing and installation of equipment is critical to achieve optimal performance. Split system air conditioners and heat pumps must be matched with appropriate coil components to meet Energy Star. Ask your Contractor for details or visit [www.energystar.gov](http://www.energystar.gov).*

**(-)P15AZ**

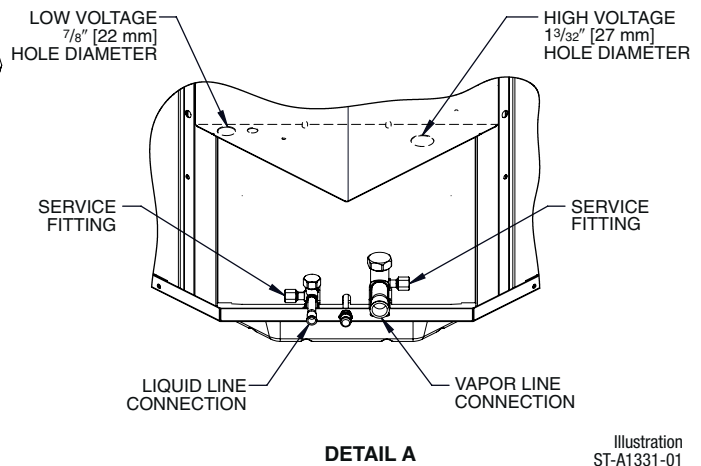
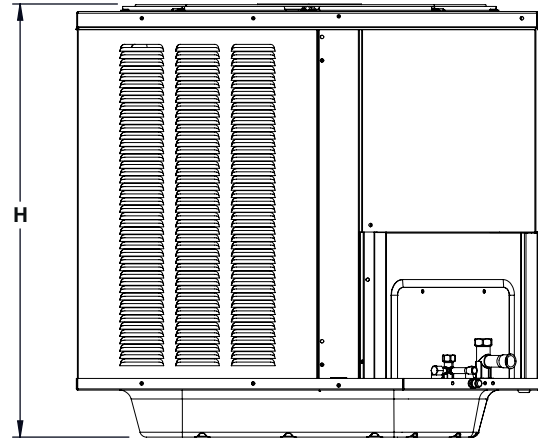
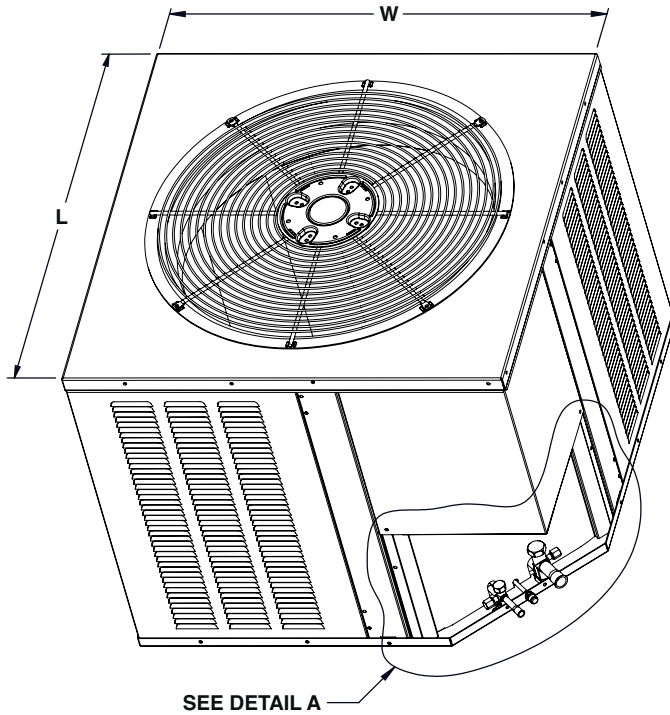

Illustration  
ST-A1331-01

**NOTE:** Illustrations show the deep drawn basepan.

[ ] Designates Metric Conversions

**Unit Dimensions**

MODEL NO.	OPERATING						SHIPPING					
	H (Height)		L (Length)		W (Width)		H (Height)		L (Length)		W (Width)	
	INCHES	mm	INCHES	mm	INCHES	mm	INCHES	mm	INCHES	mm	INCHES	mm
(-)P15AZ18AJ2NA	25.170	639.32	29.543	750.39	29.543	750.39	27.063	687.39	32.625	828.68	32.625	828.68
(-)P15AZ24AJ2NA	25.170	639.32	29.543	750.39	29.543	750.39	27.063	687.39	32.625	828.68	32.625	828.68
(-)P15AZ30AJ2NA	35.170	893.32	33.655	854.84	33.655	854.84	37.063	941.39	36.625	930.28	36.625	930.28
(-)P15AZ36AJ2NA	39.170	994.92	33.655	854.84	33.655	854.84	41.063	1042.99	36.625	930.28	36.625	930.28
(-)P15AZ42AJ2NA	39.170	994.92	33.655	854.84	33.655	854.84	41.063	1042.99	36.625	930.28	36.625	930.28
(-)P15AZ48AJ2NA	39.170	994.92	33.655	854.84	33.655	854.84	41.063	1042.99	36.625	930.28	36.625	930.28
(-)P15AZ60AJ2NA	51.170	1299.72	35.543	902.79	35.543	902.79	53.063	1347.79	38.625	981.08	38.625	981.08

**Before proceeding with installation, refer to installation instructions packaged with each model, as well as complying with all Federal, State, Provincial, and Local codes, regulations, and practices.**

Rheem Sales Company, Inc.  
5600 Old Greenwood Road  
Fort Smith, Arkansas 72908

© 2023 Rheem Manufacturing Company. Rheem and Ruud trademarks owned by Rheem Manufacturing Company.

*"In keeping with its policy of continuous progress and product improvement, Rheem reserves the right to make changes without notice."*