



The new degree of comfort.™

Rheem *Commercial Value Series* Package Gas Electric Unit



RKKN-B Standard Efficiency Series

RKKN-C Standard Efficiency Series

With ClearControl™ (DDC)

Nominal Sizes 6 Ton [21.1 kW]

ASHRAE 90.1-2010 Compliant Models



"Proper sizing and installation of equipment is critical to achieve optimal performance. Ask your Contractor for details or visit www.energystar.gov."

TABLE OF CONTENTS

Unit Features & Benefits	3-5
Model Number Identification	6
Selection Procedure	7
Options	8-9
General Data.....	10-12
General Data Notes	13
Gross Systems Performance Data	14
Indoor Airflow Performance.....	15
Electrical Data	16
Dimensional Data	17-19
Accessories	20-30
Mechanical Specifications	31-36
Limited Warranty	37



STANDARD FEATURES INCLUDE:

- R-410A HFC refrigerant.
- Complete factory charged, wired and run tested.
- Scroll compressors with internal line break overload and high-pressure protection.
- Two-stage compressor on all models.
- Convertible airflow.
- TXV refrigerant metering system.
- High Pressure and Low Pressure/Loss of charge protection standard on all models.
- Solid Core liquid line filter drier.
- Single slab evaporator coil facilitate easy cleaning for maintained high efficiencies.
- Cooling operation up to 125 degree F ambient.
- Easily removable filter, blower, gas heat, and compressor/control access panels permits prompt service.
- One piece top cover and one piece base pan with drawn supply and return opening for superior water management.
- Externally mounted refrigerant gauge ports for easy service diagnostics.
- Easy to install plug-in; slip in, 100% fully modulating economizer.
- 82% of steady state efficiency
- Forkable base rails for easy handling and lifting.
- Single point electrical and gas connections.
- High performance belt drive motor with variable pitch pulleys and quick adjust belt system.
- Permanently lubricated evaporator, condenser and gas heat inducer motors.
- Condenser motor is internally protected, totally enclosed with shaft down design.
- 2 inch filter standard with slide out design.
- Single stage gas valve, direct spark ignition, and induced draft for efficiency and reliability.
- Tubular heat exchange for long life and induced draft for efficiency and reliability.
- Solid state furnace control with on board diagnostics.
- Colored and labeled wiring.
- Molded compressor plug.
- Micro Channel evaporator and condenser deliver superior performance with less refrigerant charge and less weight than conventional copper tube/aluminum fin coils In addition the aluminum design has superior formicary corrosion protection and less potential for leaks due to elimination of tube rubbing potential. Its easier to clean and has a more robust surface.
- All 208/230V and 460V models are shipped with mating plugs for a field installed VFD kit to provide 2-stage indoor airflow.
- RKKN-C models equipped with factory installed ClearControl™, Direct Digital Control (DDC), and sensors which can connect to LonWorks™ or BACnet® building automation systems for remote monitoring and control.

CLEARCONTROL™ (RKKN-C MODELS)

As part of the ClearControl™ system which allows for real time monitoring and communication, the RKKN-C Package Gas/Electric has a Rooftop Unit Controller (RTU-C) referred to as the ClearControl™ factory mounted and wired in the control panel. The RTU-C ClearControl™ is a solid-state microprocessor-based control board that provides flexible control and extensive diagnostics for all unit functions. The RTU-C through proportional/integral control algorithms perform specific unit functions that govern unit operation in response to: zone conditions, system temperatures, system pressures, ambient conditions and electrical inputs. The RTU-C features a 16 x 2 character LCD display and a five-button keypad for local configuration and direct diagnosis of the system. New features include a clogged filter switch (CFS), fan proving switch (FPS), return air temperature sensor (RAT), discharge air temperature sensor (DAT) and outdoor air temperature sensor (OAT). Freeze sensors (FS) are used in place of freezestats to allow measurement of refrigerant suction line temperatures. The RKKN-C Package Gas/Electric with the RTU-C is specifically designed to be applied in four distinct applications:

The RKKN-C is compatible with a third party building management system that supports the BACnet Application Specific Controller device profile, with the use of a field installed BACnet Communication Module. The BACnet Communication Module plugs onto the unit RTU-C controller and allows communication between the RTU-C and the BACnet MSTP network. A zone sensor, a BACnet network zone sensor, a BACnet thermostat or DDC controller may be used to send the zone temperature or thermostat demands to the RTU-C. The BACnet Communication Module is compatible with MSTP EIA-485 daisy chain networks communicating at 38.4 bps. It is compatible with twisted pair, shielded cables.

The RKKN-C is compatible with a third party building management system that supports the LonMark Space Comfort controller (SCC) functional profile or LonMark Discharge Air Controller (DAC) functional profile. This is accomplished with a

field installed LonMark communication module. The LonMark Communication Module plugs onto the RTU-C controller and allows communication between the RTU-C and a LonWorks Network. A zone sensor, a LonTalk network zone sensor, or a LonTalk thermostat or DDC controller may be used to send the zone temperature or thermostat demands to the RTU-C. The LonMark Communication Module utilizes an FTT-10A free topology transceiver communicating at 78.8 kbps. It is compatible with Echelon qualified twisted pair cable, Belden 8471 or NEMA Level 4 cables. The Module can communication up to 1640 ft. with no repeater. The LonWorks limit of 64 nodes per segment applies to this device.

The RKKN-C is compatible with a programmable 24 volt thermostat. Connections are made via conventional thermostat screw terminals. Extensive unit status and diagnostics are displayed on the LCD screen of the RTU-C.

The RKKN-C is compatible with a zone sensor and mechanical or solid state time clock connected to the RTU-C. Extensive unit status and diagnostics are displayed on the LCD screen of the RTU-C.

A factory or field installed Comfort Alert® module is available for power phase-monitoring protection and additional compressor diagnostics. The alarms can be displayed on the RTU-C display or connected to the "L-Terminal" of a thermostat for notification.

The damper minimum position, actual damper position, power exhaust on/off setpoint, mixed air temperature limit setpoint and Demand Controlled Ventilation (DCV) setpoint can be read and adjusted at the unit controller display or remotely through a network connection.

The Space CO₂ level, mixed air temperature, and Economizer Status (Free Cooling Available, Single or Dual Enthalpy) can be read at the unit controller display or remotely through a network connection. Economizer Faults will trigger a network Alarm and can be read at the unit controller display or remotely through a network connection.

RTU-C/ClearControl™

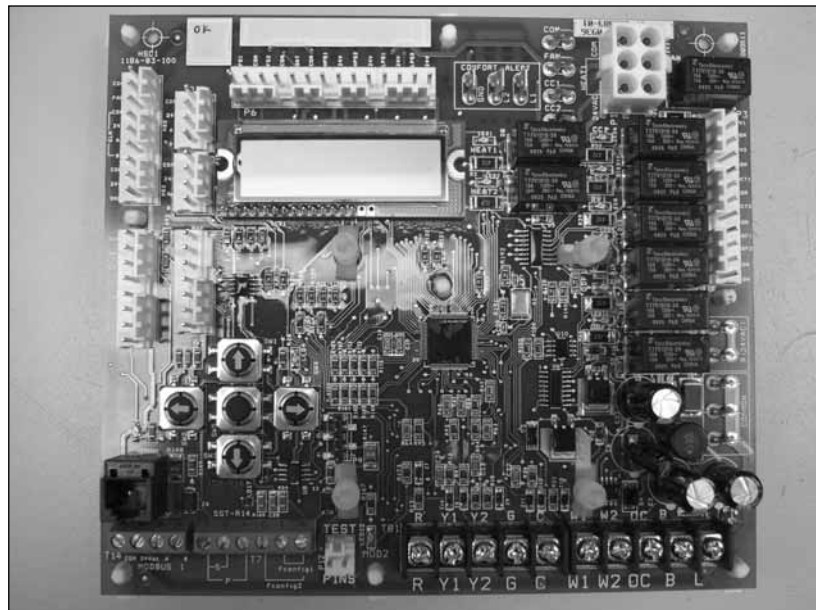



Evaporator Coil/Filter Access

- Return air filters, normally provided, are removed in this photo.



- Non-corrosive plastic condensate pan



Return Air Sensor

(RKKN-C Only)

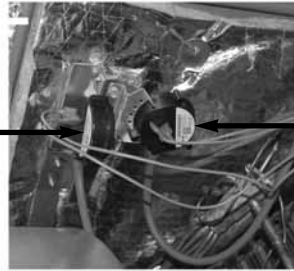

Fan Proving Switch

Clogged Filter Switch

Tubular Heat Exchanger

- Aluminized steel (viewed from supply air side panel.)
- Stainless steel available



Control Box Access



Outdoor Air Sensor (RKKN- Only)

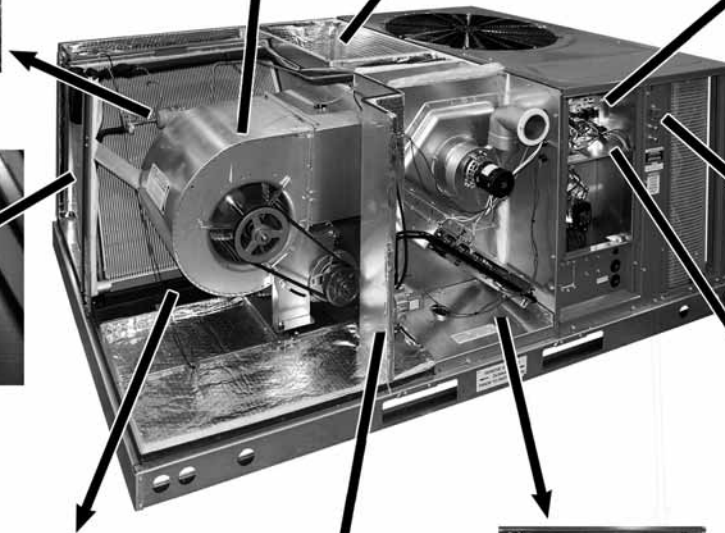

Blower Access



Discharge Air Sensor (RKKN-C Only)



Heating Compartment Access



Freeze Sensor (RKKN-C Only)

[] Designates Metric Conversions

R K K N - B 073 C L 10 E X X X

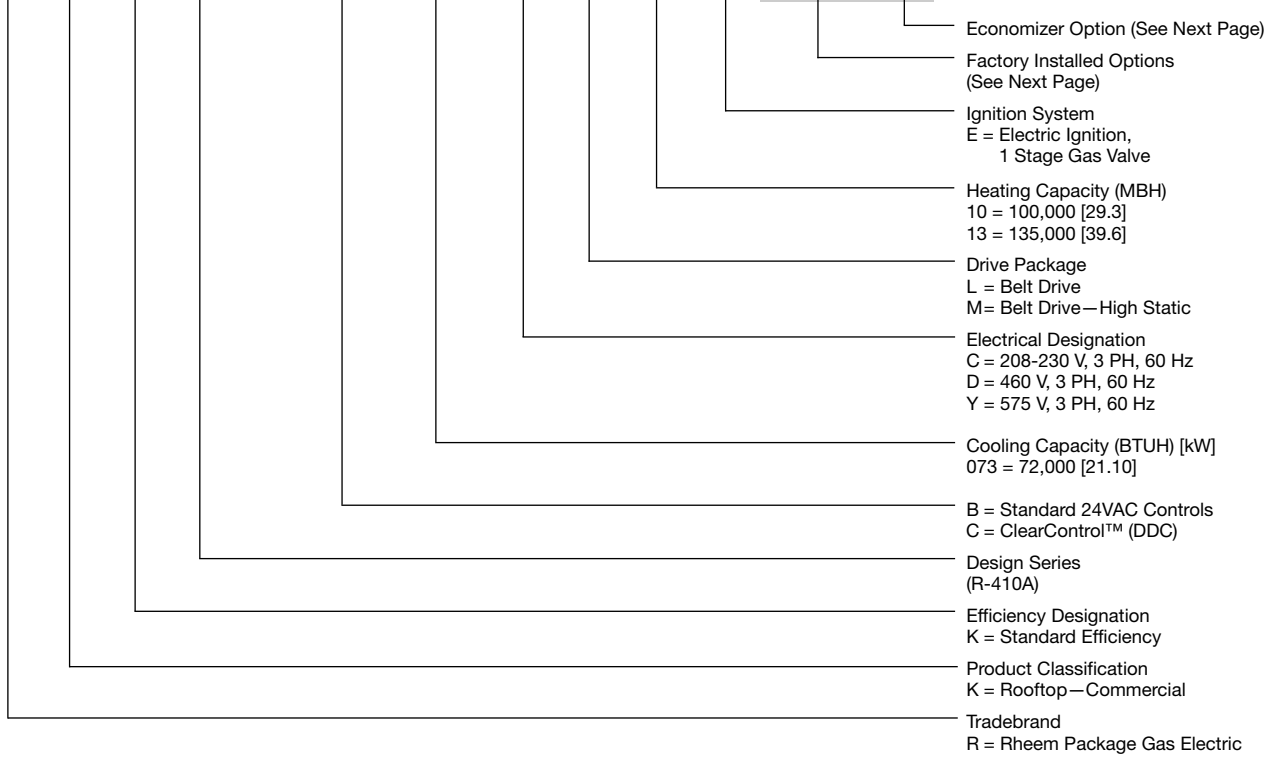

[] Designates Metric Conversions

1. Determine cooling and heating requirements at design conditions.

Example:

Power Supply	208/230-3 Phase
Total cooling capacity	61,000 BTUH [17.87 kW]
Sensible cooling capacity	44,000 BTUH [12.89 kW]
Heating capacity	96,000 BTUH [28.13 kW]
Condenser entering air	95°F [35°C]
Evaporator entering air	63°F [17°C] wb/76°F [24°C] db
Indoor air flow	2100 CFM [991 L/s]
External static pressure	1.1 in wg
Required efficiency	11.0 EER, 12.9 IEER

2. Select unit to meet cooling requirements.

Since total cooling is within the range of 6 ton [21.10 kW] unit and requires 11.0 EER/12.9 IEER efficiency level, enter cooling performance from the RKKN-B073 at 95°F [35°C] outdoor temperature, 63°F [17°C] wb entering indoor air, and 2100 CFM [991 L/s]:

Total capacity	65,000 BTUH [19.1 kW]
Sensible capacity	55,400 BTUH [16.2 kW]
Power input.....	5.4 kW

And also, at 76°F [24°C] db indoor entering air, and using the formula at the bottom of the table:

Sensible capacity	48,008 BTUH [14.07 kW]
-------------------------	------------------------

3. Select heating capacity of the unit.

In the general data tables, note that the heating capacity of the 6 ton [21.10 kW] model with the 135,000 input heater can deliver 109,400 BTUH [32.03 kW], which is suitable for this application.

4. Determine blower speed and power to meet the system requirements.

At the given external static pressure of 1.1 in wg, the belt model must be selected. Enter the belt drive blower performance data at 2100 CFM [991 L/s] and 1.1 in wg ESP:

RPM	1130
Watts	1060
Drive	M

5. Calculate indoor blower BTUH heat effect.

$$\text{BTUH} = \text{Watts} \times 3.413 = 3618$$

6. Calculate net cooling capacities.

$$\begin{aligned} \text{Net total cooling} &= 65,000 - 3618 = 61,382 \text{ BTUH [17.98 kW]} \\ \text{Net sensible cooling} &= 48,008 - 3618 = 44,390 \text{ BTUH [13.01 kW]} \end{aligned}$$

7. Select model

RKKN-B073CM13E

[] Designates Metric Conversions

FACTORY INSTALLED OPTION CODES FOR RKKN-B073 (6 TON) [21.1 kW]

Option Code	Hail Guard	Stainless Steel Heat Exchanger	Non-Powered Convenience Outlet/Unfused Service Disconnect	Low Ambient/ Freeze Stat	Hinged Doors
AA	NO OPTIONS				
AD	x				
AJ		x			
AH			x		
AP				x	
AV					x
BF	x		x		
BG	x	x			
BY	x			x	
JB		x	x		
JK	x				x
JM			x		x
JN		x			x
JP				x	x
CR	x	x		x	
KE	x		x		x
KF	x	x			x
KG	x			x	x
KM		x	x		x
KN			x	x	x
KQ		x		x	x
DN	x	x	x	x	
DU	x	x	x		x
DV	x		x	x	x
DX		x	x	x	x
EF	x	x	x	x	x

Economizer Codes

H = Economizer with Single Enthalpy

Example: RKKN-B073CL13E**XXX** (where **XX** is factory installed option)

Example: No Options

RKKN-B073CL13E

Example: No option with factory installed economizer

RKKN-B073CL13EAAF

Example: Options with stainless steel heat exchanger and no factory installed economizer RKKN-B073CL13EAJA

Example: Options same as above with factory installed economizer RKKN-B073CL13EAJF

ECONOMIZER SELECTION FOR RKKN-B073 (6 TON) [21.1 kW]

	No Economizer	Economizer No Smoke Detector	Economizer With Smoke Detector
A	x		
F		x	
G			x

"x" indicates factory installed option.

[] Designates Metric Conversions

FACTORY INSTALLED OPTION CODES FOR RKKN-C073 (6 TON) [21.1 kW]

Option Code	Hail Guard	Stainless Steel Heat Exchanger	Non-Powered Convenience Outlet/Unfused Service Disconnect	Low Ambient/Comfort Alert	Hinged Doors
AD	x				
AJ		x			
AH			x		
AR				x	
AV					x
BF	x		x		
BG	x	x			
JD	x			x	
JB		x	x		
JK	x				x
JM			x		x
JN		x			x
JQ				x	x
KE	x		x		x
KF	x	x			x
KH	x			x	x
KM		x	x		x
DP	x	x	x	x	
EG	x	x	x	x	x

Economizer Codes

H = Economizer with Single Enthalpy

Example: RKKN-C073CL13E**XX** (where **XX** is factory installed option)

Example: No Options

RKKN-C073CL13E

Example: No option with factory installed economizer

RKKN-C073CL13EAAH

Example: Options with stainless steel heat exchanger and no factory installed economizer RKKN-C073CL13EAJA

Example: Options same as above with factory installed economizer

RKKN-C073CL13EAJH

ECONOMIZER SELECTION FOR RKKN-C073 (6 TON) [21.1 kW]

	No Economizer	Single Enthalpy Economizer With Barometric Relief	Single Enthalpy Economizer With Barometric Relief and Smoke Detector
A	x		
H		x	
J			x

"x" indicates factory installed option.

[] Designates Metric Conversions

NOM. SIZES 6 TONS [21.1 kW]

Model RKKN- Series	(B,C)073CL10E	(B,C)073CM10E	(B,C)073CL13E	(B,C)073CM13E
Cooling Performance¹				CONTINUED →
Gross Cooling Capacity Btu [kW]	70,000 [20.51]	70,000 [20.51]	70,000 [20.51]	70,000 [20.51]
EER/SEER ²	11 / NA	11 / NA	11 / NA	11 / NA
Nominal CFM/AHRI Rated CFM [L/s]	2400 / 2100 [1133 / 991]	2400 / 2100 [1133 / 991]	2400 / 2100 [1133 / 991]	2400 / 2100 [1133 / 991]
AHRI Net Cooling Capacity Btu [kW]	68,000 [19.92]	68,000 [19.92]	68,000 [19.92]	68,000 [19.92]
Net Sensible Capacity Btu [kW]	46,000 [13.48]	46,000 [13.48]	46,000 [13.48]	46,000 [13.48]
Net Latent Capacity Btu [kW]	22,000 [6.45]	22,000 [6.45]	22,000 [6.45]	22,000 [6.45]
IEER ²	12.9	12.9	12.9	12.9
Net System Power kW	6.18	6.18	6.18	6.18
Heating Performance (Gas)³				
Heating Input Btu [kW]	100,000 [29.3]	100,000 [29.3]	135,000 [39.55]	135,000 [39.55]
Heating Output Btu [kW]	82,000 [24.03]	82,000 [24.03]	110,700 [32.43]	110,700 [32.43]
Temperature Rise Range °F [°C]	20-50 [11.1-27.8]	20-50 [11.1-27.8]	30-60 [16.7-33.3]	30-60 [16.7-33.3]
Steady State Efficiency (%)	82	82	82	82
No. Burners	5	5	6	6
No. Stages	1	1	1	1
Gas Connection Pipe Size in. [mm]	0.5 [12.7]	0.5 [12.7]	0.5 [12.7]	0.5 [12.7]
Compressor				
No./Type	1 / Two-Stage Scroll	1 / Two-Stage Scroll	1 / Two-Stage Scroll	1 / Two-Stage Scroll
Outdoor Sound Rating (dB)⁴				
	83	83	83	83
Outdoor Coil—Fin Type				
Tube Type	Louvered	Louvered	Louvered	Louvered
MicroChannel Depth in. [mm]	MicroChannel	MicroChannel	MicroChannel	MicroChannel
Face Area sq. ft. [sq. m]	0.71 [18]	0.71 [18]	0.71 [18]	0.71 [18]
Rows / FPI [FPcm]	16.4 [1.52]	16.4 [1.52]	16.4 [1.52]	16.4 [1.52]
	1 / 23 [9]	1 / 23 [9]	1 / 23 [9]	1 / 23 [9]
Indoor Coil—Fin Type				
Tube Type	Louvered	Louvered	Louvered	Louvered
MicroChannel Depth in. [mm]	MicroChannel	MicroChannel	MicroChannel	MicroChannel
Face Area sq. ft. [sq. m]	1.26 [32]	1.26 [32]	1.26 [32]	1.26 [32]
Rows / FPI [FPcm]	5.95 [0.55]	5.95 [0.55]	5.95 [0.55]	5.95 [0.55]
Refrigerant Control	1 / 22 [9]	1 / 22 [9]	1 / 20 [8]	1 / 22 [9]
Drain Connection No./Size in. [mm]	TX Valve	TX Valve	TX Valve	TX Valve
	1 / 0.75 [19.05]	1 / 0.75 [19.05]	1 / 0.75 [19.05]	1 / 0.75 [19.05]
Outdoor Fan—Type				
No. Used/Diameter in. [mm]	Propeller	Propeller	Propeller	Propeller
Drive Type/No. Speeds	1 / 24 [609.6]	1 / 24 [609.6]	1 / 24 [609.6]	1 / 24 [609.6]
CFM [L/s]	Direct / 1	Direct / 1	Direct / 1	Direct / 1
No. Motors/HP	4200 [1982]	4200 [1982]	4200 [1982]	4200 [1982]
Motor RPM	1 / 0.5	1 / 0.5	1 / 0.5	1 / 0.5
	1075	1075	1075	1075
Indoor Fan—Type				
No. Used/Diameter in. [mm]	FC Centrifugal	FC Centrifugal	FC Centrifugal	FC Centrifugal
Drive Type	1 / 11x10 [279x254]	1 / 11x10 [279x254]	1 / 11x10 [279x254]	1 / 11x10 [279x254]
No. Speeds	Belt (Adjustable)	Belt (Adjustable)	Belt (Adjustable)	Belt (Adjustable)
No. Motors	Single	Single	Single	Single
Motor HP	1	1	1	1
Motor RPM	2	2	2	2
Motor Frame Size	1725	1725	1725	1725
	56	56	56	56
Filter—Type				
Furnished	Disposable	Disposable	Disposable	Disposable
(NO.) Size Recommended in. [mm x mm x mm]	Yes	Yes	Yes	Yes
	(4)2x16x16 [51x406x406]	(4)2x16x16 [51x406x406]	(4)2x16x16 [51x406x406]	(4)2x16x16 [51x406x406]
Refrigerant Charge Oz. [g]				
	67 [1899]	67 [1899]	67 [1899]	67 [1899]
Weights				
Net Weight lbs. [kg]	615 [279]	617 [280]	620 [281]	622 [282]
Ship Weight lbs. [kg]	648 [294]	650 [295]	653 [296]	655 [297]

See Page 13 for Notes.

[] Designates Metric Conversions

NOM. SIZES 6 TONS [21.1 kW]

Model RKKN- Series	(B,C)073DL10E	(B,C)073DM10E	(B,C)073DL13E	(B,C)073DM13E
Cooling Performance¹				CONTINUED →
Gross Cooling Capacity Btu [kW]	70,000 [20.51]	70,000 [20.51]	70,000 [20.51]	70,000 [20.51]
EER/SEER ²	11 / NA	11 / NA	11 / NA	11 / NA
Nominal CFM/AHRI Rated CFM [L/s]	2400 / 2100 [1133 / 991]	2400 / 2100 [1133 / 991]	2400 / 2100 [1133 / 991]	2400 / 2100 [1133 / 991]
AHRI Net Cooling Capacity Btu [kW]	68,000 [19.92]	68,000 [19.92]	68,000 [19.92]	68,000 [19.92]
Net Sensible Capacity Btu [kW]	46,000 [13.48]	46,000 [13.48]	46,000 [13.48]	46,000 [13.48]
Net Latent Capacity Btu [kW]	22,000 [6.45]	22,000 [6.45]	22,000 [6.45]	22,000 [6.45]
IEER ²	12.9	12.9	12.9	12.9
Net System Power kW	6.18	6.18	6.18	6.18
Heating Performance (Gas)³				
Heating Input Btu [kW]	100,000 [29.3]	100,000 [29.3]	135,000 [39.55]	135,000 [39.55]
Heating Output Btu [kW]	82,000 [24.03]	82,000 [24.03]	110,700 [32.43]	110,700 [32.43]
Temperature Rise Range °F [°C]	20-50 [11.1-27.8]	20-50 [11.1-27.8]	30-60 [16.7-33.3]	30-60 [16.7-33.3]
Steady State Efficiency (%)	82	82	82	82
No. Burners	5	5	6	6
No. Stages	1	1	1	1
Gas Connection Pipe Size in. [mm]	0.5 [12.7]	0.5 [12.7]	0.5 [12.7]	0.5 [12.7]
Compressor				
No./Type	1 / Two-Stage Scroll	1 / Two-Stage Scroll	1 / Two-Stage Scroll	1 / Two-Stage Scroll
Outdoor Sound Rating (dB)⁴	83	83	83	83
Outdoor Coil—Fin Type	Louvered	Louvered	Louvered	Louvered
Tube Type	MicroChannel	MicroChannel	MicroChannel	MicroChannel
MicroChannel Depth in. [mm]	0.71 [18]	0.71 [18]	0.71 [18]	0.71 [18]
Face Area sq. ft. [sq. m]	16.4 [1.52]	16.4 [1.52]	16.4 [1.52]	16.4 [1.52]
Rows / FPI [FPcm]	1 / 23 [9]	1 / 23 [9]	1 / 23 [9]	1 / 23 [9]
Indoor Coil—Fin Type	Louvered	Louvered	Louvered	Louvered
Tube Type	MicroChannel	MicroChannel	MicroChannel	MicroChannel
MicroChannel Depth in. [mm]	1.26 [32]	1.26 [32]	1.26 [32]	1.26 [32]
Face Area sq. ft. [sq. m]	5.95 [0.55]	5.95 [0.55]	5.95 [0.55]	5.95 [0.55]
Rows / FPI [FPcm]	1 / 22 [9]	1 / 22 [9]	1 / 22 [9]	1 / 22 [9]
Refrigerant Control	TX Valve	TX Valve	TX Valve	TX Valve
Drain Connection No./Size in. [mm]	1 / 0.75 [19.05]	1 / 0.75 [19.05]	1 / 0.75 [19.05]	1 / 0.75 [19.05]
Outdoor Fan—Type	Propeller	Propeller	Propeller	Propeller
No. Used/Diameter in. [mm]	1 / 24 [609.6]	1 / 24 [609.6]	1 / 24 [609.6]	1 / 24 [609.6]
Drive Type/No. Speeds	Direct / 1	Direct / 1	Direct / 1	Direct / 1
CFM [L/s]	4200 [1982]	4200 [1982]	4200 [1982]	4200 [1982]
No. Motors/HP	1 / 0.5	1 / 0.5	1 / 0.5	1 / 0.5
Motor RPM	1075	1075	1075	1075
Indoor Fan—Type	FC Centrifugal	FC Centrifugal	FC Centrifugal	FC Centrifugal
No. Used/Diameter in. [mm]	1 / 11x10 [279x254]	1 / 11x10 [279x254]	1 / 11x10 [279x254]	1 / 11x10 [279x254]
Drive Type	Belt (Adjustable)	Belt (Adjustable)	Belt (Adjustable)	Belt (Adjustable)
No. Speeds	Single	Single	Single	Single
No. Motors	1	1	1	1
Motor HP	2	2	2	2
Motor RPM	1725	1725	1725	1725
Motor Frame Size	56	56	56	56
Filter—Type	Disposable	Disposable	Disposable	Disposable
Furnished	Yes	Yes	Yes	Yes
(NO.) Size Recommended in. [mm x mm x mm]	(4)2x16x16 [51x406x406]	(4)2x16x16 [51x406x406]	(4)2x16x16 [51x406x406]	(4)2x16x16 [51x406x406]
Refrigerant Charge Oz. [g]	67 [1899]	67 [1899]	67 [1899]	67 [1899]
Weights				
Net Weight lbs. [kg]	615 [279]	617 [280]	620 [281]	622 [282]
Ship Weight lbs. [kg]	648 [294]	650 [295]	653 [296]	655 [297]

See Page 13 for Notes.

[] Designates Metric Conversions

NOM. SIZES 6 TONS [21.1 kW]

Model RKKN- Series	(B,C)073YL10E	(B,C)073YM10E	(B,C)073YL13E	(B,C)073YM13E
Cooling Performance¹				
Gross Cooling Capacity Btu [kW]	70,000 [20.51]	70,000 [20.51]	70,000 [20.51]	70,000 [20.51]
EER/SEER ²	11 / NA	11 / NA	11 / NA	11 / NA
Nominal CFM/AHRI Rated CFM [L/s]	2400 / 2100 [1133 / 991]	2400 / 2100 [1133 / 991]	2400 / 2100 [1133 / 991]	2400 / 2100 [1133 / 991]
AHRI Net Cooling Capacity Btu [kW]	68,000 [19.92]	68,000 [19.92]	68,000 [19.92]	68,000 [19.92]
Net Sensible Capacity Btu [kW]	46,000 [13.48]	46,000 [13.48]	46,000 [13.48]	46,000 [13.48]
Net Latent Capacity Btu [kW]	22,000 [6.45]	22,000 [6.45]	22,000 [6.45]	22,000 [6.45]
IEER ²	12.9	12.9	12.9	12.9
Net System Power kW	6.18	6.18	6.18	6.18
Heating Performance (Gas)³				
Heating Input Btu [kW]	100,000 [29.3]	100,000 [29.3]	135,000 [39.55]	135,000 [39.55]
Heating Output Btu [kW]	82,000 [24.03]	82,000 [24.03]	110,700 [32.43]	110,700 [32.43]
Temperature Rise Range °F [°C]	20-50 [11.1-27.8]	20-50 [11.1-27.8]	30-60 [16.7-33.3]	30-60 [16.7-33.3]
Steady State Efficiency (%)	82	82	82	82
No. Burners	5	5	6	6
No. Stages	1	1	1	1
Gas Connection Pipe Size in. [mm]	0.5 [12.7]	0.5 [12.7]	0.5 [12.7]	0.5 [12.7]
Compressor				
No./Type	1 / Two-Stage Scroll	1 / Two-Stage Scroll	1 / Two-Stage Scroll	1 / Two-Stage Scroll
Outdoor Sound Rating (dB)⁴				
	83	83	83	83
Outdoor Coil—Fin Type				
Tube Type	Louvered	Louvered	Louvered	Louvered
MicroChannel Depth in. [mm]	MicroChannel	MicroChannel	MicroChannel	MicroChannel
Face Area sq. ft. [sq. m]	0.71 [18]	0.71 [18]	0.71 [18]	0.71 [18]
Rows / FPI [FPcm]	16.4 [1.52]	16.4 [1.52]	16.4 [1.52]	16.4 [1.52]
	1 / 23 [9]	1 / 23 [9]	1 / 23 [9]	1 / 23 [9]
Indoor Coil—Fin Type				
Tube Type	Louvered	Louvered	Louvered	Louvered
MicroChannel Depth in. [mm]	MicroChannel	MicroChannel	MicroChannel	MicroChannel
Face Area sq. ft. [sq. m]	1.26 [32]	1.26 [32]	1.26 [32]	1.26 [32]
Rows / FPI [FPcm]	5.95 [0.55]	5.95 [0.55]	5.95 [0.55]	5.95 [0.55]
Refrigerant Control	1 / 22 [9]	1 / 22 [9]	1 / 22 [9]	1 / 22 [9]
Drain Connection No./Size in. [mm]	TX Valve	TX Valves	TX Valves	TX Valves
	1 / 0.75 [19.05]	1 / 0.75 [19.05]	1 / 0.75 [19.05]	1 / 0.75 [19.05]
Outdoor Fan—Type				
No. Used/Diameter in. [mm]	Propeller	Propeller	Propeller	Propeller
Drive Type/No. Speeds	1 / 24 [609.6]	1 / 24 [609.6]	1 / 24 [609.6]	1 / 24 [609.6]
CFM [L/s]	Direct / 1	Direct / 1	Direct / 1	Direct / 1
No. Motors/HP	4200 [1982]	4200 [1982]	4200 [1982]	4200 [1982]
Motor RPM	1 / 0.5	1 / 0.5	1 / 0.5	1 / 0.5
	1075	1075	1075	1075
Indoor Fan—Type				
No. Used/Diameter in. [mm]	FC Centrifugal	FC Centrifugal	FC Centrifugal	FC Centrifugal
Drive Type	1 / 11x10 [279x254]	1 / 11x10 [279x254]	1 / 11x10 [279x254]	1 / 11x10 [279x254]
No. Speeds	Belt (Adjustable)	Belt (Adjustable)	Belt (Adjustable)	Belt (Adjustable)
No. Motors	Single	Single	Single	Single
Motor HP	1	1	1	1
Motor RPM	1.5	1.5	1.5	1.5
Motor Frame Size	1725	1725	1725	1725
	56	56	56	56
Filter—Type				
Furnished	Disposable	Disposable	Disposable	Disposable
(NO.) Size Recommended in. [mm x mm x mm]	Yes	Yes	Yes	Yes
	(4)2x16x16 [51x406x406]	(4)2x16x16 [51x406x406]	(4)2x16x16 [51x406x406]	(4)2x16x16 [51x406x406]
Refrigerant Charge Oz. [g]				
	67 [1899]	67 [1899]	67 [1899]	67 [1899]
Weights				
Net Weight lbs. [kg]	613 [278]	615 [279]	618 [280]	620 [281]
Ship Weight lbs. [kg]	646 [293]	648 [294]	651 [295]	653 [296]

See Page 13 for Notes.

[] Designates Metric Conversions

NOTES:

1. Cooling Performance is rated at 95° F ambient, 80° F entering dry bulb, 67° F entering wet bulb. Gross capacity does not include the effect of fan motor heat. AHRI capacity is net and includes the effect of fan motor heat. Units are suitable for operation to $\pm 20\%$ of nominal cfm. Units are certified in accordance with the Unitary Large Equipment certification program, which is based on AHRI Standard 340/360.
2. EER and IEER are rated at AHRI conditions and in accordance with DOE test procedures and AHRI Standard 340/360.
3. Heating Performance limit settings and rating data were established and approved under laboratory test conditions using American National Standard Institute standards. Ratings shown are for elevations up to 2000 feet. For elevations above 2000 feet, ratings should be reduced at the rate of 4% for each 1000 feet above sea level.
4. Outdoor Sound Rating shown is tested in accordance with AHRI Standard 270.

GROSS SYSTEMS PERFORMANCE DATA — RKKN-B073/RKKN-C073

wBE		ENTERING INDOOR AIR @ 80°F [26.7°C] dB _E ①										61°F [16.1°C]		59°F [15.0°C]		
		71°F [21.7°C]		67°F [19.4°C]		63°F [17.2°C]		61°F [16.1°C]		59°F [15.0°C]						
CFM [L/s]	DR ①	2310 [1090]	2100 [991]	1780 [840]	2310 [1090]	2100 [991]	1780 [840]	2310 [1090]	2100 [991]	1780 [840]	2310 [1090]	2100 [991]	1780 [840]	2310 [1090]	2100 [991]	1780 [840]
75 [23.9]	Total BTUH [kW]	84.0 [24.6]	82.5 [24.2]	80.2 [23.5]	79.1 [23.2]	77.7 [22.8]	75.5 [22.1]	73.8 [21.6]	72.4 [21.2]	70.4 [20.6]	70.9 [20.8]	69.7 [20.4]	67.7 [19.8]	68.0 [19.9]	66.8 [19.6]	64.9 [19.0]
	Sens BTUH [kW]	44.8 [13.1]	42.8 [12.5]	39.8 [11.6]	53.3 [15.6]	51.0 [14.9]	47.3 [13.9]	60.8 [17.8]	58.1 [17.0]	54.0 [15.8]	64.0 [18.7]	61.1 [17.9]	56.8 [16.6]	66.6 [19.5]	63.6 [18.6]	59.1 [17.3]
	Power	4.5	4.5	4.4	4.4	4.4	4.3	4.3	4.3	4.3	4.3	4.3	4.2	4.3	4.2	4.2
80 [26.7]	Total BTUH [kW]	82.4 [24.1]	80.9 [23.7]	78.7 [23.1]	77.5 [22.7]	76.1 [22.3]	74.0 [21.7]	72.2 [21.2]	70.9 [20.8]	68.9 [20.2]	69.3 [20.3]	68.1 [20.0]	66.2 [19.4]	66.4 [19.5]	65.2 [19.1]	63.4 [18.6]
	Sens BTUH [kW]	44.4 [13.0]	42.4 [12.4]	39.4 [11.5]	52.9 [15.5]	50.6 [14.8]	47.0 [13.8]	60.4 [17.7]	57.7 [16.9]	53.6 [15.7]	63.6 [18.6]	60.7 [17.8]	56.4 [16.5]	66.2 [19.4]	63.3 [18.5]	58.8 [17.2]
	Power	4.8	4.7	4.7	4.7	4.6	4.6	4.6	4.6	4.5	4.6	4.5	4.5	4.5	4.5	4.4
85 [29.4]	Total BTUH [kW]	80.6 [23.6]	79.2 [23.2]	77.0 [22.6]	75.7 [22.2]	74.4 [21.8]	72.3 [21.2]	70.4 [20.6]	69.1 [20.3]	67.2 [19.7]	67.6 [19.8]	66.3 [19.4]	64.5 [18.9]	64.6 [18.9]	63.4 [18.6]	61.7 [18.1]
	Sens BTUH [kW]	43.8 [12.8]	41.9 [12.3]	38.9 [11.4]	52.3 [15.3]	50.0 [14.7]	46.5 [13.6]	59.8 [17.5]	57.2 [16.7]	53.1 [15.6]	63.0 [18.5]	60.2 [17.6]	55.9 [16.4]	64.6 [18.9]	62.7 [18.4]	58.2 [17.1]
	Power	5.0	5.0	4.9	4.9	4.9	4.8	4.8	4.9	4.8	4.8	4.8	4.7	4.8	4.7	4.7
90 [32.2]	Total BTUH [kW]	78.6 [23.0]	77.2 [22.6]	75.1 [22.0]	73.7 [21.6]	72.4 [21.2]	70.4 [20.6]	68.4 [20.0]	67.2 [19.7]	65.3 [19.1]	65.6 [19.2]	64.4 [18.9]	62.6 [18.3]	62.6 [18.3]	61.5 [18.0]	59.8 [17.5]
	Sens BTUH [kW]	43.0 [12.6]	41.1 [12]	38.2 [11.2]	51.5 [15.1]	49.2 [14.4]	45.7 [13.4]	59.0 [17.3]	56.4 [16.5]	52.4 [15.3]	62.2 [18.2]	59.4 [17.4]	55.2 [16.2]	62.6 [18.3]	61.5 [18.0]	57.5 [16.9]
	Power	5.3	5.3	5.2	5.2	5.2	5.1	5.2	5.1	5.1	5.1	5.1	5.0	5.1	5.0	5.0
95 [35]	Total BTUH [kW]	76.4 [22.4]	75.1 [22.0]	73.0 [21.4]	71.6 [21.0]	70.3 [20.6]	68.3 [20.0]	66.2 [19.4]	65.0 [19.1]	63.2 [18.5]	63.4 [18.6]	62.3 [18.2]	60.5 [17.7]	60.4 [17.7]	59.3 [17.4]	57.7 [16.9]
	Sens BTUH [kW]	42.0 [12.3]	40.1 [11.8]	37.3 [10.9]	50.5 [14.8]	48.3 [14.1]	44.8 [13.1]	58.0 [17.0]	55.4 [16.2]	51.5 [15.1]	61.2 [17.9]	58.4 [17.1]	54.3 [15.9]	60.4 [17.7]	59.3 [17.4]	56.6 [16.6]
	Power	5.6	5.6	5.5	5.6	5.5	5.4	5.5	5.4	5.4	5.4	5.4	5.3	5.4	5.3	5.3
100 [37.8]	Total BTUH [kW]	74.0 [21.7]	72.7 [21.3]	70.7 [20.7]	69.2 [20.3]	67.9 [19.9]	66.1 [19.4]	63.8 [18.7]	62.7 [18.4]	61.0 [17.9]	61.0 [17.9]	59.9 [17.6]	58.3 [17.1]	58.0 [17.0]	57.0 [16.7]	55.4 [16.2]
	Sens BTUH [kW]	40.8 [11.9]	39.0 [11.4]	36.2 [10.6]	49.3 [14.5]	47.1 [13.8]	43.8 [12.8]	56.8 [16.6]	54.3 [15.9]	50.4 [14.8]	60.0 [17.6]	57.3 [16.8]	53.2 [15.6]	58.0 [17.0]	57.0 [16.7]	55.4 [16.2]
	Power	6.0	5.9	5.9	5.9	5.9	5.8	5.8	5.8	5.7	5.8	5.7	5.6	5.7	5.7	5.6
105 [40.6]	Total BTUH [kW]	71.4 [20.9]	70.2 [20.6]	68.2 [20.0]	66.6 [19.5]	65.4 [19.2]	63.6 [18.6]	61.3 [18.0]	60.2 [17.6]	58.5 [17.1]	58.4 [17.1]	57.4 [16.8]	55.8 [16.3]	55.5 [16.3]	54.5 [16.0]	53.0 [15.5]
	Sens BTUH [kW]	39.3 [11.5]	37.6 [11.0]	34.9 [10.2]	47.9 [14.0]	45.8 [13.4]	42.5 [12.5]	55.4 [16.2]	52.9 [15.5]	49.1 [14.4]	58.4 [17.1]	55.9 [16.4]	51.9 [15.2]	55.5 [16.3]	54.5 [16.0]	53.0 [15.5]
	Power	6.4	6.3	6.2	6.3	6.2	6.1	6.2	6.1	6.1	6.1	6.1	6.0	6.1	6.0	6.0
110 [43.3]	Total BTUH [kW]	68.7 [20.1]	67.4 [19.8]	65.6 [19.2]	63.8 [18.7]	62.7 [18.4]	60.9 [17.9]	58.5 [17.1]	57.4 [16.8]	55.8 [16.3]	55.6 [16.3]	54.6 [16.0]	53.1 [15.6]	52.7 [15.4]	51.7 [15.2]	50.3 [14.7]
	Sens BTUH [kW]	37.7 [11.1]	36.0 [10.6]	33.5 [9.8]	46.3 [13.6]	44.2 [13.0]	41.1 [12.0]	53.7 [15.7]	51.3 [15.0]	47.7 [14.0]	55.6 [16.3]	54.4 [15.9]	50.5 [14.8]	52.7 [15.4]	51.7 [15.2]	50.3 [14.7]
	Power	6.8	6.7	6.6	6.7	6.6	6.5	6.6	6.6	6.4	6.5	6.5	6.4	6.5	6.4	6.4
115 [46.1]	Total BTUH [kW]	65.7 [19.2]	64.5 [18.9]	62.7 [18.4]	60.8 [17.8]	59.7 [17.5]	58.1 [17.0]	55.5 [16.3]	54.5 [16.0]	53.0 [15.5]	52.6 [15.4]	51.7 [15.2]	50.3 [14.7]	49.7 [14.6]	48.8 [14.3]	47.4 [13.9]
	Sens BTUH [kW]	35.9 [10.5]	34.3 [10.0]	31.8 [9.3]	44.4 [13.0]	42.4 [12.4]	39.4 [11.6]	51.9 [15.2]	49.6 [14.5]	46.1 [13.5]	52.6 [15.4]	51.7 [15.2]	48.9 [14.3]	49.7 [14.6]	48.8 [14.3]	47.4 [13.9]
	Power	7.2	7.1	7.0	7.1	7.0	6.9	7.0	7.0	6.8	7.0	6.9	6.8	6.9	6.9	6.8
120 [48.9]	Total BTUH [kW]	62.5 [18.3]	61.4 [18.0]	59.7 [17.5]	57.6 [16.9]	56.6 [16.6]	55.0 [16.1]	52.3 [15.3]	51.4 [15.0]	49.9 [14.6]	49.5 [14.5]	48.6 [14.2]	47.2 [13.8]	46.5 [13.6]	45.7 [13.4]	44.4 [13.0]
	Sens BTUH [kW]	33.8 [9.9]	32.3 [9.5]	30.0 [8.8]	42.4 [12.4]	40.5 [11.9]	37.6 [11.0]	49.9 [14.6]	47.6 [14.0]	44.2 [13.0]	49.5 [14.5]	48.6 [14.2]	47.0 [13.8]	46.5 [13.6]	45.7 [13.4]	44.4 [13.0]
	Power	7.6	7.5	7.4	7.5	7.5	7.4	7.4	7.4	7.3	7.4	7.3	7.2	7.4	7.3	7.2
125 [51.7]	Total BTUH [kW]	59.1 [17.3]	58.0 [17.0]	56.4 [16.5]	54.2 [15.9]	53.3 [15.6]	51.8 [15.2]	48.9 [14.3]	48.0 [14.1]	46.7 [13.7]	46.1 [13.5]	45.2 [13.3]	44.0 [12.9]	43.1 [12.6]	42.3 [12.4]	41.2 [12.1]
	Sens BTUH [kW]	31.6 [9.3]	30.2 [8.8]	28.0 [8.2]	40.1 [11.8]	38.3 [11.2]	35.6 [10.4]	47.6 [13.9]	45.5 [13.3]	42.2 [12.4]	46.1 [13.5]	45.2 [13.3]	44.0 [12.9]	43.1 [12.6]	42.3 [12.4]	41.2 [12.1]
	Power	8.1	8.0	7.9	8.0	7.9	7.8	7.9	7.8	7.7	7.9	7.8	7.7	7.8	7.8	7.7

DR — Depression ratio
dB_E — Entering air dry bulb
wBE — Entering air wet bulb

Total — Total capacity x 1000 BTUH
Sens — Sensible capacity x 1000 BTUH
Power — KW input

NOTES: ① When the entering air dry bulb is other than 80°F [27°C], adjust the sensible capacity from the table by adding [1.10 x CFM x (1 - DR) x (dB_E - 80)].

[] Designates Metric Conversions

AIRFLOW PERFORMANCE — RKKN-B073/RKKN-C073 THREE PHASE BELT DRIVE

Air Flow CFM [L/s]	Capacity 6 Ton [21.10 kW] Voltage 208/230-460 & 575—3 Phase																													
	External Static Pressure—Inches of Water [kPa]																													
	0.1 [.02]	0.2 [.05]	0.3 [.07]	0.4 [.10]	0.5 [.12]	0.6 [.15]	0.7 [.17]	0.8 [.20]	0.9 [.22]	1.0 [.25]	1.1 [.27]	1.2 [.30]	1.3 [.32]	1.4 [.35]	1.5 [.37]	0.1 [.02]	0.2 [.05]	0.3 [.07]	0.4 [.10]	0.5 [.12]	0.6 [.15]	0.7 [.17]	0.8 [.20]	0.9 [.22]	1.0 [.25]	1.1 [.27]	1.2 [.30]	1.3 [.32]	1.4 [.35]	1.5 [.37]
1800 [850]	—	—	—	785	850	895	930	975	1000	1030	1065	1100	1135	1170	1205	1240	1275	1310	1345	1380	1415	1450	1485	1520	1555	1590	1625	1660	1695	1730
1900 [897]	—	—	785	830	875	915	955	990	1025	1060	1095	1130	1165	1200	1235	1270	1305	1340	1375	1410	1445	1480	1515	1550	1585	1620	1655	1690	1725	1760
2000 [944]	—	775	815	860	900	940	980	1020	1060	1100	1140	1180	1220	1260	1300	1340	1380	1420	1460	1500	1540	1580	1620	1660	1700	1740	1780	1820	1860	1900
2100 [991]	—	810	850	890	930	970	1010	1050	1090	1130	1170	1210	1250	1290	1330	1370	1410	1450	1490	1530	1570	1610	1650	1690	1730	1770	1810	1850	1890	1930
2200 [1038]	780	825	865	905	945	985	1025	1065	1105	1145	1185	1225	1265	1305	1345	1385	1425	1465	1505	1545	1585	1625	1665	1705	1745	1785	1825	1865	1905	
2300 [1085]	815	860	900	940	980	1020	1060	1100	1140	1180	1220	1260	1300	1340	1380	1420	1460	1500	1540	1580	1620	1660	1700	1740	1780	1820	1860	1900	1940	
2400 [1133]	845	890	930	970	1010	1050	1090	1130	1170	1210	1250	1290	1330	1370	1410	1450	1490	1530	1570	1610	1650	1690	1730	1770	1810	1850	1890	1930	1970	
2500 [1180]	870	915	955	995	1035	1075	1115	1155	1195	1235	1275	1315	1355	1395	1435	1475	1515	1555	1595	1635	1675	1715	1755	1795	1835	1875	1915	1955	1995	
2600 [1227]	900	945	985	1025	1065	1105	1145	1185	1225	1265	1305	1345	1385	1425	1465	1505	1545	1585	1625	1665	1705	1745	1785	1825	1865	1905	1945	1985	2025	
2700 [1274]	930	975	1015	1055	1095	1135	1175	1215	1255	1295	1335	1375	1415	1455	1495	1535	1575	1615	1655	1695	1735	1775	1815	1855	1895	1935	1975	2015	2055	
2800 [1321]	960	1005	1045	1085	1125	1165	1205	1245	1285	1325	1365	1405	1445	1485	1525	1565	1605	1645	1685	1725	1765	1805	1845	1885	1925	1965	2005	2045	2085	

NOTE: L-Drive left of bold line, M-Drive right of bold line.

Drive Package	L						M							
Motor H.P. [W]	1 1/2 [1119]						1 1/2 [1119]							
Blower Sheave	6.4" Pitch Diameter						6.4" Pitch Diameter							
Motor Sheave	2.8"-3.8" Pitch Diameter—Adj.						3.4"-4.4" Pitch Diameter—Adj.							
Turns Open	0	1	2	3	4	5	6	0	1	2	3	4	5	6
RPM	1100	1050	1000	945	895	845	780	1295	1230	1195	1145	1100	1050	1000

NOTE: Factory sheave settings are shown in bold print.

[] Designates Metric Conversions

ELECTRICAL DATA – RKKN SERIES

		(B,C)073CL	(B,C)073CM	(B,C)073DL	(B,C)073DM	(B,C)073YL	(B,C)073YM
Unit Information	Unit Operating Voltage Range	187-253	187-253	414-506	414-506	518-632	518-632
	Volts	208/230	208/230	460	460	575	575
	Phase	3	3	3	3	3	3
	Hz	60	60	60	60	60	60
	Minimum Circuit Ampacity	31	31	16	16	11	11
	Minimum Overcurrent Protection	35	35	20	20	15	15
	Maximum Overcurrent Protection	45	45	20	20	15	15
Compressor Motor	No.	1	1	1	1	1	1
	Volts	208/230	208/230	460	460	575	575
	Phase	3	3	3	3	3	3
	RPM	3450	3450	3450	3450	3450	3450
	HP, Compressor 1	5	5	5	5	5	5
	Amps (RLA), Comp. 1	17.6	17.6	8.5	8.5	6.3	6.3
	Amps (LRA), Comp. 1	136	136	66.1	66.1	55.3	55.3
Condenser Motor	No.	1	1	1	1	1	1
	Volts	208/230	208/230	460	460	575	575
	Phase	1	1	1	1	1	1
	HP	1/2	1/2	1/2	1/2	1/2	1/2
	Amps (FLA, each)	2.3	2.3	1.5	1.5	1	1
	Amps (LRA, each)	5.6	5.6	3.1	3.1	2.2	2.2
Evaporator Fan	No.	1	1	1	1	1	1
	Volts	208/230	208/230	460	460	575	575
	Phase	3	3	3	3	3	3
	HP	2	2	2	2	1 1/2	1 1/2
	Amps (FLA, each)	6.2	6.2	3	3	2.3	2.3
	Amps (LRA, each)	47	47	24	24	13.1	13.1

GAS HEAT / ELECTRIC COOLING PACKAGE

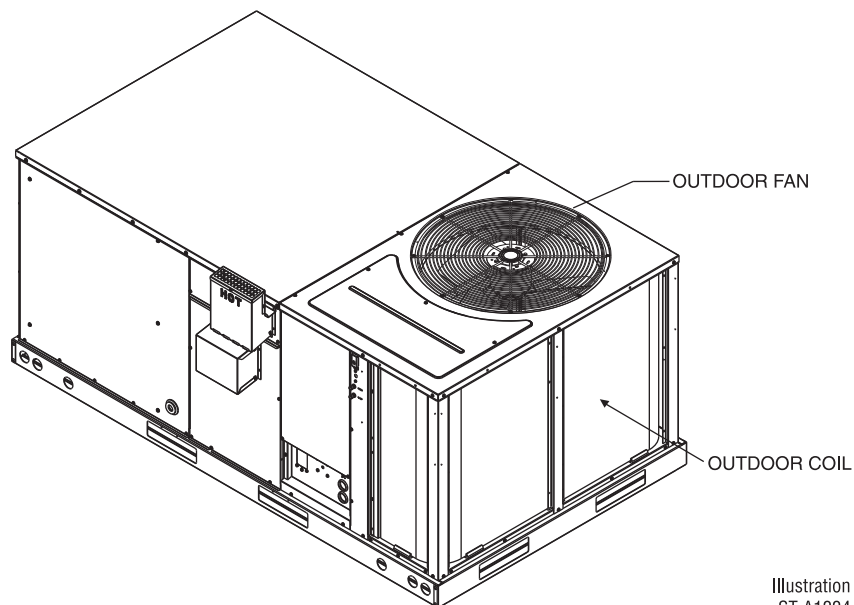
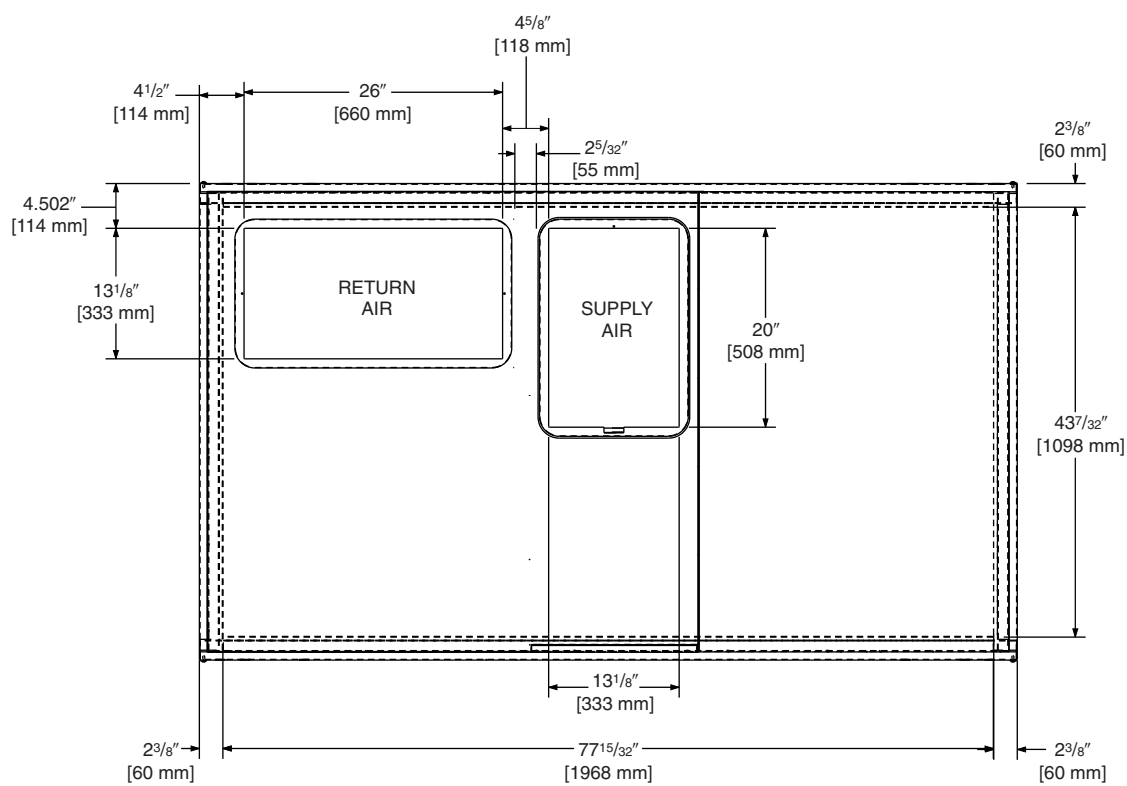

Illustration
ST-A1224

TOP VIEW



[] Designates Metric Conversions

Illustration
ST-A1143

GAS HEAT / ELECTRIC COOLING PACKAGE

BACK VIEW

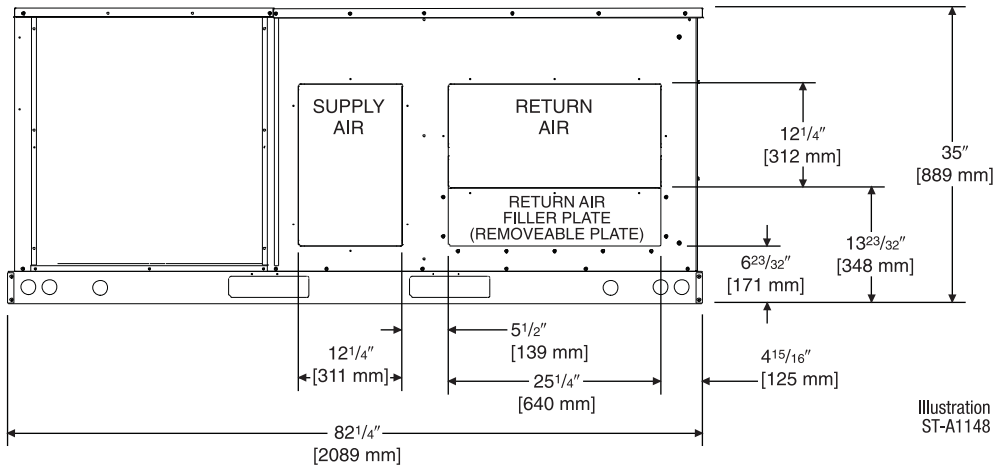

SIDE VIEW

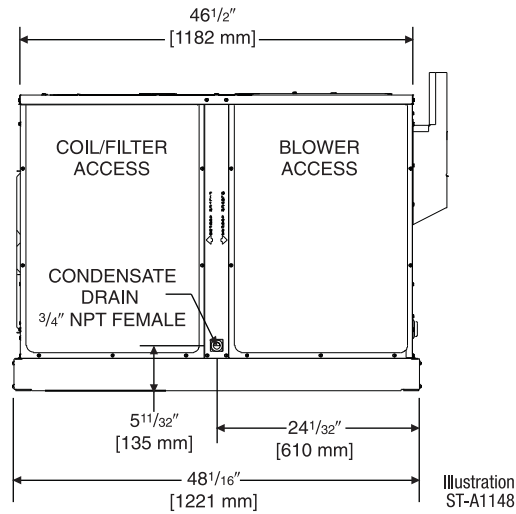

FRONT VIEW

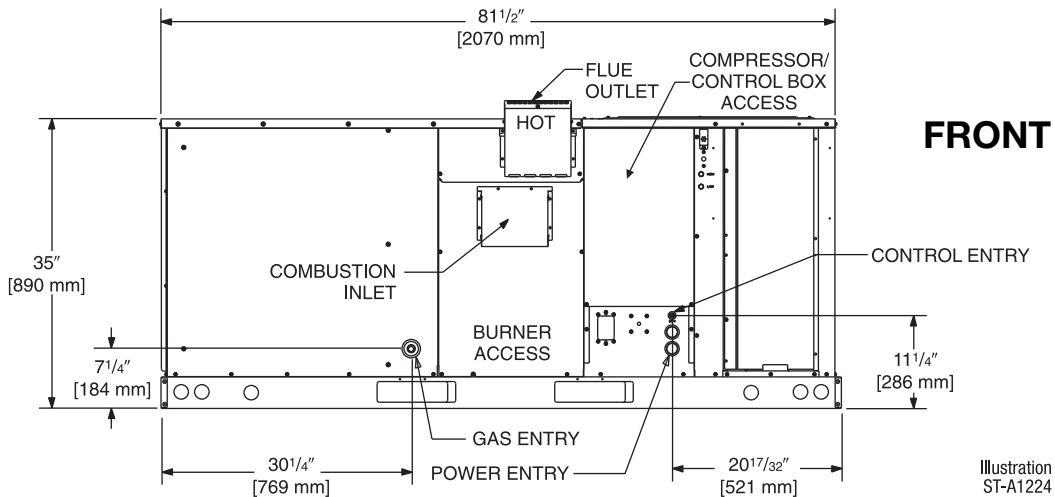

[] Designates Metric Conversions

WEIGHTS

Accessory	6 Ton [21.1 kW]	
	Shipping	Operating
	lbs [kg]	lbs [kg]
Economizer with Smoke Detector	76 [34]	75 [34]
Economizer without Smoke Detector	73 [33]	72 [33]
Power Exhaust	19 [9]	16 [7]
Fresh Air Damper (Manual)	11 [5]	9 [4]
Fresh Air Damper (Motorized)	13 [6]	11 [5]
Roof Curb 14"	92 [42]	88 [40]
Roof Curb 24"	108 [49]	104 [47]
Concentric Diffuser 18" Flush	37 [17]	26 [12]
Concentric Diffuser 20" Flush	54 [24]	42 [19]
Side Discharge Concentric Diffuser RXRN-FA60	35 [16]	20 [9]
Side Discharge Concentric Diffuser RXRN-FA65	55 [25]	40 [18]
VFD Kit	7 [3]	5 [2]

CENTER OF GRAVITY (C.G.)

Capacity Tons [kW]	A in. [mm]	B in. [mm]
6 [21.1]	38 ¹ / ₄ [972]	25 ³ / ₄ [654]

Capacity Tons [kW]	Corner Weights by Percentage			
	A	B	C	D
6 [21.1]	22%	27%	23%	28%

CLEARANCES (6 Ton [21.1 kW] Models)

The following minimum clearances are recommended for proper unit performance and serviceability.

Recommended Clearance in. [mm]	Location
48 [1219]	A - Front
18 [457]	B - Condenser Coil
12 [305]	C - Duct Side
36 [914]	D - Evaporator End
60 [1524]	E - Above

*Without Economizer. 57" [1448 mm] With Economizer

NOTE: Supply duct may be installed with "0" inch clearance to combustible materials, provided 1" [25.4 mm] minimum Fiberglass insulation is applied either inside or on the outside of the duct.

LIFTING DETAIL

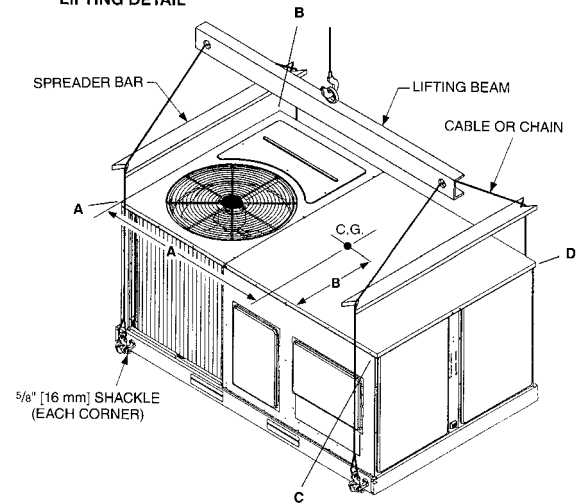

[] Designates Metric Conversions

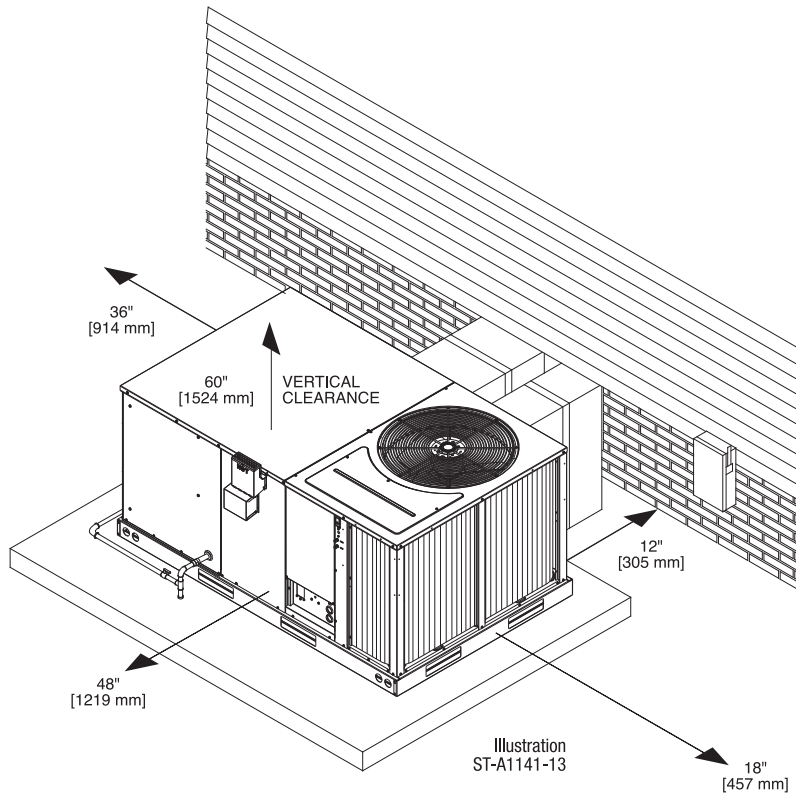

ACCESSORY EQUIPMENT

Accessory Description	Model Application	Accessory Model No.	Factory Installed
Roofcurb, 14"	RKKN-(B,C)073	RXKG-CAD14	No
Roofcurb, 24"	RKKN-(B,C)073	RXKG-CAD24	No
Roofcurb adapters	RKKN-(B,C)073	RXXR-CCCE50	No
Economizer (JADE), with single enthalpy ②	RKKN-B073	AXRD-01RCCAM3	Yes
Economizer (JADE), with smoke detector ②	RKKN-B073	AXRD-01RCCBM3	Yes
Dual enthalpy kit for economizer (JADE)	RKKN-B073	RXXR-AV04	No
Economizer (DDC) with single enthalpy ②	RKKN-C073	AXRD-01RHCCM3	Yes
Economizer (DDC) with smoke detector ②	RKKN-C073	AXRD-01RHCDM3	Yes
Dual enthalpy kit for economizer (DDC)	RKKN-C073	RXXR-AV03	No
CO ² sensor	RKKN-(B,C)073	RXXR-AR02	No
Power exhaust (C, D, Y voltages)	RKKN-(B,C)073	AXRX-BGF03(C,D,Y)	No
Fresh air damper, manual	RKKN-(B,C)073	AXRF-FCA1	No
Fresh air damper, motorized	RKKN-(B,C)073	AXRF-FCB1	No
Rectangular-to-round 20" duct adapters for concentric diffuser	RKKN-(B,C)073	RXMC-CC04	No
Concentric diffuser 20", step type	RKKN-(B,C)073	RXRN-FA65	No
Concentric diffuser 20", flush type	RKKN-(B,C)073	RXRN-FA75	No
Louver kit, 3-sided	RKKN-(B,C)073	AXRX-AAD01B	Yes
Compressor time delay	RKKN-B073	RXMD-B04	No
Low ambient control	RKKN-(B,C)073	RXXR-A04	Yes
Convenience outlet (requires separate power supply)	RKKN-(B,C)073	RXXR-AN02	Yes
Service disconnect switch	RKKN-(B,C)073	RXXR-AP01	Yes
LP conversion kit for Honeywell gas valve (see note 1)	RKKN-(B,C)073	RXGJ-EP94D	No
Freeze stat control	RKKN-B073	RXXR-AM04	Yes
Canadian high-altitude kit for natural gas only (see note 1)	RKKN-(B,C)073	RXXR-AH01	No
Comfort Alert	RKKN-C073	RXXR-AZ01	Yes
BACnet® Communication Card	RKKN-C073	RXXR-AY01	No
LonWorks™ Communication Card	RKKN-C073	RXXR-AY02	No
VFD Kit, 208/230V, Non-communicating	RKKN-B073C	RXXR-NC02	No
VFD Kit, 460V, Non-communicating	RKKN-B073C	RXXR-ND02	No
VFD Kit, 208/230V, Communicating	RKKN-C073C	RXXR-PC02	No
VFD Kit, 460V, Communicating	RKKN-C073D	RXXR-PD02	No

*Voltage C = 208/230 VAC-3PH-60HZ D = 460 VAC-3PH-60HZ
 Y = 575 VAC-3PH-60HZ

- NOTES:** 1. If a unit is to be converted to operate on LP gas above 2000 ft. in Canada, the conversion kits contain the necessary orifices and instructions to de-rate the input for 2000-4500 ft.
 2. Economizer is designed for downflow or horizontal applications.

[] Designates Metric Conversions

FLUSH MOUNT ROOM TEMPERATURE SENSORS FOR NETWORKED DDC APPLICATIONS



ROOM TEMPERATURE SENSOR with TIMED OVERRIDE BUTTON

RHC-ZNS1

10k Ω room temperature sensor transmits room temperature to DDC system. Timed override button allows tenant to change from unoccupied temperature setpoint to occupied temperature setpoint for a preset time.



ROOM TEMPERATURE SENSOR with TIMED OVERRIDE BUTTON and STATUS INDICATOR

RHC-ZNS2

10k Ω room temperature sensor transmits room temperature to DDC system. Timed override button allows tenant to change from unoccupied temperature setpoint to occupied temperature setpoint for a preset time. Status Indicator Light transmits ALARM flash code to occupied space.



ROOM TEMPERATURE SENSOR with SETPOINT ADJUSTMENT and TIMED OVERRIDE BUTTON

RHC-ZNS3

10k Ω room temperature sensor with setpoint adjustment transmits room temperature to DDC system along with desired occupied room temperature setpoint. Timed override button allows tenant to change from unoccupied temperature setpoint to occupied temperature setpoint for a preset time.

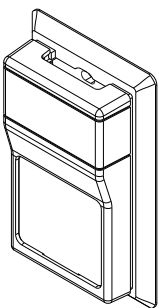

ROOM HUMIDITY SENSOR

RHC-ZNS4

Transmits room relative humidity to DDC System.

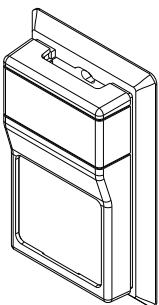

ROOM TEMPERATURE AND RELATIVE HUMIDITY SENSOR

RHC-ZNS5

Transmits room temperature and relative humidity to DDC System.

COMMUNICATION CARDS

Field Installed



BACnet® COMMUNICATION CARD RXX-AY01

The field installed BACnet® Communication Card allows the RTU-C unit controller to communicate with a third party building management system that supports the BACnet Application Specific Controller device profile. The BACnet® Communication Module plugs onto the unit RTU-C controller and allows communication between the RTU-C and the BACnet MSTP network.



LonWorks® COMMUNICATION CARD RXX-AY02

The field installed LonWorks® Communication Card allows the RTU-C unit controller to communicate with a third party building management system that supports the LonMark Space Comfort Controller (SCC) functional profile or LonMark Discharge Air Controller (DAC) functional profile. The LonMark Communication Module plugs onto the RTU-C controller and allows communication between the RTU-C and a LonWorks Network.

ROOFCURB ADAPTERS

Old Models

COMMERCIAL PACKAGE UNIT
(6.5 & 7.5 TON [23-26 kW])
 (-)RCF, (-)REF, (-)RGF131 & 201, RGF150

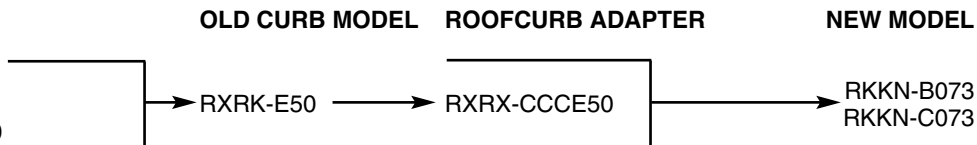

[] Designates Metric Conversions

ECONOMIZERS (JADE) – FOR RKKN-B073

AXRD-01RCCAM3—6 Ton [21.1 kW] Models
AXRD-01RCCBM3—6 Ton [21.1 kW] Models

RXXR-AV04—3-6 Ton [10.6-21.1 kW] Models

RXXR-AR02—3-6 Ton [10.6-21.1 kW] Models

Single Enthalpy (with Barometric Relief)
Single Enthalpy and Smoke Detector

Dual Enthalpy Kit

Optional CO₂ Sensor

- Features **Honeywell JADE™** Digital Controls
- Available factory installed or field accessory
- Gear Driven Direct Drive Actuator
- Fully Modulating (0-100%)
- Ultra Low Leak Dampers meet California Title 24 requirements
- Horizontal or Downflow Applications
- Slip-In Design for Easy Installations
- Plug-In Polarized 12-pin Electrical Connections
- Pre-configuring—No Field Adjustments Necessary
- Standard Barometric Relief Damper Provided
- Single Enthalpy with Dual Enthalpy upgrade kit
- CO₂ Input Sensor Available (field installed)
- Economizer slips in complete for downflow or horizontal duct applications
- Field assembled hood ships with Economizer
- Field installed power exhaust available.

[] Designates Metric Conversions

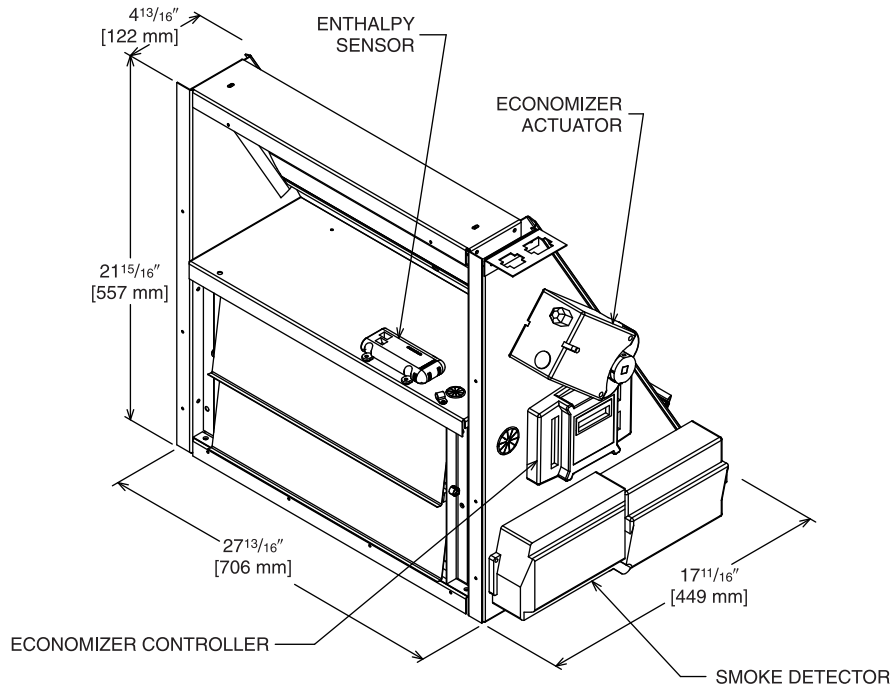
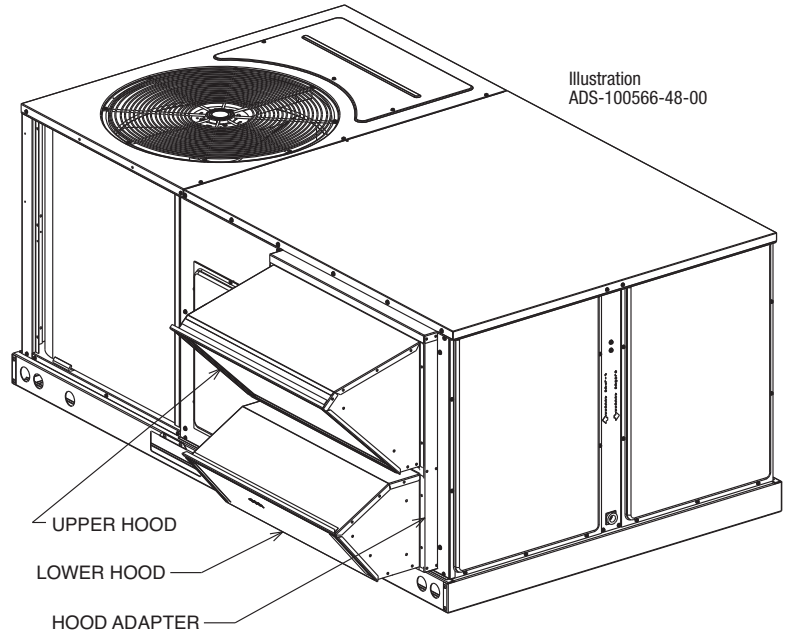

ECONOMIZERS (DDC)—FOR RKKN-C073

AXRD-01RHCCM3—6 Ton [21.1 kW] Models

AXRD-01RHCDM3—6 Ton [21.1 kW] Models

RXXR-AV03—6 Ton [21.1 kW] Models

RXXR-AR02—6 Ton [21.1 kW] Models

Single Enthalpy

Single Enthalpy and smoke detector

Dual Enthalpy Kit

Optional CO₂ Sensor

- Features **Honeywell** Controls
- Available factory installed or field accessory
- Gear Driven Direct Drive Actuator
- Fully Modulating (0-100%)
- Extra Low Leakage Dampers California Title 24 Compliant
- Horizontal or Downflow Applications
- Slip-In Design for Easy Installations
- Plug-In Polarized 12-pin Electrical Connections
- Pre-configuring—No Field Adjustments Necessary
- Standard Barometric Relief Damper Provided
- Single Enthalpy with Dual Enthalpy upgrade kit
- CO₂ Input Sensor Available (field installed)
- Economizer ships in complete for downflow or horizontal duct applications
- Field assembled hood ships with Economizer
- Optional Remote minimum position (Honeywell #S963B1128) is available from Rheem Parts.
- Field installed power exhaust available
- If connected to a Building Automation System (BAS), all economizer functions can be viewed on the (BAS), or 16 x 2 LCD screen
- If connected to thermostat, all economizer functions can be viewed on 16 x 2 LCD screen

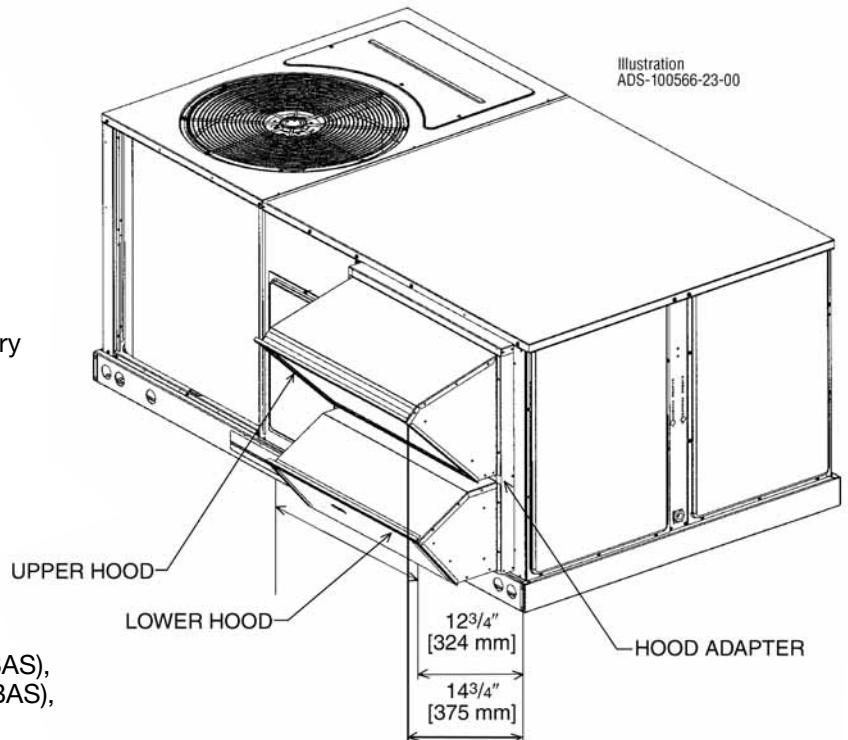

[] Designates Metric Conversions

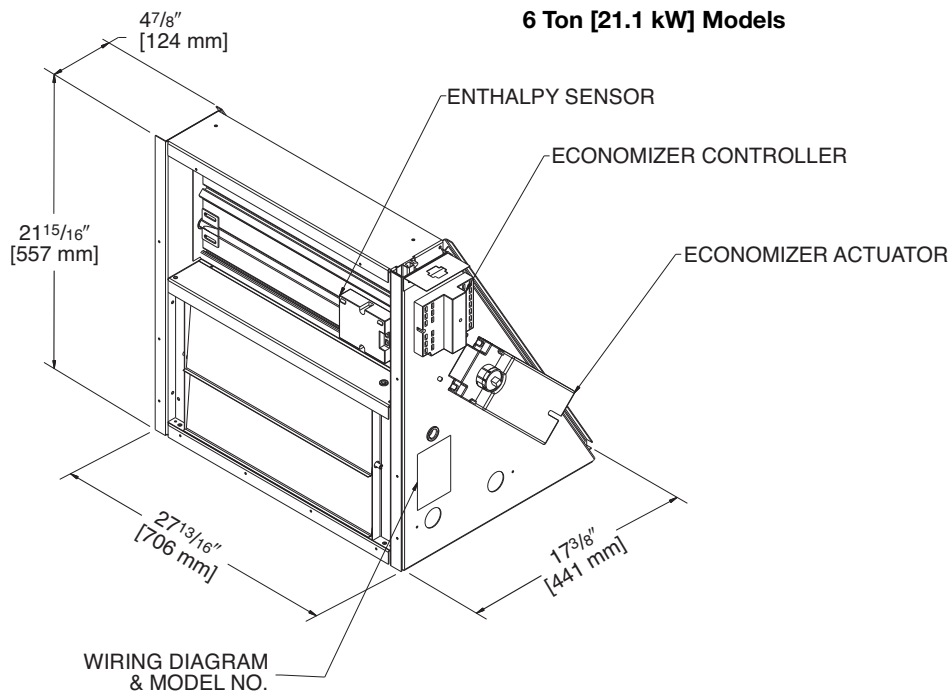

INTEGRAL POWER EXHAUST FOR ECONOMIZER (FIELD INSTALLED ONLY)

AXRX-BGF03(C,D,Y) – RKKN 6 Ton [21.1 kW]

- For **Honeywell** economizer.
- Downflow or horizontal applications.
- Requires separate 208-230 volt – 1 PH power supply with disconnect or requires separate 460V – 3 PH power supply with disconnect.
- Adjustable switch on economizer, factory preset to energize power exhaust at 95% outside air position.
- Polarized plug connects power exhaust relay to economizer.

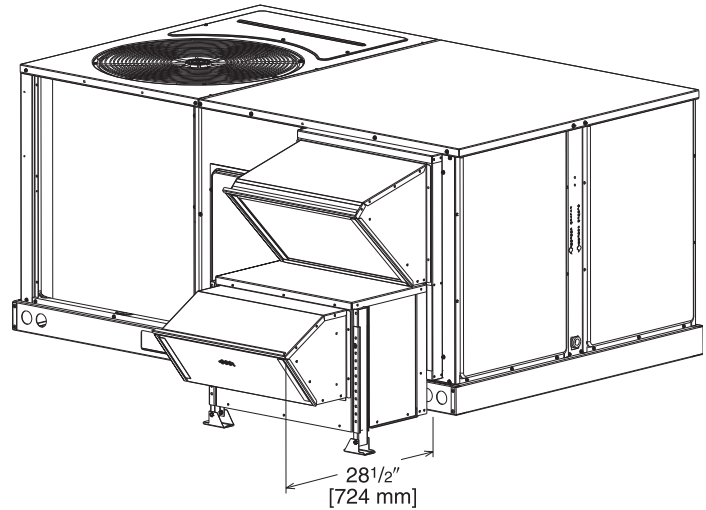

POWER EXHAUST KIT FOR AXRD-01RCCAM3, AXRD-01CCBM3, AXRD-01RHCCM3 & AXRD-01RHCDM3 ECONOMIZERS

Model No.	No. of Fans	Volts	Phase	Watts (ea.)	High Speed		FLA (ea.)	LRA (ea.)
					CFM ①	RPM		
AXRX-BGF03C	1	208/230	1	1000	2500	1725	4.4	23.7
AXRX-BGF03D	1	460	1	800	2370	1620	1.8	4.1
AXRX-BGF03Y ②	1	575	1	800	2370	1620	1.5	3.3

① CFM is at 0" W.C. external static pressure.

② Unit includes 575 to 460 Volt step-down transformer.

FRESH AIR DAMPER

RKKN 6 Ton [21.1 kW] Models

AXRF-FCA1 (Manual)

AXRF-FCB1 (Motorized)

[] Designates Metric Conversions

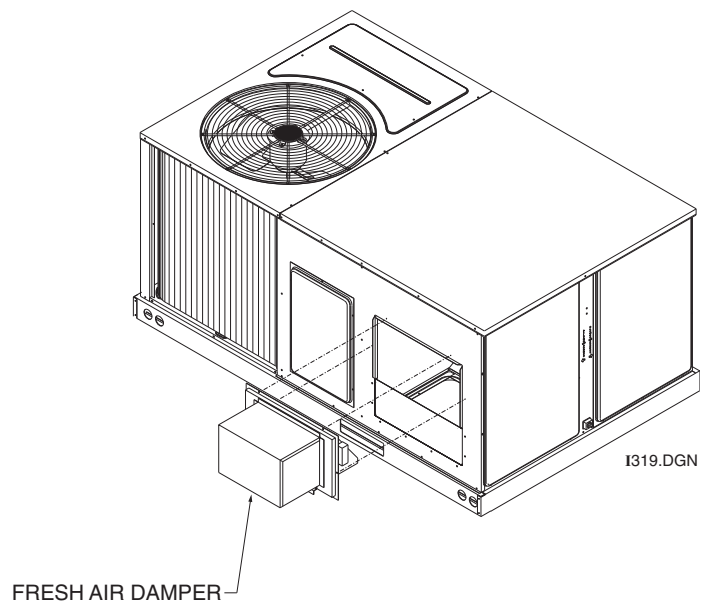

DUCT ADAPTERS (RKKN-B 6 Ton [21.1 kW] Models) Rectangular to Round Transitions (Downflow) RXMC-CC04 20" [508 mm] Round

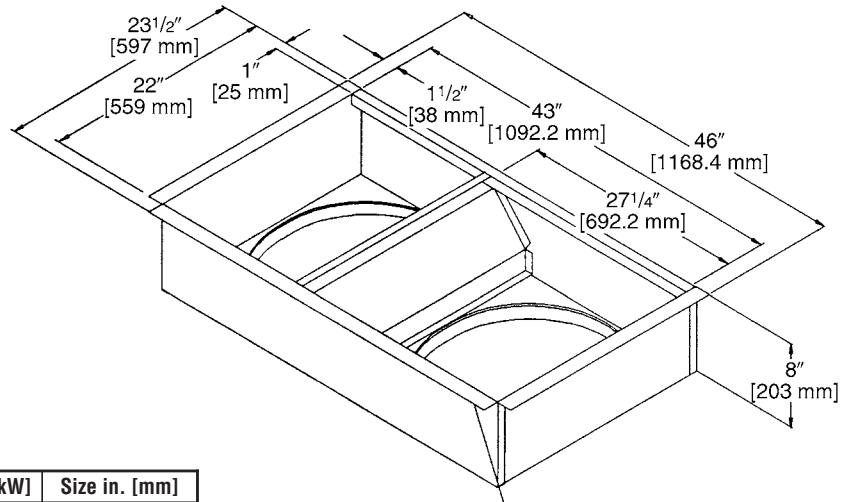

Accessory Model No.	Model Application Tons [kW]	Size in. [mm]
RXMC-CB03	3-5 [10.6-17.6]	18 [457] Round
RXMC-CC04	6 [21.1]	20 [508] Round

PLACE 1/8" [3.18 mm] X 1/2" [12.7 mm] GASKET
ON UNDERSIDE OF 1 1/2" [38.1 mm] FLANGE

[] Designates Metric Conversions

SIDE DISCHARGE CONCENTRIC DIFFUSER

RXRN-FA65 (6 Ton [21.1 kW] Model)

For Use With Duct Adapter (RXMC)

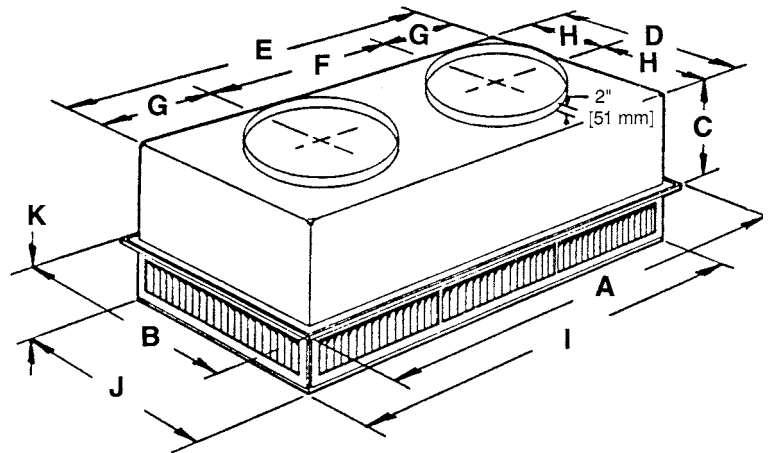

DIMENSIONAL DATA

Model No.	A	B	C	D	E	F	G	H	I	J	K	Duct Size
RXRN-FA65	47 ⁵ / ₈ " [1210 mm]	29 ⁵ / ₈ " [752 mm]	14 ³ / ₈ " [365 mm]	27 ¹ / ₂ " [699 mm]	45 ¹ / ₂ " [1156 mm]	22 ¹ / ₂ " [572 mm]	11 ¹ / ₂ " [292 mm]	13 ³ / ₄ " [349 mm]	45 ¹ / ₂ " [1156 mm]	27 ¹ / ₂ " [699 mm]	8 ¹ / ₈ " [206 mm]	20RD

ENGINEERING DATA

Model No.	CFM [L/s]	Static Pressure	Throw Feet	Neck Vel.	Jet Vel.	Noise Level
RXRN-FA65	2600 [1227]	.17	24-29	669	669	20
	2800 [1321]	.20	25-30	720	720	25
	3000 [1416]	.25	27-33	772	772	25
	3200 [1510]	.31	28-35	823	823	25
	3400 [1605]	.37	30-37	874	874	30

[] Designates Metric Conversions

FLUSH MOUNT CONCENTRIC DIFFUSER

RXRN-FA75 (6 Ton [21.1 kW] Model)

For Use With Duct Adapter (RXMC)

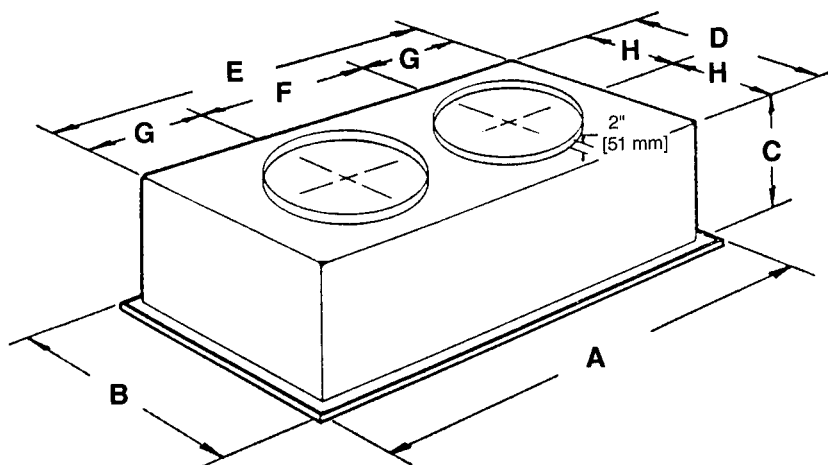

DIMENSIONAL DATA

Model No.	A	B	C	D	E	F	G	H	Duct Size
RXRN-FA75	47 ⁵ / ₈ " [1210 mm]	29 ⁵ / ₈ " [752 mm]	16 ⁵ / ₈ " [422 mm]	27" [686 mm]	45" [1143 mm]	22 ¹ / ₂ " [572 mm]	11 ¹ / ₄ " [286 mm]	13 ¹ / ₂ " [343 mm]	20RD

ENGINEERING DATA

Model No.	CFM [L/s]	Static Pressure	Throw Feet	Neck Vel.	Jet Vel.	Noise Level
RXRN-FA75	2600 [1227]	.17	19-24	663	1294	30
	2800 [1321]	.20	20-28	714	1393	35
	3000 [1416]	.25	21-29	765	1492	35
	3200 [1510]	.31	22-29	816	1592	40
	3400 [1605]	.37	22-30	867	1692	40

[] Designates Metric Conversions

ROOFCURBS (Full Perimeter)

- Rheem's new roofcurb design can be utilized on 3 through 7.5 ton [21.1 kW] models.
- Two available heights (14" [356 mm] and 24" [610 mm]) for ALL models.
- Quick assembly corners for simple and fast assembly.
- Opening provided in bottom pan to match the "Thru the Curb" electrical connection opening provided on the unit base pan.
- 2" [51 mm] x 4" [102 mm] Nailer provided.
- Insulating panels provided.
- Sealing gasket (28" [711 mm]) provided with Roofcurb.
- Packaged for easy field assembly.

Roofcurb Model	Height of Curb
RXKG-CAD14	14" [356 mm]
RXKG-CAD24	24" [610 mm]

[] Designates Metric Conversions

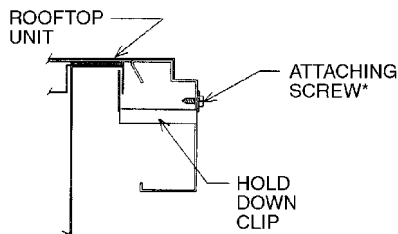
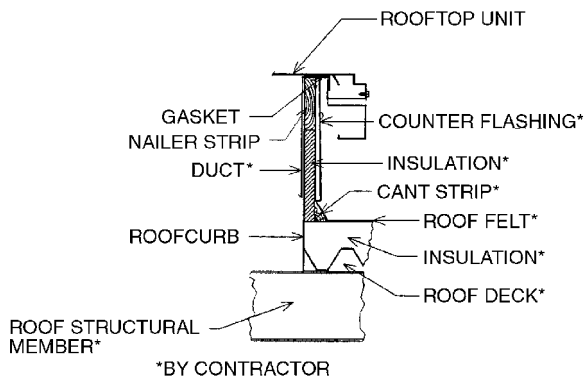

TYPICAL INSTALLATION

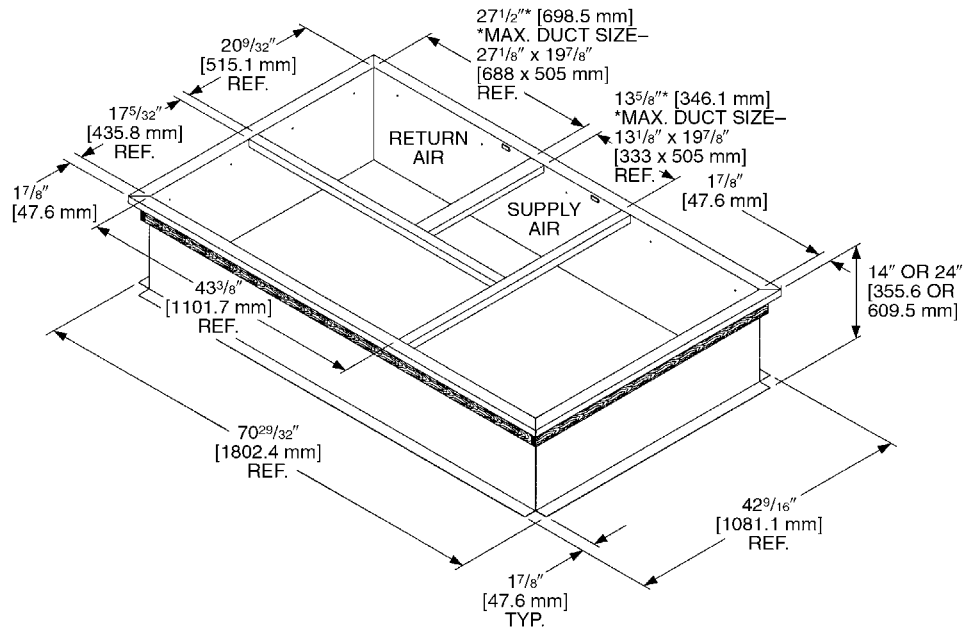
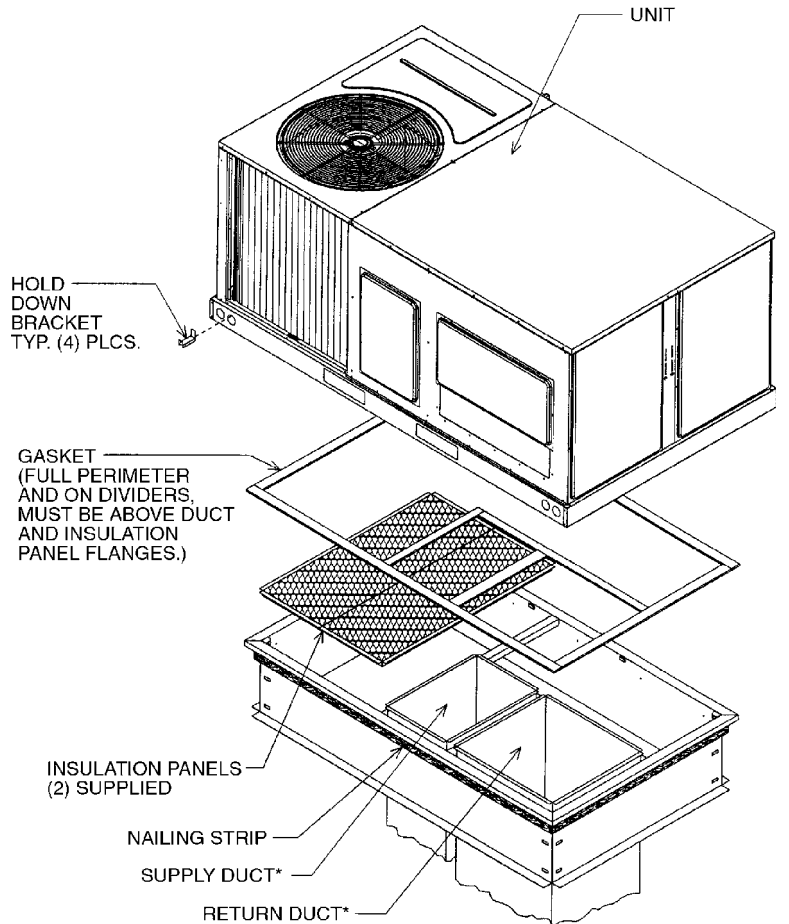

GUIDE SPECIFICATIONS – RKKK-B073/RKKK-C073

You may copy this document directly into your building specification. This specification is written to comply with the 2004 version of the “master format” as published by the Construction Specification Institute. www.csinet.org.

GAS HEAT PACKAGED ROOFTOP

HVAC Guide Specifications

Size Range: 6 Nominal Tons

Section	Description
---------	-------------

23 06 80	Schedules for Decentralized HVAC Equipment
-----------------	---

23 06 80.13	Decentralized Unitary HVAC Equipment Schedule
--------------------	--

23 06 80.13.A.	Rooftop unit schedule
----------------	-----------------------

1. Schedule is per the project specification requirements.

23 07 16	HVAC Equipment Insulation
-----------------	----------------------------------

23 07 16.13	Decentralized, Rooftop Units:
-------------	-------------------------------

1. Interior cabinet surfaces shall be insulated with a minimum 3/4-in. thick, minimum 1-1/2 lb density, flexible fiberglass insulation bonded with a phenolic binder, with aluminum foil facing on the air side.
2. Insulation and adhesive shall meet NFPA 90A requirements for flame spread and smoke generation.

23 09 13	Instrumentation and Control Devices for HVAC
-----------------	---

23 09 13.23	Sensors and Transmitters:
--------------------	----------------------------------

23 09 13.23.A.	Thermostats
----------------	-------------

1. Thermostat must
 - a. have capability to energize 2 different stages of cooling, and 1 stage of heating.
 - b. must include capability for occupancy scheduling.

23 09 23	Direct-digital Control system for HVAC (RKKK-C073 only)
-----------------	--

23 09 23.13	Decentralized, Rooftop Units:
--------------------	--------------------------------------

23 09 23.13.A.	RTU-C controller
-----------------------	-------------------------

1. Shall be ASHRAE 62-2001 compliant.
2. Shall accept 18-32VAC input power.
3. Shall have an operating temperature range from -40°F (-40°C) to 158°F (70°C), 10% - 95% RH (non-condensing).
4. Controller shall accept the following inputs: space temperature, setpoint adjustment, outdoor air temperature, indoor air quality, outdoor air enthalpy, fire shutdown, return air enthalpy, fan status, remote time clock/door switch.
5. Shall accept a CO₂ sensor in the conditioned space, and be Demand Control Ventilation (DCV) ready.
6. Shall provide the following outputs: Economizer, fan, cooling stage 1, cooling stage 2, heat stage 1, heat stage 2, heat stage 3/ exhaust/ occupied.
7. Unit shall provide surge protection for the controller through a circuit breaker.
8. Shall have a field installed communication card allowing the unit to be Internet capable, and communicate at a Baud rate of 19.2K or faster.
9. Shall have an LED display independently showing the status of activity on the communication bus, and processor operation.
10. Shall have either a field installed BACnet® plug-in communication card which includes an EIA-485 protocol communication port, or a field installed LonWorks™ plug-in communications card.
11. Software upgrades will be accomplished by local download. Software upgrades through chip replacements are not allowed.
12. Shall be shock resistant in all planes to 5G peak, 11ms during operation, and 100G peak, 11ms during storage.
13. Shall be vibration resistant in all planes to 1.5G @ 20-300 Hz.
14. Shall support a bus length of 4000 ft max, 60 devices per 1000 ft section, and 1 RS-485 repeater per 1000 ft sections.

23 09 23.13.B.	Open protocol, direct digital controller:
-----------------------	--

1. Shall be ASHRAE 62-2001 compliant.
2. Shall accept 18-30VAC, 50-60Hz, and consume 15VA or less power.
3. Shall have an operating temperature range from -40°F (-40°C) to 130°F (54°C), 10% - 90% RH (non-condensing).
4. Shall have either a field installed BACnet® plug-in communication card which includes an EIA-485 protocol communication port, or a field installed LonWorks™ plug-in communications card.
5. The BACnet® plug in communication card shall include built-in protocol for BACNET (MS/TP and PTP modes).
6. The LonWorks™ plug in communication card shall include the Echelon processor required for all Lon applications.
7. Shall allow access of up to 62 network variables (SNVT). Shall be compatible with all open controllers.
8. Baud rate Controller shall be selectable through the EIA-485 protocol communication port.
9. Shall have an LED display independently showing the status of serial communication, running, errors, power, all digital outputs, and all analog inputs.
10. Shall accept the following inputs: space temperature, setpoint adjustment, outdoor air temperature, indoor air quality, outdoor air enthalpy, compressor lock-out, fire shutdown, enthalpy switch, and fan status/filter status/ humidity/ remote occupancy.
11. Shall provide the following outputs: economizer, fan, cooling stage 1, cooling stage 2, heat stage 1, heat stage 2, heat stage 3/ exhaust.
12. Software upgrades will be accomplished by either local or remote download. No software upgrades through chip replacements are allowed.

23 09 33 Electric and Electronic Control System for HVAC**23 09 33.13 Decentralized, Rooftop Units:**

23 09 33.13.A. General:

1. Shall be complete with self-contained low-voltage control circuit protected by a replaceable fuse on the 24-v transformer side. Transformer size is 40VA.
2. Shall utilize color-coded wiring.
3. Unit shall provide a minimum of one 10-pin screw terminal connection board for connection of control wiring.
4. Shall include a central control terminal board to conveniently and safely provide connection points for vital control functions such as: smoke detectors, phase monitor, economizer, thermostat, DDC control options, loss of charge, freeze sensor, high pressure switches.
5. The heat exchanger shall be controlled by an integrated furnace controller (IFC) microprocessor. See heat exchanger section of this specification.

23 09 33.13.B. Safeties:

1. Compressor over-temperature, over current.
2. Loss of charge switch.
 - a. Units with 2 compressors shall have different colored wires for the circuit 1 and circuit 2 low and high pressure switches.
 - b. Loss of charge switch shall use different color wire than the high pressure switch. The purpose is to assist the installer and service technician to correctly wire and or troubleshoot the rooftop unit.
 - c. Loss of charge switch shall have a different sized connector than the high pressure switch. They shall physically prevent the cross-wiring of the safety switches between the high and low pressure side of the system.
3. High-pressure switch.
 - a. Units with 2 compressors shall have different colored wires for the circuit 1 and circuit 2 low and high pressure switches.
 - b. High pressure switch shall use different color wire than the low pressure switch. The purpose is to assist the installer and service person to correctly wire and or troubleshoot the rooftop unit.
 - c. High pressure switch shall have a different sized connector than the loss of charge switch. They shall physically prevent the cross-wiring of the safety switches between the high and low pressure side of the system.
4. Automatic reset, motor thermal overload protector.
5. Freeze protection sensor, evaporator coil.
6. Heating section shall be provided with the following minimum protections.
 - a. High-temperature limit switches.
 - b. Induced draft motor pressure switch.
 - c. Flame rollout switch.
 - d. Flame proving controls.

23 09 93 Sequence of Operations for HVAC Controls**23 09 93.13 Decentralized, Rooftop Units:**

23 09 93.13 INSERT SEQUENCE OF OPERATION

23 40 13 Panel Air Filters**23 40 13.13 Decentralized, Rooftop Units:**

23 40 13.13.A. Standard filter section

1. Shall consist of factory-installed, low velocity, throwaway 1-in. thick fiberglass filters of commercially available sizes.
2. Unit shall use only one filter size. Multiple sizes are not acceptable.
3. Filter face velocity shall not exceed 365 fpm at nominal airflows.
4. Filters shall be accessible through an access panel as described in the unit cabinet section of the specification (23 81 19.13.H).
5. Filter rack will also accept 2-in thick fiberglass filters of commercially available sizes by removal of a tab.

23 81 19 Self-Contained Air Conditioners**23 81 19.13 Small-Capacity Self-Contained Air Conditioners**

23 81 19.13.A. General

1. Outdoor, rooftop mounted, electrically controlled, heating and cooling unit utilizing a hermetic scroll compressor for cooling duty and gas combustion for heating duty.
2. Factory assembled, single-piece heating and cooling rooftop unit. Contained within the unit enclosure shall be all factory wiring, piping, controls, and special features required prior to field start-up.
3. Unit shall use environmentally safe, R-410A refrigerant.
4. Unit shall be installed in accordance with the manufacturer's instructions.
5. Unit must be selected and installed in compliance with local, state, and federal codes.

23 81 19.13.B. Quality Assurance

1. Unit meets ASHRAE 90.1-2010 minimum efficiency requirements.
2. Unit shall be rated in accordance with AHRI Standards 210/240.
3. Unit shall be designed to conform to ASHRAE 15-2010.
4. Unit shall be UL-tested and certified in accordance with ANSI Z21.47 Standards and UL-listed and certified under Canadian standards as a total package for safety requirements.
5. Insulation and adhesive shall meet NFPA 90A requirements for flame spread and smoke generation.
6. Unit casing shall be capable of withstanding 500-hour salt spray exposure per ASTM B117 (scribed specimen).

7. Unit casing shall be capable of withstanding Federal Test Method Standard No. 141 (Method 6061) 5000-hour salt spray.
 8. Unit shall be designed in accordance with ISO 9001:2008, and shall be manufactured in a facility registered by ISO 9001:2008.
 9. Roof curb shall be designed to conform to NRCA Standards.
 10. Unit shall be subjected to a completely automated run test on the assembly line. The data for each unit will be stored at the factory, and must be available upon request.
 11. Unit shall be designed in accordance with UL Standard 1995, including tested to withstand rain.
 12. Unit shall be constructed to prevent intrusion of snow and tested to prevent snow intrusion into the control box up to 40 mph.
- 23 81 19.13.C. Delivery, Storage, and Handling
1. Unit shall be stored and handled per manufacturer's recommendations.
 2. Lifted by crane requires either shipping top panel or spreader bars.
 3. Unit shall only be stored or positioned in the upright position.
- 23 81 19.13.E. Project Conditions
1. As specified in the contract.
- 23 81 19.13.F. Operating Characteristics
1. Unit shall be capable of starting and running at 115°F (46°C) ambient outdoor temperature, meeting maximum load criteria of AHRI Standard 210/240 at ± 10% voltage.
 2. Compressor with standard controls shall be capable of operation down to 40°F (4°C), ambient outdoor temperatures. Accessory low ambient kit is necessary if mechanically cooling at ambient temperatures below 40°F (4°C).
 3. Unit shall discharge supply air vertically or horizontally as shown on contract drawings.
 4. Unit shall be factory configured for vertical supply & return configurations.
 5. Unit shall be field convertible from vertical to horizontal configuration.
- 23 81 19.13.G. Electrical Requirements
1. Main power supply voltage, phase, and frequency must match those required by the manufacturer.
- 23 81 19.13.H. Unit Cabinet
1. Unit cabinet shall be constructed of galvanized steel, and shall be bonderized and coated with a Pre-paint baked enamel finish on all externally exposed surfaces.
 2. Unit cabinet exterior paint shall be: film thickness, (dry) 0.003 inches minimum, gloss (per ASTM D523, 60°F / 16°C): 60, Hardness: H-2H Pencil hardness.
 3. Evaporator fan compartment interior cabinet insulation shall conform to AHRI Standards 210/240 minimum exterior sweat criteria. Interior surfaces shall be insulated with a minimum 3/4-in. thick, 1 lb. density, flexible fiberglass insulation, aluminum foil-face coated on the air side.
 4. Base of unit shall have locations for thru-the-base gas and electrical connections (factory installed or field installed), standard.
 5. Base Rail
 - a. Unit shall have base rails on all sides.
 - b. Holes shall be provided in the base rails for rigging shackles to facilitate maneuvering and overhead rigging.
 - c. Holes shall be provided in the base rail for moving the rooftop by fork truck.
 - d. Base rail shall be a minimum of 14 gauge thickness.
 6. Condensate pan and connections:
 - a. Shall be a condensate drain pan made of a non-corrosive material. Unit must be installed at a slight angle to allow for complete drainage.
 - b. Shall comply with ASHRAE Standard 62.
 - c. Shall use a 3/4" x 14 NPT drain connection through the side of the drain pan. Connection shall be made per manufacturer's recommendations.
 7. Electrical Connections
 - a. All unit power wiring shall enter unit cabinet at a single, factory-prepared, knockout location.
 - b. Thru-the-base capability
 - i. Standard unit shall have a thru-the-base electrical location(s) using a raised, embossed portion of the unit basepan.
 - ii. No basepan penetration, other than those authorized by the manufacturer, is permitted.
 8. Component access panels (standard)
 - a. Cabinet panels shall be easily removable for servicing.
 9. Component access panels (Optional)
 - a. Panels covering control box, indoor blower assembly, indoor blower motor, and air filters shall have metal hinges and 1/4 turn latches.
 10. Gas Connections:
 - a. All gas piping connecting to unit gas valve shall enter the unit cabinet at a single location on side of unit (horizontal plane).
 - b. Thru-the-base capability
 - i. Standard unit shall have a thru-the-base gas-line location using a raised, embossed portion of the unit basepan.
 - ii. No basepan penetration, other than those authorized by the manufacturer, is permitted.
- 23 81 19.13.I. Gas Heat
1. General
 - a. Heat exchanger shall be an induced draft design. Positive pressure heat exchanger designs shall not be allowed.
 - b. Shall incorporate a direct-spark ignition system and redundant main gas valve.

- c. Heat exchanger design shall allow combustion process condensate to gravity drain; maintenance to drain the gas heat exchanger shall not be required.
 - d. Gas supply pressure at the inlet to the rooftop unit gas valve must match that required by the manufacturer.
 - 2. The heat exchanger shall be controlled by an integrated furnace controller (IFC) microprocessor.
 - a. IFC board shall notify users of fault using an LED (light-emitting diode).
 - 3. Standard Heat Exchanger construction
 - a. Heat exchanger shall be of the tubular-section type constructed of a minimum of 20-gauge aluminum coated steel for corrosion resistance.
 - b. Burners shall be of the in-shot type constructed of aluminum-coated steel.
 - c. Burners shall incorporate orifices for rated heat output up to 2000 ft (610m) elevation. Additional accessory kits may be required for applications above 2000 ft (610m) elevation, depending on local gas supply conditions.
 - 4. Optional Stainless Steel Heat Exchanger construction
 - a. Use energy saving, direct-spark ignition system.
 - b. Use a redundant main gas valve.
 - c. Burners shall be of the in-shot type constructed of aluminum-coated steel.
 - d. All gas piping shall enter the unit cabinet at a single location on side of unit (horizontal plane).
 - e. The optional stainless steel heat exchanger shall be of the tubular-section type, constructed of a minimum of 20-gauge type 409 stainless steel.
 - f. Type 409 stainless steel shall be used in heat exchanger tubes and vestibule plate.
 - g. Complete stainless steel heat exchanger allows for greater application flexibility.
 - 5. Induced draft combustion motors and blowers
 - a. Shall be a direct-drive, single inlet, forward-curved centrifugal type.
 - b. Shall be made from steel with a corrosion-resistant finish.
 - c. Shall have permanently lubricated sealed bearings.
 - d. Shall have inherent thermal overload protection.
 - e. Shall have an automatic reset feature.
- 23 81 19.13.J. Coils
- 1. Aluminum MicroChannel evaporator and condenser coils on all models.
 - a. Shall have aluminum lanced fins thermally bonded to aluminum multi-port flat tube design (microchannel) tubes. Coils shall be furnace brazed and contain epoxy lined shrink wrap on all aluminum to copper connections.
 - b. Shall be leak tested using helium mass spectrometry. The leak rate shall not exceed 6.5×10^{-5} sccs of 100% helium at 200 psig, and qualified to UL 1995 burst test at 1950 psig.
 - c. Evaporator coil includes internal distributor plate to prevent mal-distribution of two-phase refrigerant.
- 23 81 19.13.K. Refrigerant Components
- 1. Refrigerant circuit shall include the following control, safety, and maintenance features:
 - a. Thermal Expansion Valves (TXV).
 - b. Refrigerant filter drier.
 - c. Service gauge connections on suction and liquid lines.
 - d. External pressure gauge ports access shall be located in front exterior of cabinet.
 - 2. Compressors
 - a. Unit shall use one fully hermetic, scroll compressor.
 - b. Compressor motors shall be cooled by refrigerant gas passing through motor windings.
 - c. Compressors shall be internally protected from high discharge temperature conditions.
 - d. Compressors shall be protected from an over-temperature and over-ampereage conditions by an internal, motor overload device.
 - e. Compressor shall be factory mounted on rubber grommets.
 - f. Compressor motors shall have internal line break thermal and current overload protection along with high pressure differential protection.
 - g. Crankcase heaters shall not be required for normal operating range.
- 23 81 19.13.L. Filter Section
- 1. Filters access is specified in the unit cabinet section of this specification.
 - 2. Shall consist of factory-installed, low velocity, throw-away 1-in. thick fiberglass filters.
 - 3. Filter face velocity shall not exceed 365 fpm at nominal airflows.
 - 4. Filters shall be standard, commercially available sizes.
 - 5. Only one size filter per unit is allowed.
 - 6. Filter rack will also accept 2-in thick fiberglass filters of commercially available sizes by removal of a tab.
- 23 81 19.13.M. Evaporator Fan and Motor
- 1. Evaporator fan motor:
 - a. Shall have permanently lubricated bearings.
 - b. Shall have inherent automatic-reset thermal overload protection.
 - c. Shall have a maximum continuous bhp rating for continuous duty operation; no safety factors above that rating shall be required.

2. Belt-driven Evaporator Fan:
 - a. Belt drive shall include an adjustable-pitch motor pulley.
 - b. Shall use sealed, permanently lubricated ball-bearing type.
 - c. Blower fan shall be double-inlet type with forward-curved blades.
 - d. Shall be constructed from steel with a corrosion resistant finish and dynamically balanced.
 3. High-Static Belt-driven Evaporator Fan Motor(s) and Drive(s):
 - a. High-static motor(s) and drive(s) shall be factory-installed to provide additional performance range.
- 23 81 19.13.N. Condenser Fans and Motors
1. Condenser fan motors:
 - a. Shall be a totally enclosed motor.
 - b. Shall use permanently lubricated bearings.
 - c. Shall have inherent thermal overload protection with an automatic reset feature.
 - d. Shall use a shaft-down design. Shaft-up designs including those with “rain-slinger devices” shall not be allowed.
 2. Condenser Fans shall:
 - a. Shall be a direct-driven propeller type fan
 - b. Shall have aluminum blades riveted to corrosion-resistant steel spiders and shall be dynamically balanced.
- 23 81 19.13.O. Special Features
1. Integrated Economizers:
 - a. Integrated, gear-driven parallel modulating blade design type capable of simultaneous economizer and compressor operation.
 - b. Module designed for vertical or horizontal return configurations. Vertical return configuration shall be available as a factory installed option.
 - c. Damper blades shall be galvanized steel with metal gears. Plastic or composite blades on intake or return shall not be acceptable.
 - d. Shall include all hardware and controls to provide free cooling with outdoor air when temperature and/or humidity are below setpoints.
 - e. Shall be equipped with gear driven dampers for both the outdoor ventilation air and the return air for positive air stream control.
 - f. Shall be capable of introducing up to 100% outdoor air.
 - g. Shall be equipped with a barometric relief damper capable of relieving up to 100% return air. The barometric relief damper shall include seals, hardware and hoods to relieve building pressure. Damper shall gravity close upon unit shut down.
 - h. Shall be designed to close damper(s) during loss-of-power situations with spring return built into motor.
 - i. An outdoor single-enthalpy sensor shall be provided as standard. Outdoor air enthalpy set point shall be adjustable and shall range from the enthalpy equivalent of 63°F @ 50% rh to 73°F @ 50% rh. Additional sensor options shall be available as accessories.
 - j. The economizer controller shall also provide control of an accessory power exhaust unit function. Factory set at 70%, with a range of 0% to 100%.
 - k. The economizer shall maintain minimum airflow into the building during occupied period and provide design ventilation rate for full occupancy.
 - l. Economizer controller shall accept a 0-10Vdc CO₂ sensor input over a CO₂ range of 0-2000 ppm for IAQ/DCV control. In this mode, dampers shall modulate the outdoor-air damper to provide ventilation based on the sensor input.
 - m. Actuator shall be direct coupled to economizer gear. No linkage arms or control rods shall be acceptable.
 - n. Economizer controller shall provide indications when in free cooling mode, in the DCV mode, or the exhaust fan contact is closed.
 - o. Ultra Low Leak Dampers shall meet California Title 24 requirements.
 - p. Economizer controller shall meet California Title 24 FDD (Fault Detection and Diagnostics) requirement.
 2. Two-Position Damper
 - a. Damper shall be a Two-Position Damper. Damper travel shall be from the full closed position to the field adjustable %-open setpoint.
 - b. Damper shall include adjustable damper travel from 25% to 100% (full open).
 - c. Damper shall include single or dual blade, gear driven damper and actuator motor.
 - d. Actuator shall be direct coupled to economizer gear. No linkage arms or control rods shall be acceptable.
 - e. Damper will admit up to 100% outdoor air for applicable rooftop units.
 - f. Damper shall close upon indoor (evaporator) fan shutoff and/or loss of power.
 - g. The damper actuator shall plug into the rooftop unit’s wiring harness plug. No hard wiring shall be required.
 - h. Outside air hood shall include aluminum water entrainment filter.
 3. Manual damper
 - a. Manual damper package shall consist of damper, air inlet screen, and rain hood which can be preset to admit up to 50% outdoor air for year round ventilation.
 4. Head Pressure Control Package
 - a. Controller shall control coil head pressure by condenser-fan cycling.
 5. Condenser Coil Hail Guard Assembly
 - a. Shall protect against damage from hail.
 - b. Shall be louvered design.

6. Thru-the-Base Connectors:
 - a. Kits shall provide connectors to permit gas and electrical connections to be brought to the unit through the unit basepan.
7. Propeller Power Exhaust:
 - a. Power exhaust shall be used in conjunction with an integrated economizer.
 - b. Independent modules for vertical or horizontal return configurations shall be available.
 - c. Horizontal power exhaust shall be mounted in return ductwork.
 - d. Power exhaust shall be controlled by economizer controller operation. Exhaust fans shall be energized when dampers open past the 0-100% adjustable setpoint on the economizer control.
8. Roof Curbs (Vertical):
 - a. Full perimeter roof curb with exhaust capability providing separate airstreams for energy recovery from the exhaust air without supply air contamination.
 - b. Formed galvanized steel with wood nailer strip and shall be capable of supporting entire unit weight.
 - c. Permits installation and securing of ductwork to curb prior to mounting unit on the curb.
9. Outdoor Air Enthalpy Sensor:
 - a. The outdoor air enthalpy sensor shall be used to provide single enthalpy control. When used in conjunction with a return air enthalpy sensor, the unit will provide differential enthalpy control. The sensor allows the unit to determine if outside air is suitable for free cooling.
10. Return Air Enthalpy Sensor:
 - a. The return air enthalpy sensor shall be used in conjunction with an outdoor air enthalpy sensor to provide differential enthalpy control.
11. Indoor Air Quality (CO₂) Sensor:
 - a. Shall be able to provide demand ventilation indoor air quality (IAQ) control.
 - b. The IAQ sensor shall be available in wall mount with LED display. The set point shall have adjustment capability.
 - c. The sensor shall provide a 0-10Vdc output for a CO₂ input range of 0-2000 ppm.
12. Smoke detectors:
 - a. Shall be a Four-Wire Controller and Detector.
 - b. Shall be environmental compensated with differential sensing for reliable, stable, and drift-free sensitivity.
 - c. Shall use magnet-activated test/reset sensor switches.
 - d. Shall have a recessed momentary switch for testing and resetting the detector.
 - e. Controller shall include:
 - i. One set of normally open alarm initiation contacts for connection to an initiating device circuit on a fire alarm control panel
 - ii. Two Form-C auxiliary alarm relays for interface with rooftop unit or other equipment.
 - iii. One Form-C supervision (trouble) relay to control the operation of the Trouble LED on a remote test/reset station.
 - iv. Capable of direct connection to two individual detector modules.
 - v. Can be wired to up to 14 other duct smoke detectors for multiple fan shutdown applications.
13. Non-Powered convenience outlet.
 - a. Outlet shall be powered from a separate 115-120v power source.
 - b. A transformer shall not be included.
 - c. Outlet shall be field-installed and internally mounted with easily accessible 115-v female receptacle.
 - d. Outlet shall include 15 amp GFI receptacle.
 - e. Outlet shall be accessible from outside the unit.
 - f. Outlet shall have a wet location, while in use cover
14. Unit-Mounted, Non-Fused Disconnect Switch:
 - a. Switch shall be factory-installed, internally mounted.
 - b. National Electric Code (NEC) and UL approved non-fused switch shall provide unit power shutoff.
 - c. Shall be accessible from outside the unit.
 - d. Shall provide local shutdown and lockout capability.
15. Universal Gas Conversion Kit:
 - a. Package shall contain all the necessary hardware and instructions to convert a standard natural gas unit to operate from 2000-7000 ft (610 to 2134m) elevation with natural gas or from 0-7000 ft (90-2134m) elevation with liquefied propane.
16. Liquid Propane (LP) Conversion Kit
 - a. Package shall contain all the necessary hardware and instructions to convert a standard natural gas unit for use with liquefied propane, up to 2000 ft (610m) elevation.
17. Flue Discharge Deflector:
 - a. Flue discharge deflector shall direct unit exhaust vertically instead of horizontally.
 - b. Deflector shall be defined as a "natural draft" device by the National Fuel and Gas (NFG) code.
18. Fan/Filter Status Switch:
 - a. Switch shall provide status of indoor evaporator fan (ON/OFF) or filter (CLEAN/DIRTY).
 - b. Status shall be displayed either over communication bus (when used with direct digital controls) or through the controller LCD display inside the unit control box.

BEFORE PURCHASING THIS APPLIANCE, READ IMPORTANT ENERGY COST AND EFFICIENCY INFORMATION AVAILABLE FROM YOUR RETAILER.

GENERAL TERMS OF LIMITED WARRANTY*

Rheem will furnish a replacement for any part of this product which fails in normal use and service within the applicable periods stated, in accordance with the terms of the limited warranty.

Heat ExchangerTen (10) Years

***For complete details of the Limited and Conditional Warranties, including applicable terms and conditions, contact your local contractor or the Manufacturer for a copy of the product warranty certificate.**

Compressor

3 Phase, Commercial ApplicationsFive (5) Years

Parts

3 Phase, Commercial ApplicationsOne (1) Year

Factory Standard Heat Exchanger

3 Phase, Commercial ApplicationsTen (10) Years



The new degree of comfort.™

In keeping with its policy of continuous progress and product improvement, Rheem reserves the right to make changes without notice.

Rheem Heating, Cooling & Water Heating • P.O. Box 17010
Fort Smith, Arkansas 72917 • www.rheem.com

Rheem Canada Ltd./Ltée • 125 Edgeware Road, Unit 1
Brampton, Ontario • L6Y 0P5



INTEGRATED AIR & WATER