



The new degree of comfort.™

SUBMITTAL COVER SHEET

PROJECT NAME _____

LOCATION _____

ARCHITECT _____

ENGINEER _____

CONTRACTOR _____

SUBMITTED BY _____ DATE _____

UNIT SUMMARY

Quantity						
Unit Designation						
Model No.						
Total Cooling						
Sensible Cooling						
Air Ent. Evaporator						
Air Lvg. Evaporator						
Heating Input						
Heating Output						
CFM/ESP						
EER/SEER						
Electrical						
Minimum Ampacity						
Min.-Max. Breaker						
Net Unit Weight						
Accessory						
Catalog Form Number						

ACCESSORIES:

NOTES:



Endeavor™ Line *Classic*® Series iM Air Conditioners



RA14AZ

Cooling Efficiency up to: 15.2 SEER2/12 EER2

Nominal Sizes: 1½ to 5 Ton [5.28 to 17.6 kW]

Cooling Capacities: 17.1 to 55.5 kBTU [5.0 to 16.3 kW]

Unit Dimensions

MODEL NO.	OPERATING						SHIPPING					
	H (Height)		L (Length)		W (Width)		H (Height)		L (Length)		W (Width)	
	INCHES	mm	INCHES	mm	INCHES	mm	INCHES	mm	INCHES	mm	INCHES	mm
RA14AZ18	25.00	635	29.75	756	29.75	756	26.50	673	32.38	822	32.38	822
RA14AZ24	25.00	635	33.75	857	33.75	857	26.50	673	36.38	924	36.38	924
RA14AZ30	27.00	686	33.75	857	33.75	857	28.50	724	36.38	924	36.38	924
RA14AZ36	31.00	787	33.75	857	33.75	857	32.50	826	36.38	924	36.38	924
RA14AZ42	35.00	889	33.75	857	33.75	857	36.50	927	36.38	924	36.38	924
RA14AZ48	35.00	889	33.75	857	33.75	857	36.50	927	36.38	924	36.38	924
RA14AZ60	51.00	1295	35.75	908	35.75	908	52.50	1334	38.38	975	38.38	975

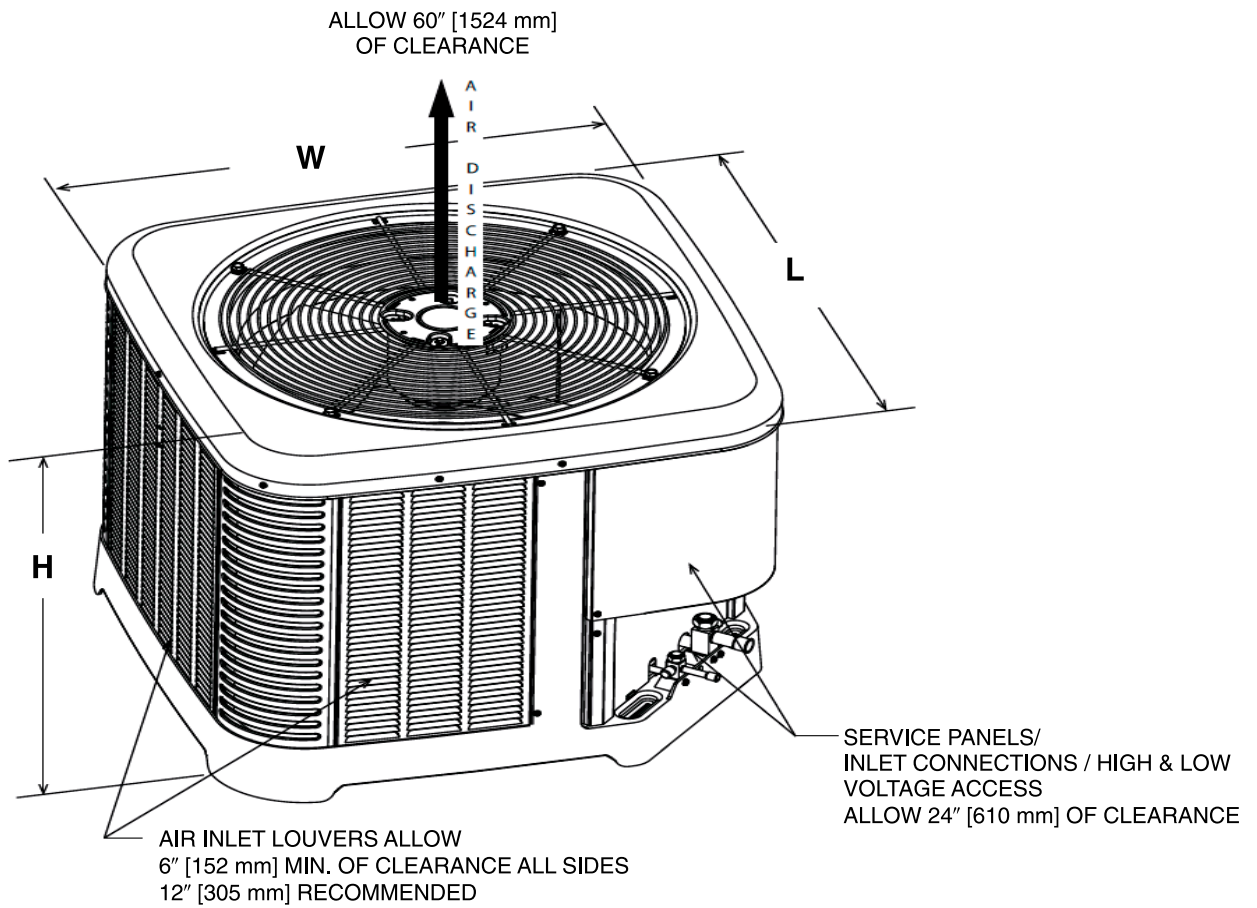

[] Designates Metric Conversions

ST-A1226-02-00