

# INSTALLATION INSTRUCTIONS

## R410A/60HZ CONDENSING UNITS

\*AGN – SERIES

\*AHM – SERIES

## R410A/50HZ CONDENSING UNITS

\*AGL – SERIES

\*AGN – SERIES

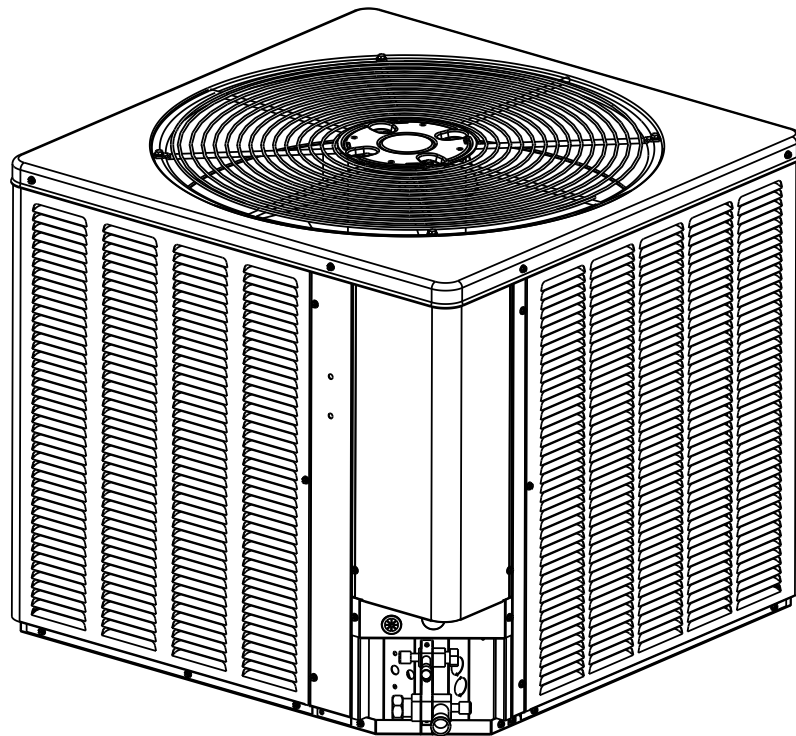

\*S or V

NOTE: Appearance of unit may vary.



**RECOGNIZE THIS SYMBOL AS AN INDICATION OF IMPORTANT SAFETY INFORMATION!**

### **▲ WARNING**

THESE INSTRUCTIONS ARE INTENDED AS AN AID TO QUALIFIED, LICENSED SERVICE PERSONNEL FOR PROPER INSTALLATION, ADJUSTMENT AND OPERATION OF THIS UNIT. READ THESE INSTRUCTIONS THOROUGHLY BEFORE ATTEMPTING INSTALLATION OR OPERATION. FAILURE TO FOLLOW THESE INSTRUCTIONS MAY RESULT IN IMPROPER INSTALLATION, ADJUSTMENT, SERVICE OR MAINTENANCE POSSIBLY RESULTING IN FIRE, ELECTRICAL SHOCK, PROPERTY DAMAGE, PERSONAL INJURY OR DEATH.



**DO NOT DESTROY THIS MANUAL**

**PLEASE READ CAREFULLY AND KEEP IN A SAFE PLACE FOR FUTURE REFERENCE BY A SERVICEMAN**



# TABLE OF CONTENTS

<b>1.0</b>	<b>SAFETY INFORMATION</b>	<b>3</b>
<b>2.0</b>	<b>GENERAL</b>	<b>4</b>
2.1	Checking Product Received	4
2.2	Application	4
2.3	Dimensions	5
2.4	Clearances	6
2.5	Electrical and Physical Data	8
<b>3.0</b>	<b>LOCATING UNIT</b>	<b>8</b>
3.1	Corrosive Environment	8
3.2	Condenser Location	8
3.3	Operational Issues	8
3.4	For Condensers With Space Limitations	8
3.5	Customer Satisfaction Issues	9
3.6	Proper Installation	9
3.7	Unit Mounting	9
<b>4.0</b>	<b>REFRIGERANT CONNECTIONS</b>	<b>9</b>
<b>5.0</b>	<b>TOOLS REQUIRED FOR INSTALLING &amp; SERVICING R-410A MODELS</b>	<b>9</b>
5.1	Specifications of R-410A	9
5.2	Quick Reference Guide for R-410A	10
<b>6.0</b>	<b>REPLACEMENT UNITS</b>	<b>10</b>
<b>7.0</b>	<b>INDOOR COIL</b>	<b>11</b>
7.1	Location	11
<b>8.0</b>	<b>SELECTING AND SIZING LINE SETS</b>	<b>11</b>
8.1	Line Sets and Fitting Losses	11
8.2	Liquid Line Selection	12
8.3	Vapor Suction Line Selection	13
8.4	Refrigerant Level Adjustment	13
8.5	Additional Oil Adjustment	14
8.6	Long Line Set Applications	14
8.7	Long Line Set Accessories	14
8.8	Long Line Set Unit Requirements	16
8.9	Long Line Installation Considerations	16
8.10	Summary of Important Notes	20
<b>9.0</b>	<b>INTERCONNECTING TUBING</b>	<b>21</b>
9.1	General Guidelines Line Installation	21
9.2	Line Set Connections - ODU	22
9.3	Line Set Leak Testing	24
<b>10.0</b>	<b>START-UP – CHECKING AIRFLOW</b>	<b>25</b>
<b>11.0</b>	<b>EVACUATION AND LEAK TESTING</b>	<b>25</b>
11.1	Evacuation Procedure	25
11.2	Final Leak Testing	26
<b>12.0</b>	<b>CHECKING REFRIGERANT CHARGE</b>	<b>26</b>
12.1	Charging Units With R-410A Refrigerant	26
12.2	Measurement Device Setup	27
12.3	Charging By Weight	27
12.4	Gross Charging By Pressures	28
12.5	Final Charge By Sub-Cooling	28
12.6	Finishing Up Installation	29
<b>13.0</b>	<b>ELECTRICAL WIRING</b>	<b>29</b>
13.1	Grounding	29
13.2	Power Wiring	29
13.3	Control Wiring	30
<b>14.0</b>	<b>FIELD INSTALLED ACCESSORIES</b>	<b>30</b>
14.1	Compressor Crankcase Heat (CCH)	30
14.2	Time Delay Control (TDC)	31
<b>15.0</b>	<b>SERVICE</b>	<b>31</b>
15.1	Operation	31
15.2	Single-Pole Compressor Contactor (CC)	32
<b>16.0</b>	<b>TROUBLE SHOOTING</b>	<b>33</b>
16.1	Electrical Checks Flow Chart	33
16.2	Mechanical Checks Flow Chart	34
16.3	Superheat Calculation	35
16.4	Subcooling Calculation	35
16.5	General	36
	Troubleshooting Chart	36
<b>17.0</b>	<b>WIRING DIAGRAMS</b>	<b>37</b>
	PSC OD Fan Motor	37
	ECM OD Fan Motor	38
	PSC OD Fan Motor	39

# 1.0 SAFETY INFORMATION

## **WARNING**

THESE INSTRUCTIONS ARE INTENDED AS AN AID TO QUALIFIED LICENSED SERVICE PERSONNEL FOR PROPER INSTALLATION, ADJUSTMENT AND OPERATION OF THIS UNIT. READ THESE INSTRUCTIONS THOROUGHLY BEFORE ATTEMPTING INSTALLATION OR OPERATION. FAILURE TO FOLLOW THESE INSTRUCTIONS MAY RESULT IN IMPROPER INSTALLATION, ADJUSTMENT, SERVICE OR MAINTENANCE POSSIBLY RESULTING IN FIRE, ELECTRICAL SHOCK, PROPERTY DAMAGE, PERSONAL INJURY OR DEATH.

## **WARNING**

THE MANUFACTURER'S WARRANTY DOES NOT COVER ANY DAMAGE OR DEFECT TO THE HEAT PUMP CAUSED BY THE ATTACHMENT OR USE OF ANY COMPONENTS, ACCESSORIES OR DEVICES (OTHER THAN THOSE AUTHORIZED BY THE MANUFACTURER) INTO, ONTO OR IN CONJUNCTION WITH THE HEAT PUMP. YOU SHOULD BE AWARE THAT THE USE OF UNAUTHORIZED COMPONENTS, ACCESSORIES OR DEVICES MAY ADVERSELY AFFECT THE OPERATION OF THE HEAT PUMP AND MAY ALSO ENDANGER LIFE AND PROPERTY. THE MANUFACTURER DISCLAIMS ANY RESPONSIBILITY FOR SUCH LOSS OR INJURY RESULTING FROM THE USE OF SUCH UNAUTHORIZED COMPONENTS, ACCESSORIES OR DEVICES.

## **WARNING**

DISCONNECT ALL POWER TO UNIT BEFORE STARTING MAINTENANCE. FAILURE TO DO SO CAN CAUSE ELECTRICAL SHOCK RESULTING IN SEVERE PERSONAL INJURY OR DEATH.

## **WARNING**

DO NOT USE OXYGEN TO PURGE LINES OR PRESSURIZE SYSTEM FOR LEAK TEST. OXYGEN REACTS VIOLENTLY WITH OIL, WHICH CAN CAUSE AN EXPLOSION RESULTING IN SEVERE PERSONAL INJURY OR DEATH.

## **WARNING**

THE UNIT MUST BE PERMANENTLY GROUNDED. FAILURE TO DO SO CAN CAUSE ELECTRICAL SHOCK RESULTING IN SEVERE PERSONAL INJURY OR DEATH.

## **WARNING**

TURN OFF ELECTRIC POWER AT THE FUSE BOX OR SERVICE PANEL BEFORE MAKING ANY ELECTRICAL CONNECTIONS.

ALSO, THE GROUND CONNECTION MUST BE COMPLETED BEFORE MAKING LINE VOLTAGE CONNECTIONS. FAILURE TO DO SO CAN RESULT IN ELECTRICAL SHOCK, SEVERE PERSONAL INJURY OR DEATH.

## **CAUTION**

The filter drier is located inside the control box. The filter drier must be installed externally in the liquid line or the Warranty will be VOID!

## **CAUTION**

This appliance is not intended for use by persons (including children) with reduced physical, sensory or mental capabilities, or lack of experience and knowledge, unless they have been given supervision or instruction concerning use of the appliance by a person responsible for their safety.

Children should be supervised to ensure that they do not play with this appliance.

## WARNING

THE MANUFACTURER'S WARRANTY DOES NOT COVER ANY DAMAGE OR DEFECT TO THE AIR CONDITIONER CAUSED BY THE ATTACHMENT OR USE OF ANY COMPONENTS, ACCESSORIES OR DEVICES (OTHER THAN THOSE AUTHORIZED BY THE MANUFACTURER) INTO, ONTO OR IN CONJUNCTION WITH THE AIR CONDITIONER. YOU SHOULD BE AWARE THAT THE USE OF UNAUTHORIZED COMPONENTS, ACCESSORIES OR DEVICES MAY ADVERSELY AFFECT THE OPERATION OF THE AIR CONDITIONER AND MAY ALSO ENDANGER LIFE AND PROPERTY. THE MANUFACTURER DISCLAIMS ANY RESPONSIBILITY FOR SUCH LOSS OR INJURY RESULTING FROM THE USE OF SUCH UNAUTHORIZED COMPONENTS, ACCESSORIES OR DEVICES.

## 2.0 GENERAL

The information contained in this manual has been prepared to assist in the proper installation, operation and maintenance of the air conditioning system. Improper installation, or installation not made in accordance with these instructions, can result in unsatisfactory operation and/or dangerous conditions, and can cause the related warranty not to apply.

Read this manual and any instructions packaged with separate equipment required to make up the system prior to installation. Retain this manual for future reference.

To achieve optimum efficiency and capacity, the indoor cooling coils or air handler listed in the condensing unit specification sheet should be used.

**IMPORTANT:** We recommend replacement of any HVAC equipment that has been subjected to flooding in order to avoid any risk of injury or harm.

**IMPORTANT:** Use all available safety precautions during the installation and servicing of any HVAC equipment.

Reference the model nameplate and brand label on the unit for the following product information:

- Model Number
- Serial Number
- Country of Origin
- Rated Voltage and Frequency
- Rated T1 and T3 conditions for:
  - Rated Current
  - Rated Power (kW)
  - Rated Capacity
  - Rated EER

The Estimated Annual Energy Consumption of this product is calculated using the following formula:

Estimated Annual Energy Consumption = Rated Power (kW) at T1 conditions multiplied by 2700 working hours.

### 2.1 CHECKING PRODUCT RECEIVED

Upon receiving unit, inspect it for any shipping damage. Claims for damage, either apparent or concealed, should be filed immediately with the shipping company. Check condensing unit model number, electrical characteristics and accessories to determine if they are correct and match the original order from the local distributor. Check system components (evaporator coil, condensing unit, evaporator blower, etc.) to make sure they are properly matched.

### 2.2 APPLICATION

Before installing any air conditioning equipment, a duct analysis of the structure and a heat gain calculation must be made. A heat gain calculation begins by measuring all external surfaces and openings that gain heat from the surrounding air and quantifying that heat gain. A heat gain calculation also calculates the extra heat load caused by sunlight and by humidity removal.

There are several factors that the installers must consider:

- Outdoor unit location
- System refrigerant charge
- Indoor unit blower speed
- System air balancing
- Proper equipment evacuation
- Indoor unit airflow
- Supply and return air duct design and sizing
- Diffuser and return air grille location and sizing

2.3 (SEE FIGURE 1)

FIGURE 1  
DIMENSIONS

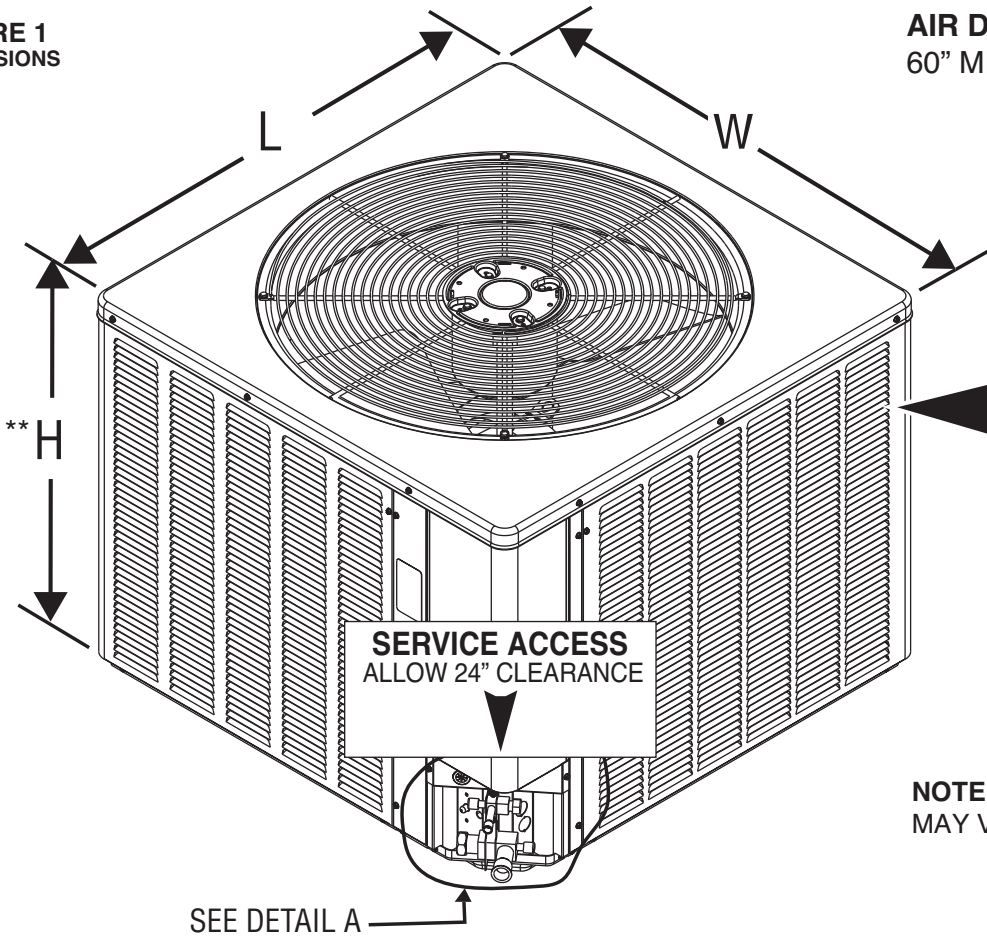

**AIR DISCHARGE:** ALLOW 60" MINIMUM CLEARANCE.

**AIR INLETS**  
(LOUVERED PANELS) ALLOW 12" MINIMUM CLEARANCE FOR SINGLE UNIT APPLICATIONS  
24" MINIMUM CLEARANCE FOR MULTIPLE UNIT APPLICATIONS

**NOTE:** GRILLE APPEARANCE MAY VARY.

SEE DETAIL A

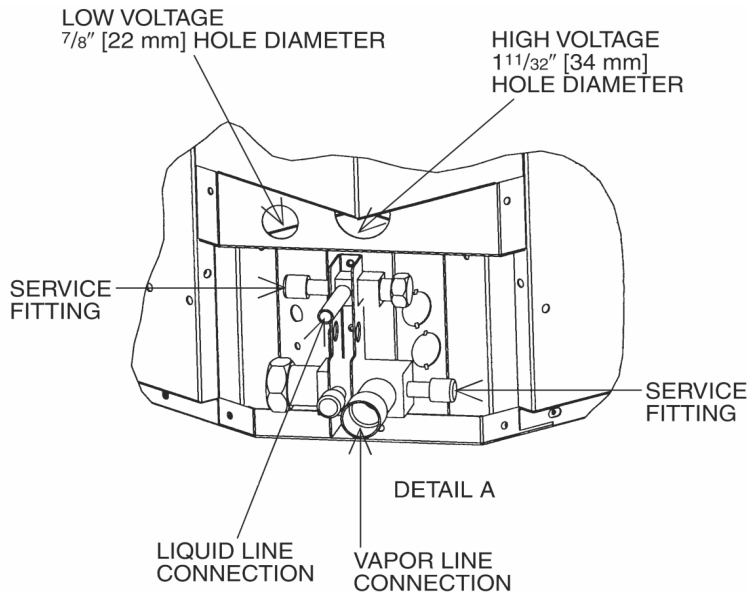

**DIMENSIONAL DATA**

Condenser Series	Model / Size	Height "H" in. [mm]	Length "L" in. [mm]	Width "W" in. [mm]
*AGL	18, 24	24 1/4 [616]	23 5/8 [600]	23 5/8 [600]
*AGN	18, 24	24 1/4 [616]	23 5/8 [600]	23 5/8 [600]
*AGL	30	24 1/4 [616]	23 5/8 [600]	23 5/8 [600]
*AGN	30J, 36J, 42J	24 1/4 [616]	23 5/8 [600]	23 5/8 [600]
*AHM	19, 25	24 1/4 [616]	23 5/8 [600]	23 5/8 [600]
*AGL	36, 42	27 3/8 [710]	31 5/8 [803]	31 5/8 [803]
*AGN	48J	27 3/8 [710]	31 5/8 [803]	31 5/8 [803]
*AHM	30	27 3/8 [710]	31 5/8 [803]	31 5/8 [803]
*AGL	48, 60, 65	35 3/8 [913]	31 5/8 [803]	31 5/8 [803]
*AGN	30T, 36T, 60J	35 3/8 [913]	31 5/8 [803]	31 5/8 [803]
*AHM	36, 42, 48, 49, 56, 60	35 3/8 [913]	31 5/8 [803]	31 5/8 [803]

**NOTE:** "\*\*\*H" dimension includes baserails and/or basepan.

\*S or V

## 2.4 CLEARANCES

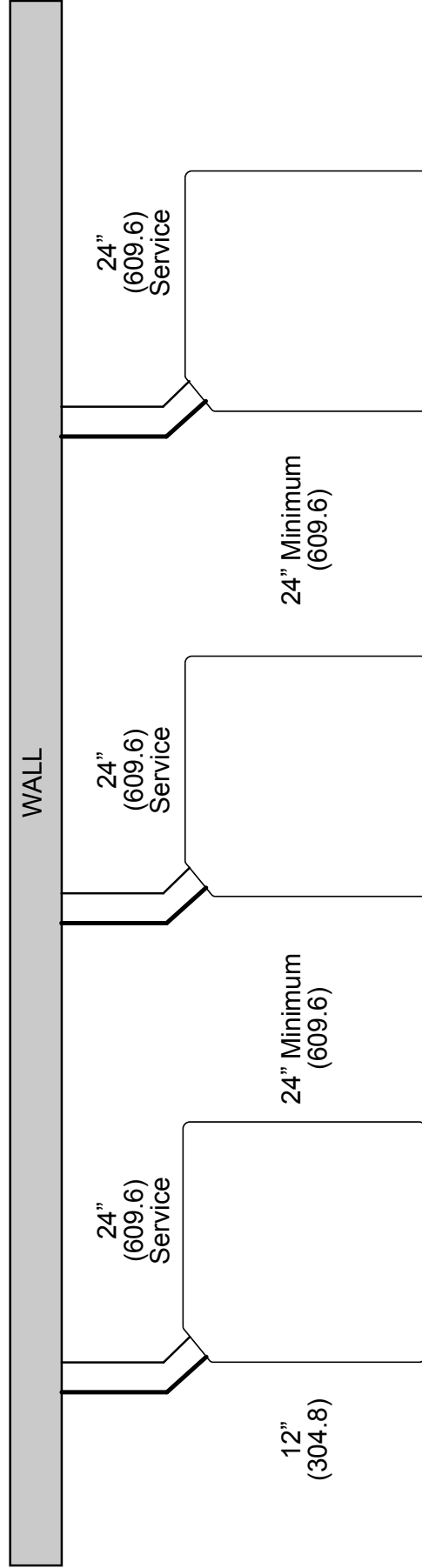
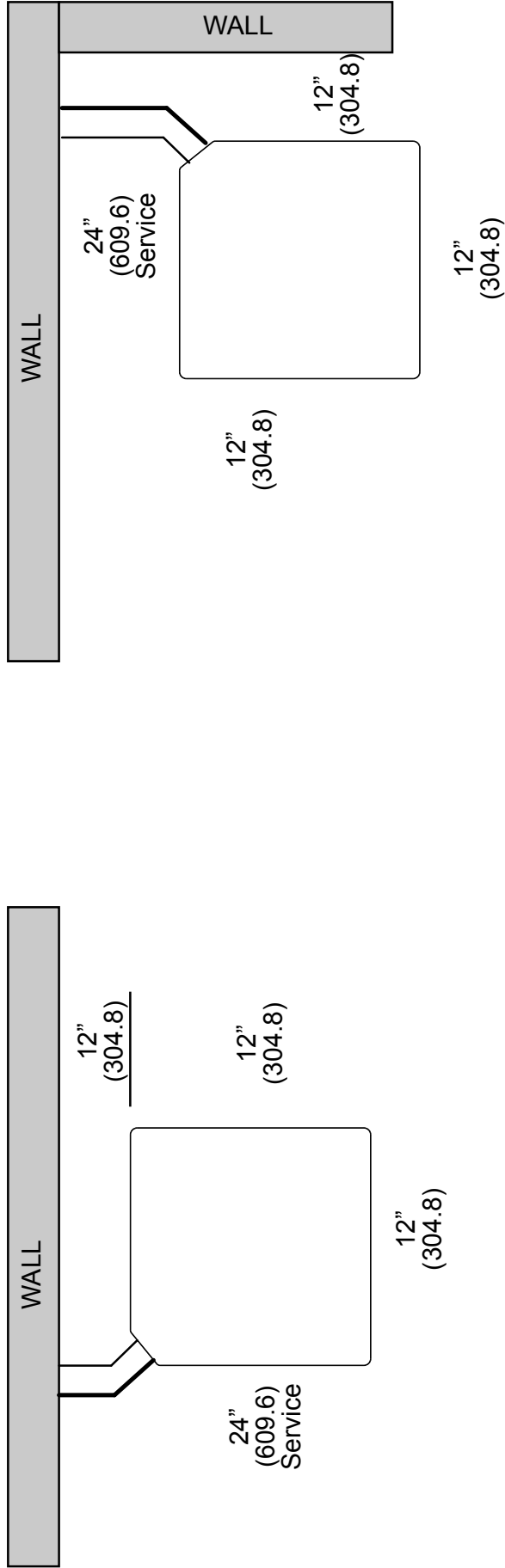

**NOTE: NUMBERS IN ( ) = mm**

IMPORTANT: When installing multiple units in an alcove, roof well or partially enclosed area, ensure there is adequate ventilation to prevent re-circulation of discharge air.

## 2.5 ELECTRICAL & PHYSICAL DATA (SEE TABLE 1)

**TABLE 1**  
ELECTRICAL AND PHYSICAL DATA – \*AGN

Model Number	Phase Frequency (Hz) Voltage (Volts)	Electrical						Physical					
		Compressor		Fan Motor Full Load Amperes (FLA)	Minimum Circuit Ampacity Amperes	Fuse or HACR		Outdoor Coil			Refrigerant Included Oz. [kg]	Weight	
		Rated Load Amperes (RLA)	Locked Rotor Amperes (LRA)			Minimum Amperes	Maximum Amperes	Face Area Sq. Ft. [m <sup>2</sup> ]	No. Rows	CFM [L/s]		Net Lbs. [kg]	Shipping Lbs. [kg]
*AGN-018J**	1-60-220-230	9/9	46	0.6	12/12	15/15	20/20	7.13 [0.66]	1	1415 [668]	67.4 [1.911]	120 [54.4]	128 [58.1]
*AGN-024J**	1-60-220-230	13.5/13.5	58.3	0.6	18/18	25/25	30/30	8.43 [0.78]	1	1665 [786]	67.8 [1.922]	121 [54.9]	129 [58.5]
*AGN-030J**	1-60-220-230	12.8/12.8	64	0.8	17/17	20/20	25/25	8.7 [0.81]	1	2075 [979]	75 [2.126]	139 [63.1]	147 [66.7]
*AGN-036J**	1-60-220-230	16.7/16.7	79	0.9	22/22	30/30	35/35	13.72 [1.27]	1	2540 [1199]	90.6 [2.569]	149 [67.6]	157 [71.2]
*AGN-042J**	1-60-220-230	17.9/17.9	112	1.2	24/24	30/30	40/40	13.72 [1.27]	1	2540 [1199]	106 [3.005]	149 [67.6]	157 [71.2]
*AGN-048J**	1-60-220-230	21.8/21.8	117	1.2	29/29	35/35	50/50	16.39 [1.52]	1	3290 [1553]	116.1 [3.291]	188 [85.3]	192 [87.1]
*AGN-060J**	1-60-220-230	26.4/26.4	134	1.2	35/35	45/45	60/60	19.17 [1.78]	1	3380 [1595]	157.2 [4.457]	223 [101.2]	234 [106.1]
*AGN-018T**	1-50-220-240	10/10	52	0.5	12/12	15/15	20/20	8.43 [0.78]	1	1600 [755]	69 [1.956]	121 [54.9]	129 [58.5]
*AGN-024T**	1-50-220-240	10.9/10.9	60	0.5	15/15	20/20	25/25	8.43 [0.78]	1	1600 [755]	82.9 [2.350]	121 [54.9]	129 [58.5]
*AGN-030T**	1-50-220-240	15/15	67	0.68	18/18	25/25	30/30	19.28 [1.79]	1	2517 [1188]	124.8 [3.538]	223 [101.2]	234 [106.1]
*AGN-036T**	1-50-220-240	17.9/17.9	87	2.8	23/23	30/30	35/35	21.85 [2.03]	1	3666 [1730]	176 [4.989]	205 [93]	225 [102.1]

NOTE: Factory Refrigerant Charge includes refrigerant for 15 feet of standard line set.

**TABLE 1 - continued**  
ELECTRICAL AND PHYSICAL DATA – \*AHM

Model Number	Phase Frequency (Hz) Voltage (Volts)	Electrical						Physical					
		Compressor		Fan Motor Full Load Amperes (FLA)	Minimum Circuit Ampacity Amperes	Fuse or HACR Circuit Breaker		Outdoor Coil			Refrig. Per Circuit Oz. [g]	Weight	
		Rated Load Amperes (RLA)	Locked Rotor Amperes (LRA)			Minimum Amperes	Maximum Amperes	Face Area Sq. Ft. [m <sup>2</sup> ]	No. Rows	CFM [L/s]		Net Lbs. [kg]	Shipping Lbs. [kg]
Rev. 3/11/2010													
19	1-60-208/230	9/9	46	0.5	12/12	15/15	20/20	11.819 [1.10]	1	2805 [1324]	87 [2466]	154 [69.9]	171 [77.6]
25	1-60-208/230	13.5/13.5	58.3	0.36	18/18	25/25	30/30	8.5 [0.78]	1	2805 [1324]	91 [2580]	154 [69.9]	171 [77.6]
30	1-60-208/230	12.8/12.8	64	1.4	18/18	25/25	30/30	16.39 [1.52]	1	2915 [979]	112 [2126]	157 [63.1]	175 [66.7]
36	1-60-208/230	16.7/16.7	79	1.9	23/23	30/30	35/35	21.85 [2.03]	1	3435 [1621]	130.4 [3697]	181 [82.1]	201 [91.2]
42	1-60-208/230	17.9/17.9	112	2.8	26/26	30/30	40/40	21.85 [2.03]	1	3550 [1675]	145.12 [4114]	205 [93]	225 [102.1]
48	1-60-208/230	21.8/21.8	117	2.8	31/31	40/40	50/50	21.85 [2.03]	2	4310 [2034]	216 [6124]	249 [112.9]	269 [122]
49	1-60-208/230	19.9/19.9	109	1.9	27/27	35/35	45/45	21.85 [2.03]	2	3615 [1706]	213 [6039]	249 [112.9]	269 [122]
56	1-60-208/230	21.4/21.4	135	1.9	29/29	35/35	50/50	21.85 [2.03]	2	3615 [1706]	241 [6832]	254 [115.2]	274 [124.3]
60	1-60-208/230	26.4/26.4	134	2.8	36/36	45/45	60/60	21.85 [2.03]	2	4105 [1937]	240 [6804]	254 [115.2]	274 [124.3]

**TABLE 1 - continued**  
ELECTRICAL AND PHYSICAL DATA – \*AGL

Model Number	Phase-Hertz-Voltage	Comp RLA	Comp LRA	Motor FLA	Minimum Circuit Ampacity	Calc. Fuse Sizes		Outdoor Coil		CFM [L/s]	R-410A Charge Weight (Oz.) [kg]
						Min. (Amps)	Max. (Amps)	Area Sq. Ft. [m <sup>2</sup> ]	Rows		
*AGL-018T**	1-50-220-240	7.9	44	0.6	12	15	15	11.06 [1.03]	1	1645 [776]	61 [1.73]
*AGL-024T**	1-50-220-240	10	52	0.6	17	20	20	11.06 [1.03]	1	1700 [802]	70 [1.98]
*AGL-030T**	1-50-220-240	12.5	60	0.8	19	25	25	13.72 [1.27]	1	2370 [1118]	78 [2.21]
*AGL-036T**	1-50-220-240	15	67	0.8	23	30	30	16.39 [1.52]	1	2805 [1324]	95 [2.69]
*AGL-036N**	3-50-380/415	6.4	38	1	10	15	15	16.39 [1.52]	1	2805 [1324]	102 [2.89]
*AGL-042T**	1-50-220-240	17.9	87	1.2	2.9	35	35	16.39 [1.52]	1	2805 [1324]	101 [2.86]
*AGL-042N**	3-50-380/415	6.6	44	1	12	15	15	16.39 [1.52]	1	2805 [1324]	104 [2.95]
*AGL-048T**	1-50-220-240	17.7	98	1.2	29	35	35	21.85 [2.03]	1	3295 [1555]	149 [4.22]
*AGL-048N**	3-50-380/415	6.9	41	1	12	15	15	21.85 [2.03]	1	3295 [1555]	142 [4.02]
*AGL-060N**	3-50-380/415	8.9	52	1	15	20	20	21.85 [2.03]	1	3295 [1555]	172 [4.88]
*AGL-065N**	3-50-380/415	11.8	75	1	15	20	20	21.85 [2.03]	1	3295 [1555]	180 [5.10]

\*S or V

NOTE: Factory Refrigerant Charge includes refrigerant for 15 feet [4.5 m] of standard line set.

\*\* - May be followed by additional suffix indicating factory installed options and/or specific energy label models.

**MATCH ALL COMPONENTS:**

- **OUTDOOR UNIT**
- **INDOOR COIL/METERING DEVICE**
- **INDOOR AIR HANDLER/FURNACE**
- **REFRIGERANT LINES**

## **3.0 LOCATING UNIT**

### **3.1 CORROSIVE ENVIRONMENT**

The metal parts of this unit may be subject to rust or deterioration if exposed to a corrosive environment. This oxidation could shorten the equipment's useful life. Corrosive elements include, but are not limited to, salt spray, fog or mist in seacoast areas, sulphur or chlorine from lawn watering systems, and various chemical contaminants from industries such as paper mills and petroleum refineries.

If the unit is to be installed in an area where contaminants are likely to be a problem, special attention should be given to the equipment location and exposure.

- Avoid having lawn sprinkler heads spray directly on the unit cabinet.
- In coastal areas, locate the unit on the side of the building away from the waterfront.
- Shielding provided by a fence or shrubs may give some protection, but cannot violate minimum airflow and service access clearances.
- Elevating the unit off its slab or base enough to allow air circulation will help avoid holding water against the basepan.

Regular maintenance will reduce the build-up of contaminants and help to protect the unit's finish.

### **WARNING**

**DISCONNECT ALL POWER TO UNIT BEFORE STARTING MAINTENANCE. FAILURE TO DO SO CAN CAUSE ELECTRICAL SHOCK RESULTING IN SEVERE PERSONAL INJURY OR DEATH.**

- Frequent washing of the cabinet, fan blade and coil with fresh water will remove most of the salt or other contaminants that build up on the unit.
- Regular cleaning and waxing of the cabinet with an automobile polish will provide some protection.
- A liquid cleaner may be used several times a year to remove matter that will not wash off with water.

Several different types of protective coatings are offered in some areas. These coatings may provide some benefit, but the effectiveness of such coating materials cannot be verified by the equipment manufacturer.

### **3.2 CONDENSER LOCATION**

Consult local and national building codes and ordinances for special installation requirements. Following location information will provide longer life and simplified servicing of the outdoor condenser.

### **3.3 OPERATIONAL ISSUES**

- **IMPORTANT:** Locate the condenser in a manner that will not prevent, impair or compromise the performance of other equipment horizontally installed in proximity to the unit. Maintain all required minimum distances to gas and electric meters, dryer vents, exhaust and inlet openings. In the absence of National Codes, or manufacturers' recommendations, local code recommendations and requirements will take precedence.
- Refrigerant piping and wiring should be properly sized and kept as short as possible to avoid capacity losses and increased operating costs.
- Locate the condenser where water run off will not create a problem with the equipment. Position the unit away from the drip edge of the roof whenever possible. Units are weatherized, but can be affected by water pouring into the unit from the junction of rooflines, without protective guttering.

### **3.4 FOR CONDENSERS WITH SPACE LIMITATIONS**

In the event that a space limitation exists, we will permit the following clearances:

**Single Unit Applications:** One condenser inlet air grille side may be reduced to no less than a 6-inch clearance. Clearances below 6 inches will reduce unit capacity and efficiency. Do not reduce the 60-inch discharge, or the 24-inch service clearances.

**Multiple Unit Applications:** When multiple condenser grille sides are aligned, a 6-inch per unit clearance is recommended, for a total of 12 inches between two units. Two combined clearances below 12 inches will reduce capacity and efficiency. Do not reduce the 60-inch discharge, or 24-inch service, clearances.



### 3.5 CUSTOMER SATISFACTION ISSUES

- The condenser should be located away from the living, sleeping and recreational spaces of the owner and those spaces on adjoining property.
- To prevent noise transmission, the mounting pad for the outdoor unit should not be connected to the structure, and should be located sufficient distance above grade to prevent ground water from entering the unit.

### 3.6 PROPER INSTALLATION

Proper sizing and installation of equipment is critical to achieve optimal performance. Use the information in this Installation Instruction Manual and reference the applicable Engineering Specification Sheet when installing this product.

### 3.7 UNIT MOUNTING

If elevating the condensing unit, either on a flat roof or on a slab, observe the following guidelines.

- The base pan provided elevates the condenser coil 3/4" above the base pad.
- If elevating a unit on a flat roof, use 4" x 4" (or equivalent) stringers positioned to distribute unit weight evenly and prevent noise and vibration.

---

## 4.0 REFRIGERANT CONNECTIONS

All units are factory charged with Refrigerant 410A. All models are supplied with service valves. Keep tube ends sealed until connection is to be made to prevent system contamination.

---

## 5.0 TOOLS AND REFRIGERANT [\*] AGL-AGN-AHM MODELS

### TOOLS REQUIRED FOR INSTALLING AND SERVICING R-410A MODELS

Manifold Sets:

- Up to 800 PSIG High Side
- Up to 250 PSIG Low Side
- 550 PSIG Low Side Retard

Manifold Hoses:

- Service Pressure Rating of 800 PSIG

Recovery Cylinders:

- 400 PSIG Pressure Rating
- Dept. Of Transportation ABA400 or BW400

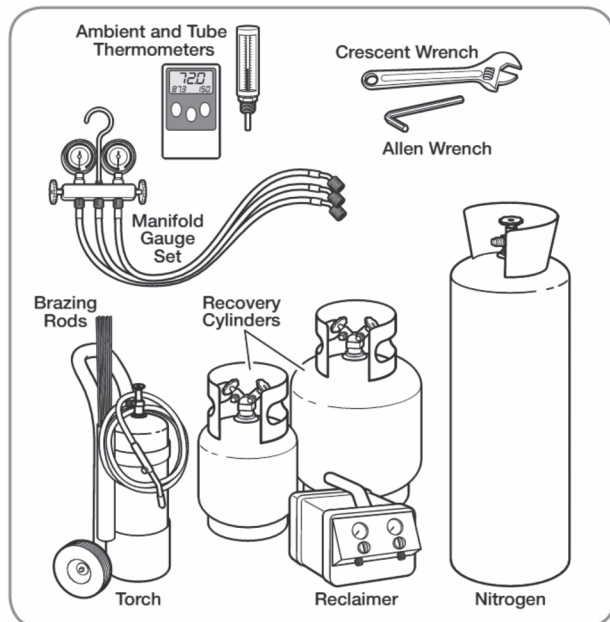

## CAUTION

*R-410A systems operate at higher pressures than R-22 systems. Do not use R-22 service equipment or components on R-410A equipment.*

### 5.1 SPECIFICATIONS OF R-410A

**Application:** R-410A is not a drop in replacement for R-22. Equipment designs must accommodate its higher pressures. It cannot be retrofitted into R-22 heat pumps.

**Physical Properties:** R-410A has an atmospheric boiling point of -62.9°F [-52.7°C] and its saturation pressure at 77°F [25°C] is 224.5 PSIG.

**Composition:** R-410A is a near-azeotropic mixture of 50% by weight difluoromethane (HFC-32) and 50% by weight pentafluoroethane (HFC-125).

**Pressures: The Pressure of R-410A is approximately 60% (1.6 times) greater than R-22.** Recovery and recycle equipment, pumps, hoses and the like must have design pressure ratings appropriate for R-410A.

**Combustibility:** At pressures above 1 atmosphere, a mixture of R-410A and air can become combustible.

**R-410A and air should never be mixed in tanks or supply lines, or be allowed to accumulate in storage tanks. Leak checking should never be done with a mixture of R-410A and air.** Leak checking can be performed safely with nitrogen or a mixture of R410A and nitrogen.

### 5.2 QUICK REFERENCE GUIDE FOR R-410A

- R-410A refrigerant operates at approximately 60% higher pressure (1.6 times) than R-22. Ensure that servicing equipment is designed to operate with R-410A.
- R-410A refrigerant cylinders are light rose in color.
- R-410A, as with other HFC's, is only compatible with POE oils.
- Vacuum pumps will not remove moisture from POE oil used in R-410A systems.
- R-410A systems are to be charged with liquid refrigerant. Prior to March, 1999, R-410A refrigerant cylinders had a dip tube. These cylinders should be kept upright for equipment charging. Post-March 1999 cylinders do not have a dip tube and should be inverted to ensure liquid charging of the equipment.
- Do not install a suction line filter drier in the liquid line.
- A factory approved liquid line filter drier is shipped with every unit and must be installed in the liquid line at the time of installation. These filter driers are rated for a minimum working pressure of 600 PSIG. The filter drier will only have adequate moisture-holding capacity if the system is properly evacuated.
- Desiccant (drying agent) must be compatible for POE oils and R-410A Refrigerant.

## 6.0 REPLACEMENT UNITS

To prevent failure of a new unit, the existing line set must be correctly sized and cleaned or replaced. Care must be exercised that the expansion device is not plugged. For new and replacement units, a liquid line filter drier must be installed and refrigerant tubing must be properly sized. Test the oil for acid. If positive, a suction line filter drier is mandatory.

**IMPORTANT:** If replacing an R-22 unit with an R-410A unit, either replace the line set or ensure that residual mineral oil is drained from the existing lines, including oil trapped in low spots.

## 7.0 INDOOR COIL

### CAUTION

Only use evaporators approved for use on R-410A systems that are specifically matched with the outdoor unit per the manufacturer's specifications. Use of existing R-22 evaporators can introduce mineral oil into the R-410A refrigerant, forming two different liquids and decreasing oil return to the compressor. This can result in compressor failure.

### REFER TO INDOOR AIR HANDLER MANUFACTURER'S INSTALLATION INSTRUCTIONS.

**IMPORTANT:** The manufacturer is not responsible for the performance and operation of a mismatched system, or for a match listed with another manufacturer's coil.

The thermostat expansion valve (TXV or TEV) in the matching coil is specifically designed to operate with R-410A.

**DO NOT use an R-22 TXV or evaporator. The existing evaporator must be replaced with the factory specified TXV evaporator specifically designed for R-410A.**

### 7.1 LOCATION

Do not install the indoor evaporator coil in the return duct system of a gas or oil furnace. Provide a service inlet to the coil for inspection and cleaning. Keep the coil pitched toward the drain connection.

### CAUTION

When a coil, air handler or condensing gas furnace is installed over a finished ceiling and/or living area, it is strongly recommended that a secondary condensate pan be installed under the entire unit. Failure to do so can result in property damage.

## 8.0 SELECTING AND SIZING LINE SETS [(\*)-AGL-AGN-AHM MODELS]

### 8.1 LINE SETS AND FITTING LOSSES

Refrigerant lines are measured in terms of actual length and equivalent length. Actual length is used for refrigerant charge applications and is the measurement of all of the vertical and horizontal lines from the indoor and outdoor units. Equivalent length takes into account pressure losses from line lengths, fittings, vertical separations, accessories, and filter dryers. Table 2 Equivalent Lengths below provides equivalent lengths for different commonly used parts in refrigerant lines. Equivalent length is the sum of the actual length of the line set plus the equivalent length of all fittings, accessories, and filter dryers. Equivalent length is used in determining proper line sizing and installation.

TABLE 2

Equivalent Length for Fittings (ft)							
Line Size (in)	90° Short Radius Elbow	90° Long Radius Elbow	45° Elbow	Solenoid Valve	Check Valve	Site Glass	Filter Dryer
3/8	1.3	0.8	0.3	6	4	0.4	6
1/2	1.4	0.9	0.4	9	5	0.6	6
5/8	1.5	1	0.5	12	6	0.8	6
3/4	1.9	1.3	0.6	14	7	0.9	6
7/8	2.3	1.5	0.7	15	8	1	6
1-1/8	2.7	1.8	0.9	22	12	1.5	6

## 8.2 LIQUID LINE SELECTION

The purpose of the liquid line is to transport warm sub-cooled liquid refrigerant from the outdoor unit to the indoor unit. It is important to maintain a column of liquid all the way to the expansion device and not to allow the refrigerant to flash into superheated vapor. The flashing of refrigerant can occur for the following reasons:

- Low refrigerant charge
- Improperly selected liquid line size
- Absorption of heat prior to expansion device
- Excessive vertical rise between the condenser and evaporator

The procedure for selecting the proper liquid line size and length is as follows:

- Measure the total amount of vertical rise (elevation).
- Measure the actual amount of liquid line required.
- Add all of the equivalent lengths associated with any fittings or accessories.
- Add the actual length and equivalent lengths. This will equal your total equivalent length.
- Reference the Line Sizing Chart that matches the application (e.g. ODU above, ODU below, ODU same elevation as the IDU3) and the capacity size of the equipment.

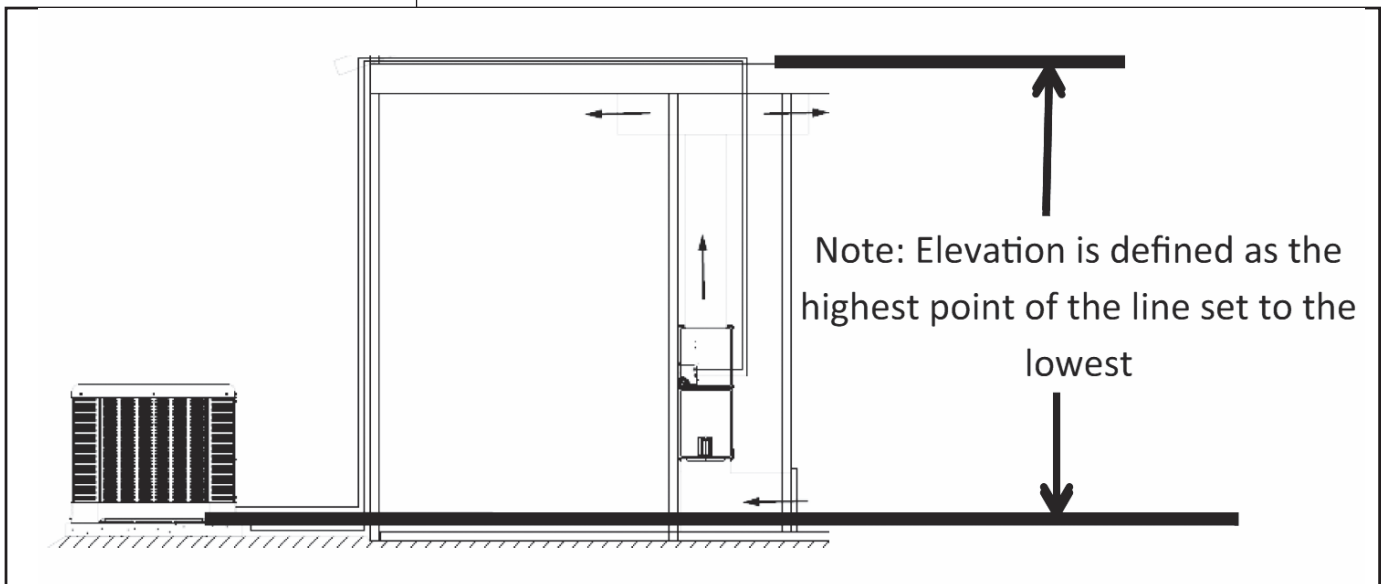

### LIQUID LINE SELECTION (CONT.)

- Verify that the value of the calculated total equivalent length is compatible with the applications vertical rise and diameter of the liquid line.
- Using the equivalent length total and the vertical rise in the application (if required) to determine the size and allowable lengths of the liquid line piping.

#### Liquid Line General Notes:

- Regardless of equivalent length, the actual linear length of the tubing shall not exceed 200'.
- Design of the liquid line must not exceed 400 FPM and must have a minimum of 100 FPM.
- Liquid lines must be sized to minimize refrigerant pressure change.
- Sufficient refrigerant sub-cooling must be maintained at the expansion device for proper system operation.
- R-410A loses 0.43 PSI for every foot of vertical lift as a liquid. Length of pipe, fittings, liquid line filter drier also add pressure drop thus limiting applications where the outdoor unit is below the indoor unit to much shorter distances than when the outdoor unit is above the indoor unit.
- When the outdoor unit is above the indoor unit, the vertical line experiences an increase in PSIG (Static Gain) which will also lead to changes in subcooling at the metering device.
- The total pressure drop allowed for the liquid line is 50 PSI.

### 8.3 VAPOR SUCTION LINE SELECTION

The purpose of the suction line is to return superheated vapor to the compressor from the evaporator. Suction line sizing and refrigerant velocity is important as they have a role in ensuring the return of oil to the compressor. An improperly sized suction line can reduce performance of the system.

The procedure for selecting the proper liquid line size is as follows:

Measure the total amount of vertical rise (elevation).

- Measure the actual amount of suction line required.
- Add all of the equivalent lengths associated with any fittings or accessories using Table 1.
- Add the actual length and equivalent lengths. This will equal your total equivalent length of suction line.
- Reference the Line Sizing Charts that matches the application (e.g. ODU above, below, or same elevation as the IDU) and the capacity size of the equipment.
- Verify that the value of the calculated total equivalent length is compatible with the applications vertical rise and diameter of the liquid line.
- Using the equivalent length total and the vertical rise in the application (if required) to determine the size and allowable lengths of the liquid line piping.

#### Suction Line General Notes:

- The Manufacturer does NOT require traps in the suction line when the condenser is above the evaporator, and recommends they not be used. The combination of miscibility of the POE oil and R-410A, along with compliance to the refrigerant line design instructions will ensure oil is properly returned without exceeding pressure drop limits in the vapor line. Traps will add to the pressure drop and therefore are counterproductive when the suction line is sized according to these guidelines.
- Refrigerant velocity for vertical suction risers must be maintained at 1100 FPM to ensure oil return. Horizontal suction lines must maintain 800 FPM. This will often result in different size refrigerant lines between horizontal and vertical applications. While gravity has very little effect on the gas itself, oil and pressure drop are still key factors.
- It is acceptable to use the larger size suction line for shorter horizontal runs and in applications where the indoor unit is above the outdoor unit to prevent capacity losses.
- Pressure drop within the suction line should be limited to 5 psi for R410A systems although the longest lines may slightly exceed this limit in an effort to maintain velocity. The maximum pressure is 7 psi.
- Suction line pressure loss reduces capacity by 0.6% for R-410A per psi. In order to minimize capacity loss suction pressure loss must be minimized.

### 8.4 REFRIGERANT LEVEL ADJUSTMENT

The residential outdoor units (ODU) are R-410A factory charged. The factory charge amount accounts for the ODU volume and an additional 15 feet of refrigerant tubing with a liquid line diameter of 3/8". This factory charge does not account for the volume of the factory supplied, field installed liquid line filter drier. Final adjustment of the refrigerant charge may be necessary during the system commissioning even if the application has exactly 15 feet of line set due to other installation variables such as the filter drier and pressure drops due to vertical separation. If additional refrigerant charge is needed it should be added before opening the ODU valves.

Adjust the refrigerant charge by using the actual liquid line length and the table below that indicates refrigerant charge in ounces per foot of the indicated liquid line size:

- 1/4" line diameter uses 0.3 ounces per foot of line (6.4 mm uses 8.5g per .30 m)
- 5/16" line diameter uses 0.4 ounces per foot of line (7.9mm uses 11.3g per .30m)
- 3/8" line diameter uses 0.6 ounces per foot of line (9.5mm uses 17.0g per .30 m)
- 1/2" line diameter uses 1.2 ounces per foot of line (12.7mm uses 34.0g per .30 m)
- **NOTE:** The factory provided filter drier requires an additional 6.0 ounces of refrigerant.
- **NOTE:** The factory provided charge to account for the 15 feet of line set is 9 oz. (based on 3/8" line, 0.6 oz. per foot)

Charge Adjustment = (Line Diameter oz. per ft.) x Total Actual Length) – Factory Charge + Filter Drier

**Example:**

A 3 ton unit with 50' of 5/16" liquid line (actual length) and the factory provided filter drier. In this case 5/16" diameter line requires 0.4 ounces per foot of liquid line length.

1. Multiply 50 ft. x 0.4 ounces per foot = 20 ounces
2. Add 6.0 ounces needed for the field installed drier
3. Subtract the 9.0 ounces of the factory charge that is already in the system and was designated for the 15' of refrigerant line.

Answer: 20 oz. + 6.0 oz. – 9.0 oz. = 17 ounces of additional refrigerant charge is required.

**8.5 ADDITIONAL OIL ADJUSTMENT**

All refrigerant in the system will carry a small amount of oil. As more refrigerant is added to the system, additional oil will also need to be added.

The formula for determining how much oil to add to the system is as follows:

Oil to be Added = [(Charge Adjustment + OD Unit Name Plate Charge (oz.)) x (0.022) – [(0.10) x (Compressor Name Plate Oil Charge (oz.))]

(See Tables 3, 4, and 5 – Crankcase Heaters for Unit Nameplate Charge (oz.) values)

**Example:**

- Charge adjustment: 17 ounces
- Unit Name Plate Charge: 107 ounces
- Nameplate Oil charge: 25 ounces
  - o [(17+170) x (0.022)] – [(0.10 x 25)]
  - o [187 x 0.022] – [2.5]
  - o 4.1 – 2.5
  - o 1.6

Add 1.6 ounces of POE oil to system.

**8.6 LONG LINE SET APPLICATIONS**

This section is intended for long line applications as noted in the light grey shaded areas in the Line Sizing Charts. Long line set applications require accessories, unit specific requirements, and long line set installation considerations. The following are special considerations required when installing a line set that is considered to be a long line set.

- Long line Set Accessories
- Long Line Set Unit Requirements
- Long Line Installations Considerations
- Additional Refrigerant Charge
- Additional Oil Level Adjustment
- Fitting losses and maximum equivalent length considerations.
- Refrigerant Migration in the off cycle
- Oil Return to the compressor
- Capacity losses

**8.7 LONG LINE SET ACCESSORIES**

**Crankcase Heater**

Some models come from the factory with crankcase heaters already installed. See the Crankcase Heater table to determine if the accessory needs to be ordered and field installed.

**Hard Start Kit (SK-A1)**

In applications with long line sets, one characteristic will be added refrigerant. Hard Start components will increase the starting torque of the compressor in order to overcome the pressure differential on the compressor. See the Hard Start Kit Accessory Part number SK-A1 to order and field install.

**TABLE 3  
COMPRESSOR/FACTORY OIL CHARGE/CRANKCASE HEATERS**

SAGN Model	Compressor Part Number Compressor Model	Compressor Name Plate Factory Oil Charge (oz.)	Factory Installed CCH (Yes or No)	Crankcase Heater Part Number
*AGN-018JA	55-102045-82 ZP14K5E-PFV-130	25	N	44-103663-08
*AGN-024JA	55-102045-24 ZP20K5E-PFV-130	25	N	44-103663-08
*AGN-030JA	55-102045-31 ZP24K5E-PFV-130	25	N	44-103663-08
*AGN-036JA	55-102045-03 ZP31K5E-PFV-130	25	N	44-103663-08
*AGN-042JA	55-102045-15 ZP34K5E-PFV-130	42	N	44-103663-13
*AGN-048JA	55-102045-09 ZP42K5E-PFV-130	42	N	44-103663-13
*AGN-060JA	55-102045-26 ZP51K5E-PFV-130	42	N	44-103663-13
*AGN-018TA	55-102045-56 ZP20K5E-PFJ-130	25	N	44-103663-08
*AGN-024TA	55-102045-153 ZP24K5E-PFJ-130	25	N	44-103663-08
*AGN-030TA	55-102045-50 ZP31K5E-PFJ-130	25	N	44-103663-08
*AGN-036TA	55-102045-51 ZP36K5E-PFJ-130	42	N	44-103663-13

**TABLE 5  
COMPRESSOR/FACTORY OIL CHARGE/CRANKCASE HEATERS**

(*AGL 50 Hz Model)	Compressor Part Number/ Compressor Model	Compressor Name Plate Factory Oil Charge (oz)	Factory Installed CCH (Yes or No)	Crankcase Heater Part Number	Factory Installed Oil Separator
*AGL-018TA	55-102045-47/ ZP16K5E-PFJ-130	25	N	44-103663-08	--
*AGL-018TS	55-102045-47/ ZP16K5E-PFJ-130	25	N	44-103663-08	Y
*AGL-024TA	55-102045-48/ ZP21K5E-PFJ-130	25	N	44-103663-08	--
*AGL-024TS	55-102045-48/ ZP21KAE-PFJ-130	25	Y	44-103663-08	Y
*AGL-030TA	55-102045-49/ ZP25K5E-PFJ-130	25	N	44-103663-08	--
*AGL-030TS	55-102045-49/ ZP25K5E-PFJ-130	25	Y	44-103663-08	Y
*AGL-036NA	55-102045-04/ ZP31K5E-TFD-130	25	N	44-103663-09	--
*AGL-036TA	55-102045-50/ ZP31K5E-PFJ-130	25	N	44-103663-08	--
*AGL-036TS	55-102045-50/ ZP31K5E-PFJ-130	25	Y	44-103663-08	Y
*AGL-042NA	55-102045-25/ ZP36K5E-TFD-130	42	N	44-103663-06	--
*AGL-042NS	55-102045-25/ ZP36K5E-TFD-130	42	Y	44-103663-06	Y
*AGL-042TA	55-102045-51/ ZP36K5E-PFJ-130	42	N	44-103663-13	--
*AGL-048NA	55-102045-10 ZP42K5E-TFD-130	42	N	44-103663-06	--
*AGL-048NS	55-102045-10 ZP42K5E-TFD-130	42	N	44-103663-06	Y
*AGL-048TA	55-102045-52/ ZP42K5E-PFJ-130	42	N	44-103663-13	--
*AGL-060NA	55-102045-16/ ZP36K5E-TF5-130	56	N	44-103663-08	--
*AGL-060NS	55-102045-16/ ZP36K5E-TF5-130	56	N	44-103663-08	Y
*AGL-065NA	55-102045-45/ ZP72KCE-TFD-130	60	N	44-101884-06	--
*AGL-065NS	55-102045-45/ ZP72KCE-TFD-130	60	Y	44-101884-06	Y

**TABLE 4  
COMPRESSOR/FACTORY OIL CHARGE/CRANKCASE HEATERS**

SAHM 60 Hz Model	Compressor Part Number/ Compressor Model	Compressor Name Plate Factory Oil Charge (oz)	Factory Installed CCH (Yes or No)	Crankcase Heater Part Number
*AHM-019JA030	55-102045-82/ ZP14K5E-PFV-130	25	N	44-103663-08
*AHM-019JS030	55-102045-82/ ZP14K5E-PFV-130	25	N	44-103663-08
*AHM-025JA030	55-102045-97/ ZP20KAE-PFV-130	21	N	44-103663-08
*AHM-025JS030	55-102045-97/ ZP20KAE-PFV-130	21	N	44-103663-08
*AHM-030JA030	55-102045-31/ ZP24K5E-PFV-130	25	N	44-103663-08
*AHM-030JS030	55-102045-31/ ZP24K5E-PFV-130	25	N	44-103663-08
*AHM-036JA030	55-102045-03/ ZP31K5E-PFV-130	25	N	44-103663-08
*AHM-036JS030	55-102045-03/ ZP31K5E-PFV-130	25	N	44-103663-08
*AHM-042JA030	55-102045-15/ ZP34K5E-PFV-130	42	N	44-103663-13
*AHM-042JS030	55-102045-15/ ZP34K5E-PFV-130	42	N	44-103663-13
*AHM-048JA030	55-102045-09/ ZP42K5E-PFV-130	42	Y	44-101884-13
*AHM-048JS030	55-102045-09/ ZP42K5E-PFV-130	42	Y	44-103663-13
*AHM-060JA030	55-102045-26/ ZP51K5E-PFV-130	42	Y	44-103663-13
*AHM-060JS030	55-102045-26/ ZP51K5E-PFV-130	42	Y	44-103663-13

# OUTDOOR UNIT ABOVE THE INDOOR UNIT

LONG LINE SET INSTRUCTIONS  
OUTDOOR UNIT ABOVE INDOOR AIR HANDLER.  
MIDDLE EAST EXPORT UNIT ONLY

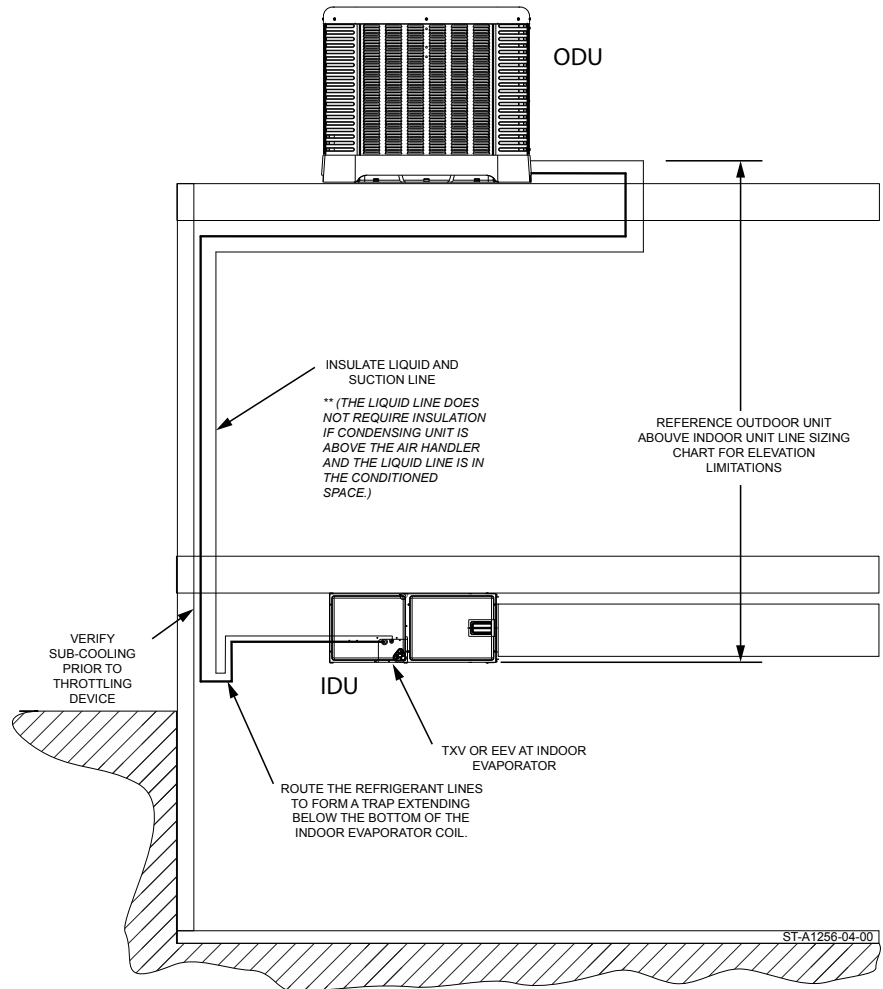

**NOTE:** Following is the chart specific to applications where the outdoor unit is **above** the indoor coil. Do not confuse charts designated with outdoor unit **below** indoor coil, with charts designated with outdoor unit **above** indoor coil.



## Outdoor Unit ABOVE Indoor Unit

Single Stage	Liquid Line Size [mm]	Suction Line Size [mm]	Equivalent Length in Meters														
			Condition - A					Condition - B					Condition - C				
			15.5-22.5	23-45	38-45	45-75	75-90	45.5-52.5	53-60	61.5-67.5	68-75	75.5-82.5	83-90				
			Maximum Vertical Separation / Capacity Multiplier														
			52.5 / 0.97														
1.5 Ton	1/4" [6.35]	5/8" [15.88]	15 / 1.00	22.5 / 0.99	33.5 / 0.99	40 / 0.98	45 / 0.96	45 / 0.96	45 / 0.96	45 / 0.96	52.5 / 0.97	58 / 0.97	55 / 0.96	55 / 0.96	52.5 / 0.96	52.5 / 0.96	60 / 0.95
	5/16" [7.94]	5/8" [15.88]	15 / 1.00	22.5 / 0.99	33.5 / 0.98	40 / 0.98	45 / 0.96	45 / 0.96	45 / 0.96	45 / 0.96	52.5 / 0.97	58 / 0.97	55 / 0.96	55 / 0.96	52.5 / 0.96	52.5 / 0.96	60 / 0.95
	3/8" [9.52.5]	5/8" [15.88]	15 / 1.00	22.5 / 0.99	33.5 / 0.98	40 / 0.98	45 / 0.96	45 / 0.96	45 / 0.96	45 / 0.96	52.5 / 0.97	60 / 0.97	60 / 0.96	60 / 0.96	60 / 0.96	60 / 0.96	60 / 0.96
2 Ton	1/4" [6.35]	5/8" [15.88]	15 / 1.00	22.5 / 0.99	33.5 / 0.98	40 / 0.97	45 / 0.95	45 / 0.95	45 / 0.95	45 / 0.94	52 / 0.97	55 / 0.96	50 / 0.95	47 / 0.95	60 / 0.95	60 / 0.95	60* / 0.94
	5/16" [7.94]	5/8" [15.88]	15 / 1.00	22.5 / 0.99	33.5 / 0.98	40 / 0.97	45 / 0.95	45 / 0.95	45 / 0.95	45 / 0.94	52.5 / 0.97	60 / 0.96	60 / 0.95	60 / 0.95	60 / 0.95	60 / 0.95	60* / 0.94
	3/8" [9.52.5]	5/8" [15.88]	15 / 0.98	22.5 / 0.97	33.5 / 0.97	40 / 0.95	45 / 0.92	45 / 0.92	45 / 0.92	45 / 0.91	52.5 / 0.94	60 / 0.93	60 / 0.93	60 / 0.92	60 / 0.92	60* / 0.92	60* / 0.91
2.5 Ton	3/8" [9.52.5]	5/8" [15.88]	15 / 1.00	22.5 / 0.99	33.5 / 0.99	40 / 0.98	45 / 0.96	45 / 0.96	45 / 0.96	45 / 0.96	52.5 / 0.98	60 / 0.98	60 / 0.97	60 / 0.97	60* / 0.97	60* / 0.97	60* / 0.96
	5/16" [7.94]	5/8" [15.88]	15 / 1.00	22.5 / 0.99	33.5 / 0.96	40 / 0.93	45 / 0.90	45 / 0.90	45 / 0.90	45 / 0.88	52.5 / 0.93	60 / 0.91	60 / 0.90	60 / 0.90	60* / 0.90	60* / 0.89	60* / 0.88
	3/8" [9.52.5]	5/8" [15.88]	15 / 0.98	22.5 / 0.97	33.5 / 0.96	40 / 0.93	45 / 0.90	45 / 0.90	45 / 0.90	45 / 0.88	52.5 / 0.93	60 / 0.91	60 / 0.90	60 / 0.90	60* / 0.90	60* / 0.89	60* / 0.88
3 Ton	5/16" [7.94]	3/4" [19.06]	15 / 1.00	22.5 / 1.00	33.5 / 0.99	40 / 0.97	45 / 0.97	45 / 0.97	45 / 0.97	45 / 0.96	52.5 / 0.96	60 / 0.98	60 / 0.97	60 / 0.97	60* / 0.96	60* / 0.96	60* / 0.96
	3/8" [9.52.5]	3/4" [19.06]	15 / 1.00	22.5 / 1.00	33.5 / 0.99	40 / 0.97	45 / 0.97	45 / 0.97	45 / 0.97	45 / 0.96	52.5 / 0.96	60 / 0.98	60 / 0.97	60 / 0.97	60* / 0.96	60* / 0.96	60* / 0.96
	3/8" [9.52.5]	3/4" [19.06]	15 / 1.00	22.5 / 0.99	33.5 / 0.99	40 / 0.97	45 / 0.97	45 / 0.97	45 / 0.97	45 / 0.96	52.5 / 0.96	60 / 0.98	60 / 0.97	60 / 0.97	60* / 0.96	60* / 0.96	60* / 0.96
3.5 Ton	5/16" [7.94]	3/4" [19.06]	15 / 1.00	22.5 / 0.99	33.5 / 0.99	40 / 0.98	45 / 0.96	45 / 0.96	45 / 0.96	45 / 0.95	52.5 / 0.98	60 / 0.97	60 / 0.97	60* / 0.96	60* / 0.96	60* / 0.96	60* / 0.95
	3/8" [9.52.5]	3/4" [19.06]	15 / 1.00	22.5 / 1.00	33.5 / 1.00	40 / 0.98	45 / 0.96	45 / 0.96	45 / 0.96	45 / 0.95	52.5 / 0.98	60 / 0.97	60 / 0.97	60* / 0.96	60* / 0.96	60* / 0.96	60* / 0.95
	3/8" [9.52.5]	3/4" [19.06]	15 / 1.00	22.5 / 1.00	33.5 / 1.00	40 / 1.00	45 / 0.96	45 / 0.96	45 / 0.96	45 / 0.95	52.5 / 0.99	60 / 0.99	60 / 0.99	60* / 0.96	60* / 0.96	60* / 0.96	60* / 0.95
4 Ton	3/8" [9.52.5]	3/4" [19.06]	15 / 0.98	22.5 / 0.97	33.5 / 0.96	40 / 0.95	45 / 0.92	45 / 0.92	45 / 0.92	45 / 0.91	52.5 / 0.94	60* / 0.93	60* / 0.92	58* / 0.92	52* / 0.92	52* / 0.92	47* / 0.91
	1/2" [12.71]	3/4" [19.06]	15 / 0.98	22.5 / 0.97	33.5 / 0.96	40 / 0.95	45 / 0.92	45 / 0.92	45 / 0.92	45 / 0.91	52.5 / 0.94	60 / 0.93	60 / 0.92	60 / 0.92	60* / 0.92	60* / 0.92	60* / 0.91
	3/8" [9.52.5]	7/8" [22.22.5]	15 / 1.00	22.5 / 0.98	33.5 / 0.98	40 / 0.97	45 / 0.96	45 / 0.96	45 / 0.96	45 / 0.96	52.5 / 0.97	60* / 0.97	60* / 0.96	58* / 0.96	52* / 0.96	52* / 0.96	47* / 0.96
5 Ton	1/2" [12.71]	7/8" [22.22.5]	15 / 1.00	22.5 / 0.98	33.5 / 0.98	40 / 0.97	45 / 0.96	45 / 0.96	45 / 0.96	45 / 0.96	52.5 / 0.97	60 / 0.97	60 / 0.96	60 / 0.96	60* / 0.96	60* / 0.96	60* / 0.96
	3/8" [9.52.5]	3/4" [19.06]	15 / 0.98	22.5 / 0.96	33.5 / 0.95	40 / 0.93	45 / 0.90	45 / 0.90	45 / 0.90	45 / 0.90	52.5 / 0.92	60* / 0.92	55* / 0.91	49* / 0.90	60* / 0.90	60* / 0.90	60* / 0.89
	1/2" [12.71]	3/4" [19.06]	15 / 0.98	22.5 / 0.96	33.5 / 0.95	40 / 0.93	45 / 0.90	45 / 0.90	45 / 0.90	45 / 0.89	52.5 / 0.92	60 / 0.92	60 / 0.91	60 / 0.91	60* / 0.90	60* / 0.90	60* / 0.89
5 Ton	3/8" [9.52.5]	7/8" [22.22.5]	15 / 1.00	22.5 / 0.99	33.5 / 0.98	40 / 0.97	45 / 0.95	45 / 0.95	45 / 0.95	45 / 0.95	52.5 / 0.97	60* / 0.96	55* / 0.96	49* / 0.95	60* / 0.96	60* / 0.96	60* / 0.89
	1/2" [12.71]	7/8" [22.22.5]	15 / 1.00	22.5 / 0.99	33.5 / 0.98	40 / 0.97	45 / 0.95	45 / 0.95	45 / 0.95	45 / 0.95	52.5 / 0.97	60 / 0.96	60 / 0.96	60 / 0.96	60* / 0.96	60* / 0.96	60* / 0.94
	1/2" [12.71]	7/8" [22.22.5]	15 / 1.00	22.5 / 0.99	33.5 / 0.98	40 / 0.97	45 / 0.95	45 / 0.95	45 / 0.95	45 / 0.95	52.5 / 0.97	60 / 0.96	60 / 0.96	60 / 0.96	60* / 0.96	60* / 0.96	60* / 0.94

Condition:	Total Equivalent Length	Max. Vertical Separation
A	Standard unit	<33.5
B	Use Oil Separator recommended and Crank case heater.	34 ~ 45
C	Use Oil Separator, Crank case heater, Hard Start Kit and Non-bleed TXV.	45.1 ~ 60
Black	Not Recommended	
*	* Applications with asterisks (*) require a minimum of 15m vertical separation.	

# OUTDOOR UNIT BELOW THE INDOOR UNIT

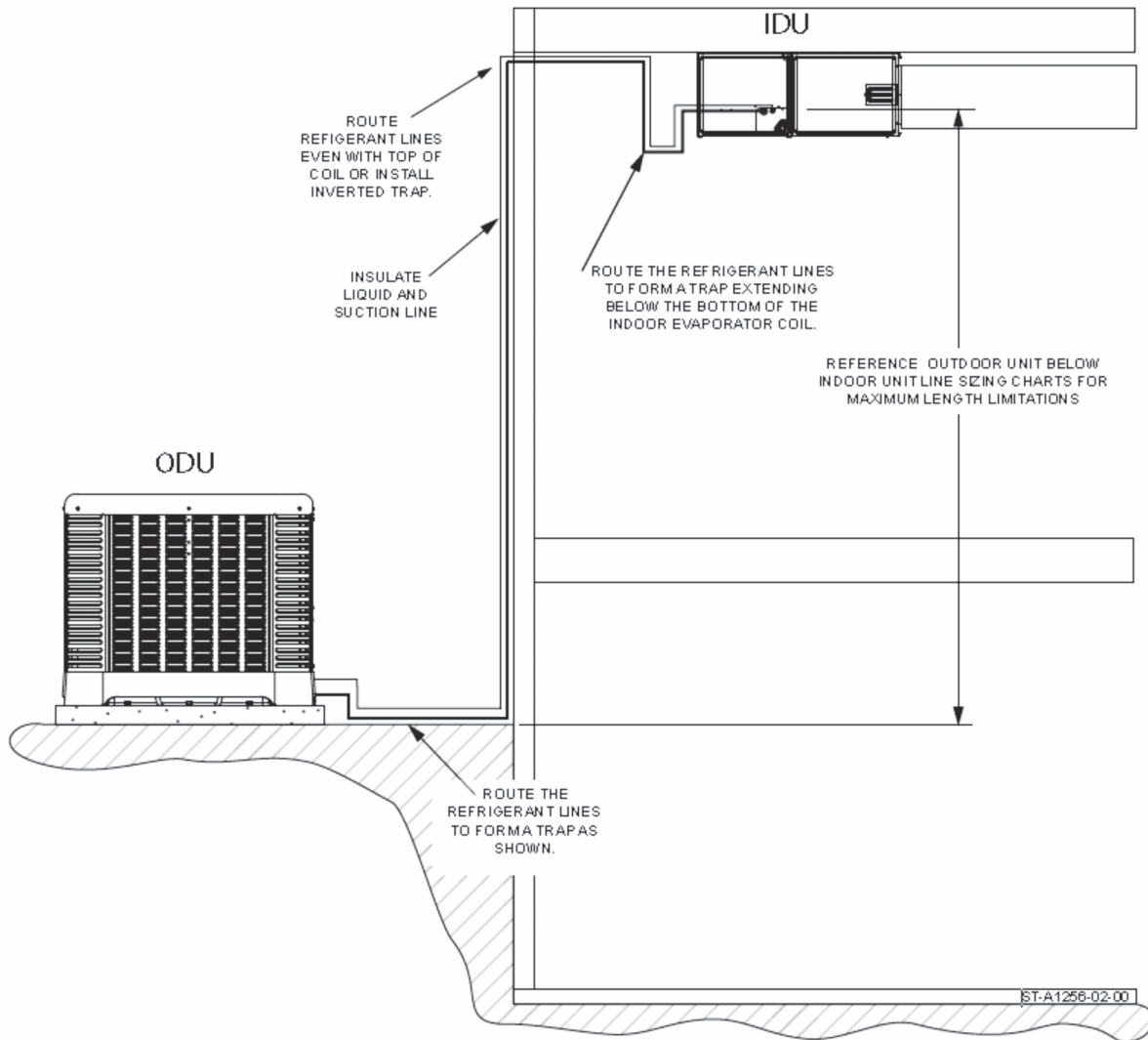

**NOTE:** Following is the chart specific to applications where the outdoor unit is **below** the indoor coil. Do not confuse charts designated with outdoor unit **above** indoor coil, with charts designated with outdoor unit **below** indoor coil.

## Outdoor Unit BELOW Indoor Unit

Single Stage	Liquid Line Size [mm]	Suction Line Size [mm]	Equivalent Length in Meter																					
			Maximum vertical Separation / Capacity Multiplier																					
			<15	15.5-22.5	23-30	30.5-37.5	38 - 45	45.5-52.5	53-60	61.5-67.5	68-75	75.6-82.5	83-90											
1.5 Ton	5/16" [7.94]	5/8" [15.88]	15/0.99	21.0/0.99	18/0.98	13.5/0.98	10.5/0.98	6/0.97	3/0.97															
	3/8" [9.52.5]	5/8" [15.88]	15/0.99	22.5/0.99	24.5/0.98	24.5/0.98	24.5/0.98	24.5/0.97	24.5/0.97	24.5/0.97	24.5/0.96	24.5/0.96	24.5/0.96	24.5/0.96	24.5/0.96	24.5/0.96	24.5/0.96	24.5/0.96	24.5/0.96	24.5/0.96	24.5/0.96	15/0.95		
	5/16" [7.94]	3/4" [19.06]	15/1.00	21.0/1.00	18/1.00	13.5/1.00	10.5/0.99	6/0.99	3/0.99															
	3/8" [9.52.5]	3/4" [19.06]	15/1.00	22.5/1.00	24.5/1.00	24.5/1.00	24.5/0.99	24.5/0.99	24.5/0.99	24.5/0.99	24.5/0.99	24.5/0.99	24.5/0.99	24.5/0.99	24.5/0.99	24.5/0.99	24.5/0.99	24.5/0.99	24.5/0.99	24.5/0.99	24.5/0.99	24.5/0.99	15/0.99	
	5/16" [7.94]	5/8" [15.88]	15/1.00	13.5/0.99	25/0.98																			
2 Ton	3/8" [9.52.5]	5/8" [15.88]	15/1.00	22.5/0.99	24.5/0.98	24.5/0.98	24.5/0.97	24.5/0.96	24.5/0.95	24.5/0.95	24.5/0.94	24.5/0.94	24.5/0.94	24.5/0.94	24.5/0.94	24.5/0.94	24.5/0.94	24.5/0.94	24.5/0.94	24.5/0.94	24.5/0.94	24.5/0.94	3/0.93	
	5/16" [7.94]	3/4" [19.06]	15/1.00	13.5/1.00	25/1.00																			
	3/8" [9.52.5]	3/4" [19.06]	15/1.00	22.5/1.00	24.5/1.00	24.5/1.00	24.5/0.99	24.5/0.99	24.5/0.99	24.5/0.99	24.5/0.99	24.5/0.99	24.5/0.99	24.5/0.99	24.5/0.99	24.5/0.99	24.5/0.99	24.5/0.99	24.5/0.99	24.5/0.99	24.5/0.99	24.5/0.99	3/0.98	
	5/16" [7.94]	5/8" [15.88]	12/09.8	3/0.97																				
	3/8" [9.52.5]	5/8" [15.88]	15/0.98	22.5/0.97	24.5/0.97	24.5/0.96	24.5/0.96	24.5/0.95	24.5/0.94	24.5/0.93	24.5/0.93	24.5/0.93	24.5/0.93	24.5/0.93	24.5/0.93	24.5/0.93	24.5/0.93	24.5/0.93	24.5/0.93	24.5/0.93	24.5/0.93	24.5/0.93	15/0.92	
2.5 Ton	5/16" [7.94]	3/4" [19.06]	12/1.00	3/0.99																				
	3/8" [9.52.5]	3/4" [19.06]	15/1.00	22.5/0.99	24.5/0.99	24.5/0.99	24.5/0.98	24.5/0.98	24.5/0.98	24.5/0.98	24.5/0.98	24.5/0.98	24.5/0.98	24.5/0.98	24.5/0.98	24.5/0.98	24.5/0.98	24.5/0.98	24.5/0.98	24.5/0.98	24.5/0.98	24.5/0.98	15/0.97	
	5/16" [7.94]	3/4" [19.06]	10.5/1.00	10/0.99																				
	3/8" [9.52.5]	3/4" [19.06]	15/1.00	22.5/0.99	24.5/0.98	24.5/0.98	24.5/0.98	24.5/0.97	24.5/0.97	24.5/0.97	24.5/0.97	24.5/0.97	24.5/0.97	24.5/0.97	24.5/0.97	24.5/0.97	24.5/0.97	24.5/0.97	24.5/0.97	24.5/0.97	24.5/0.97	24.5/0.97	10/0.96	
	1/2" [12.7]	3/4" [19.06]	15/1.00	22.5/0.99	24.5/0.98	24.5/0.98	24.5/0.98	24.5/0.97	24.5/0.97	24.5/0.97	24.5/0.97	24.5/0.97	24.5/0.97	24.5/0.97	24.5/0.97	24.5/0.97	24.5/0.97	24.5/0.97	24.5/0.97	24.5/0.97	24.5/0.97	24.5/0.97	24.5/0.97	24.5/0.95
3 Ton	3/8" [9.52.5]	7/8" [22.23]	15/1.00	22.5/1.00	24.5/1.00	24.5/1.00	24.5/0.99	24.5/0.99	24.5/0.99	24.5/0.99	24.5/0.99	24.5/0.99	24.5/0.99	24.5/0.99	24.5/0.99	24.5/0.99	24.5/0.99	24.5/0.99	24.5/0.99	24.5/0.99	24.5/0.99	24.5/0.99	24.5/0.99	10/0.98
	1/2" [12.7]	7/8" [22.23]	15/1.00	22.5/1.00	24.5/1.00	24.5/1.00	24.5/0.99	24.5/0.99	24.5/0.99	24.5/0.99	24.5/0.99	24.5/0.99	24.5/0.99	24.5/0.99	24.5/0.99	24.5/0.99	24.5/0.99	24.5/0.99	24.5/0.99	24.5/0.99	24.5/0.99	24.5/0.99	24.5/0.99	24.5/0.98
	3/8" [9.52.5]	3/4" [19.06]	15/0.99	22.5/0.99	24.5/0.98	24.5/0.98	24.5/0.97	24.5/0.97	24.5/0.97	24.5/0.97	24.5/0.96	24.5/0.96	24.5/0.96	24.5/0.96	24.5/0.96	24.5/0.96	24.5/0.96	24.5/0.96	24.5/0.96	24.5/0.96	24.5/0.96	24.5/0.96	24.5/0.96	21.0/0.95
	1/2" [12.7]	3/4" [19.06]	15/0.99	22.5/0.99	24.5/0.98	24.5/0.98	24.5/0.97	24.5/0.97	24.5/0.97	24.5/0.97	24.5/0.96	24.5/0.96	24.5/0.96	24.5/0.96	24.5/0.96	24.5/0.96	24.5/0.96	24.5/0.96	24.5/0.96	24.5/0.96	24.5/0.96	24.5/0.96	24.5/0.96	18/0.94
	3/8" [9.52.5]	7/8" [22.23]	15/1.00	22.5/1.00	24.5/1.00	24.5/1.00	24.5/1.00	24.5/0.99	24.5/0.99	24.5/0.99	24.5/0.99	24.5/0.99	24.5/0.99	24.5/0.99	24.5/0.99	24.5/0.99	24.5/0.99	24.5/0.99	24.5/0.99	24.5/0.99	24.5/0.99	24.5/0.99	24.5/0.99	24.5/0.98
3.5 Ton	1/2" [12.7]	7/8" [22.23]	15/1.00	22.5/1.00	24.5/1.00	24.5/1.00	24.5/1.00	24.5/1.00	24.5/1.00	24.5/1.00	24.5/1.00	24.5/1.00	24.5/1.00	24.5/1.00	24.5/1.00	24.5/1.00	24.5/1.00	24.5/1.00	24.5/1.00	24.5/1.00	24.5/1.00	24.5/1.00	24.5/1.00	21.0/0.95
	3/8" [9.52.5]	3/4" [19.06]	15/0.99	22.5/0.99	24.5/0.98	24.5/0.98	24.5/0.97	24.5/0.97	24.5/0.97	24.5/0.97	24.5/0.96	24.5/0.96	24.5/0.96	24.5/0.96	24.5/0.96	24.5/0.96	24.5/0.96	24.5/0.96	24.5/0.96	24.5/0.96	24.5/0.96	24.5/0.96	24.5/0.96	21.0/0.95
	1/2" [12.7]	7/8" [22.23]	15/1.00	22.5/1.00	24.5/1.00	24.5/1.00	24.5/1.00	24.5/0.99	24.5/0.99	24.5/0.99	24.5/0.99	24.5/0.99	24.5/0.99	24.5/0.99	24.5/0.99	24.5/0.99	24.5/0.99	24.5/0.99	24.5/0.99	24.5/0.99	24.5/0.99	24.5/0.99	24.5/0.99	21.0/0.98
	3/8" [9.52.5]	3/4" [19.06]	15/0.99	22.5/0.99	24.5/0.98	24.5/0.98	24.5/0.97	24.5/0.97	24.5/0.97	24.5/0.97	24.5/0.96	24.5/0.96	24.5/0.96	24.5/0.96	24.5/0.96	24.5/0.96	24.5/0.96	24.5/0.96	24.5/0.96	24.5/0.96	24.5/0.96	24.5/0.96	24.5/0.96	18/0.94
	1/2" [12.7]	7/8" [22.23]	15/1.00	22.5/1.00	24.5/1.00	24.5/1.00	24.5/1.00	24.5/0.99	24.5/0.99	24.5/0.99	24.5/0.99	24.5/0.99	24.5/0.99	24.5/0.99	24.5/0.99	24.5/0.99	24.5/0.99	24.5/0.99	24.5/0.99	24.5/0.99	24.5/0.99	24.5/0.99	24.5/0.99	21.0/0.98
4 Ton	3/8" [9.52.5]	3/4" [19.06]	15/0.99	22.5/0.99	24.5/0.98	24.5/0.98	24.5/0.97	24.5/0.97	24.5/0.97	24.5/0.97	24.5/0.96	24.5/0.96	24.5/0.96	24.5/0.96	24.5/0.96	24.5/0.96	24.5/0.96	24.5/0.96	24.5/0.96	24.5/0.96	24.5/0.96	24.5/0.96	24.5/0.96	15/0.95
	1/2" [12.7]	3/4" [19.06]	15/0.99	22.5/0.99	24.5/0.98	24.5/0.98	24.5/0.97	24.5/0.97	24.5/0.97	24.5/0.97	24.5/0.96	24.5/0.96	24.5/0.96	24.5/0.96	24.5/0.96	24.5/0.96	24.5/0.96	24.5/0.96	24.5/0.96	24.5/0.96	24.5/0.96	24.5/0.96	24.5/0.96	18/0.95
	3/8" [9.52.5]	7/8" [22.23]	15/1.00	22.5/1.00	24.5/1.00	24.5/1.00	24.5/1.00	24.5/0.99	24.5/0.99	24.5/0.99	24.5/0.99	24.5/0.99	24.5/0.99	24.5/0.99	24.5/0.99	24.5/0.99	24.5/0.99	24.5/0.99	24.5/0.99	24.5/0.99	24.5/0.99	24.5/0.99	24.5/0.99	15/0.98
	1/2" [12.7]	7/8" [22.23]	15/1.00	22.5/1.00	24.5/1.00	24.5/1.00	24.5/1.00	24.5/0.99	24.5/0.99	24.5/0.99	24.5/0.99	24.5/0.99	24.5/0.99	24.5/0.99	24.5/0.99	24.5/0.99	24.5/0.99	24.5/0.99	24.5/0.99	24.5/0.99	24.5/0.99	24.5/0.99	24.5/0.99	18/0.95
	3/8" [9.52.5]	3/4" [19.06]	15/0.98	22.5/0.98	24.5/0.97	24.5/0.96	24.5/0.96	24.5/0.95	24.5/0.95	24.5/0.95	24.5/0.95	24.5/0.95	24.5/0.95	24.5/0.95	24.5/0.95	24.5/0.95	24.5/0.95	24.5/0.95	24.5/0.95	24.5/0.95	24.5/0.95	24.5/0.95	24.5/0.95	12/0.94
5 Ton	1/2" [12.7]	3/4" [19.06]	15/0.98	22.5/0.98	24.5/0.97	24.5/0.96	24.5/0.96	24.5/0.95	24.5/0.95	24.5/0.95	24.5/0.95	24.5/0.95	24.5/0.95	24.5/0.95	24.5/0.95	24.5/0.95	24.5/0.95	24.5/0.95	24.5/0.95	24.5/0.95	24.5/0.95	24.5/0.95	24.5/0.95	12/0.97
	1/2" [12.7]	3/4" [19.06]	15/0.98	22.5/0.98	24.5/0.97	24.5/0.96	24.5/0.96	24.5/0.95	24.5/0.95	24.5/0.95	24.5/0.95	24.5/0.95	24.5/0.95	24.5/0.95	24.5/0.95	24.5/0.95	24.5/0.95	24.5/0.95	24.5/0.95	24.5/0.95	24.5/0.95	24.5/0.95	24.5/0.95	15/0.94
	3/8" [9.52.5]	7/8" [22.23]	15/1.00	22.5/0.99	24.5/0.99	24.5/0.98	24.5/0.98	18/0.97	18/0.97	18/0.97	18/0.97	18/0.97	18/0.97	18/0.97	18/0.97	18/0.97	18/0.97	18/0.97	18/0.97	18/0.97	18/0.97	18/0.97	18/0.97	6/0.96
	1/2" [12.7]	7/8" [22.23]	15/1.00	22.5/0.99	24.5/0.99	24.5/0.98	24.5/0.98	24.5/0.98	24.5/0.98	24.5/0.98	24.5/0.98	24.5/0.98	24.5/0.98	24.5/0.98	24.5/0.98	24.5/0.98	24.5/0.98	24.5/0.98	24.5/0.98	24.5/0.98	24.5/0.98	24.5/0.98	24.5/0.98	12/0.97
	1/2" [12.7]	7/8" [22.23]	15/1.00	22.5/0.99	24.5/0.99	24.5/0.98	24.5/0.98	24.5/0.97	24.5/0.97	24.5/0.97	24.5/0.97	24.5/0.97	24.5/0.97	24.5/0.97	24.5/0.97	24.5/0.97	24.5/0.97	24.5/0.97	24.5/0.97	24.5/0.97	24.5/0.97	24.5/0.97	24.5/0.97	9/0.96

**Notes:**

Always use the smallest Liquid Line allowable to keep system charge to a minimum

Additional refrigerant and oil may be required (see Application Notes)

Vertical separation cannot Exceed 24.5 meter of length.

Light grey shaded areas require long line set application (Oil Separator, Crank Case Heater, Hard Start Kit and Non-bleed TXV).

These areas in the chart are not applicable for installation.

## **8.8 LONG LINE SET UNIT REQUIREMENTS**

### **Non-Bleed TXV's on Indoor Coils**

All air handler coils are shipped with factory installed non-bleed TXV's. If this TXV is replaced it will require a non-bleed type.

## **8.9 LONG LINE INSTALLATION CONSIDERATIONS**

### **Liquid Line Sizing**

Reference the Selection and Sizing Line Sets section, Liquid Lines in this guide.

- Minimize pressure change
- Ensure sub-cooled liquid at the expansion device
- Size as small as possible without exceeding the recommended maximum pressure drop

### **Liquid Line Insulation**

When the liquid line is run through an unconditioned space for any significant length, it is subject to losing or gaining heat from the ambient air. This can cause refrigerant to flash in the liquid line prior to the TXV.

### **Suction Line Sizing**

Reference the Selection and Sizing Line Sets section, Suction Lines in this guide.

- Minimize pressure loss
- In applications where ODU is Above IDU maintain refrigerant gas velocity to ensure oil return

### **Suction Line Insulation**

Insulation may be required on the vapor line if it is traveling through, at extended distances, an unconditioned space. Insulation slows the transfer of heat absorbed by the cool vapor line preventing excess superheat by the time the refrigerant gets to the compressor.

### **Inverted Trap**

When the system is installed with the outdoor unit below the indoor coil, an inverted trap, installed at the indoor coil will prevent oil and refrigerant drainage to the outdoor unit in the off cycle. An inverted trap is simply a matter of making sure the refrigerant lines exit the indoor coil and go upward to a height above the top of the coil before going back down toward the outdoor unit.

### **Refrigerant Level Adjustment**

Longline sets will require the refrigerant charge level to be adjusted. Reference the Refrigerant Level Adjustment section to determine the amount of R-410A refrigerant is required.

- Always recheck and readjust system refrigerant charge levels as needed during the final commissioning phase.

### **Additional Oil**

With long line sets as more refrigerant is added to the system, additional oil will need to be added. Reference the Additional Oil Adjustment section to determine the quantity of POE oil to add.

### **Capacity**

Use the capacity multiplier in the Line Sizing Charts to determine the impact to the system capacity based on long line set applications. Determine that the capacity meets the application requirements.

## **8.10 SUMMARY OF IMPORTANT NOTES:**

- The Maximum Actual Linear Length of the refrigerant lines shall not exceed 200 ft. [61 m].
- Equivalent Length shall not exceed 300 ft. [91.4 m].
- Maximum Vertical Separation may not exceed 200 ft. [61 m].
- Maximum Vertical Separation may not exceed 90% of the total actual length.
- Maximum Vertical Lift on liquid line may not exceed 80 ft. [24.5 m] (Outdoor Unit Below and all Heat Pumps).

- Follow Refrigerant Line Sizing Charts, do not exceed lengths, vertical separation, line diameters or total actual length described in these charts.
- Understand the difference between Actual and Equivalent Lengths. Refrigerant lines are measured in terms of actual length and equivalent length. Actual length is used for refrigerant charge applications. This is the actual line set distance between the indoor and outdoor units. Equivalent length takes into account pressure losses from refrigerant line lengths, fittings, vertical separation, accessories, and filter dryers. Table 2 Equivalent Lengths references different commonly used equivalent lengths for fittings and parts.
- Heat pump line sizing charts only apply to Heat Pumps. Because refrigerant flows both directions, depending on operating mode or defrost, vertical separation is limited to 80 ft. [24.5 m]. DO NOT attempt to install a heat pump using the cooling only charts.
- Applications in the grey shaded areas of the Line Size Charts (Long Line Set) require the use of appropriate accessories, unit requirements, and installation considerations.
- Applications in the blacked out areas on the liquid line tables exceed manufacture recommendations.
- Additional refrigerant may be required depending on the system application.
- Additional Oil will be required when the refrigerant volume is increased.
- Additional refrigerant line insulation may be required on the vapor line and/or liquid line.
- Inverted Traps are used when the indoor coil is above the outdoor coil. This prevents oil from draining out of the evaporator in the off cycle which can accumulate near the compressor.
- See Models Compressor/Factory Oil Charge/ Crankcase Heaters Tables for information regarding factory oil charge and factory installed crankcase heaters and oil separators.

---

## 9.0 INTERCONNECTING TUBING

Installation of split-systems should be performed by qualified service technicians with proper training in the installation, service and repair of such systems.

The following serves as a guideline for proper piping and installation. Be sure to read these instructions along with the equipment installation instructions carefully and adhere to all cautions, warnings, and general practice guidelines. Consult local building and mechanical codes for special requirements.

The tables and application data in this document will assist to better apply ducted split systems to achieve maximum efficiency, performance and reliability.

### 9.1 GENERAL GUIDELINES LINE INSTALLATION

Observe the following when installing correctly sized type “L” refrigerant lines between the indoor coil and outdoor unit.

- Use the correct Line Sizing Charts based on the system capacity and application to determine the appropriate suction and liquid line sizes.
- If a portion of the liquid line passes through an unconditioned space that can cause a temperature change in the refrigerant, the liquid line must be insulated separately from the suction line.
- Use clean, dehydrated, sealed refrigeration grade tubing.
- Always keep lines sealed until they are in place and connections are being made.
- A factory provided filter drier is included with these R-410A units and must be field installed in the liquid line upon unit installation.
- If replacing an R-22 system with an R-410A system, and the line set is not being replaced, drain the oil from the line set paying special attention to low spots in the tubing. Flush kits are not recommended due to the risk of residual chemical agents being left in the system which are incompatible with POE oil or internal components. A maximum of 5% mineral oil remaining in the system is considered acceptable.
- If tubing is cut, be sure to de-burr the ends while holding in a position to prevent the chips from falling back into the tubing. Burrs such as those caused by the tubing cutters can affect system performance significantly.

- For best system operation, keep tubing runs as short as possible with a minimum number of elbows or bends.
- Location where the tubing is exposed to mechanical damage should be avoided. If refrigerant tubing must be run through these areas, it should be housed in a protective sleeve.
- Many service problems can be avoided by taking adequate precautions to provide an internally clean and dry system, and by using procedures and materials that conform to established standards.
- The lines should be installed so they do not obstruct service access to the equipment or indoor coil. Care must be taken not to kink or damage the tubing. Care must also be taken to minimize noise transmission from the line sets and equipment to the structure.
- Never solder liquid and vapor lines together. Make sure the liquid and vapor lines do not touch each other. They may be strapped or taped together but must be insulated from each other.
- Copper to Copper solder connections require 5% silver minimum. Copper to Brass connections require 15% silver minimum.
- Use long radius elbows whenever possible.
- Support all refrigerant lines at regular intervals with suitable hangers and brackets. DO NOT allow metal to metal contact between hangers and lines or part of the structure and lines.

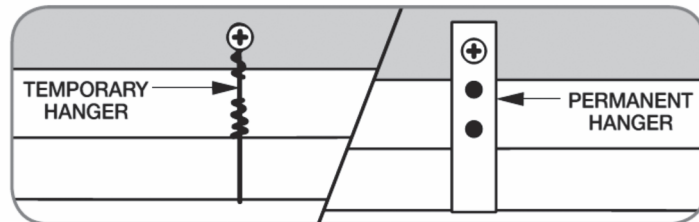

- Insulate vapor lines with minimum ½” foam insulation
- Liquid lines exposed to direct sunlight or installed in extreme temperatures, such as an attic, must be insulated as well.
- During brazing operations, lines should be purged with nitrogen to prevent oxidation and internal scaling of the inside walls of the copper tubing which can restrict refrigerant flow in small strainers, expansion valves and reversing valves.

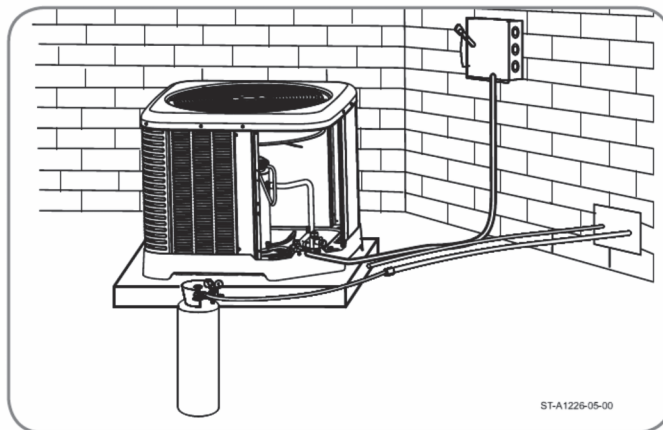

- Oil traps are not required when refrigerant lines are properly sized. Follow line sizing charts to ensure velocity, oil return and acceptable pressure drops are maintained. These charts have been developed with this critical design criteria in mind.

## 9.2 LINE SET CONNECTIONS - ODU

- Be certain both refrigerant shut off valves at the outdoor unit are closed.

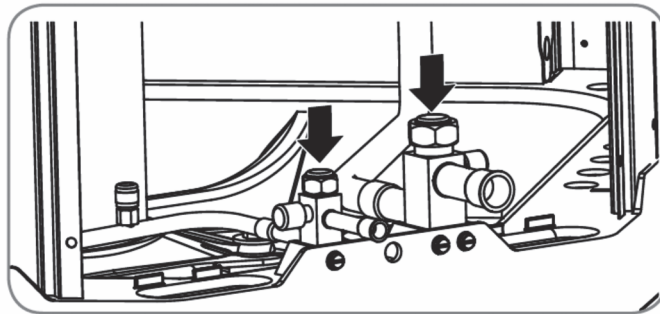

- Remove the caps and Schrader cores from the pressure ports to protect seals from heat damage. Both Schrader cores and service valves have seals that may be damaged by excessive heat.

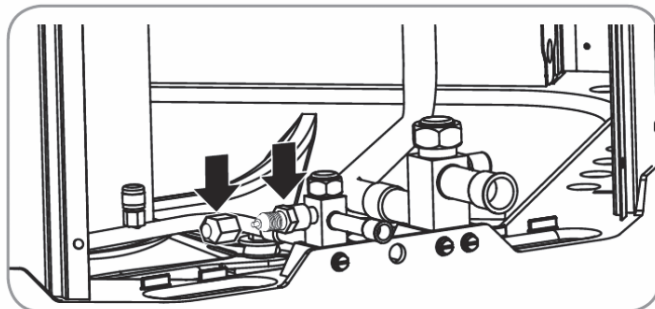

- Clean the inside of the fittings and outside of the tubing with a clean, dry cloth before soldering. Clean out debris left by chips, dirt, etc., that enters tubing or service valve connections.

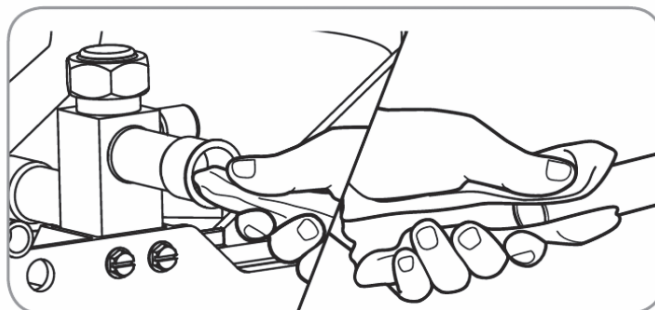

- Wrap the service valves with a wet rag or thermal barrier before applying heat.

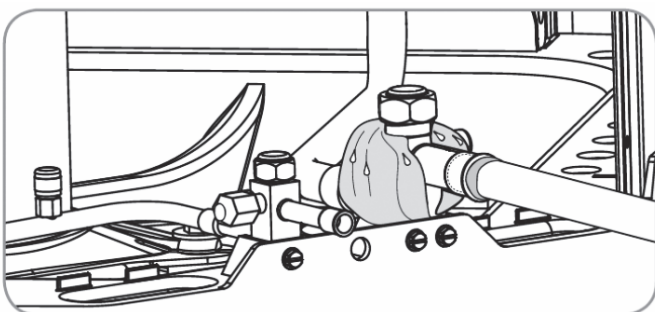

- Braze the tubing between the outdoor unit and indoor coil. Flow dry nitrogen into a pressure port and through the tubing while brazing, but do not allow pressure inside the tubing which may result in leaks. Once the system is full of nitrogen, the nitrogen regulator should be turned off to avoid pressurizing the system.

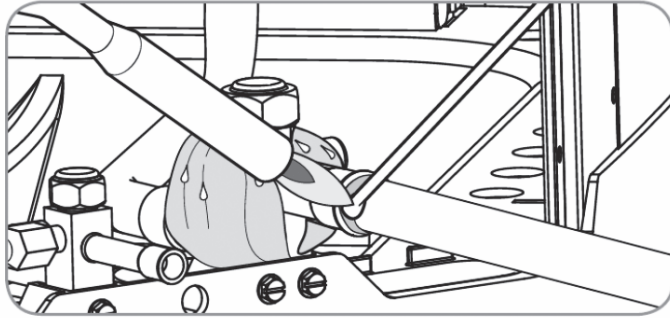

- After brazing, use an appropriate heatsink material to cool the joint.

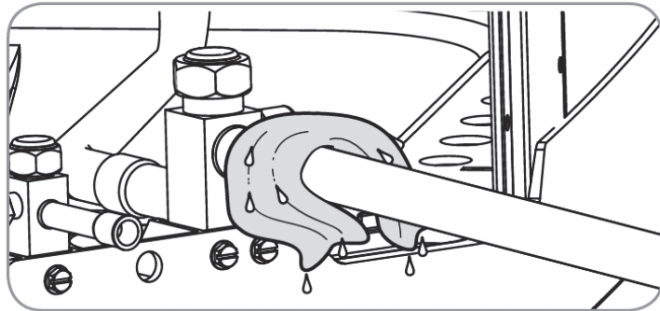

- Reinstall the Schrader cores into both pressure ports.
- Do not allow the vapor line and liquid line to be in contact with each other. This causes an undesirable heat transfer resulting in capacity loss and increased power consumption.

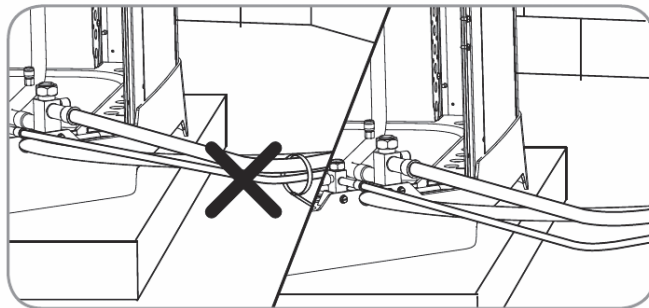

### 9.3 LINE SET LEAK TESTING

**NOTE:** Indoor coils have only a holding charge of dry nitrogen. Keep all tube ends sealed until connections are to be made.

#### **⚠ WARNING**

**DO NOT USE OXYGEN TO PURGE LINES OR PRESSURIZE SYSTEM FOR LEAK TEST. OXYGEN REACTS VIOLENTLY WITH OIL, WHICH CAN CAUSE AN EXPLOSION RESULTING IN SEVERE PERSONAL INJURY OR DEATH.**

- Pressurize line set and coil through service fittings with dry nitrogen to 150 PSIG maximum. Close nitrogen tank valve, let system sit for at least 15 minutes, and check to see if the pressure has dropped. If the pressure has dropped, check for leaks at the line set brazed joints with soap bubbles and repair leak as necessary. Repeat pressure test. If line set and coil hold pressure, proceed with line set and coil evacuation.
- The vapor line must be insulated for its entire length to prevent dripping (sweating) and prevent performance losses. Closed-cell foam insulation such as Armaflex and Rubatex® are satisfactory insulations for this purpose. Use 1/2" [12.7 mm] minimum insulation thickness. Additional insulation may be required for long runs.



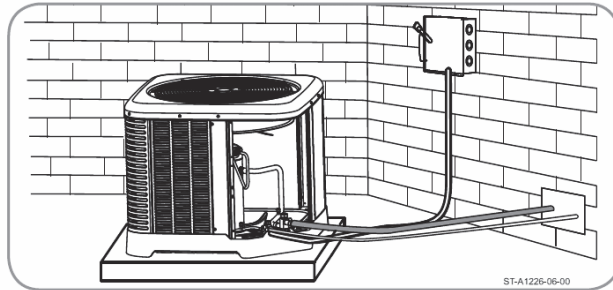

## 10.0 START-UP – CHECKING AIRFLOW

The air distribution system has the greatest effect on airflow. The duct system is totally controlled by the contractor. For this reason, the contractor should use only industry-recognized procedures. The correct air quantity is critical to air conditioning systems. Proper operation, efficiency, compressor life, and humidity control depend on the correct balance between indoor load and outdoor unit capacity. Excessive indoor airflow increases the possibility of high humidity problems. Low indoor airflow reduces total capacity and causes coil icing. Serious harm can be done to the compressor by low airflow, such as that caused by refrigerant flooding. Each ton of cooling requires between 375 and 450 cubic feet of air per minute (CFM). See the manufacturer's spec sheet for rated airflow for the system being installed. Duct design and construction should be carefully done. System performance can be lowered dramatically through bad planning or workmanship. Air supply diffusers must be selected and located carefully. They must be sized and positioned to deliver treated air along the perimeter of the space. If they are too small for their intended airflow, they become noisy. If they are not located properly, they cause drafts. Return air grilles must be properly sized to carry air back to the blower. If they are too small, they also cause noise. The installers should balance the air distribution system to ensure proper quiet airflow to all rooms in the home. This ensures a comfortable living space.

These simple mathematical formulas can be used to determine the CFM in a residential or light commercial system. Electric resistance heaters can use:

$$CFM = \frac{\text{volts} \times \text{amps} \times 3.413}{SHC \times \text{temp rise}}$$

Gas furnaces can use:

$$CFM = \frac{\text{Output Capacity in BTUH}^*}{SHC \times \text{temp rise}}$$

\*Refer to furnace data plate for furnace output capacity. SHC = Sensible Heat Constant (see table below), An air velocity meter or airflow hood can give a more accurate reading of the system CFM. The measurement for temperature rise should be performed at the indoor coil inlet and near the outlet, but out of direct line of sight of the heater element or heat exchanger. For best results, measure air temperature at multiple points and average the measurements to obtain coil inlet and outlet temperatures.

Altitude (feet)	SENSIBLE HEAT CONSTANT (SHC)	ALTITUDE (FEET)	SENSIBLE HEAT CONSTANT (SHC)
Sea Level	1.08	6000	0.87
500	1.07	7000	0.84
1000	1.05	8000	0.81
2000	1.01	9000	0.78
3000	0.97	10000	0.75
4000	0.94	15000	0.61
5000	0.90	20000	0.50

## 11.0 EVACUATION AND LEAK TESTING

### 11.1 EVACUATION PROCEDURE

Evacuation is the most important part of the entire service procedure. The life and efficiency of the equipment is dependent upon the thoroughness exercised by the serviceman when evacuating air and moisture from the system.

Air or nitrogen in the system causes high condensing temperatures and pressure, resulting in increased power input and non-verifiable performance.

Moisture chemically reacts with the refrigerant and oil to form corrosive hydrofluoric acid. This attacks motor windings and parts, causing breakdown.

- After the system has been leak-checked and proven sealed, connect the vacuum pump and evacuate system to 500 microns and hold 500 microns or less for at least 15 minutes. The vacuum pump must be connected to both the high and low sides of the system by connecting to the two pressure ports. Use the largest size connections available since restrictive service connections may lead to false readings because of pressure drop through the fittings.
- After adequate evacuation, open both service valves by removing both brass service valve caps with an adjustable wrench. Insert a 3/16" [5 mm] or 5/16" [8 mm] hex wrench into the stem and turn counterclockwise until the wrench stops.
- At this time gauges must be connected to the access fitting on the liquid line (small) service valve and the common suction port connected to the common suction line between the reversing valve and compressor to check and adjust charge.

**IMPORTANT:** Compressors (especially scroll type) should never be used to evacuate the air conditioning system because internal electrical arcing may result in a damaged or failed compressor. Never run a scroll compressor while the system is in a vacuum or compressor failure will occur.

## 11.2 FINAL LEAK TESTING

After the unit has been properly evacuated and service valves opened, a halogen leak detector should be used to detect leaks in the system. If a leak is detected, the refrigerant should be recovered before repairing the leak. The Clean Air Act prohibits releasing refrigerant into the atmosphere.

---

## 12.0 CHECKING REFRIGERANT CHARGE

### **WARNING**

**The top of the scroll compressor shell is hot. Touching the compressor top may result in serious personal injury.**

Charge for all systems should be checked against the Charging Chart inside the access panel cover.

**IMPORTANT:** Use factory-approved charging method as outlined on the next 4 pages to ensure proper system charge.

### **NOTICE**

**The optimum refrigerant charge for any outdoor unit matched with a CFL/CFM/H\*L indoor coil/air handler is affected by the application. Therefore, charging data has been developed to assist the field technician in optimizing the charge for all mounting configurations (UF – Upflow, DF – downflow, LH – Left Hand Discharge, and RH – Right Hand Discharge). Refer to the charging chart inside the access panel cover on the unit and choose the appropriate column for the specific application being installed or serviced. New installations utilizing either a CFL/CFM indoor coil installed on a gas furnace or an H\*L air handler in the downflow or horizontal right hand discharge may require removal of refrigerant since the factory charge could result in an overcharge condition.**

## 12.1 CHARGING UNITS WITH R-410A REFRIGERANT

### **CAUTION**

**R-410A pressures are approximately 60% higher (1.6 times) than R-22 pressures. Use appropriate care when using this refrigerant. Failure to exercise care may result in equipment damage or personal injury.**

Charge for all systems should be checked against the Charging Chart inside the access panel cover.

**IMPORTANT:** Do not operate the compressor without charge in the system.

## **WARNING**

**THE UNIT MUST BE PERMANENTLY GROUNDED. FAILURE TO DO SO CAN CAUSE ELECTRICAL SHOCK RESULTING IN SEVERE PERSONAL INJURY OR DEATH.**

Addition of R-410A will raise high-side pressures (liquid, and discharge). The following method is used for charging systems in the cooling and heating mode. All steps listed should be performed to insure proper charge has been set. For measuring pressures, the service valve port on the liquid valve (small valve) and the service port on the suction line between the reversing valve and compressor are to be used.

### CONFIRM ID AIR FLOW & COILS ARE CLEAN

Confirm adequate Indoor supply air flow prior to starting the system. See the Technical Specification sheet for rated air flow for each ID/OD unit match. Air filter(s) and coils (indoor & outdoor) are to be clean and free of frost prior to starting the system. Supply Air flow must be between 375 and 450 cfm per rated cooling ton prior to adjusting system charge. If a humidification system is installed disengage it from operating prior to charge adjustment. Refer to the "Checking Airflow" section of this manual for further instruction.

## **NOTICE**

**Verify system components are matched according to the outdoor unit Specification Sheet.**

### 12.2 MEASUREMENT DEVICE SETUP

- Step 1. With an R410A gauge set, attach the high pressure hose to the access fitting on the liquid line (small) service valve at the OD unit.
- Step 2. Attach the low pressure hose to the common suction port connected to the common suction line between the reversing valve and compressor.
- Step 3. Attach a temperature probe within 6" outside of the unit on the copper liquid line (small line). For more accurate measurements clean the copper line prior to measurement and use a calibrated clamp on temperature probe or an insulated surface thermocouple.

### 12.3 CHARGING BY WEIGHT

## **NOTICE**

**ADJUST THE SYSTEM CHARGE BY WEIGHT FOR THE STRAIGHT LENGTH OF THE REFRIGERANT LINE SET.**

For a new installation, evacuation of interconnecting tubing and indoor coil is adequate; otherwise, evacuate the entire system. Use the factory charge shown in "Electrical and Physical Data" on page 6 of these instructions or on the unit data plate. Note that the charge value includes charge required for 15 ft. [4.6 m] of standard-size inter-connecting liquid line without a filter drier. Calculate actual charge required with installed liquid line size and length using:

1/4" [6.4 mm] O.D. = .3 oz./ft. [8.5 g/.30 m]  
5/16" [7.9 mm] O.D. = .4 oz./ft. [11.3 g/.30 m]  
3/8" [9.5 mm] O.D. = .6 oz./ft. [17.0 g/.30 m]  
1/2" [12.7 mm] O.D. = 1.2 oz./ft. [34.0 g/.30 m]  
Add 6 oz. for field-installed filter drier.

With an accurate scale (+/- 1 oz. [28.3 g]) or volumetric charging device, adjust charge difference between that shown on the unit data plate and that calculated for the new system installation. If the entire system has been evacuated, add the total calculated charge.

**IMPORTANT:** Charging by weight is not always accurate since the application can affect the optimum refrigerant charge. Charging by weight is considered a starting point ONLY. Always check the charge by using the charging chart and adjust as necessary. CHARGING BY LIQUID SUB-COOLING MUST BE USED FOR FINAL CHARGE ADJUSTMENT.

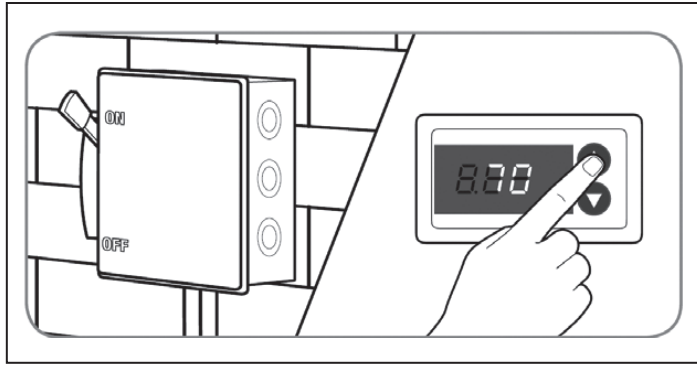

With thermostat in the “Off” position, turn the power on to the furnace or air handler. Start the furnace or air handler with the thermostat.

## 12.4 GROSS CHARGING BY PRESSURES

Step 1. Following air flow verification and charge weigh in, run the unit for a minimum of 15 minutes prior to noting pressures and temperature.

**IMPORTANT:** Indoor conditions as measured at the indoor coil must be within 2°F of the following during gross charge (pressure) evaluation:

Cooling Mode: 80°F Dry Bulb

### **⚠ NOTICE**

**If the Indoor temperature is above or below this range, run the system to bring the temperature down or run the electric heat/furnace to bring the temperature within this range. System pressure values provided in the Charge Chart for outdoor dry bulbs corresponding to conditions outside of ranges listed below, are provided as reference ONLY.**

Step 2. Note the Outdoor Dry Bulb Temperature, ODDB°F = \_\_\_\_\_°F. Unit charging is recommended under the following outdoor conditions ONLY:

Cooling Mode ONLY: 55°F outdoor dry bulb and above

Step 3. Locate and note the design pressures. The correct liquid and vapor pressures are found at the intersection of the Installed system and the outdoor ambient temperature on the Charging Chart located on the inside of the control box cover of the outdoor unit.

Liquid Pressure: = \_\_\_\_\_psig; Vapor Pressure = \_\_\_\_\_psig

### **⚠ NOTICE**

**The refrigerant pressures provided are for gross charge check ONLY. These pressure values are typical, but may vary due to application. Evaporator (indoor coil in cooling mode) load will cause pressures to deviate. Notice that all systems have unique pressure curves. The variation in the slope and value is determined by the component selection for that indoor/outdoor matched system. The variation from system to system seen in the table is normal. The values listed are for the applicable indoor coil match ONLY!**

Step 4. If the measured liquid pressure is below the listed requirement for the given outdoor and indoor conditions, add charge. If the measured liquid pressure is above the listed requirement for the given Outdoor and Indoor conditions remove charge.

## 12.5 FINAL CHARGE BY SUB-COOLING

Step 1. After gross charging note the designed Sub-Cool value. The correct sub-cooling value is found at the intersection of the Installed system and the outdoor ambient temperature on the Charging Chart located on the inside of the control box cover of the outdoor unit.

SC° from Charging Chart = \_\_\_\_\_°F.

**IMPORTANT:** Indoor conditions as measured at the indoor coil are required to be between 70°F and 80°F dry bulb for fine tune unit charge adjustment. Unit charging is recommended under the following outdoor conditions ONLY:

Cooling Mode ONLY: 55°F outdoor dry bulb and above

## NOTICE

If the Indoor temperature is above or below the recommended range, run the system to bring the temperature down or run the electric heat/furnace to bring the temperature up. System sub-cooling values provided in the Charge Chart for outdoor dry bulbs corresponding to conditions outside of the above range, are provided as reference ONLY.

Step 2. Note the measured Liquid Pressure,  $P_{liq} = \text{_____ psig}$ , as measured from the liquid (small) service valve. Use the pressure temperature chart below to note the corresponding saturation temperature for R410A at the measured liquid pressure.

Liquid Saturation Temperature,  $SAT^{\circ}F = \text{_____}^{\circ}F$ .

Step 3. Note the liquid line temperature,  $Liq^{\circ} = \text{_____}^{\circ}F$ , as measured from a temperature probe located within 6" outside of the unit on the copper liquid line (small line). It is recommended to use a calibrated clamp on temperature probe or an insulated surface thermocouple.

Step 4. Subtract the liquid line temperature (Step 3) from the saturation temperature (Step 2) to calculate Sub-Cooling.  $SAT^{\circ}F \text{_____} - Liq^{\circ} \text{_____} = SC^{\circ} \text{_____}$

Step 5. Adjust Charge to obtain the specified sub-cooling value. If the measured sub-cool is below the listed requirement for the given outdoor and indoor conditions, add charge. If the measured sub-cool is above the listed requirement for the given outdoor and indoor conditions remove charge.

**IMPORTANT:** Excessive use of elbows in the refrigerant line set can produce excessive pressure drop. Follow industry best practices for installation. Installation and commissioning of this equipment is to be performed by trained and qualified HVAC professionals. For technical assistance contact your Distributor Service Coordinator.

## 12.6 FINISHING UP INSTALLATION

- Disconnect pressure gauges from pressure ports; then replace the pressure port caps and tighten adequately to seal caps. **Do not over tighten.**
- Replace the service valve caps finger-tight and then tighten with an open-end wrench adequately to seal caps. **Do not over tighten.**
- Replace control box cover and service panel and install screws to secure service panel.
- Restore power to unit at disconnect if required.
- Configure indoor thermostat per the thermostat installation instructions and set thermostat to desired mode and temperature.

## 13.0 ELECTRICAL WIRING

Field wiring must comply with any applicable national and local codes.

### 13.1 GROUNDING

A grounding lug is provided near the line voltage power entrance for a ground wire.

## WARNING

**THE UNIT MUST BE PERMANENTLY GROUNDED. FAILURE TO DO SO CAN CAUSE ELECTRICAL SHOCK RESULTING IN SEVERE PERSONAL INJURY OR DEATH.**

### 13.2 POWER WIRING

It is important that proper electrical power from a commercial utility is available at the condensing unit contactor. Required voltage is shown on the unit rating nameplate.

Install a branch circuit disconnect within sight of the unit and adequate size to handle the starting current. (See "Electrical Data" on page 7.)

Power wiring must be run in a rain-tight conduit. Conduit must be run through the connector panel below the control box and attached to the bottom of the control

box. An electrical reducing washer similar to the one shown below may be needed to reduce the size of the conduit access hole to accommodate different sizes of conduit. A Conduit-Reducing Washer is designed to reduce the size of the knockout in a steel outlet box or other metal enclosure. It is made of galvanized steel and can be used for indoor or exterior applications.

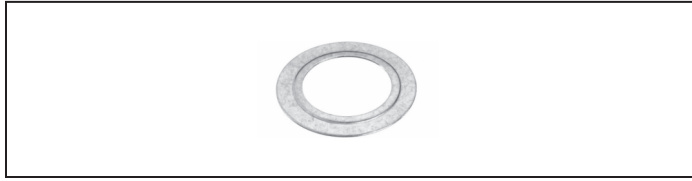

Consult national and local electrical codes to determine the required field wiring physical characteristics. A recommended typical field provided power wiring is an Armored Insulated Stranded Copper Cable that follows the typical specifications outlined below:

Manufacturing standard: BS 5467  
 Conductors: Stranded plain annealed copper wire (class 2) to BS EN 60228  
 Insulation: XLPE  
 Bedding: PVC  
 Armor: Galvanized Steel Wire Armor  
 Sheath: PVC

Following is from IEC Standard 60335-1. The table provides information for the minimum nominal cross-sectional area required for the field provided power conductors based on the rated current. Again consult national and local electrical codes for proper power wire conductor size.

Rated Current of Appliance A			Nominal Cross-Sectional Area mm <sup>2</sup>
		≤0.2	Tinsel cord <sup>a</sup>
>0.2	and	≤3	0.5 <sup>a</sup>
>3	and	≤6	0.75
>6	and	≤10	1.0 (0.75) <sup>b</sup>
>10	and	≤16	1.5 (1.0) <sup>b</sup>
>16	and	≤25	2.5
>25	and	≤32	4
>32	and	≤40	6
>40	and	≤63	10

Connect the power wiring to the contactor line voltage terminals located in the outdoor condensing unit control box (See wiring diagram attached to unit control box access panel).

Check all electrical connections, including factory wiring within the unit and make sure all connections are tight.

DO NOT connect aluminum field wire to the contactor terminals.

### 13.3 CONTROL WIRING (24 VAC)

If the low voltage control wiring is run in the same conduit with the power wiring Class 1 insulation is required on the control wiring. Class II insulation is required if run separate from the power wiring. Control wiring may be run through the insulated bushing provided in the 7/8" (22mm) hole in the base panel and up to and attached to the factory pigtail control wires in the control box. Conduit can be run to the base panel if desired by removing the bushing and attaching to the 7/8" (22mm) hole.

A zone thermostat and a 24VAC, 40VA minimum transformer is required for the control circuit of the system. Determine if a 24VAC transformer is provided in the indoor unit. See the unit wiring diagram for connection references. Use a minimum 18 gage flexible color coded thermostat wire.

# 14.0 FIELD INSTALLED ACCESSORIES

## 14.1 COMPRESSOR CRANKCASE HEAT (CCH)

While scroll compressors usually do not require crankcase heaters, there are instances when a heater should be added. Refrigerant migration during the off cycle can result in a noisy start up. Add a crankcase heater to minimize refrigerate migration, and to help eliminate any start up noise or bearing “wash out.”

**NOTE:** The installation of a crankcase heater is recommended if the system charge exceeds the values listed in Table 5 or in case of long line set requirements.

All heaters are located on the lower half of the compressor shell. Its purpose is to drive refrigerant from the compressor shell during long off cycles, thus preventing damage to the compressor during start-up.

At initial start-up or after extended shutdown periods, make sure the heater is energized for at least 12 hours before the compressor is started. (Disconnect switch on and wall thermostat off.)

**TABLE 6**  
MAXIMUM SYSTEM CHARGE VALUES – \*AGN

SAGN Model	Compressor Model Number	System Charge Limit Without Crankcase Heat
*AGN-018JA	ZP14K5E-PFV-130	9.6 lbs.
*AGN-024JA	ZP20K5E-PFV-130	9.6 lbs.
*AGN-030JA	ZP24K5E-PFV-130	9.6 lbs.
*AGN-036JA	ZP31K5E-PFV-130	9.6 lbs.
*AGN-042JA	ZP34K5E-PFV-130	12 lbs.
*AGN-048JA	ZP42K5E-PFV-130	12 lbs.
*AGN-060JA	ZP51K5E-PFV-130	12 lbs.
*AGN-018TA	ZP20K5E-PFJ-130	9.6 lbs.
*AGN-024TA	ZP24K5E-PFJ-130	9.6 lbs.
*AGN-030TA	ZP31K5E-PFJ-130	9.6 lbs.
*AGN-036TA	ZP36K5E-PFJ-130	12 lbs.

**TABLE 6 - continued**  
MAXIMUM SYSTEM CHARGE VALUES – \*AGL

Model Size	Compressor Manufacturer	Compressor Model Number	System Charge Limit Without Crankcase Heat
18T	Copeland	ZP16K5E-PFJ	8 lbs.
24T	Copeland	ZP21K5E-PFJ	8 lbs.
30T	Copeland	ZP25K5E-PFJ	8 lbs.
36T	Copeland	ZP31K5E-PFJ	8 lbs.
36N	Copeland	ZP31K5E-TFD	8 lbs.
42T	Copeland	ZP36K5E-PFJ	10 lbs.
42N	Copeland	ZP36K5E-TFD	10 lbs.
48T	Copeland	ZP42K5E-PFJ	10 lbs.
48N	Copeland	ZP42K5E-TFD	10 lbs.
60N	Copeland	ZP61KCE-TFD	12 lbs.
65N	Copeland	ZP72KCE-TFD	12 lbs.

**TABLE 6 - continued**  
MAXIMUM SYSTEM CHARGE VALUES – \*AHM

14.5 SEER Model Size	Compressor Model Number	Charge Limit Without Crankcase Heat (1 Phase)
18	ZP16K5E	9.6 lbs.
24	ZP20K5E	9.6 lbs.
30	ZP24K5E	9.6 lbs.
36	ZP31K5E	9.6 lbs.
42	ZP34K5E	12 lbs.

**NOTE:** Model sizes 48, 49, 56 and 60 have a factory installed crankcase heater.

## 14.2 TIME DELAY CONTROL RXMD-B01 (TDC)

The time delay (TDC) is in the low voltage control circuit. When the compressor shuts off due to a power failure or thermostat operation, this control keeps it off at least 5 minutes which allows the system pressure to equalize, thus not damaging the compressor or blowing fuses on start-up.

# 15.0 SERVICE

## 15.1 OPERATION

Single phase units are operated PSC (no starting components). It is important that such systems be off for a minimum of 5 minutes before restarting to allow equalization of pressure. The thermostat should not be moved to cycle unit without waiting 5 minutes. To do so may cause the compressor to go off on an automatic overload device or blow a fuse. Poor electrical service can also cause nuisance tripping on overloads, trip a breaker, or cause light dimming. This generally can be corrected by adding start components. Check with factory for recommended start components, if required. For PSC type operation, refrigerant metering must be done with fixed orifice, cap tubes or bleed type expansion valves because of low starting torque. If non-bleed expansion valve coils (supplied by factory) are used, start components are required.

## 15.2 SINGLE-POLE COMPRESSOR CONTACTOR (CC)

Single-pole contactors are used on all standard single phase units up through 5 tons. Caution must be exercised when servicing as only one leg of the power supply is broken with the contactor.

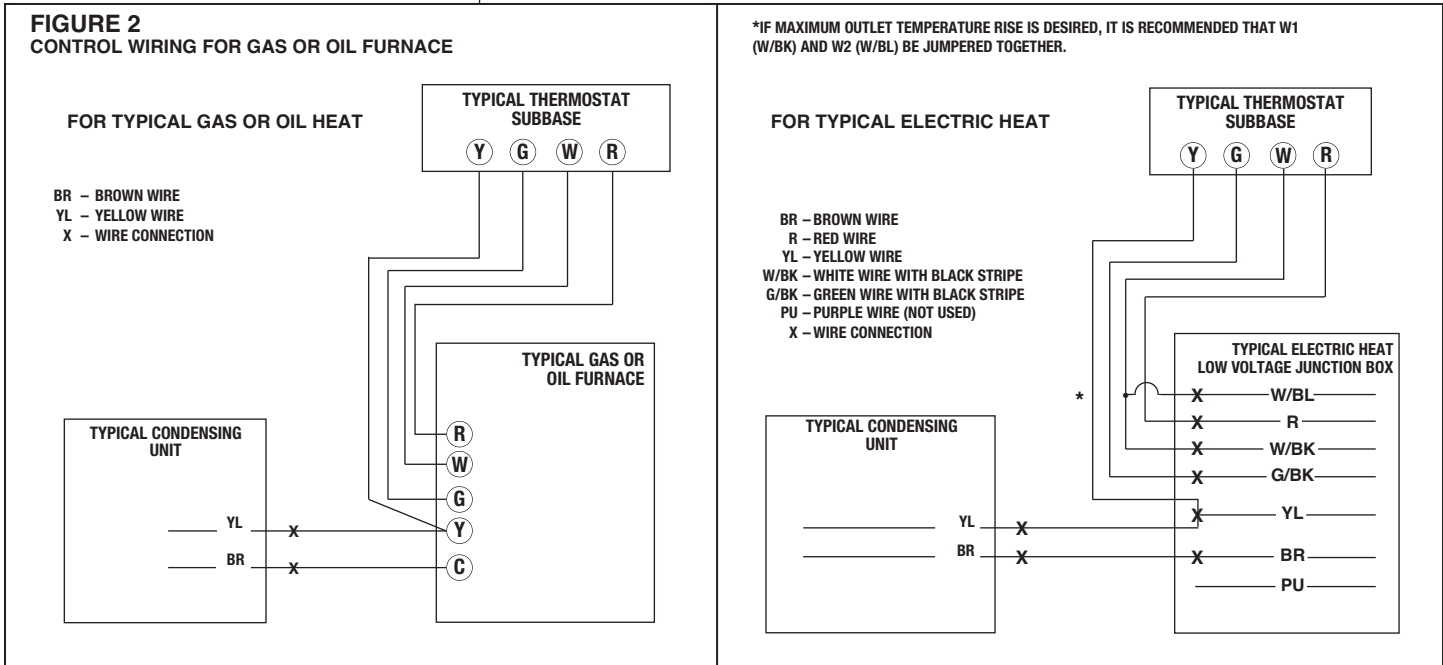



## 16.0 TROUBLE SHOOTING

In diagnosing common faults in the air conditioning system, it is useful to present the logical pattern of thought that is used by experienced technicians. The charts which follow are not intended to be an answer to all problems, but only to guide your thinking as you attempt to decide on your course of action. Through a series of yes and no answers, you will follow the logical path to a likely conclusion.

Use these charts as you would a road map, if you are a beginning technician. As you gain experience, you will learn where to establish the shortcuts. Remember that the chart will help clarify the logical path to the problem.

### 16.1 ELECTRICAL CHECKS FLOW CHART

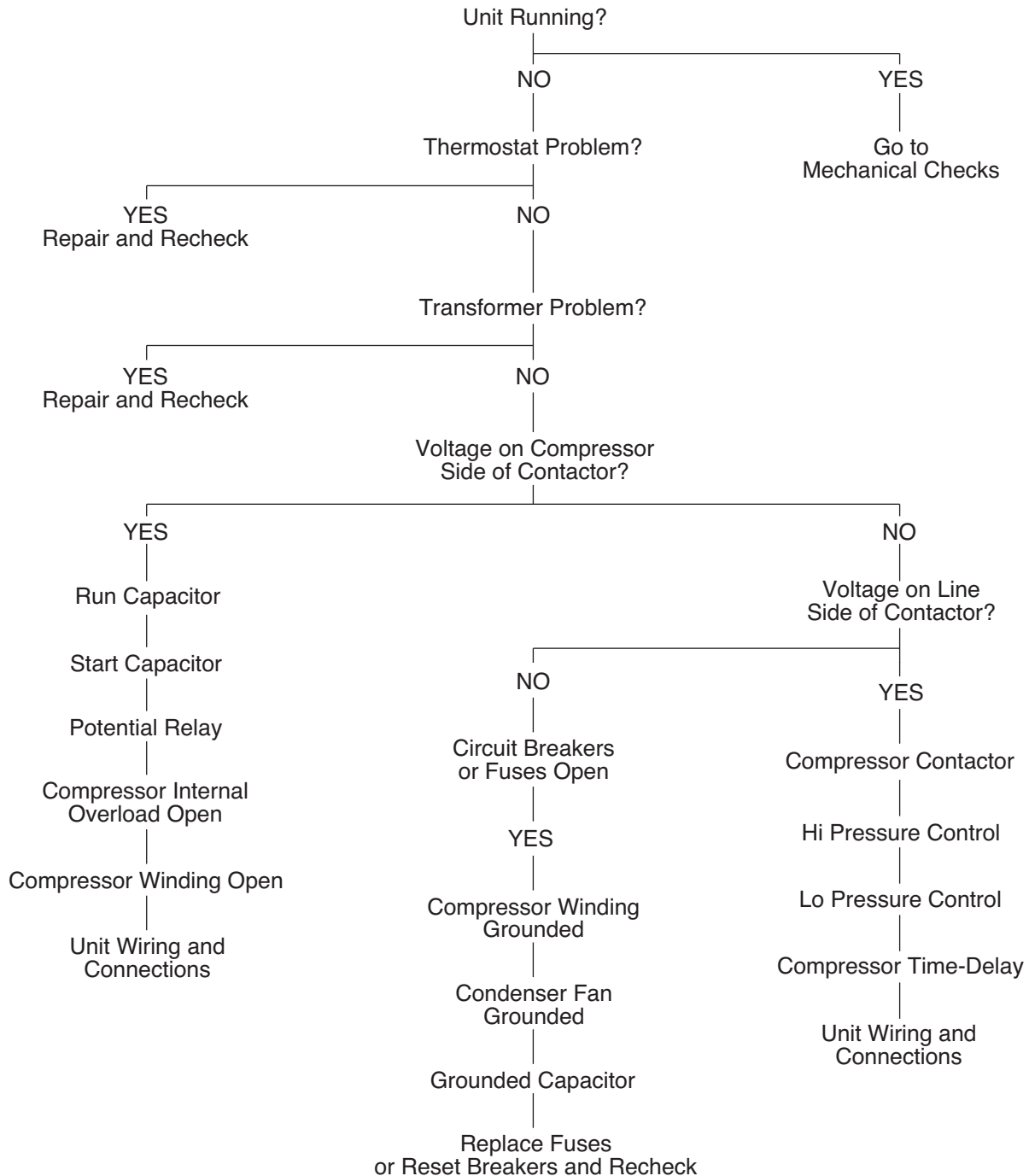

## 16.2 MECHANICAL CHECKS FLOW CHART

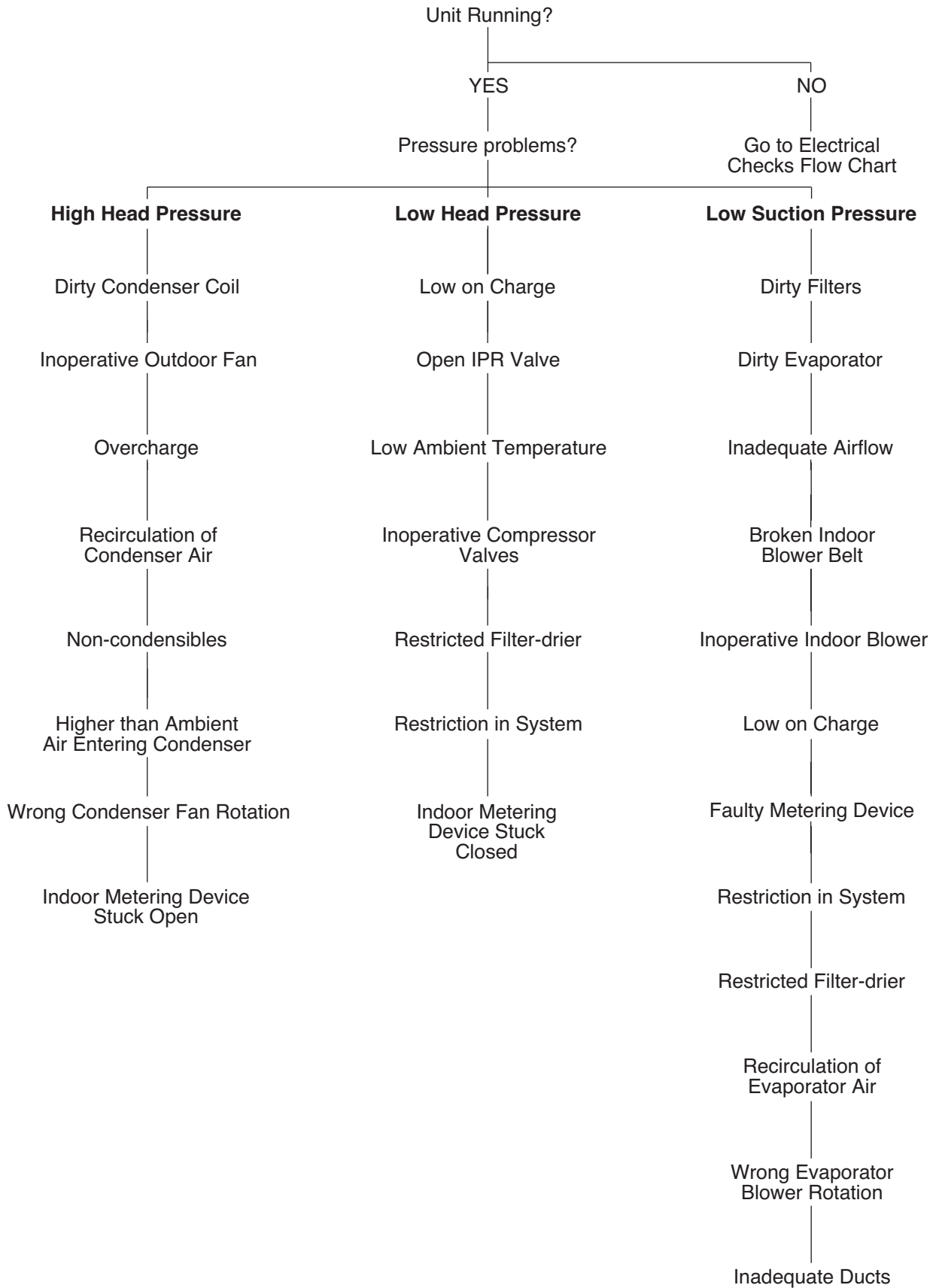

**TABLE 7**  
TEMPERATURE PRESSURE CHART

TEMP (Deg. F)	R-410A PSIG
-150	—
-140	—
-130	—
-120	—
-110	—
-100	—
-90	—
-80	—
-70	—
-60	0.4
-50	5.1
-40	10.9
-35	14.2
-30	17.9
-25	22.0
-20	26.4
-15	31.3
-10	36.5
-5	42.2
0	48.4
5	55.1
10	62.4
15	70.2
20	78.5
25	87.5
30	97.2
35	107.5
40	118.5
45	130.2
50	142.7
55	156.0
60	170.1
65	185.1
70	201.0
75	217.8
80	235.6
85	254.5
90	274.3
95	295.3
100	317.4
105	340.6
110	365.1
115	390.9
120	418.0
125	446.5
130	476.5
135	508.0
140	541.2
145	576.0
150	612.8

### 16.3 SUPERHEAT CALCULATION

1. Measure the suction pressure at the suction line service valve.
2. Convert the suction pressure to saturated temperature. See Table 8.
3. Measure the temperature of the suction line at the suction line service valve.
4. Compare the temperature of the suction line to the saturated temperature.
5. The difference between saturated temperature and suction line temperature is the superheat. Superheat normal range 12° to 15°.

### 16.4 SUBCOOLING CALCULATION

1. Measure the liquid pressure at the liquid line service valve.
2. Convert the liquid line pressure to saturated temperature. See Table 8.
3. Measure the liquid line temperature at the liquid line service valve.
4. Compare the liquid line temperature to the saturated temperature.
5. The difference between saturated temperature and liquid line temperature is the subcooling. Subcooling normal range 9° to 12°.

**TABLE 8**  
AIR CONDITIONING SYSTEM TROUBLESHOOTING TIPS

AIR CONDITIONING SYSTEM TROUBLESHOOTING TIPS					
SYSTEM PROBLEM	INDICATORS				
	DISCHARGE PRESSURE	SUCTION PRESSURE	SUPERHEAT	SUBCOOLING	COMPRESSOR AMPS
Overcharge	High	High	Low	High	High
Undercharge	Low	Low	High	Low	Low
Liquid Restriction (Drier)	Low	Low	High	High	Low
Low Evaporator Airflow	Low	Low	Low	Low	Low
Dirty Condenser	High	High	Low	Low	High
Low Outside Ambient Temperature	Low	Low	High	High	Low
Inefficient Compressor	Low	High	High	High	Low
TXV Feeler Bulb Charge Lost	Low	Low	High	High	Low
Poorly Insulated Sensing Bulb	High	High	Low	Low	High

## TROUBLE SHOOTING CHART

**▲ WARNING**

**DISCONNECT ALL POWER TO UNIT BEFORE SERVICING. CONTACTOR MAY BREAK ONLY ONE SIDE. FAILURE TO SHUT OFF POWER CAN CAUSE ELECTRICAL SHOCK RESULTING IN PERSONAL INJURY OR DEATH.**

SYMPTOM	POSSIBLE CAUSE	REMEDY
Unit will not run	<ul style="list-style-type: none"> <li>• Power off or loose electrical connection</li> <li>• Thermostat out of calibration-set too high</li> <li>• Defective contactor</li> <li>• Blown fuses / tripped breaker</li> <li>• Transformer defective</li> <li>• High pressure control open (if provided)</li> </ul>	<ul style="list-style-type: none"> <li>• Check for correct voltage at contactor in condensing unit</li> <li>• Reset</li> <li>• Check for 24 volts at contactor coil - replace if contacts are open</li> <li>• Replace fuses / reset breaker</li> <li>• Check wiring-replace transformer</li> <li>• Reset-also see high head pressure remedy-The high pressure control opens at 450 PSIG</li> </ul>
Outdoor fan runs, compressor doesn't	<ul style="list-style-type: none"> <li>• Run or start capacitor defective</li> <li>• Start relay defective</li> <li>• Loose connection</li> <li>• Compressor stuck, grounded or open motor winding, open internal overload.</li> <li>• Low voltage condition</li> </ul>	<ul style="list-style-type: none"> <li>• Replace</li> <li>• Replace</li> <li>• Check for correct voltage at compressor - check &amp; tighten all connections</li> <li>• Wait at least 2 hours for overload to reset. If still open, replace the compressor.</li> <li>• Add start kit components</li> </ul>
Insufficient cooling	<ul style="list-style-type: none"> <li>• Improperly sized unit</li> <li>• Improper indoor airflow</li> <li>• Incorrect refrigerant charge</li> <li>• Air, non-condensibles or moisture in system</li> </ul>	<ul style="list-style-type: none"> <li>• Recalculate load</li> <li>• Check - should be approximately 400 CFM per ton.</li> <li>• Charge per procedure attached to unit service panel</li> <li>• Recover refrigerant, evacuate &amp; recharge, add filter drier</li> </ul>
Compressor short cycles	<ul style="list-style-type: none"> <li>• Incorrect voltage</li> <li>• Defective overload protector</li> <li>• Refrigerant undercharge</li> </ul>	<ul style="list-style-type: none"> <li>• At compressor terminals, voltage must be ± 10% of nameplate marking when unit is operating.</li> <li>• Replace - check for correct voltage</li> <li>• Add refrigerant</li> </ul>
Registers sweat	<ul style="list-style-type: none"> <li>• Low indoor airflow</li> </ul>	<ul style="list-style-type: none"> <li>• Increase speed of blower or reduce restriction - replace air filter</li> </ul>
High head-low vapor pressures	<ul style="list-style-type: none"> <li>• Restriction in liquid line, expansion device or filter drier</li> <li>• Flowcheck piston size too small</li> <li>• Incorrect capillary tubes</li> </ul>	<ul style="list-style-type: none"> <li>• Remove or replace defective component</li> <li>• Change to correct size piston</li> <li>• Change coil assembly</li> </ul>
High head-high or normal vapor pressure - Cooling mode	<ul style="list-style-type: none"> <li>• Dirty outdoor coil</li> <li>• Refrigerant overcharge</li> <li>• Outdoor fan not running</li> <li>• Air or non-condensibles in system</li> </ul>	<ul style="list-style-type: none"> <li>• Clean coil</li> <li>• Correct system charge</li> <li>• Repair or replace</li> <li>• Recover refrigerant, evacuate &amp; recharge</li> </ul>
Low head-high vapor pressures	<ul style="list-style-type: none"> <li>• Flowcheck piston size too large</li> <li>• Defective Compressor valves</li> <li>• Incorrect capillary tubes</li> </ul>	<ul style="list-style-type: none"> <li>• Change to correct size piston</li> <li>• Replace compressor</li> <li>• Replace coil assembly</li> </ul>
Low vapor - cool compressor - iced indoor coil	<ul style="list-style-type: none"> <li>• Low indoor airflow</li> <li>• Operating below 65°F outdoors</li> <li>• Moisture in system</li> </ul>	<ul style="list-style-type: none"> <li>• Increase speed of blower or reduce restriction - replace air filter</li> <li>• Add Low Ambient Kit</li> <li>• Recover refrigerant - evacuate &amp; recharge - add filter drier</li> </ul>
High vapor pressure	<ul style="list-style-type: none"> <li>• Excessive load</li> <li>• Defective compressor</li> </ul>	<ul style="list-style-type: none"> <li>• Recheck load calculation</li> <li>• Replace</li> </ul>
Fluctuating head & vapor pressures	<ul style="list-style-type: none"> <li>• TXV hunting</li> <li>• Air or non-condensibles in system</li> </ul>	<ul style="list-style-type: none"> <li>• Check TXV bulb clamp - check air distribution on coil - replace TXV</li> <li>• Recover refrigerant, evacuate &amp; recharge</li> </ul>
Gurgle or pulsing noise at expansion device or liquid line	<ul style="list-style-type: none"> <li>• Air or non-condensibles in system</li> </ul>	<ul style="list-style-type: none"> <li>• Recover refrigerant, evacuate &amp; recharge</li> </ul>

# 17.0 WIRING DIAGRAMS

**FIGURE 3**  
**16.1 PSC OD FAN MOTOR**  
**SINGLE-PHASE WIRING DIAGRAM**

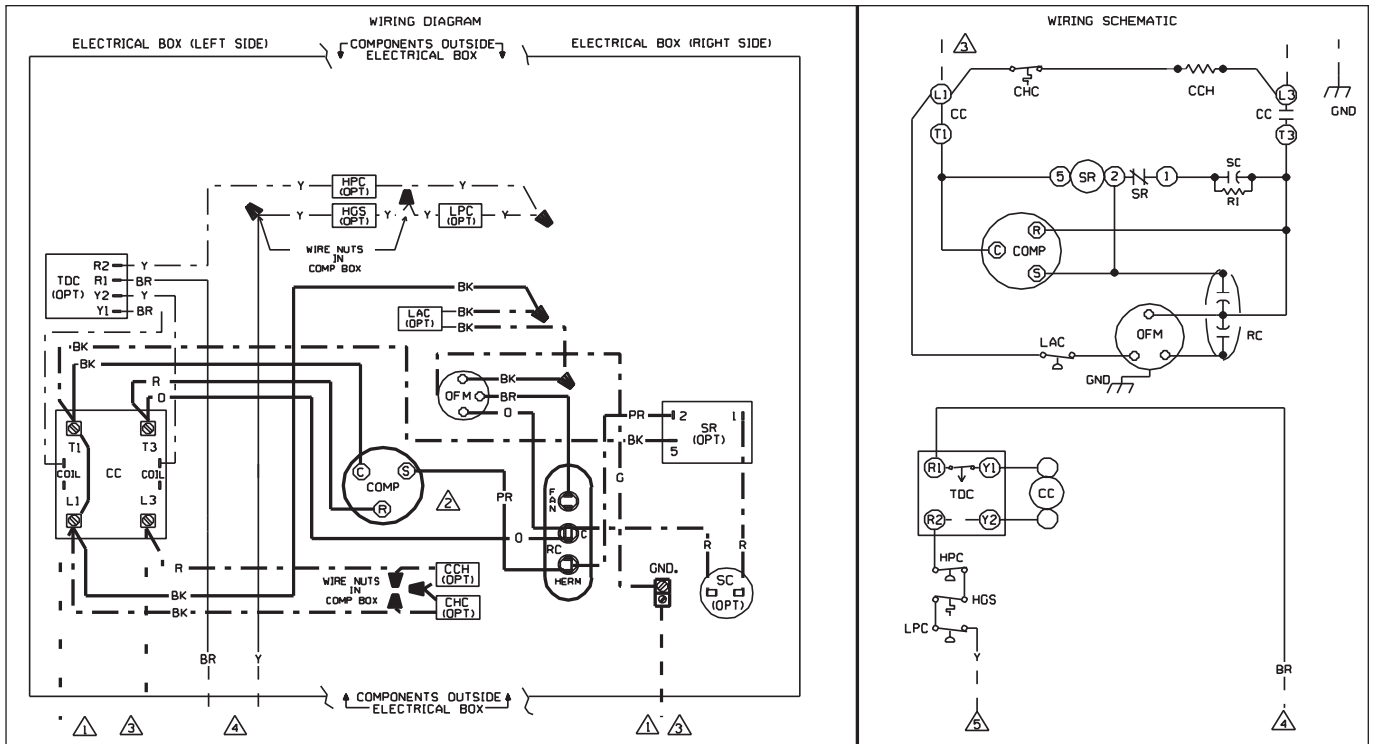

<p><b>COMPONENT CODE</b></p> <p>CC COMPRESSOR CONTACTOR          CCH CRANKCASE HEATER          CHC CRANKCASE HEATER CONTROL          COMP COMPRESSOR          GND GROUND, CHASSIS          HPC HIGH PRESSURE CUT-OUT CONTROL          LAC LOW AMBIENT COOLING CONTROL          LPC LOW PRESSURE CUT-OUT CONTROL          OFM OUTDOOR FAN MOTOR          OPT OPTIONAL          RC RUN CAPACITOR          SC START CAPACITOR          SR START RELAY          TDC TIME DELAY CONTROL          HGS HOT GAS SENSOR          PTCR POSITIVE TEMPERATURE COEFFICIENT RELAY</p>	<p><b>NOTES:</b> ⚠</p> <ol style="list-style-type: none"> <li>CONNECTORS SUITABLE FOR USE WITH COPPER CONDUCTORS ONLY.</li> <li>MOTOR COMPRESSOR THERMALLY PROTECTED AND ALL 3 PHASE ARE PROTECTED UNDER PRIMARY SINGLE PHASE CONDITIONS.</li> <li>CONNECT FIELD WIRING IN GROUNDED RAINTIGHT CONDUIT TO 60 HERTZ DISCONNECT, VOLTAGE AND PHASE PER RATING PLATE. USE 60° C WIRE.</li> <li>LOW VOLTAGE CIRCUIT TO BE N.E.C. CLASS 2 WITH A CLASS 2 TRANSFORMER 24 VOLT, 60 HERTZ.</li> <li>TO THERMOSTAT SUB-BASE, REFER TO SYSTEM SCHEMATICS OR SCHEMATICS ON INDOOR SECTION FOR LOW VOLTAGE CONTROL WIRING.</li> </ol>														
<p><b>WIRING INFORMATION</b></p> <p>LINE VOLTAGE          -FACTORY STANDARD      ————          -FACTORY OPTION        - - - -          -FIELD INSTALLED        - - - -</p> <p>LOW VOLTAGE          -FACTORY STANDARD      ————          -FACTORY OPTION        - - - -          -FIELD INSTALLED        - - - -</p> <p>REPLACEMENT WIRE          -MUST BE THE SAME SIZE AND TYPE OF INSULATION AS ORIGINAL (105° C MIN.)</p> <p><b>WARNING</b>          -CABINET MUST BE PERMANENTLY GROUNDED AND CONFORM TO I.E.C., N.E.C., C.E.C. AND LOCAL CODES AS APPLICABLE.</p>	<p><b>WIRE COLOR CODE</b></p> <table border="0"> <tr> <td>BK__BLACK</td> <td>O__ORANGE</td> </tr> <tr> <td>BR__BROWN</td> <td>PR__PURPLE</td> </tr> <tr> <td>BL__BLUE</td> <td>R__RED</td> </tr> <tr> <td>G__GREEN</td> <td>W__WHITE</td> </tr> <tr> <td>GY__GRAY</td> <td>Y__YELLOW</td> </tr> </table> <p style="text-align: center;"><b>WIRING DIAGRAM</b>          REMOTE AIR CONDITIONER          208/230 VOLT SINGLE PHASE</p>  <table border="1" style="width: 100%; border-collapse: collapse;"> <tr> <td style="width: 25%;">DR. BY JHB</td> <td style="width: 25%;">DATE 01-19-04</td> <td style="width: 25%;">DWG. NO. 90-101229-01</td> <td style="width: 25%;">REV 04</td> </tr> </table>	BK__BLACK	O__ORANGE	BR__BROWN	PR__PURPLE	BL__BLUE	R__RED	G__GREEN	W__WHITE	GY__GRAY	Y__YELLOW	DR. BY JHB	DATE 01-19-04	DWG. NO. 90-101229-01	REV 04
BK__BLACK	O__ORANGE														
BR__BROWN	PR__PURPLE														
BL__BLUE	R__RED														
G__GREEN	W__WHITE														
GY__GRAY	Y__YELLOW														
DR. BY JHB	DATE 01-19-04	DWG. NO. 90-101229-01	REV 04												

**FIGURE 4**  
16.2 ECM OD FAN MOTOR

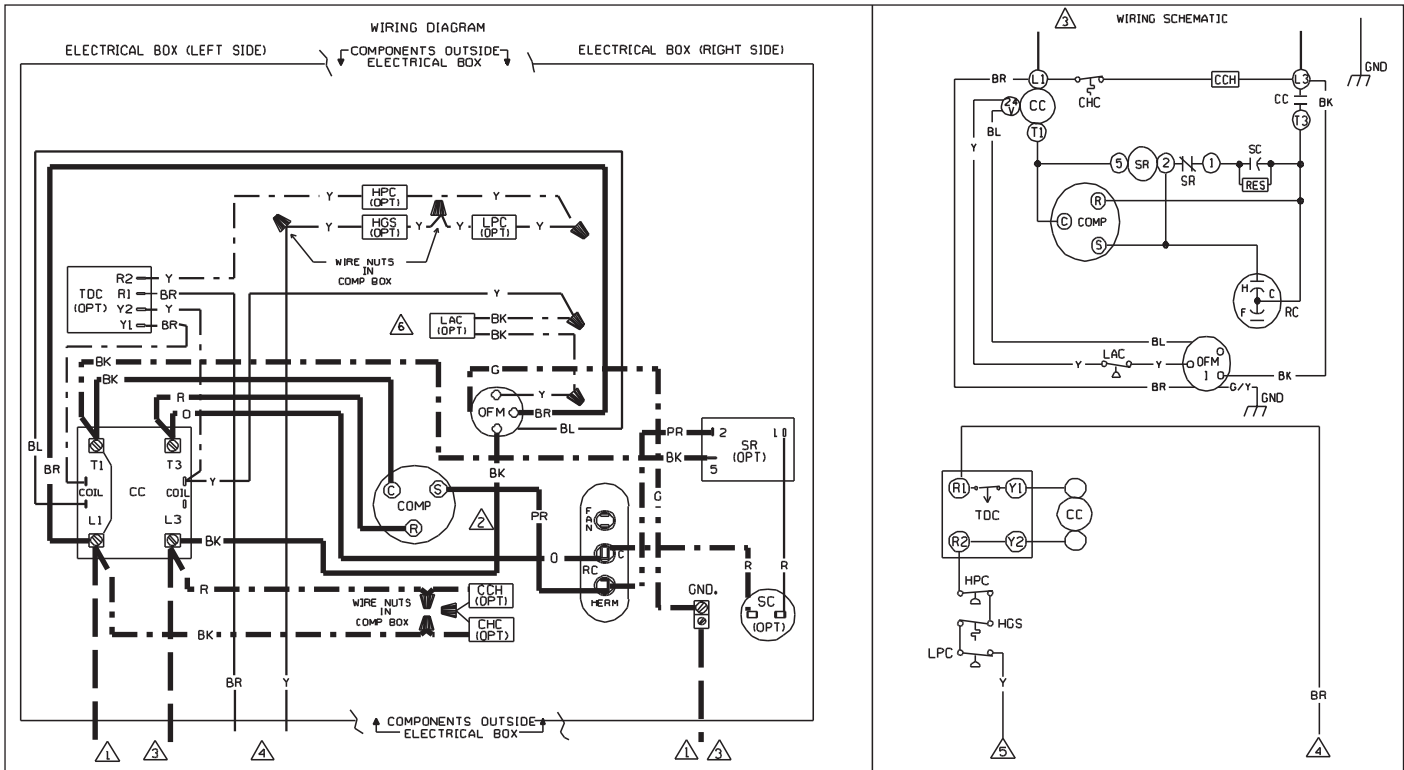

COMPONENT CODE		NOTES: ⚠	
CC	COMPRESSOR CONTACTOR	1.	CONNECTORS SUITABLE FOR USE WITH COPPER CONDUCTORS ONLY.
CCH	CRANKCASE HEATER	2.	MOTOR COMPRESSOR THERMALLY PROTECTED AND ALL 3 PHASE ARE PROTECTED UNDER PRIMARY SINGLE PHASE CONDITIONS.
CHC	CRANKCASE HEATER CONTROL	3.	CONNECT FIELD WIRING IN GROUNDED RAINTIGHT CONDUIT TO 60 HERTZ DISCONNECT, VOLTAGE AND PHASE PER RATING PLATE. USE 60° C WIRE.
COMP	COMPRESSOR	4.	LOW VOLTAGE CIRCUIT TO BE N.E.C. CLASS 2 WITH A CLASS 2 TRANSFORMER 24 VOLT, 60 HERTZ.
GND	GROUND, CHASSIS	5.	TO THERMOSTAT SUB-BASE, REFER TO SYSTEM SCHEMATICS OR SCHEMATICS ON INDOOR SECTION FOR LOW VOLTAGE CONTROL WIRING.
HPC	HIGH PRESSURE CUT-OUT CONTROL	6.	IF LAC/LAR IS NOT USED, CONNECT YELLOW WIRE FROM OFM TO 24V CC.
LAC	LOW AMBIENT COOLING CONTROL		
LPC	LOW PRESSURE CUT-OUT CONTROL		
OFM	OUTDOOR FAN MOTOR		
OPT	OPTIONAL		
RC	RUN CAPACITOR		
SC	START CAPACITOR		
SR	START RELAY		
TDC	TIME DELAY CONTROL		
HGS	HOT GAS SENSOR		
PTCR	POSITIVE TEMPERATURE COEFFICIENT RELAY		

  

WIRING INFORMATION		WIRE COLOR CODE	
LINE VOLTAGE		BK__BLACK	O___ORANGE
-FACTORY STANDARD	=====	BR__BROWN	PR__PURPLE
-FACTORY OPTION	-----	BL__BLUE	R___RED
-FIELD INSTALLED	-----	C___GREEN	W___WHITE
LOW VOLTAGE		GY__GRAY	Y___YELLOW
-FACTORY STANDARD	=====		
-FACTORY OPTION	-----		
-FIELD INSTALLED	-----		
REPLACEMENT WIRE			
-MUST BE THE SAME SIZE AND TYPE OF INSULATION AS ORIGINAL (105° C MIN.)			
WARNING			
-CABINET MUST BE PERMANENTLY GROUNDED AND CONFORM TO I.E.C., N.E.C., C.E.C. AND LOCAL CODES AS APPLICABLE.			

WIRING DIAGRAM REMOTE AIR CONDITIONER WITH OUTDOOR ECM MOTOR 208/230 VOLT SINGLE PHASE			
DR. BY	DATE	DWG. NO.	REV
MGR	10-8-08	90-101229-21	03

**FIGURE 5**  
**16.3 PSC OD FAN MOTOR**  
**THREE-PHASE WIRING DIAGRAM**

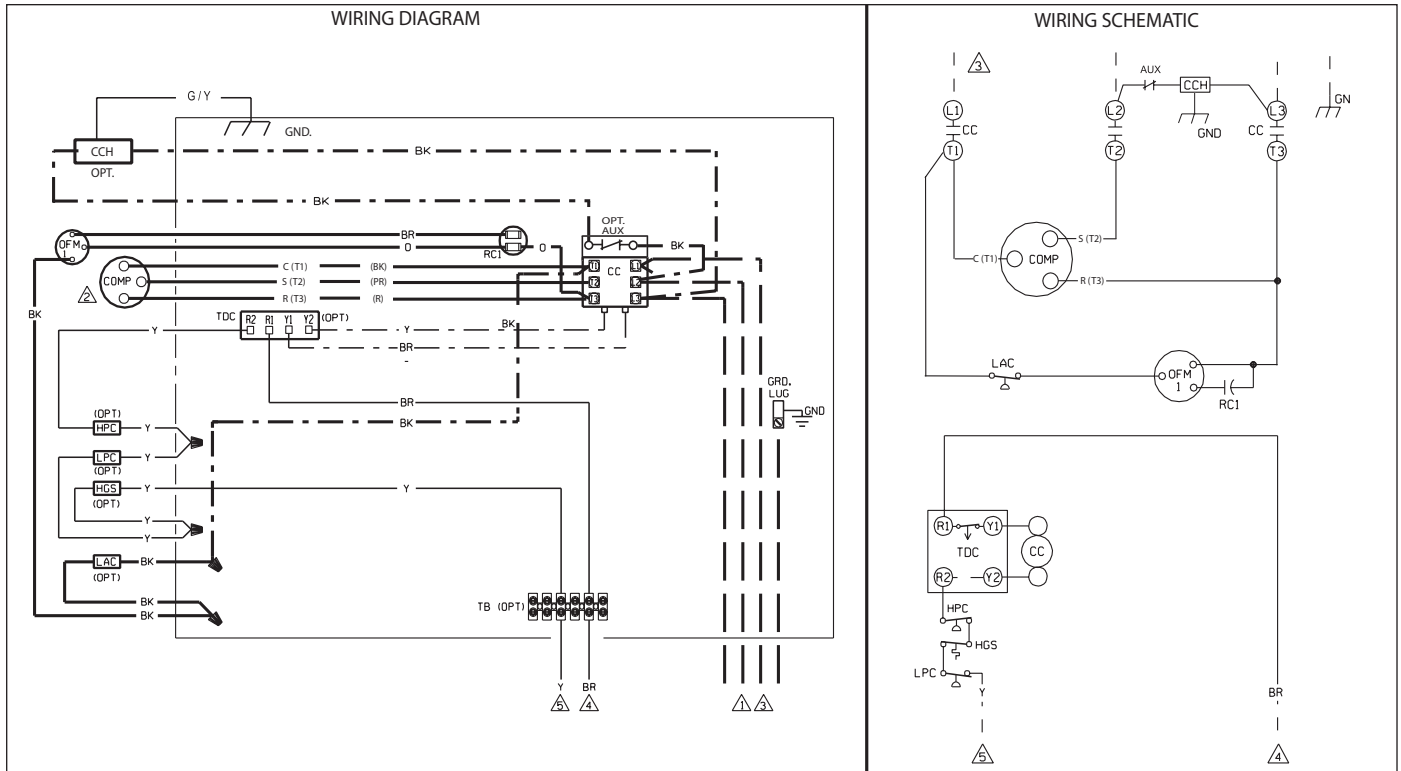

<p align="center"><b>COMPONENT CODE</b></p> <p>CC COMPRESSOR CONTACTOR          CCH CRANKCASE HEATER          COMP COMPRESSOR          GND GROUND, CHASSIS          HGS HOT GAS SENSOR          HPC HIGH PRES. CUT-OUT CONTROL          LAC LOW AMBIENT COOLING CONTROL          LPC LOW PRESSURE CONTROL          OFM OUTDOOR FAN MOTOR          OPT OPTIONAL          RC RUN CAPACITOR          RES RESISTOR          SC START CAPACITOR          SR START RELAY          TB TERMINAL BLOCK          TDC TIME DELAY CONTROL</p>	<p align="center"><b>NOTES:</b></p> <ol style="list-style-type: none"> <li>1. CONNECTORS SUITABLE FOR USE WITH COPPER CONDUCTORS ONLY.</li> <li>2. COMPRESSOR MOTOR THERMALLY PROTECTED AND ALL 3 PHASE ARE PROTECTED UNDER PRIMARY SINGLE PHASE CONDITIONS.</li> <li>3. CONNECT FIELD WIRING IN GROUNDED RAINLIGHT CONDUIT TO FUSED DISCONNECT, VOLTAGE, HERTZ AND PHASE PER RATING PLATE.</li> <li>4. LOW VOLTAGE CIRCUIT TO BE N.E.C. CLASS 2 WITH A CLASS 2 TRANSFORMER 24 VOLT, 50 OR 60 HERTZ.</li> <li>5. TO THERMOSTAT SUB-BASE, REFER TO SYSTEM SCHEMATICS OR SCHEMATICS ON INDOOR SECTION FOR LOW VOLTAGE CONTROL WIRING.</li> </ol>																			
<p align="center"><b>WIRING INFORMATION</b></p> <p>LINE VOLTAGE          -FACTORY STANDARD      ————          -FACTORY OPTION        - - - -          -FIELD INSTALLED        - - - -</p> <p>LOW VOLTAGE          -FACTORY STANDARD      ————          -FACTORY OPTION        - - - -          -FIELD INSTALLED        - - - -</p> <p>REPLACEMENT WIRE          -MUST BE THE SAME SIZE AND TYPE OF INSULATION AS ORIGINAL (105° C MIN.)</p> <p><b>WARNING</b>          -CABINET MUST BE PERMANENTLY GROUNDED AND CONFORM TO I.E.C., N.E.C., C.E.C. AND LOCAL CODES AS APPLICABLE.</p>	<p align="center"><b>WIRE COLOR CODE</b></p> <table style="width: 100%; border: none;"> <tr> <td>BK__BLACK</td> <td>O__ORANGE</td> </tr> <tr> <td>BR__BROWN</td> <td>PR__PURPLE</td> </tr> <tr> <td>BL__BLUE</td> <td>R__RED</td> </tr> <tr> <td>G__GREEN</td> <td>W__WHITE</td> </tr> <tr> <td>GY__GRAY</td> <td>Y__YELLOW</td> </tr> </table> <p align="center" style="font-size: 1.2em; margin-top: 20px;"><b>ELECTRICAL WIRING DIAGRAM</b></p> <p align="center" style="font-size: 1.2em; margin-top: 10px;"><b>REMOTE AIR CONDITIONER THREE PHASE</b></p> <div style="text-align: right; margin-top: 10px;"> </div> <table border="1" style="width: 100%; border-collapse: collapse; margin-top: 10px;"> <tr> <td style="width: 15%;">DR. BY</td> <td style="width: 15%;">JHB</td> <td style="width: 15%;">APP. BY</td> <td style="width: 15%;">DATE</td> <td style="width: 15%;">6-01-07</td> <td style="width: 15%;">DWG. NO.</td> <td style="width: 15%;">90-101229-11</td> <td style="width: 10%;">REV</td> <td style="width: 10%;">07</td> </tr> </table>	BK__BLACK	O__ORANGE	BR__BROWN	PR__PURPLE	BL__BLUE	R__RED	G__GREEN	W__WHITE	GY__GRAY	Y__YELLOW	DR. BY	JHB	APP. BY	DATE	6-01-07	DWG. NO.	90-101229-11	REV	07
BK__BLACK	O__ORANGE																			
BR__BROWN	PR__PURPLE																			
BL__BLUE	R__RED																			
G__GREEN	W__WHITE																			
GY__GRAY	Y__YELLOW																			
DR. BY	JHB	APP. BY	DATE	6-01-07	DWG. NO.	90-101229-11	REV	07												

